

# İçindekiler

## Index

### Inhaltsverzeichnis



<b>Genel Bilgiler</b> General Info. Einführung	<b>Sembollerin Açıklaması</b>	<i>Key of Symbols</i>	Erklärung der Bezeichnungen	03
	<b>Ürün Yelpazesi</b>	<i>Production Range</i>	Produktpalette	04
	<b>D Serisi Redüktörlerin Genel Özellikleri</b>	<i>General Specifications of D Series Gearboxes</i>	Allgemeine Eigenschaften Von D Serie Getrieben	06
	<b>Teknik Tanımlamalar</b>	<i>Technical Explanations</i>	Technische Erläuterungen	07
	<b>Teknik Özellikler</b>	<i>Technical Specifications</i>	Technische Informationen	07
	<b>Aksesuarlar</b>	<i>Accessories</i>	Zubehör	08
	<b>Yüzey Koruması</b>	<i>Surface Protection</i>	Oberflächenschutz	10
	<b>Tip Tanımlaması</b>	<i>Unit Designation</i>	Typenbezeichnungen	10
	<b>Örnek Tip Tanımlamaları</b>	<i>Sample Designations</i>	Typenbezeichnungsbeispiele	13
	<b>Motor Büyüklüğüne Göre Geometrik Çevrim Oranı Komb.</b>	<i>Geomet. Possible Combinations of Ratios According to Motor Size</i>	Geomet. Mögliche Kombi. von Übersetz. nach Motorbaugröße	14
	<b>Servis Faktörü</b>	<i>Service Factor</i>	Betriebsfaktor	16
	<b>Yük Sınıflandırması</b>	<i>Load Classification</i>	Belastungsart	17
	<b>Redüktör Dönüş Yönleri</b>	<i>Direction of Rotation</i>	Getriebedrehrichtungen	19
	<b>Radyal Yükler</b>	<i>Overhung Loads</i>	Querkräfte	20
	<b>Radyal Yüklerin Hesabı</b>	<i>Calculation Of Overhung Loads</i>	Berechnung der Querkräfte	21
	<b>Ekstruder Tiplerde Müsade Edilebilir Eksenel Yükler</b>	<i>Permissible Axial Loads for Extruder Types</i>	Zulässige Axialkräfte für Extruder Typ Getrieben	22
	<b>Eşdeğer Güç Hesabı</b>	<i>Equivalent Power Calculation</i>	Äquivalente Leistung	24
	<b>Eşdeğer Güç Hesabı Örneği</b>	<i>Equivalent Power Cal. Example</i>	Beispiel für Äquivalente Leistung	25
	<b>Redüktör Seçimi</b>	<i>Gearbox Selection</i>	Getriebeauswahl	26
	<b>Redüktör Seçim Formu</b>	<i>Gearbox Selection Form</i>	Formular für Getriebeauswahl	28
	<b>Yağlama</b>	<i>Lubrication</i>	Schmierung	31
	<b>Genleşme Tankı</b>	<i>Expansion Tank</i>	Ölauseggsbehälter	32
	<b>Yağ Tipleri</b>	<i>Oil Types</i>	Schmierstoffe	33
	<b>Montaj Pozisyonları</b>	<i>Mounting Positions</i>	Bauformen	34
	<b>Montaj Şekilleri ve Yağ Tapaları</b>	<i>Mounting Pos. and Oil plugs</i>	Bauform. und Ölverschlussschra.	35
	<b>Yağ Miktarları</b>	<i>Oil Quantities</i>	Ölmengen Tabellen	35
<b>Motorlar</b> Motors Motoren	<b>AC Motorlar</b>	<i>AC Motors</i>	Drehstrommotoren:	
	<b>a- Genel Özellikler</b>	<i>a- General Spec. of AC Motors</i>	a-Eigensch. des Drehstrommotors	38
	<b>b- Çalışma Türleri</b>	<i>b-Modes of Operation</i>	b-Betriebsarten	39
	<b>c- Koruma Sınıfı</b>	<i>c- Protection Class</i>	c- Schutzarten	40
	<b>d- İzolasyon Sınıfı</b>	<i>d- Insulation Class</i>	d- Isolationsklasse	40

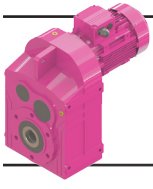

# İçindekiler

## Index

### Inhaltsverzeichnis



	<b>e- Verim Sınıfları</b>	<i>e- Efficiency Classes</i>	e- Energieeffizienzklassen	40
<b>Motorlar</b> <i>Motors</i> Motoren	<b>f- AC Frekans İvertörler</b>	<i>f- AC Frequency Inverters</i>	f- AC Frequenz Umrichter	41
	<b>DC Motorlar</b>	<i>DC Motors</i>	DC Motoren	
	<b>a- Genel Özellikler</b>	<i>a- General Specif. of DC Motors</i>	a- Eigenschaften von DC Motoren	42
	<b>b- DC Motorların Çalışma İlkeleri</b>	<i>b- Operating principals of DC Motors</i>	b- Funktionsprinzip der DC Motoren	42
	<b>c- DC Motor Çeşitleri</b>	<i>c- Types of DC Motors</i>	c- Arten von DC Motoren	42
	<b>d- DC Motorlarda Hız Kontr.</b>	<i>d- Speed Control of DC motors</i>	d- Drehzahl Kontrolle DC Motoren	42
<b>Frenler</b> <i>Brakes</i> Bremsen	<b>Elektromanyetik Frenler</b>	<i>Electromagnetic Brakes</i>	Elektromagnetische Bremsen	43
	<b>Fren Çeşitleri</b>	<i>Brake Types</i>	Bremsenarten	43
	<b>Fren Bağlantı Şekli</b>	<i>Connection Types</i>	Schaltungsarten	44
	<b>Fren Seçimi</b>	<i>Brake Selection</i>	Bremswahl	45
	<b>Frenin Termik Kapasitesi</b>	<i>The Thermal Capacity of Brake</i>	Therm. Kapazität der Bremsen	46
<b>Güç Devir Tabl.</b> <i>Perform. Tables</i> Leistungs und Drehzahl tabellen	<b>Motorlu Güç Devir Tabloları</b>	<i>Geared Motors Performance Tables</i>	Getriebe motoren Leistung und drehzahl Übersicht	47
	<b>Motorsuz Güç Devir Tabloları</b>	<i>Gear Units Performance Tables</i>	Getriebe Leistung und Drehzahl-übersicht	251
<b>Ölçü Sayfaları</b> <i>Dimension Pages</i> Abmesungstabel- len	<b>DR serileri</b>	<i>DR series</i>	DR serie	93
	<b>DN serileri</b>	<i>DN series</i>	DN serie	146
	<b>DV serileri</b>	<i>DV series</i>	DV serie	198
	<b>DT serileri</b>	<i>DT series</i>	DT serie	263
<b>Mil ve Kovan Ölçüleri</b> <i>Shaft and Hollow Shaft Dimensions</i> Wellen und Gehäusemaße	<b>DE Ekstruder Boğazlı Redüktörler</b>	<i>DE Extruder Type Gearboxes</i>	DE Extruder Getriebe von D Serie	316
	<b>Sıkma Bilezikli Redüktörler</b>	<i>Gearboxes with Shrink Disk Connector</i>	D Serie Hohwelle mit Schrumpfscheibe	321
	<b>D serisi Kovan Ölçüleri</b>	<i>D series Hollow Shaft Dimensions</i>	Gehäuseabmessungen von D Serie Getriebe	322
	<b>Moment Kollu Redüktörler</b>	<i>Gearboxes with Torque Arm</i>	Drehmomentstütze Montagezeichnungen	322
	<b>Delik Milli Redüktörler için Montaj Önerileri</b>	<i>Mounting Advices for Hollow Shaft Gearboxes</i>	Montagevorschläge Für D Serie Getriebe	323
	<b>Moment Kolu Bağlantı Ölçüleri</b>	<i>Torque Arm Mounting Dimensions</i>	Montageabmessungen von Drehmomentstütze	324
	<b>DIN 5480 Çoklu Kama Ölçüleri</b>	<i>Dimensions of Splined Hollow Shaft to DIN 5480</i>	Abmessungen von Hohlwelle mit Vielkeilverzahnung nach DIN 5408	325
<b>Karıştırıcı Redüktörleri</b> <i>Drywell Gearboxes</i> Drywell Getriebe	<b>Karıştırıcı Redüktörleri Ölçüleri</b>	<i>Drywell Gearboxes Dimensions</i>	Drywell Getriebe Abmessungen	326
	<b>Opsiyonel Çıkış Flanş Ölçüleri</b>	<i>Optional Output Flange Dimensions</i>	Auswählbare Abtriebsflanschdimensionen	329
<b>Motorlar</b> <i>Motors</i> Motoren	<b>Elektrik Motorlarının Performans Değerleri</b>	<i>Electric Motors Ratings and Performance</i>	Elektromotoren Leistungsdaten	331

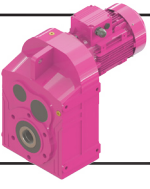

# Genel Bilgiler

## General Information

### Einführung



#### Sembollerin Açıklaması

$c_t$ .....: Anahtarın devreye girme zamanı katsayısı

$f_s$ .....: Servis faktörü

$F_{ama}$ .....: Çıkış milinde müsaade edilen eksenel yükler [kN]

$F_{ame}$ .....: Giriş milinde müsaade edilen eksenel yükler [kN]

$F_{qam}$ .....: Çıkış milinde izin verilen radyal yükler [N]

$F_{qem}$ .....: Giriş milinde izin verilen radyal yükler [N]

$F_{qa}$ .....: Çıkış miline gelen radyal yükler [N]

$F_{qe}$ .....: Giriş miline gelen radyal yükler [N]

$F_q$ .....: Radyal yönde çıkış miline gelen yükler [N]

$F_a$ .....: Eksenel yönde çıkış miline gelen yükler [N]

$i$ .....: Tahvil oranı

$J_{ext}$ .....: Motor miline indirgenmiş toplam dış atalet momenti [kgm<sup>2</sup>]

$M_2$ .....: Çıkış momenti [Nm]

$M_a$ .....: Anma momenti [Nm]

$n_1$ .....: Redüktör giriş mili devri [d/dak]

$n_2$ .....: Redüktör çıkış mili devri [d/dak]

$P_{eq}$ .....: Eşdeğer güç [W]

$P_e$ .....: Nominal güç (Bak. Güç-Devir Tabloları) [W]

$P_M$ .....: Tahrik edilecek makina için gerekli güç (Değişken yükler için eşdeğer güç alınır) [kW]

$t$ .....: Zaman [s]

$T_e$ .....: Eşdeğer moment [Nm]

#### Key of Symbols

$c_t$ .....: Coefficient of switch on time.

$f_s$ .....: Service factor

$F_{ama}$ .....: Permissible axial loads which can be applied to output shafts [kN]

$F_{ame}$ .....: Permissible axial loads which can be applied to input shafts [kN]

$F_{qam}$ .....: Permissible overhung loads which can be applied to output shafts [N]

$F_{qem}$ .....: Permissible overhung loads which can be applied to input shafts [N]

$F_{qa}$ .....: Overhung loads applied to the output shaft [N]

$F_{qe}$ .....: Overhung loads applied to the input shafts [N]

$F_q$ .....: Overhung loads on output shaft [N]

$F_a$ .....: Axial loads on output shaft [N]

$i$ .....: Transmission ratio

$J_{ext}$ .....: The total inertia of rotating parts at outside reduced at the motor shaft [kgm<sup>2</sup>]

$M_2$ .....: Output torque [N]

$M_a$ .....: Nominal torque [Nm]

$n_1$ .....: Input speed of gearbox [rpm]

$n_2$ .....: Output speed of gearbox [rpm]

$P_{eq}$ .....: Equivalent power [W]

$P_e$ .....: Nominal power (given on performance tables) [W]

$P_M$ .....: Power consumption of the driven machine (for alternating power, refer to equivalent power) [kW]

$t$ .....: Time [s]

$T_e$ .....: Equivalent torque [Nm]

#### Erklärung der Bezeichnungen

$c_t$ .....: Koeffizient der Tätigkeitszeit von Schalter

$f_s$ .....: Betriebsfaktor

$F_{ama}$ .....: Zulässige Axialkräfte auf Abtriebswelle [kN]

$F_{ame}$ .....: Zulässige Axialkräfte auf Antriebswelle [kN]

$F_{qam}$ .....: Zulässige Querkräfte auf Abtriebswelle [N]

$F_{qem}$ .....: Zulässige Querkräfte auf Antriebswelle [N]

$F_{qa}$ .....: Querkräfte auf Abtriebswelle [N]

$F_{qe}$ .....: Querkräfte auf Antriebswelle [N]

$F_q$ .....: Querkräfte auf Abtriebswelle [N]

$F_a$ .....: Axialkräfte auf Abtriebswelle [N]

$i$ .....: Übersetzungsverhältnis

$J_{ext}$ .....: Die Gesamtträgheit der rotierende Teile von der Ausgangsseite reduziert auf Motorwelle [kgm<sup>2</sup>]

$M_2$ .....: Ausgangsdrehmoment [N]

$M_a$ .....: Nenndrehmoment [Nm]

$n_1$ .....: Antriebsdrehzahl [U/min]

$n_2$ .....: Abtriebsdrehzahl [U/min]

$P_{eq}$ .....: Äquivalente Leistung [W]

$P_e$ .....: Getriebe Nennleistung (siehe Leistung- Drehzahl Tabellen) [W]

$P_M$ .....: Leistung benötigt an der Abtriebswelle (Zur Berechnung bei variabler Leistungen äquivalente Leistung benutzen) [kW]

$t$ .....: Zeit [s]

$T_e$ .....: Äquivalentes Drehmoment [Nm]

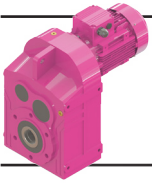

# Genel Bilgiler

## General Information

### Einführung



#### Ürün Yelpazesi

Elinizdeki katalog sadece **D serisi** ürünleri içermektedir.

##### - M ve N Serisi

Helisel alın dişliye sahip, giriş ve çıkış milleri aynı düzlem üzerinde ve birbirine paralel uzanan, üzerlerinde bulunan ayak veya flanş ile makina-ya sabitlenen redüktörlerdir. Dolu mil çıkışlıdır.

##### - D Serisi

Helisel alın dişliye sahip, giriş ve çıkış milleri aynı düzlem üzerinde, birbirine paralel ve belirli bir aralıkta yerleştirilmiş, iki yan yüzde bulunan bağlantı civataları, flanş veya tork kolu ile makina-ya sabitlenen redüktörlerdir. Delik milli veya mil çıkışlı olabilir.

##### - E Serisi

Sonsuz vida ve çark dişlili, belirli bir aralıkta ve birbirine dik konumlandırılmış giriş ve çıkış millerine sahip, çepçevre konumlandırılmış ayak bağlantıları, flanş veya tork kolu ile makina-ya sabitlenen redüktörlerdir. Delik milli veya mil çıkışlı olabilir.

##### - Y Serisi

Yatık tip redüktörler, ağır şartlarda çalışmak üzere dizayn edilmiş redüktör tipleridir. Bu tiplerde redüktör ile bunu tahrik eden mekanizma arasında değişik bağlantı şekilleri mevcuttur (Mekanik ve hidrolik kaplinler, çeşitli tip kayışlar ve zincirle tahrik gibi). Delik milli veya mil çıkışlı olabilir.

##### - K Serisi

Helisel alın dişli ve konik dişlilerden oluşan, birbirine dik ve belirli bir aralıkta konumlandırılmış giriş ve çıkış milline sahip, çepçevre sunulan ayaklar, flanş veya tork kolu ile makina-ya sabitlenen redüktörlerdir. E serisinden farklı olarak yüksek verime sahiptirler. Delik milli veya mil çıkışlı olabilir.

##### - H ve B Serisi

Helisel ve/veya konik dişliye sahip ağır hizmet tipi redüktörlerdir. Giriş ve çıkış milleri birbirine paralel veya dik olabilir. Her yönden bağlantı için ayak bağlantıları bulunur. Opsiyonel olarak flanş ile de bağlanabilir. Delik milli veya mil çıkışlı olabilir.

##### - T Serisi

T Serisi redüktörler helisel dişli iki kademe motorsuz delik milli redüktörlerdir. T Serisi redüktörler delik milli olması ve kompakt gövde yapısı sayesinde daha küçük hacimli alanlara montajı yapılabilmektedir.

##### - P ve R Serisi

P ve R Serisi redüktörler planet dişli redüktörlerdir. Endüstriyel ve mobil uygulamalarda kullanılırlar. Diğer redüktör tiplerine göre daha küçük hacimde daha büyük tork iletebilirler.

##### - VR Serisi

VR vinç redüktörleri M1 - M8 (1Dm - 5m) yük sınıflarına uygun olarak, çift veya sabit devirli frenli motorlarla üretilebilmektedir.

#### Production Range

*This catalogue is containing D series of gearboxes only.*

##### - M and N Series

*M and N series of YILMAZ REDÜKTÖR are helical geared. The input and output shafts are parallel to each other and on the same plane. The gearbox can be connected to the machine by using the foot or flange on the gearbox. Has solid output shaft.*

##### - D Series

*D series are helical geared gearboxes with parallel input and output shafts. The shafts have a distance in between and located on the same plane. The gearbox can be assembled to the machine by using the foot, the connection screws on the sides, flange or torque arm on the gearbox. Can have hollow or solid output shaft.*

##### - E Series

*E series gearboxes are with worm and worm-wheel. The input and output shafts are perpendicular to each other and have a distance in between. It can be assembled to the driven machine by the use of the foot, flange or torque arm on the gearbox. Can have hollow or solid output shaft.*

##### - Y Series

*Horizontal type gearboxes are designed to operate in heavy conditions. In these types there are a lot of combination forms between gearbox and driver (for example, mechanic and hydraulic couplings, various belt and chain drives etc.). Can have hollow or solid output shaft.*

##### - K Series

*These are gearboxes with helical and bevel gears. The input and output shafts are perpendicular to each other and have a distance in between. It can be assembled to the driven machine using the foot, flange or torque arm on the gearbox. They have high efficiency compared to E series. Can have hollow or solid output shaft.*

##### - H and B Series

*These gearboxes are helical or/and bevel geared industrial gearboxes. The input and output shafts can be arranged parallel or perpendicular to each other. The gearbox can be assembled by the use of the foot connections on each side. Flange connections are optional. Can have hollow or solid output shaft.*

##### - T Series

*T Series are gear units which are helical geared, two staged, hollow shaft mounted gear units and manufactured according to monoblock principal. T Series gearboxes have hollow shaft and compact housing so that T series can be mounted on smaller places.*

##### - P and R Series

*P and R Series gearboxes are planetary gearboxes. They are mostly used by industrial and mobile applications. Planetary gearboxes can transfer high torques in small volumes compared to other gearboxes.*

##### - VR Serie

*VR hoist drives are produced according to M1 - M8 (1Dm - 5m) load classification.*

#### Produktpalette

Dieses Katalog umfasst nur die **D Serien** Getriebe.

##### - M und N Serie

Diese Modelle sind Stirnradgetriebe mit parallelen Antriebs- und Abtriebswelle auf einer Ebene. Die Getriebe werden mit Fuß- oder Flanschverbindung an die angetriebene Maschine angekoppelt. Hat Vollwelle am Ausgang.

##### - D Serie

Diese Getriebe sind Stirnradgetriebe mit paralleler Antriebs- und Abtriebswelle, die auf einer Ebene liegen und einen Abstand zueinander haben. Diese Getriebe wird seitlich mit Gewindelöchern am Maschine oder mit einer Flansch verbindet. Kann Voll- und Hohlwelle am Ausgang haben.

##### - E Serie

Diese Getriebe bestehen aus Schnecke und Schneckenrad. Die Antriebs- und Abtriebswellen sind senkrecht zueinander und haben einen bestimmten Abstand. Das Getriebe wird mit Fußbefestigung, Flanschverbindung oder mit Drehmomentstütze an die angetriebene Maschine montiert. Kann Voll- und Hohlwelle am Ausgang haben.

##### - Y Serie

Diese Getrieben sind für Einsatz unter schweren Bedingungen ausgelegt. Bei dieser Ausführung gibt es sehr viele verschiedene Verbindungsmöglichkeiten zwischen Antrieb und Getriebe (Zum Beispiel; mechanische und hydraulische Kupplungen, Riemtrieb, Kettentrieb usw.). Kann Voll- und Hohlwelle am Ausgang haben.

##### - K Serie

Diese Getrieben bestehen aus Stirnräder und Kegelräder. Die Antrieb und Abtriebswellen sind senkrecht und haben einen Abstand zueinander. Das Getriebe wird mit Fußbefestigung, Flanschverbindung oder Drehmomentstütze an die angetriebene Maschine montiert. Der Wirkungsgrad ist wesentlich höher als E Serie. Kann Voll- und Hohlwelle am Ausgang haben.

##### - H und B Serie

Diese Getriebe sind geeignet für industrielle Anwendungen und haben parallelen oder senkrechten Antrieb und Abtriebswelle auf einer Ebene. Das Getriebe kann mit Füßen, die auf jede Seite der Getriebe vorhanden sind, oder optional mit Flansch an die angetriebene Maschine montiert werden. Kann Voll- und Hohlwelle am Ausgang haben.

##### - T Serie

TSerien Getriebe sind zwei stufige, schrägverzahnte Hohlwellenflachgetriebe in Monoblockgehäuse. Die T Serie hat eine kompakte Gehäuse und ist serienmäßig mit Abgangshohlwelle hergestellt, so dass das Getriebe minimalen Platzbedarf hat.

##### - P und R Serie

P und R Serie sind Planetengetriebe, die vielseitig im Industrie und bei mobiler Anwendungen einsetzbar sind, mit Planetenzahnräder. Planetengetriebe können im Vergleich zu anderen Getrieben größere Drehmomente bei kleineren Bauvolumen übertragen.

##### - VR Serie

VR Krane und Hebezeuge werden geeignet zur Belastungsart M1 - M8 (1Dm - 5m) hergestellt.

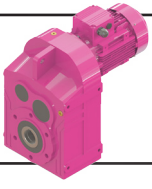

## Genel Bilgiler General Information Einführung

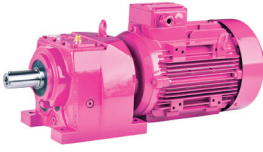

M ...

**13 farklı büyüklükte;**  
**Moment aralığı: 50 - 18.000 Nm**  
**Devir aralığı: 0,1 - 500 d/dak**  
13 different sizes:  
Torque range: 50 - 18.000 Nm  
Speed range: 0,1 - 500 rpm  
13 verschiedene Baugrößen:  
Drehmomentbereich: 50 - 18.000 Nm  
Drehzahlbereich : 0,1 - 500 U/min



N ...

**13 farklı büyüklükte;**  
**Moment aralığı: 50 - 18.000 Nm**  
**Devir aralığı: 0,1 - 500 d/dak**  
13 different sizes:  
Torque range: 50 - 18.000 Nm  
Speed range: 0,1 - 500 rpm  
13 verschiedene Baugrößen:  
Drehmomentbereich: 50 - 18.000 Nm  
Drehzahlbereich : 0,1 - 500 U/min

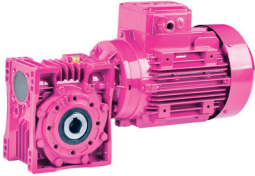

E ...

**8 farklı büyüklükte;**  
**Moment aralığı: 5 - 1.000 Nm**  
**Devir aralığı: 0,1 - 400 d/dak**  
8 different sizes:  
Torque range: 5 - 1.000 Nm  
Speed range: 0,1 - 400 rpm  
8 verschiedene Baugrößen:  
Drehmomentbereich: 5-1.000 Nm  
Drehzahlbereich : 0,1-400 U/min

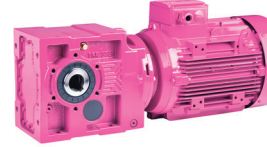

K ...

**13 farklı büyüklükte;**  
**Moment aralığı: 200 - 20.000 Nm**  
**Devir aralığı: 0,1 - 400 d/dak**  
13 different sizes:  
Torque range: 200 - 20.000 Nm  
Speed range: 0,1 - 400 rpm  
13 verschiedene Baugrößen:  
Drehmomentbereich: 200 - 20.000 Nm  
Drehzahlbereich : 0,1 - 400 U/min

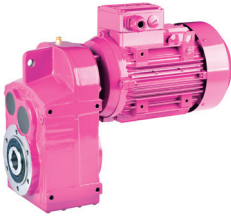

D ...

**11 farklı büyüklükte;**  
**Moment aralığı: 150 - 18.000 Nm**  
**Devir aralığı: 0,1 - 350 d/dak**  
11 different sizes:  
Torque range: 150 - 18.000 Nm  
Speed range: 0,1 - 350 rpm  
11 verschiedene Baugrößen:  
Drehmomentbereich: 150 - 18.000 Nm  
Drehzahlbereich : 0,1 - 350 U/min

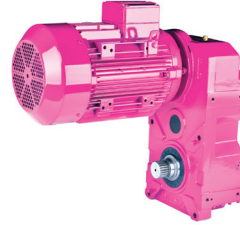

VR ...

**VR vinç redüktörleri**  
**M1 - M8 ,(1Dm - 5m) yük sınıfı**  
**ISO 4301 / 1 ,(FEM 1.001 / III)**  
VR Hoist Drive Units  
M1 - M8 ,(1Dm - 5m) load classification  
ISO 4301 / 1 ,(FEM 1.001 / III)  
VR Kran und Hebezeug Getriebe  
M1 - M8 ,(1Dm - 5m) Belastungsart  
ISO 4301 / 1 ,(FEM 1.001 / III)

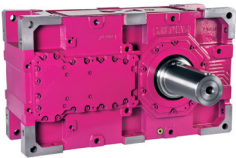

H ...

**20 farklı büyüklükte;**  
**Moment aralığı: 2.500 - 470.000 Nm**  
**Devir aralığı: 0,1 - 250 d/dak**  
20 different sizes:  
Torque range: 2.500 - 470.000 Nm  
Speed range: 0,1 - 250 rpm  
20 verschiedene Baugrößen:  
Drehmomentber. :2.500 - 470.000 Nm  
Drehzahlbereich : 0,1 - 250 U/min

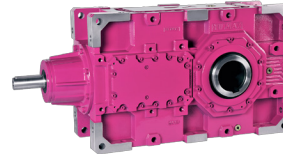

B ...

**20 farklı büyüklükte;**  
**Moment aralığı: 5.000 - 470.000 Nm**  
**Devir aralığı: 0,1 - 115 d/dak**  
20 different sizes:  
Torque range: 5.000 - 470.000 Nm  
Speed range: 0,1 - 115 rpm  
20 verschiedene Baugrößen:  
Drehmomentber. :5.000 - 470.000 Nm  
Drehzahlbereich : 0,1-115 U/min



P ...

**13 farklı büyüklükte;**  
**Moment aralığı: 1.000 - 135.000 Nm**  
**Tahvil oranları: 3,5 - 3000 arası**  
13 different sizes:  
Torque range: 1.000 - 135.000 Nm  
Transmission ratio: 3,5 - 3000  
13 verschiedene Baugrößen:  
Drehmomentber. : 1.000 - 135.000 Nm  
Übersetzung: 3,5 - 3000

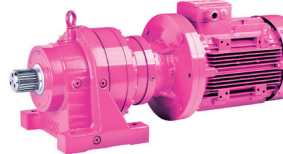

R ...

**13 farklı büyüklükte;**  
**Moment aralığı: 1.000 - 135.000 Nm**  
**Tahvil oranları: 3,5 - 3000 arası**  
13 different sizes:  
Torque range: 1.000 - 135.000 Nm  
Transmission ratio: 3,5 - 3000  
13 verschiedene Baugrößen:  
Drehmomentber. : 1.000 - 135.000 Nm  
Übersetzung: 3,5 - 3000



T ...

**10 farklı büyüklükte;**  
**Moment aralığı: 200 - 18.000 Nm**  
**Devir aralığı: 46 - 280 d/dak**  
10 different sizes:  
Torque range: 200-18.000 Nm  
Speed range: 46-280 rpm  
10 verschiedene Baugrößen:  
Drehmomentber. :200-18.000 Nm  
Drehzahlbereich : 46-280 U/min



# Genel Bilgiler

## General Information

### Einführung



#### D Serisi Redüktörlerin Genel Özellikleri

D Serisi redüktörler delik milli olmasından dolayı birçok uygulama alanı için montaj kolaylığı ve kompaktlık sağlamaktadır. Bu modeller flanşlı, gövde bağlantılı, delik milden askı bağlantılı veya bunların bir kombinasyonu olan montaj şekillerinde üretilmektedir.

Delik milli redüktörler sonsuz vidalı modellerde olduğu gibi modüler sistemde düşünülmüştür. Çıkış milleri ve çıkış flanşları, standart ürün üzerine sonradan ilave edilebilmektedir. Gövdenin her iki tarafından bağlanma imkanı sağlayan bağlantı delikleri mevcuttur. Delik milli redüktörlerin motor bağlantılarında da esneklik getirilmiştir. IEC B5 veya B14, standart akuple veya motorsuz mil girişli modeller mevcuttur. Diğer sonsuz ve monoblok modeller ile olan kombinasyonlarda değişiklikler minimum düzeye indirilmiştir. Yüksek mukavemet ve verimin ön plana çıktığı uygulama alanlarında, sonsuz vidalı redüktörlerin yerini almakta olup, radyal yükler açısından da büyük avantajlar sağlamaktadır.

YILMAZ REDÜKTÖR olarak tasarım prensibimiz;

- Yüksek teknoloji kullanmak
- Güvenilirlik,
- Yüksek güç yoğunluğu,
- Yüksek verim,
- Montaj uyumluluğu,
- Esnek çözümler

#### Dikkat Edilecek Hususlar !

- Bu katalogta verilen resimler görsel amaçlıdır ve şekilsel detaylar bağlayıcı değildir.

- YILMAZ REDÜKTÖR, ürünler ve kataloglar üzerinde, müşterileri bilgilendirmeksizin her türlü değişikliği yapma hakkına sahiptir.

- Ürünler teslim alındıktan sonra ürünle birlikte verilen kullanım kılavuzu okunmadan sistem devreye alınmamalıdır.

- Katalogta verilen yağ miktarları referans amaçlıdır. Gerçek yağ seviyesi için redüktör üzerinde bulunan yağ seviye tapası kullanılmalıdır. Yağ viskozitesi için, redüktör etiketine bakınız.

- Sipariş anında montaj pozisyonu bildirilmeyen redüktörler **M1** montajına uygun sevk edilir. Etiketle yazan montaj pozisyonundan farklı bağlanan redüktörler garanti kapsamından çıkar. Bu katalogta verilen redüktör ağırlıkları ortalama ağırlık değerleridir. Tahvil oranına ve üzerinde bağlı olan aksesuara göre ağırlıklar farklılık gösterebilir.

- Redüktörlerde oluşabilecek arızaları (mil kopması, dişi sıyırması vb.) dikkate alarak yaralanma ve hayati risk oluşumlarını önlemek için makine üreticisi veya kullanıcısı makine üzerinde veya redüktörün kullanılacağı yerde gerekli önlemleri almakta sorumludur.

#### General Specifications of D Series Gearboxes

*The speciality is the hollow shaft, which provides an advantage in mounting and makes the usage easier. These types are manufactured as flange mounted, foot mounted, hollow shaft mounted or combination of these mounting possibilities.*

*The hollow shaft gearboxes are manufactured in modular system. The output shaft and flange can be added to the standard hollow shaft gearbox without any change on the gearbox. The housing has mounting points on both sides, which allows mounting from both sides. The input side of hollow shaft gearboxes is flexible. IEC B5 or B14, standard coupled or with solid input shaft gearboxes are possible. The combination with other type gearboxes can be made with minimum change. In applications where efficiency and strength is most important hollow shaft gearboxes are preferred to worm gearboxes. Hollow shaft gearboxes have also advantages in overhung loads.*

*As we are YILMAZ REDÜKTÖR, our design principals are;*

- Using high technology
- Reliability
- High power density
- High efficiency
- Mounting compatible
- Flexible solutions

#### Attention to the following points !

*- Drawings are examples only and the details on the drawings or illustrations are not strictly binding.*

*- YILMAZ REDÜKTÖR reserve the right to make all kinds of changes in products and catalogues without any notice.*

*- Prior to commissioning, the operating instructions provided with the gearbox must be observed.*

*- Oil quantities given are guide values only. The exact quantity of oil should be checked by using the provided oil level plugs according mounting positions. For correct oil viscosity refer to the nameplate.*

*- If the mounting position is not informed upon ordering, the gear unit is delivered according **M1** mounting position. A different operation than the indicated mounting position on the name plate cancels the warranty. The weights given in this catalogue are mean values. Depending on the ratio and accessories the weights can differ.*

*- The machine manufacturer or user is responsible for taking the necessary precautions on the machine or at the place where the gearbox will be used, in order to prevent injury and life-threatening risks by taking into account the shaft, gear failures etc. that may occur in the gearboxes.*

#### Allgemeine Eigenschaften von D Serie Getrieben

Diese Ausführung ist sehr kompakt und leicht zum Montieren. Flansch, Fuß und Hohlwellenausführungen oder Kombinationsausführungen sind möglich. Diese Getriebe werden modular hergestellt.

Abtriebsflansch und Abtriebswelle kann man auf einen Standardausführung (Hohlwellen-antrieb) ohne Änderungen montieren. Die Gehäuse haben Stellen für Fußverbindung an den beiden Seiten. Deswegen ist diese Gehäuse von beiden Seiten montierbar. Flachgetrieben haben neue Montagemöglichkeiten auch für die Antriebsseite. Standard Verbindung (IEC B14 oder B5) oder Wellenantrieb ist möglich. Kombinationen mit anderen Getriebetypen sind leicht und mit wenigen Änderung. Wenn Wirkungsgrad und Festigkeit entscheidend bei der Anwendung ist, werden nicht Schneckengetrieben sondern Flachgetrieben bevorzugt. Flachgetrieben können höhere Querkräfte als andere Getriebe tragen.

Als YILMAZ REDÜKTÖR unsere Entwurfsprinzipien sind;

- Verwenden von hohen Fertigungstech.
- Hohe Betriebssicherheit
- Leistungsdichte
- Hoher Wirkungsgrad
- Universale Montagemöglichkeit
- Sonderlösungen

#### Bitte folgende Punkte beachten !

- Die Abbildungen sind beispielhaft und nicht verbindlich.

- Alle Änderungen auf dem Katalog und an der Produkte bleiben vorbehalten und können ohne Kenntnisnahme erfolgen.

- Vor Inbetriebnahme ist die mit gelieferter Betriebsanleitung zu beachten.

- Angaben über Ölmengen sind unverbindlich. Maßgebend ist die Ölstandsschraube in der geeigneten Montageposition. Ölviskosität und Sorte muss den Angaben des Typenschildes entsprechen.

- Wenn die Bauform bei Bestellung nicht angegeben ist, erfolgt die Lieferung in der Bauform **M1**. Wenn die Getriebe anders als auf dem Typenschild benannte Bauform eingesetzt werden, verliert die Garantie ihre Gültigkeit. Die angegebenen Gewichte sind unverbindliche Mittelwerte ohne Zubehör; genauere Gewichte sind abhängig von Zubehör und Übersetzung.

- Der Maschinenhersteller oder Betreiber ist dafür verantwortlich, an der Maschine oder am Einsatzort des Getriebes die notwendigen Maßnahmen zu treffen, um Verletzungen und Lebensgefahr unter Berücksichtigung von möglichen Wellen-, Getriebeausfällen etc. in den Getrieben zu vermeiden.

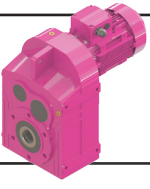

# Genel Bilgiler

## General Information

### Einführung



#### Teknik Tanımlamalar

##### - Çıkış Momenti ( $M_2$ ): [Nm]

Motorun verdiği momentin tahvil oranı ve verimle ile çarpılarak elde edilen değerdir. Redüktörün çıkışından alınabilecek moment gösterir.

##### - Anma Momenti ( $M_a$ ): [Nm]

Redüktörün  $f_s=1$  şartı için mekanik olarak taşıdığı moment değeridir.

##### - Nominal Güç ( $P_n$ ): [kW]

Nominal güç, redüktörün  $f_s=1$  şartı için mekanik olarak taşıyabileceği güç değeridir. Redüktörlerin nominal güçleri, güç devir tablolarında verilmiştir.

##### - Çevrim oranı (i):

Redüktörün giriş devrinin çıkış devrine oranıdır. Yılmaz Redüktör D serisi redüktörlerde 3,5-23500 arasında değişen çevrim oranları mevcuttur.

##### - Eşdeğer Güç ve Moment

$P_{eq}$  [kW],  $T_e$  [Nm]

Sabit devir altında ancak değişken yük değerlerinde çalışan redüktörlerde, sabit yük altında çalışma şartlarına eşdeğer gelen moment ve güç değerleridir. Hesaplama yöntemi sayfa 23'de verilmiştir.

##### - İhtiyaç güç ( $P_M$ ): [kW]

Redüktörlerin kullanılacağı uygulamanın istenilen şekilde çalışabilmesi için ihtiyaç duyduğu güç değeridir.

##### - İhtiyaç moment (T): [Nm]

Redüktörün kullanılacağı uygulamanın çalışabilmesi için ihtiyaç duyduğu moment değeridir. Seçilen redüktör için her zaman çıkış momentini eşit yada daha düşük olmalıdır.

##### - Müsade Edilen Eksenel ve Radyal Yükler

$F_{qem}$ ,  $F_{qam}$ : [N]

Redüktörün giriş veya çıkış milinde müsade edilen eksenel ve radyal yüklerdir.

##### - Servis Faktörü ( $f_s$ ):

Redüktörün çalıştığı şartlar ile uyumlu olması için gerekli olan emniyet katsayısıdır.  $f_s=1$ , düzgün ve sakin yüklerde, günlük sekiz saat, saatte 100 dur-kalk çalışmayı karşılar. Detaylar için redüktör seçim bölümüne bakınız.

#### Teknik Özellikler:

##### - Ses seviyesi:

Redüktörlerimiz ses seviyesi VDI 2159' da verilen redüktörler için müsade edilen ses seviyelerinin altındadır.

##### - Boya ve Korozyon Koruması:

Redüktörlerin standart rengi DIN1843'e göre RAL 7030 dur. İstek üzerine farklı renklerde boyanabilir. Nemli ve korozyon bölgeleri için istek üzerine farklı boya uygulanabilir.

#### Technical Explanations

##### - Output Torque ( $M_2$ ): [Nm]

Multiplication of motor output torque with transmission ratio and efficiency gives the result of output torque at the output shaft of the gear unit.

##### - Nominal Torque ( $M_a$ ): [Nm]

Nominal torque is the mechanical torque which the gearbox can resist under  $f_s=1$  conditions.

##### - Nominal Power ( $P_n$ ): [kW]

The nominal power is the power which gearbox can mechanically resist under  $f_s=1$  condition. The nominal powers are given on the performance tables.

##### - Ratio (i):

Ratio between output shaft speed and input shaft speed. Available ratios of Yılmaz Redüktör M series are between 3,5 to 23500.

##### - Equivalent Power and Torque

$P_{eq}$ : [kW],  $T_e$  [Nm]

For gearbox unit with constant speed but variable working conditions: This is the calculated power or torque which is equivalent to the values at working under constant working conditions.

##### - Required Power ( $P_M$ ): [kW]

Required power for the applications which is able to drive the system.

##### - Required Torque (T): [Nm]

Required torque for applications. Required torque always must be equal or smaller than output torque for selected gearbox.

##### - Permissible Axial and Overhung Loads:

$F_{qem}$ ,  $F_{qam}$  [N]

Permissible axial and overhung load at the output or input shaft of gearboxes.

##### - Service Factor ( $f_s$ ):

Service factor is a safety coefficient, which takes into account the different running conditions of the driven machine.  $f_s=1$  is used for uniform loads 8 hours working per day and up to 100 cycle per hour.

#### Technical Specifications:

##### - Noise Level:

The noise level of our gearboxes is below the permitted values defined in VDI guidelines 2159 for gear units.

##### - Coating and Corrosion Protection:

The gearboxes are painted with RAL 7030 according DIN1843. Different colors are available upon request. Paintings for high humidity or chemically aggressive environments are available upon request.

#### Technische Erläuterungen

##### - Ausgangsmoment ( $M_2$ ): [Nm]

Multiplikation von Ausgangsmoment des Motors mit Übersetzung und Division das Ergebnis mit Wirkungsgrad ergibt den Betrag von Ausgangsmoment der Getriebe.

##### - Nennmoment ( $M_a$ ): [Nm]

Mechanisches Belastungsmoment der Getriebe unter dem Bedingung  $f_s=1$ .

##### - Nennleistung ( $P_n$ ): [kW]

Die Nennleistung ist die mechanische Grenzfestigkeitsleistung für  $f_s=1$ . Kann von der Leistung-Drehzahltafel abgelesen werden.

##### - Übersetzung (i):

Wird aus dem Verhältnis von Ausgang- zu Eingangswinkelgeschwindigkeit bestimmt. Gängige Übersetzungen von Yılmaz M Serie Getriebe liegt zwischen 3,5 bis 23500.

##### - Äquivalente Leistung und Moment

$P_{eq}$ : [kW],  $T_e$  [Nm]

Für mit konstanten Drehzahl aber unter veränderlichen Betriebsbedingungen arbeitende Getriebe berechnete Leistung und Moment äquivalent zu Werten beim Arbeiten unter konstanten Betriebsbedingungen.

##### - Notwendige Leistung ( $P_M$ ): [kW]

Für das Getriebe notwendige Leistung, um Arbeiten von Getriebe bei der für das Getriebe gedachten Anwendung zu gewährleisten.

##### - Notwendige Moment (T): [Nm]

Notwendige Moment für Anwendungen. Für den ausgewählte Getriebe soll das notwendige Moment gleich dem Ausgangsmoment oder kleiner als diesem Moment sein.

##### - Zulässige Axial- oder Querkräfte:

$F_{qem}$ ,  $F_{qam}$  [N]

Bei der Anwendungen während der Betrieb zulässige axiale oder radiale Eingangs- oder Ausgangsbelastungen.

##### - Betriebsfaktor ( $f_s$ ):

Dieser Faktor  $f_s$  ist ein Sicherheitsfaktor, damit die Getriebe unter verschiedenen Bedingungen mit genügender Sicherheit arbeitet.  $f_s=1$  gilt für gleichförmig Belastung, mit 8 Betriebsstunden pro Tag und bis zum 100 Schaltungen pro Stunde.

#### Technische Informationen:

##### - Geräuschpegel:

Geräuschstärken aller Getriebe bleiben unter die zulässigen Werte, die für die Getriebe in der VDI-Richtlinie 2159 festgelegt sind.

##### - Lackierung und Korrosionsschutz:

Die Getriebe werden mit der Farbe RAL 7030 nach DIN1843 lackiert. Auf Wunsch sind Sonderlackierungen möglich. Alle Getriebe können auf Wunsch auch in korrosionsgeschützter Ausführung für aggressive Umgebungen geliefert werden.



# Genel Bilgiler

## General Information

### Einführung



#### - Yağlama:

D Serisi redüktörler yağlama tablolarında verilen yağlar ile doldurulmaktadır. Yağ detayları için yağlama bölümüne bakınız.

#### - Aksesuarlar:

D Serisi redüktörlerde aşağıdaki aksesuarlar kullanılabilir

- IEC B5/B14 Motor bağlantı flanşları
- Çıkış Bağlantı Flanşları
- Sıkma bileziği
- Geri dönüş kilidi
- Özel keçe çözümleri,
- Şeffaf yağ seviye göstergesi
- Tork kolu
- Elektromanyetik frenler

Diğer özel aksesuarlar için lütfen, YILMAZ REDÜKTÖR ile temasa geçiniz.

#### - Yüzey Koruması

Redüktörlerimiz aksi belirtilmedikçe boyalı olarak sevk edilmektedir. DIN EN ISO 12944-2 korozyon standardında belirtilen sınıflardan aşağıdaki tabloda belirtilen 4 kategori için yüzey koruması sağlanmaktadır. Standart boya sınıfımız C2 korozyon kategorisini karşılamaktadır. Farklı bir koruma sınıfı istenirse sipariş aşamasında belirtilmelidir.

Mil, flanş bağlantı yüzeyi gibi boyanmayan yüzeylere paslanmaya karşı koruma sağlamak için korozyon önleyici yağ sürülmektedir.

#### - Lubrication:

*D series of gearboxes filled with oils which is indicated on lubrication tables. For lubrication details please refer to the lubrication section.*

#### - Accessories:

*The following accessories can be applied to D series gearboxes.*

- IEC B5/B14 Motor connection flange
- Output flanges
- Shrink Discs
- Backstops
- Special sealing solutions.
- Transparent oil level indicator,
- Torque arm
- Electromagnetic brakes

*For other accessories please contact, YILMAZ REDÜKTÖR.*

#### - Surface Protection

*Our products are all painted unless otherwise stated. 4 corrosion categories which are mentioned below can be offered according to corrosion categories of DIN EN ISO 12944-2 standard. Our standard paint meets C2 corrosion category. If different category is requested, please inform before order.*

*Unpainted parts such as shaft, flange connection surface are coated with anti-corrosion paint before shipment against corrosion.*

#### - Schmierung:

D Serie Getriebe werden mit Ölen entsprechend der Schmierungstabellen, falls nicht anders vereinbart, geliefert. Für weitere Schmierungsangaben siehe Kapitel Schmierung.

#### - Zubehör:

Folgendes Zubehör kann für Getriebe der D Serie geliefert werden.

- IEC B5/B14 Motor Adapter,
- Abtriebsflansch,
- Schrumpfscheiben,
- Rücklaufsperrn,
- Unterschiedliche Dichtungssysteme,
- Drehmomentarm
- Elektromagnetische Bremsen

Für weiteres Zubehör kontaktieren Sie bitte mit, YILMAZ REDÜKTÖR.

#### - Oberflächenschutz

Getriebe von Yılmaz Redüktör werden lackiert und so geliefert falls nicht anders vereinbart ist. Die 4 untenstehenden Korrosionskategorien können nach Korrosionsschutz-Basisnorm DIN EN ISO 12944-2 angeboten werden. Unsere Standard-Lackierung erfüllt C2-Korrosionskategorie. Wenn Sie eine andere Kategorie erwünschen, informieren Sie uns bitte darüber vor der Bestellung.

Nicht lackierte Teile (z.B. Welle, Oberfläche des Anschlussflanschs) werden mit einem Schutzmittel vor dem Versand geschmiert, um vor Korrosion und Rost zu schützen.

Korozyon Kategorisi Corrosion Categories Korrosivitätskategorie	Çevre Şartları Ambient Conditions Umgebungsbedingungen	Boya Tipi Paint Type Lackierung	Boya Kalınlıkları Paint Thickness Sollschichtdicke
C2 (Standard)	<b>İç ortam ve muhafazalı dış ortam</b> <b>Nem ve kirlilik oranı düşük çalışma ortamı</b> <i>Indoor installation and outdoor installation with protection roof</i> <i>Environments with low humidity and contamination</i> Innenaufstellung und Außenaufstellung mit Überdachung oder Schutzzeineinrichtung Atmosphäre mit niedriger Luftfeuchtigkeit und Verunreinigung	<b>Çift Komponent Astar</b> <i>Two-Component Primer Coat</i> Zwei-Komponente Grundierung	60 µm
		<b>Akrilik Sonkat</b> <i>Acrylic Top Coat</i> Akryl-Decklack	40 µm
C3	<b>İç ortam ve atmosfere açık dış ortam</b> <b>Orta seviyede nem ve kirlilik olan çalışma ortamı</b> <i>Indoor installation and outdoor installation subject to weathering</i> <i>Environments with mean humidity and contamination</i> Innenaufstellung und Außenaufstellung im Freien unter Bewitterung Atmosphäre mit mäßiger Luftfeuchtigkeit und Verunreinigung	<b>Epoksi Astar</b> <i>Epoxy Primer Coat</i> Epoxy-Grundierung	80 µm
		<b>Akrilik Sonkat</b> <i>Acrylic Top Coat</i> Akryl-Decklack	40 µm
C4	<b>İç ortam ve atmosfere açık dış ortam</b> <b>Genelde yüksek nem ve kimyasal madde olan çalışma ortamı</b> <i>Indoor installation and outdoor installation subject to weathering</i> <i>Environments with occasionally high humidity and chemical contamination</i> Innenaufstellung und Außenaufstellung im Freien unter Bewitterung Atmosphäre gelegentlich mit hoher Luftfeuchtigkeit und chemischer Verunreinigung	<b>Epoksi Astar</b> <i>Epoxy Primer Coat</i> Epoxy-Grundierung	180 µm
		<b>Akrilik Sonkat</b> <i>Acrylic Top Coat</i> Akryl-Decklack	40 µm
C5-I / C5-M	<b>İç ortam ve atmosfere açık dış ortam</b> <b>Sürekli yüksek nem ve kimyasal madde ile temizlik yapılan çalışma ortamı</b> <i>Indoor installation and outdoor installation subject to weathering</i> <i>Environments with permanent high humidity and chemical cleaning contamination</i> Innenaufstellung und Außenaufstellung im Freien unter Bewitterung Atmosphäre mit ständiger hoher Luftfeuchtigkeit und chemischer Verunreinigung (Nassreinigung mit Säuren/Laugen und auch mit chemischen Reinigungsmitteln).	<b>Çinko Yüklemeli Epoksi Astar</b> <i>Epoxy Zinc Primer Coat</i> Epoxy-Zink-Grundierung	70 µm
		<b>Epoksi Astar Miox</b> <i>Epoxy Miox Primer Coat</i> Epoxy-Miox-Grundierung	150 µm
		<b>Akrilik Sonkat</b> <i>Acrylic Top Coat</i> Akryl-Decklack	40 µm

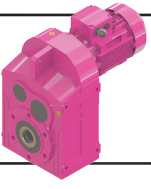

Genel Bilgiler  
General Information  
Einführung



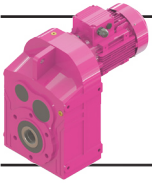

# Genel Bilgiler General Information Einführung



Tip Tanımlaması / Unit Designation / Typenbezeichnung

**D R 4 7 4 .02 3 E90S / 4C - L02**

**Fren / Brake / Bremse**

L-220V **Fanlı / With Fan / Mit Lüfter**  
P-24V **Fanlı / With Fan / Mit Lüfter**  
S-220 V **Fansız / Without Fan / Ohne Lüfter**  
Z-24 V **Fansız / Without Fan / Ohne Lüfter**

01-10 Nm    10-100 Nm  
02-25 Nm    20-200 Nm  
04-40 Nm    30-300 Nm  
05-50 Nm    40-400 Nm

**Kutup sayısı / Number of poles / Anzahl der Polen**

**Motor Büyüklüğü / Motor Size / Motorbaugröße**

**DR / DV tipleri için / For DR /  
DV / Types / Für die Typen DR  
/ DV**

**DN tipleri için / For DN Types / Für Typen DN**

<b>A06</b> :63 B5	<b>A09</b> : 90 B5	<b>A13</b> :132 B5	<b>A25</b> : 250 B5
<b>B06</b> :63 B14	<b>B09</b> : 90 B14	<b>B13</b> :132 B14	<b>A28</b> : 280 B5
<b>A07</b> :71 B5	<b>A10</b> :100 B5	<b>A16</b> :160 B5	<b>A31</b> : 315 B5
<b>B07</b> :71 B14	<b>B10</b> :100 B14	<b>A18</b> :180 B5	
<b>A08</b> :80 B5	<b>A11</b> :112 B5	<b>A20</b> :200 B5	
<b>B08</b> :80 B14	<b>B11</b> :112 B14	<b>A22</b> :225 B5	

**E90S / 4**

**Kutup Sayısı / Pole Number /  
Anzahl der Polen**

**Gövde uzunluğu / Frame Length /  
Gehäuselänge des Motors**

**Motor büyüklüğü / Motor size /  
Motorbaugröße**

**Motor tipi / Motor type /  
Motortyp**

**Motor Verim Sınıfı / Motor Efficiency Class / Motor-Effizienzklasse**

**Çıkış Mili Özelliği / Output Shaft / Eigenschaft der Ausgangswelle**

**00** :Standart delik milli / Hollow Shaft output / Stand. Ausführung mit Hohlwelle

**01** :Mil Çıkışlı / Solid Shaft Output / Vollwelle

**02** :Flanşlı ve mil çıkışlı / Solid shaft output with IEC B5 /14 Flange / Flansch und Abtriebswelle

**03** :Flanşlı ve delik milli çıkışlı / Flanged and Hollow Shaft output / Mit Flansch und Hohlaustragswelle

**0S** :Sıkma Bilezikli / Shrink Disk Output / Schrumpfscheibe

**0E** :Ekstruder Çıkışlı / Extruder Output / Extruder-Ausgang

**0A** :Karıştırıcı Redüktörü Delik Mil Çıkışlı / Drywell Gearbox with Hollow Output Shaft / Drywell Getriebe mit Hohlwelle

**1A** :Karıştırıcı Redüktörü Dolu Mil Çıkışlı / Drywell Gearbox with Solid Output Shaft / Drywell Getriebe mit Vollwelle

**SA** :Karıştırıcı Redüktörü Sıkma Bilezikli Çıkışlı / Drywell Gearbox with Shrink Disk Output / Drywell Getriebe mit Schrumpfscheibe

**Kademe Sayısı / Stage / Anzahl der Stufen**

**2 Kademe / 2 Stages / 2 stufig**

**5 Kademe / 5 Stages / 5 stufig**

**3 Kademe / 3 Stages / 3 stufig**

**6 Kademe / 6 Stages / 6 stufig**

**4 Kademe / 4 Stages / 4 stufig**

**Revizyon Numarası / Revision Number / Änderungsnummer**

**Gövde Büyüklük / Housing Size / Größe der Gehäuse**

0...9

**Giriş Tipi / Input Type / Eingangstyp**

**R** :Motorlu / With Motor / Mit Motor

**N** :Motorsuz ve IEC B5/B14 Flanş Girişli / IEC B5 / B14 Flanged without Motor / Ohne Motor und IEC B5/B14 Eingangsflansch

**V** :Motorlu ve IEC B5/B14 Flanş Girişli / IEC B5 / B14 Flanged with Motor / Mit Motor und IEC B5/B14 Eingangsflansch

**T** :Motorsuz / Without Motor / Eingang ohne Motor

**RB** :Motorlu Karıştırıcı Redüktörü / Drywell Gearbox With Motor / Drywell Getriebe mit Motor

**NB** :Motorsuz ve IEC B5/B14 Flanş girişli Karıştırıcı Redüktörü / IEC B5 / B14 Flanged Drywell Gearbox without Motor / Drywell Getriebe Ohne Motor und mit IEC B5/B14 Eingangsflansch

**VB** :Motorlu ve IEC B5/B14 Flanş girişli Karıştırıcı Redüktörü / IEC B5 / B14 Flanged Drywell Gearbox with Motor / Drywell Getriebe Mit Motor und IEC B5/B14 Eingangsflansch

**TB** :Motorsuz Karıştırıcı Redüktörü / Drywell Gearbox Without Motor / Drywell Getriebe mit Eingangsvollwelle ohne Motor

**Redüktör Tipi / Gearbox Type / Getriebe**

**D Serisi / D Serie / D Serie**

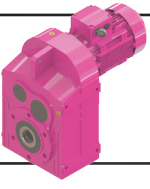

# Genel Bilgiler

## General Information

### Einführung



#### Tip Tanımlaması / Unit Designation / Typenbezeichnungen

- DR..00.. **Delik milli tip helisel redüktörler, motor bağlantılı, delik milli çıkış / Hollow shaft helical geared motors , Direct coupled motor, Hollow shaft output /** Flachtriebemotoren, Verbunden mit Motor, Ausgang mit Hohlwelle.
- DR..01.. **Delik milli tip helisel redüktörler, motor bağlantılı, milli çıkış / Hollow shaft helical geared motors, Direct motor coupled, solid output shaft /** Flachtriebemotoren, Verbunden mit Motor, Ausgang mit Vollwelle.
- DR..02.. **Delik milli tip helisel redüktörler, motor bağlantılı, mil ve flanş çıkışı / Hollow shaft helical geared motors, Direct motor coupled, Solid output shaft and output flange /** Flachtriebemotoren, Verbunden mit Motor, Ausgang mit Vollwelle und Flansch.
- DR..03.. **Delik milli tip helisel redüktörler, motor bağlantılı delik milli ve flanş çıkışı / Hollow shaft helical geared motors, Direct motor coupled, Hollow output shaft and output flange /** Flachtriebemotoren, Verbunden mit Motor, Ausgang mit Hohlwelle und Flansch.
- DR..0S.. **Delik milli tip helisel motorlu redüktörler, motor bağlantılı, sıkma bilezik çıkışı / Hollow Shaft helical geared motors Direct motor coupled , Shrink disk output /** Flachtriebemotoren, Verbunden mit Motor, Ausgang mit Schrupfscheibe
- DR..0E.. **Delik milli tip helisel motorlu redüktörler, motor bağlantılı, ekstruder çıkışı / Hollow Shaft helical geared motors Direct motor coupled , extruder output /** Flachtriebemotoren, Verbunden mit Motor, Ausgang mit extruder
- 
- DN..00.. **Delik milli tip helisel redüktörler, IEC B5/B14 flanşlı motorsuz , delik milli çıkış / Hollow shaft helical gearboxes, IEC B5/B14 flanged input without motor, hollow output shaft /** Flachgetriebe, ohne Motor mit IEC B5/B14 Flansch , Ausgang mit Hohlwelle.
- DN..01.. **Delik milli tip helisel redüktörler, IEC B5/B14 flanşlı motorsuz , mil çıkışı / Hollow shaft helical gearboxes, IEC B5/B14 flanged input without motor, Solid output shaft /** Flachgetriebe, ohne Motor mit IEC B5/B14 Flansch, Ausgang mit Vollwelle.
- DN..02.. **Delik milli tip helisel redüktörler, IEC B5/B14 flanşlı motorsuz, mil ve flanş çıkışı / Hollow shaft helical gearboxes, IEC B5/B14 flanged input without motor, Solid output shaft and output flange /** Flachgetriebe, ohne Motor mit IEC B5/B14 Flansch, Ausgang mit Vollwelle und Flansch.
- DN..03.. **Delik milli tip helisel redüktörler, IEC B5/B14 flanşlı motorsuz, delik milli ve flanş çıkışı / Hollow shaft helical gearboxes, IEC B5/B14 flanged input without motor, Hollow output shaft and output flange /** Flachgetriebe, ohne Motor mit IEC B5/B14, Ausgang mit Hohlwelle und Flansch.
- DN..0S.. **Delik milli tip helisel redüktörler, IEC B5/B14 flanşlı motorsuz, sıkma bilezik çıkışı / Hollow Shaft helical geared motors IEC B5/B14 flanged without motor, Shrink disk Output /** Flachtriebemotoren, ohne Motor mit IEC B5/B14, Ausgang mit Schrupfscheibe
- DN..0E.. **Delik milli tip helisel redüktörler, IEC B5/B14 flanşlı motorsuz, ekstruder çıkışı / Hollow Shaft helical geared motors IEC B5/B14 flanged without motor, extruder output /** Flachtriebemotoren, ohne Motor mit IEC B5/B14, Ausgang mit extruder.
- 
- DV..00.. **Delik milli tip helisel redüktörler, IEC B5/B14 flanşlı motor bağlantılı, delik milli çıkış / Hollow shaft helical gearboxes, IEC B5/B14 flanged input with direct motor coupled, hollow output shaft /** Flachgetriebe, Verbunden mit IEC B5/B14 Motorverbindung, Ausgang mit Hohlwelle.
- DV..01.. **Delik milli tip helisel redüktörler, IEC B5/B14 flanşlı motor bağlantılı, mil çıkışı / Hollow shaft helical gearboxes, IEC B5/B14 flanged input with direct coupled motor, Solid output shaft /** Flachgetriebe, Verbunden mit IEC B5/B14 Motorverbindung, Ausgang mit Vollwelle.
- DV..02.. **Delik milli tip helisel redüktörler, IEC B5/B14 flanşlı motor bağlantılı, mil ve flanş çıkışı / Hollow shaft helical gearboxes, IEC B5/B14 flanged input with direct coupled motor, Solid output shaft and output flange /** Flachgetriebe, Verbunden mit IEC B5/B14 Motorverbindung, Ausgang mit Vollwelle und Flansch.
- DV..03.. **Delik milli tip helisel redüktörler, IEC B5/B14 flanşlı motor bağlantılı, delik milli ve flanş çıkışı / Hollow shaft helical gearboxes, IEC B5/B14 flanged input with direct coupled motor, Hollow output shaft and output flange /** Flachgetriebe, Verbunden mit IEC B5/B14 Motorverbindung, Ausgang mit Hohlwelle und Flansch.
- DV..0S.. **Delik milli tip helisel redüktörler, IEC B5/B14 flanşlı motor bağlantılı , sıkma bilezik çıkışı / Hollow Shaft helical geared motors IEC B5/B14 flanged with direct coupled motor, Shrink disk Output /** Flachtriebemotoren, Verbunden mit IEC B5/B14 Motorverbindung, Ausgang mit Schrupfscheibe
- DV..0E **Delik milli tip helisel redüktörler, IEC B5/B14 flanşlı motor bağlantılı , ekstruder çıkışı / Hollow Shaft helical geared motors IEC B5/B14 flanged with direct coupled motor, Extruder Output /** Flachtriebemotoren, Verbunden mit IEC B5/B14 Motorverbindung, Ausgang mit extruder.
- 
- DT..00.. **Delik milli tip helisel redüktörler, motorsuz ve mil girişli, delik milli çıkış / Hollow shaft helical geared unit, Solid shaft input without motor, Hollow output shaft /** Flachgetriebe, Eingang mit Vollwelle ohne Motor, Ausgang mit Hohlwelle.
- DT..01.. **Delik milli tip helisel redüktörler, motorsuz ve mil girişli, mil çıkışı / Hollow shaft helical geared units, Solid shaft input without motor, Solid output shaft /** Flachgetriebe, Eingang mit Vollwelle ohne Motor, Ausgang mit Vollwelle.
- DT..02.. **Delik milli tip helisel redüktörler, motorsuz ve mil girişli, mil ve flanş çıkışı / Hollow shaft helical gear units, Solid shaft input without motor, Solid output shaft and flange output /** Flachgetriebe, Eingang mit Vollwelle ohne Motor, Ausgang mit Vollwelle und Flansch.
- DT..03.. **Delik milli tip helisel redüktörler, motorsuz ve mil girişli, delik milli ve flanş çıkışı / Hollow shaft helical gear units, solid shaft input without motor, Hollow output shaft and output flange /** Flachgetriebe, Eingang mit Vollwelle ohne Motor, Ausgang mit Hohlwelle und Flansch.
- DT..0S.. **Delik milli tip helisel redüktörler, motorsuz, sıkma bilezik çıkışı / Hollow Shaft helical gear motors, Solid shaft input without motor, Shrink Disk Output /** Flachgetriebe, ohne Motor, Ausgang mit Schrupfscheibe
- DT..0E.. **Delik milli tip helisel redüktörler, motorsuz, ekstruder çıkışı / Hollow Shaft helical gear motors, Solid shaft input without motor, Extruder Output /** Flachgetriebe, ohne Motor, Ausgang mit extruder.

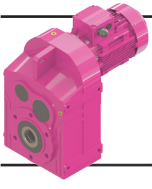

**Genel Bilgiler**  
*General Information*  
Einführung

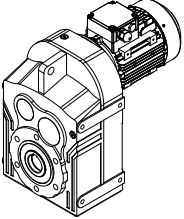
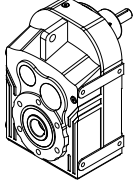
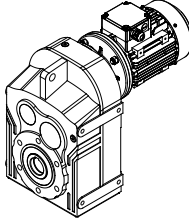
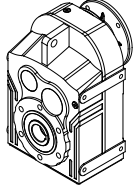
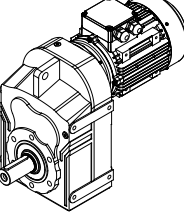
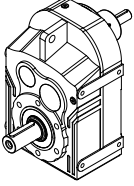
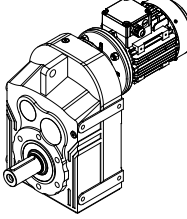
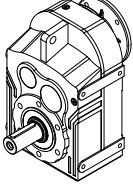
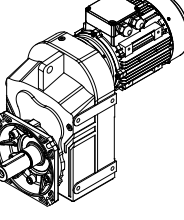
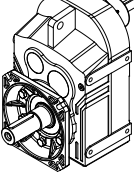
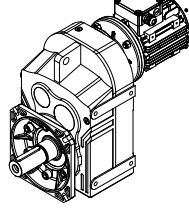
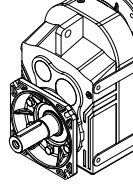
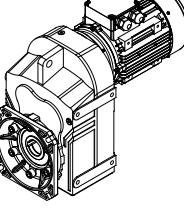
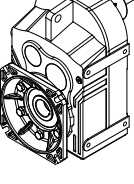
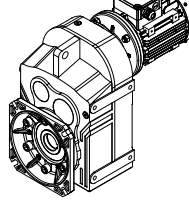
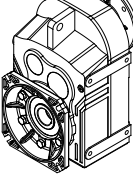
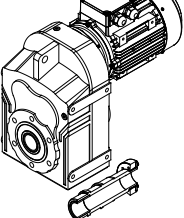
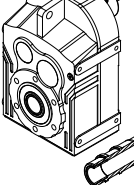
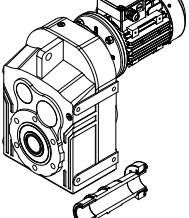
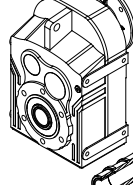
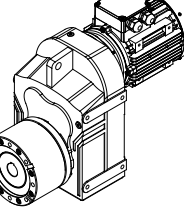
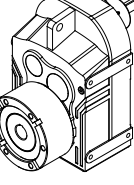
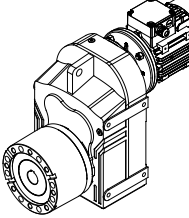
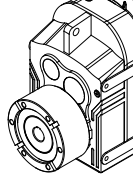

Tip Tanımlaması / Unit Designation / Typenbezeichnungen

 <b>DR..00</b>	 <b>DT..00</b>	 <b>DV..00</b>	 <b>DN..00</b>
 <b>DR..01</b>	 <b>DT..01</b>	 <b>DV..01</b>	 <b>DN..01</b>
 <b>DR..02</b>	 <b>DT..02</b>	 <b>DV..02</b>	 <b>DN..02</b>
 <b>DR..03</b>	 <b>DT..03</b>	 <b>DV..03</b>	 <b>DN..03</b>
 <b>DR..0S</b>	 <b>DT..0S</b>	 <b>DV..0S</b>	 <b>DN..0S</b>
 <b>DR..0E</b>	 <b>DT..0E</b>	 <b>DV..0E</b>	 <b>DN..0E</b>

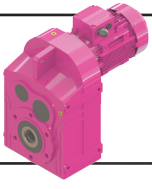

# Genel Bilgiler

## General Information

### Einführung



#### Örnek Tip Tanımlamaları

##### DR172.00 - 3E90S/4C - L05

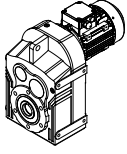

**D**.....: D serisi redüktör  
**R**.....: Motor bağlantılı  
**1**.....: Gövde büyüklük  
**7**.....: Revizyon numarası  
**2**.....: Kademe sayısı  
**00**.....: Delik mil çıkışı  
**3**.....: Verim sınıfı  
**E**.....: Motor tipi  
**90S**.....: Motor büyüklüğü  
**4C**.....: Motor kutup sayısı  
**L05**.....: Fren Tipi

#### DT373.01

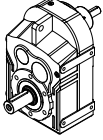

**D**.....: D serisi redüktör  
**T**.....: Motorsuz giriş millisi  
**3**.....: Gövde büyüklüğü  
**7**.....: Revizyon numarası  
**3**.....: Kademe sayısı  
**01**.....: Mil çıkışı

#### DN473.03 - A11

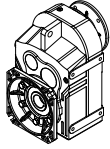

**D**.....: D serisi redüktör  
**N**.....: Motorsuz ve IEC B5 giriş flanşlı  
**4**.....: Gövde büyüklüğü  
**7**.....: Revizyon numarası  
**3**.....: Kademe sayısı  
**03**.....: Delik millisi flanş bağlantılı  
**A11**.....: 112 tip motor, B5 bağlantı flanş

#### DV573.0S - 3E100L/4C

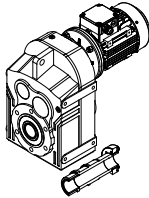

**D**.....: D serisi redüktör  
**V**.....: Motorlu ve B5/B14 giriş flanşlı  
**5**.....: Gövde büyüklüğü  
**7**.....: Revizyon numarası  
**3**.....: Kademe sayısı  
**0S**.....: Sıkma bilezikli delik millisi  
**3**.....: Verim sınıfı  
**E**.....: Motor tipi  
**100L/4**.....: Motor büyüklüğü ve kutup sayısı

#### Sample Designations

##### DR172 - 3E90S/4C - L05

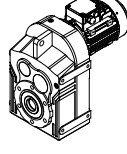

**D**.....: D series gearbox  
**R**.....: With motor connection  
**1**.....: Gear unit size  
**7**.....: Revision number  
**2**.....: Stage number  
**00**.....: Hollow shaft output  
**3**.....: Efficiency class  
**E**.....: Motor type  
**90S**.....: Motor frame size  
**4C**.....: Number of poles  
**L05**.....: Brake type

#### DT373.01

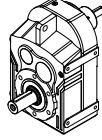

**D**.....: D series gearbox  
**T**.....: Solid input shaft  
**3**.....: Gear unit size  
**7**.....: Revision number  
**3**.....: Stage number  
**01**.....: Solid output shaft

#### DN473.03 - A11

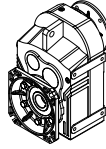

**D**.....: D series gearbox  
**N**.....: IEC B5 flange without motor input  
**4**.....: Gear unit size  
**7**.....: Revision number  
**3**.....: Stage number  
**03**.....: Hollow shaft output with flange  
**A11**.....: Motor type 112, B5 flange

#### DV573.0S - 3E100L/4C

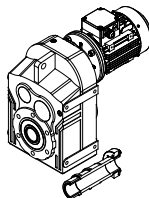

**D**.....: D series gearbox  
**V**.....: With Motor, B5/B14 input flange  
**5**.....: Gear unit size  
**7**.....: Revision number  
**3**.....: Stage number  
**0S**.....: Hollow shaft output with shrink disk  
**3**.....: Efficiency class  
**E**.....: Motor type  
**100L/4**.....: Motor size and number of poles

#### Beispiele für Typenbezeichnung

##### DR172 - 3E90S/4C - L05

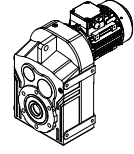

**D**.....: D Serie Getriebe  
**R**.....: Motorverbindung  
**1**.....: Größe des Gehäuses  
**7**.....: Änderungsnummer  
**2**.....: Stufenanzahl  
**00**.....: Hohlansgangswelle  
**3**.....: Effizienzklasse  
**E**.....: Motortyp  
**90S**.....: Motorbaugröße  
**4C**.....: Polenzahl  
**L05**.....: Bremse

#### DT373.01

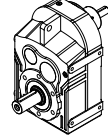

**D**.....: D Serie Getriebe  
**T**.....: Vollwelleneingang ohne Motor  
**3**.....: Größe des Gehäuses  
**7**.....: Änderungsnummer  
**3**.....: Stufenanzahl  
**01**.....: Vollwelle

#### DN473.03 - A11

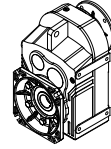

**D**.....: D Serie Getriebe  
**N**.....: IEC B5 Flansch ohne Motor  
**4**.....: Größe des Gehäuses  
**7**.....: Änderungsnummer  
**3**.....: Stufenanzahl  
**03**.....: Hohlwelle mit Flanschverbindung  
**A11**.....: Motortyp 112, B5 Motorflansch

#### DV573.0S - 3E100L/4C

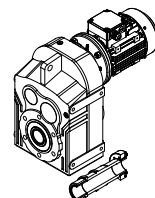

**D**.....: D Serie Getriebe  
**V**.....: Mit Motor und IEC B5/B14 Flansch  
**5**.....: Größe des Gehäuses  
**7**.....: Änderungsnummer  
**3**.....: Stufenanzahl  
**0S**.....: Hohlwelle mit Schrumpfscheibe  
**3**.....: Effizienzklasse  
**E**.....: Motortyp  
**100L/4**.....: Motorbaugröße und Anzahl der Pole

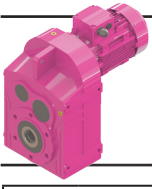

# Genel Bilgiler

## General Information

### Einführung



### Motor Büyüklüğüne Göre Geometrik Mümkün Çevrim Oranları

Geometrically Possible Combinations of Ratios According to Motor Size

Geometrisch mögliche Kombinationen von Übersetzungen nach Motorbaugröße

#### Motor Büyüklüğü / Motor Size / Motorbaugröße

Tip Type Typ	Kademe Stages Stufen	63	71	80	90	100	112	132
DR072	2	5,77-36,86	5,77-36,86	5,77-36,86	5,77-25,01	5,77-15,97	-	-
DR073	3	35,43-180,05	35,43-180,05	35,43-85,12; 146,60-180,05	35,43-85,12	35,43-38,18; 67,62-72,87	-	-
DR172	2	4,86-29,67	4,86-29,67	4,86-21,79	4,86-21,79	4,86-19,04	-	-
DR173	3	27,18-142,89	27,18-142,89	27,18-103,34	27,18-103,34	27,18-91,25	-	-
DR272	2	4,98-25,78	4,98-25,78	4,98-25,78	4,98-25,78	4,98-22,67	-	-
DR273	3	25,44-137,94	25,44-137,94	25,44-137,94	25,44-137,94	25,44-120,49	-	-
DR275	5	150,45-1189,30	150,45-1189,30	150,45-1189,30	150,45-1189,30	150,45-214,95 331,04-356,74	-	-
DR276	6	1215,13-2907,19	1215,13-2907,19	1215,13-2907,19	1215,13-2907,19	-	-	-
DR282	2	5,22-6,65 9,45-29,85	5,22-6,65 9,45-29,85	5,22-6,65 9,45-29,85	4,52-6,65 8,19-29,85	3,92-24,79	3,92-18,73	3,92-14,06
DR283	3	41,23-135,52	41,23-135,52	41,23-135,52	35,35-135,52	30,28-119,16	30,28-84,12	30,28-62,55
DR285	5	127,94-936,69	127,94-936,69	127,94-936,69	127,94-936,69	127,94-137,88 196,84-298,73	-	-
DR286	6	1003,2-3800,21	1003,2-3800,21	1003,2-2692,99	1003,2-2692,99	-	-	-
DR372	2	14,74-25,42	14,74-25,42	14,74-25,42	5,05-5,79 10,25-11,77 14,74-25,42	3,65-25,42	3,65-22,46	3,65-17,65
DR373	3	32,11-171,89	32,11-171,89	32,11-171,89	27,53-171,89	23,58-151,15	23,58-106,69	23,58-79,34
DR375	5	174,88-1188,1	174,88-1188,10	174,88-1188,10	174,88-1188,10	174,88 249,67-378,91	-	-
DR376	6	1272,5-4820,21	1272,5-4820,21	1272,5-3415,8	1272,5-3415,8	-	-	-
DR472	2	-	20,74-24,54	20,74-24,54	7,54 ; 15,02-17,01 20,74-24,54	6,71-7,54 13,35-24,54	6,71-7,54 13,35-24,54	4,48-24,54
DR473	3	-	95,87-242,68	95,87-242,68	47,37-54,35 70,59-81,00 95,87-242,68	34,28-174,97	28,45-154,63	28,45-121,49
DR474	4	219,13-584,15	219,13-584,15	219,13-584,15	219,13-584,15	219,13-316,37	219,13	-
DR475	5	648,55-1937,71	648,55-1937,71	648,55-1937,71	648,55-1937,71	648,554-1140,69	-	-
DR476	6	2381,67-6136,10	2381,67-6136,10	2381,67-6136,10	2381,67-6136,10	2381,67-3612,19	-	-
DR572	2	-	-	28,87-33,86	21,40-33,86	21,40-33,86	21,40-33,86	4,96-28,87
DR573	3	-	-	61,12 126,06-255,83	44,27-61,12 91,30-255,83	33,28-209,81	28,39-168,6	28,39-126,06
DR574	4	-	230,64-720,91	230,64-720,91	230,64-720,91	230,64-413,56	230,64-310,17	230,64
DR575	5	868,61-3432,03	868,61-3432,03	868,61-3432,03	868,61-3432,03	868,61-2078,15	868,61-1439,71	868,61-1041,5
DR576	6	3723,69-10146,8	3723,69-10146,8	3723,69-10146,8	3723,69-10146,8	3723,69-6144,09	3723,69-4255,64	-
DR672	2	-	-	-	-	23,36-26,11	23,36-26,11	6,61-7,45 11,96-26,11
DR673	3	-	-	-	-	124,53-221,47	124,53-221,47	34,02-197,01
DR674	4	-	236,65-675,51	236,65-675,51	236,65-675,51	236,65-424,33	236,65-318,25	236,65
DR675	5	747,1-3215,89	747,1-3215,89	747,1-3215,89	747,1-3215,89	747,1-2132,27	747,1-1476,89	747,1-1068,62
DR676	6	3820,66-9507,85	3820,66-9507,85	3820,66-9507,85	3820,66-9507,85	3820,66-6304,09	3820,66-4366,47	-
DR772	2	-	-	-	-	-	-	7,76-8,7 13,81-22,77
DR773	3	-	-	-	-	141,55-222,16	141,55-222,16	20,87 37,12-41,85 72,5-222,16
DR774	4	-	-	321,33-632,92	321,33-632,92	223,53-632,92	223,53-632,92	223,53-384,72
DR775	5	-	730,48-3691,20	730,48-3691,20	730,48-3691,20	730,48-3691,20	730,48-2523,53	730,48-874,52 1105,59-1323,71 1656,07-1982,78
DR776	6	-	3922,75-24963,27	3922,75-24963,27	3922,75-24963,27	3922,75-16981,28	3922,75-11986,79	3922,75-8913,25
DR872	2	-	-	-	-	-	-	-
DR873	3	-	-	-	-	-	-	61,27-128,20
DR874	4	-	-	-	-	139,7-602,03	139,7-602,03	139,7-532,59
DR875	5	-	744,27-2964,88	744,27-2964,88	744,27-2964,88	686,44-2964,88	686,44-1813,1	686,44-1424,58
DR876	6	-	3405,63-20051,26	3405,63-20051,26	3405,63-20051,26	3405,63-12200,68	3405,63-8612,25	3405,63-4005,78
DR972	2	-	-	-	-	-	-	-
DR973	3	-	-	-	-	-	-	-
DR974	4	-	-	-	-	197,95-523,19	197,95-523,19	197,95-523,19
DR975	5	-	-	938,19-2079,97	938,19-2079,97	603,97-2079,97	603,97-2079,97	474,03-2079,97
DR976	6	-	-	2909,37-20565,73	2909,37-20565,73	2909,37-11348,58	2909,37-8841,14	2909,37-5494,80

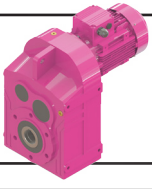

# Genel Bilgiler

## General Information

### Einführung



#### Motor Büyüklüğüne Göre Geometrik Mümkün Çevrim Oranları

Geometrically Possible Combinations of Ratios According to Motor Size  
Geometrisch mögliche Kombinationen von Übersetzungen nach Motorbaugröße

#### Motor Büyüklüğü / Motor Size / Motorbaugröße

Tip Type Typ	Kademe Stages Stufen	160	180	200	225	250	280	315
DR072	2	-	-	-	-	-	-	-
DR073	3	-	-	-	-	-	-	-
DR172	2	-	-	-	-	-	-	-
DR173	3	-	-	-	-	-	-	-
DR272	2	-	-	-	-	-	-	-
DR273	3	-	-	-	-	-	-	-
DR275	5	-	-	-	-	-	-	-
DR276	6	-	-	-	-	-	-	-
DR282	2	-	-	-	-	-	-	-
DR283	3	-	-	-	-	-	-	-
DR285	5	-	-	-	-	-	-	-
DR286	6	-	-	-	-	-	-	-
DR372	2	-	-	-	-	-	-	-
DR373	3	-	-	-	-	-	-	-
DR375	5	-	-	-	-	-	-	-
DR376	6	-	-	-	-	-	-	-
DR472	2	4,48-20,74	-	-	-	-	-	-
DR473	3	28,45-101,48	-	-	-	-	-	-
DR474	4	-	-	-	-	-	-	-
DR475	5	-	-	-	-	-	-	-
DR476	6	-	-	-	-	-	-	-
DR572	2	4,38-28,87	4,38-24,02	-	-	-	-	-
DR573	3	28,39-126,06	28,39-50,13 68,64-103,39	-	-	-	-	-
DR574	4	-	-	-	-	-	-	-
DR575	5	-	-	-	-	-	-	-
DR576	6	-	-	-	-	-	-	-
DR672	2	4,28-26,11	4,28-26,11	4,28-20,20	-	-	-	-
DR673	3	30,04-167,96	30,04-139,76	30,04-106,08	-	-	-	-
DR674	4	-	-	-	-	-	-	-
DR675	5	-	-	-	-	-	-	-
DR676	6	-	-	-	-	-	-	-
DR772	2	5,06-22,77	5,06-22,77	4,47-22,77	4,47-15,46	-	-	-
DR773	3	17,95-190,20	17,95-158,23	17,95-122,41	17,95-81,72	-	-	-
DR774	4	223,53-321,33	223,53-256,48	-	-	-	-	-
DR775	5	730,48 1105,6 1656,7	-	-	-	-	-	-
DR776	6	-	-	-	-	-	-	-
DR872	2	6,35-8,12 10,97-14,02	6,35-8,12 10,97-14,02	5,66-14,02	5,66-14,02	5,66-14,02	5,66-14,02	-
DR873	3	13,58-30,50 39,92-128,20	13,58-30,50 39,92-128,20	13,58-101,03	13,58-101,03	13,58-68,62	13,58-51,94	-
DR874	4	139,7-403,84	139,70-331,22	-	-	-	-	-
DR875	5	-	-	-	-	-	-	-
DR876	6	-	-	-	-	-	-	-
DR972	2	7,88-9,94 13,19-16,64	7,88-9,94 13,19-16,64	7,08-16,64	7,08-16,64	7,08-16,64	7,08-16,64	7,08-16,64
DR973	3	20,27-43,38 56,21-191,74	20,27-43,38 56,21-171,00	20,27-136,23	20,27-93,91	20,27-93,91	20,27-71,87	20,27-71,87
DR974	4	197,95-415,16	197,95-371,15	-	-	-	-	-
DR975	5	474,03-938,13	474,03-769,47	-	-	-	-	-
DR976	6	3079,47 4589,41	-	-	-	-	-	-

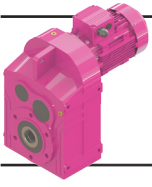

# Genel Bilgiler

## General Information

### Einführung



#### Servis Faktörü

Servis faktörü (fs) redüktörün çalıştığı şartlar ile uyumlu olması için gerekli olan emniyet katsayısıdır. "fs =1" Düzgün ve sakin yüklerde, günlük sekiz saat ve saatte yüz start çalışmayı karşılar.

Aşağıdaki etkenlere bağlıdır:

- Günlük çalışma süresi
- Yük sınıfı
- Bir saatteki start sayısı
- Redüktör tahrik tipi
- Diğer gözlemler

Bu etkenleri göz önüne aldığımızda, gerekli servis faktörünü belirlemek için:

1. Makinanın günlük çalışma süresini tespit ediniz.
2. Makinanın ne türde yükler verdiğini tespit ediniz (Sayfa 17-18).

- U - Düzgün ve sabit yükler
- M - Orta darbeli yükler
- H - Ağır darbeli yükler

Yük sınıfının daha teknik seçimi için rotora indirgenmiş toplam atalet momenti formülünden faydalanabilirsiniz (Sayfa 20).

3. Saatteki start sayısını tespit ediniz.
4. İlk üç maddeye bağlı servis faktörünü aşağıdaki tablodan seçiniz.

5. fs Redüktörümüzün tahrik tipine bağlı olarak "k" katsayısı ile çarpılarak artırılır.

- k=1 :Elektrik motoru veya hidromotor  
k=1.25 :İçten yanmalı çok silindirli motor  
k=1.5 :İçten yanmalı tek silindirli motor

#### Service Factor

Service Factor (fs) is a safety coefficient, which takes into account the different running conditions of the driven machine." fs=1" is used for uniform loads 8 hours working per day and up to 100 starts per hour.

Service factor depends on:

- Running time
- Nature of load
- Frequency of starting
- Driver type
- Other considerations

For the right selection of the needed service factor for your machine;

1. Determine the running time of driven machine.
2. Select the nature of load of driven machine (Page 17-18).

- U - Uniform loads
- M - Moderate loads
- H - Heavy shock loads

For a better selection, the nature of load can be calculated from the formulas given (page 20).

3. Determine frequency of starting
4. After determining the above mentioned factors, the service factor can be easily selected from the table given below.
5. The selected service factor must be multiplied with the factor "k" according to the driver type;

- k=1 :Electric motor or Hydrolicmotor  
k=1.25 :Multicylinder internal combustion engine  
k=1.5 :Single cylinder internal combustion engine

#### Betriebsfaktor

Der Betriebsfaktor (fs) ist ein Sicherheitsfaktor für die Getriebe, damit sie unter den Betriebsbedingungen sicher arbeiten. "fs =1" steht für gleichförmige Belastung, 8 Stunden pro Tag und bis zu 100 Schaltungen pro Stunde.

Betriebsfaktor ist abhängig von:

- Betriebsdauer
- Belastungsart
- Schalthäufigkeit
- Antriebsart
- Andere Faktoren

Um die richtigen Betriebsfaktor festzulegen;

1. Betriebsdauer der angetriebenen Maschine bestimmen.
2. Belastungsart der angetriebenen Maschine auswählen.

- U - Gleichförmige Belastung
- M - Ungleichförmige Belastung
- H - Stark Ungleichförmige Belastung

Um eine bessere Auswahl zu treffen, können die Belastungsarten mit den angegebenen Formeln (Seite 20) errechnet werden.

3. Schalthäufigkeit bestimmen.
4. Nach Bestimmen der oben angegebenen Werte, können die Betriebsfaktoren von der unten stehenden Tabelle entnommen werden.
5. Der ausgewählte Betriebsfaktor muß mit dem Faktor "k" abhängig von der Antriebsart multipliziert werden

- k=1 :Elektromotor oder Hydraulikmotor  
k=1.25 :Vielzylindermotor  
k=1.5 :Einzyliindermotor

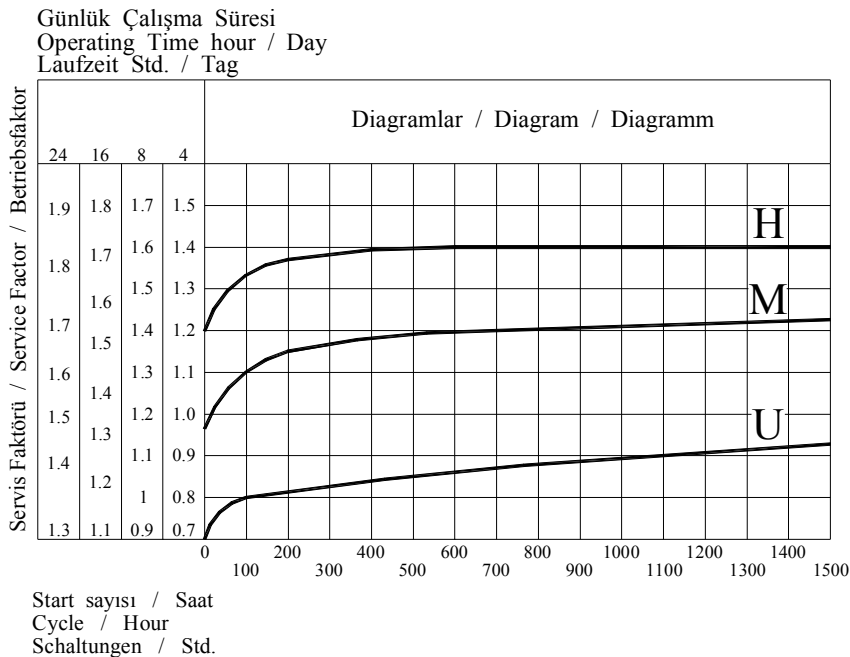

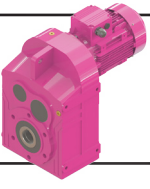

# Genel Bilgiler

## General Information

### Einführung



#### Yük Sınıflandırması

##### Krenler:

- U - Kaldırma Dişlileri
- Palanga Dişlileri
- M - Bomlu Vinç Dişlileri
- Yana Döndürme Dişlileri
- H - Yürütme Dişlileri

##### Pompalar:

- U - Santrifuj Pompalar (ince sıvı)
- M - Santrifuj Pompalar (yarı sıvı)
- H - Basınçlı Pompalar
- Dalgıç Pompalar

##### Taş ve Kil İşleme Makinaları:

- H - Çekiçli Değirmenler
- Döner Fırınlr
- Dövücü Değirmenler
- Kırıcılar
- Kürel Değirmenler
- Tuğla Presi
- Tüp Değirmenler

##### Tekstil Makinaları:

- M - Basma ve Boyama Makinaları
- Dokuma Tezgahları
- Hallac Makinaları
- Harman Makinaları
- Taneleme (Debegat )Tekneleri

##### Yağ Sanayi:

- M - Besleme Pompaları
- Döner Delme Teçizatları

##### Yiyecek Sanayi:

- M - Kutu Bıçaklar
- Kutu Kaplama
- Mayalama Tekneleri
- H - Kenar Açma

##### Çamaşır Yıkama Makinaları:

- M - Döner Kurutucular
- Yıkama Makinaları

##### Hadde Makinaları:

- M - Hız Ayarlı Silindirler
- Sabit Silindirler
- Sarma Makaraları
- Tel Çekme
- H - Çubuk Kesme Makinaları
- Döner Tablalar (büyük)
- Kabuk Sıyırma Makinaları
- Plaka Haddeleme
- Silindir Haddeleme
- Soğuk Haddeleme

#### Load Classification

##### Cranes:

- U - Hoist Gears
- Lifting Gears
- M - Defrocking jib Gears
- Slowing Gears
- H - Travelling Gears

##### Pumps:

- U - Centrifugal Pumps (light liquids)
- M - Centrifugal Pumps (semi liquid)
- H - Pressure Pumps
- Plunger Pumps

##### Stone and Clay Working Machines:

- H - Hammer Mills
- Rotary Kilns
- Beater Mills
- Breakers
- Ball Mills
- Brick Presses
- Tup Mills

##### Textile Machines:

- M - Printing and Dyeing Machines
- Looms
- Willow
- Batchers
- Tanning Vats

##### Oil Industry:

- M - Pipeline Pumps
- Rotary Drilling Equipment

##### Food Industry:

- M - Cane Knives
- Cane Crushers
- Mach Tubs
- H - Cane Mills

##### Laundries:

- M - Tumblers
- Washing Machines

##### Metal Rolling Mills:

- M - Roller Adjustment Drives
- Roller Straightened
- Winding Machines
- Wire Drawing Benches
- H - Billet Shears
- Rotary Tables (heavy)
- Descaling Machines,
- Sheet Mills
- Manipulators
- Cold Rolling Mills

#### Belastungsart

##### Krananlagen:

- U - Einziehwerke
- Hubwerke
- M - Schwenkwerke
- Wippwerke
- H - Fahrwerke

##### Pumpen:

- U - Kreiselpumpen (leichte Flüssigkeit)
- M - Kreiselpumpen (zähe Flüssigkeit)
- H - Prebpumpen
- Plungerpumpen

##### Steine und ErdenBearbeitendeMasch.

- H - Hammermühler
- Drehofen
- Schlagmühlen
- Brecher
- Kugelmühlen
- Ziegelpressen
- Rohrmühlen

##### Textilmaschinen:

- M - Drukerei
- Farbereimachinen
- Aufwickler
- Webstuhle
- Gerbfasser
- Reibwolfe

##### Erdölgewinnung:

- M - Pipeline Pumpen
- Rotative Bohranlagen

##### Nahrungsmittelmachinen:

- M - Rohrschneiden
- Knetmaschinen
- Maichen
- H - Rohrmühlen

##### Waschereimaschinen:

- M - Trommeltrockner
- Waschmaschinen

##### Wälzwerke:

- M - Rollenrichtmaschinen
- Walzenantriebe
- Drahtzuge
- Haspeln
- H - Blechscheren
- Rollgänge (schwer)
- Knüppelscheren
- Schöpfscheren
- Stranggubanlagen
- Kaltwälzwerke

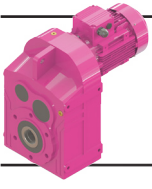

# Genel Bilgiler

## General Information

### Einführung



#### İnşaat Makinaları:

- M - Beton Mikserleri  
- Ağır Yük Asansörleri

#### Kağıt Makinaları:

- H - Islak Presler  
- Kağıt Hamur Makinaları  
- Kurutma Silindirleri  
- Perdahlama Silindirleri

#### Kauçuk Makinaları:

- M - Kalenderler  
- Mikserler  
H - Extruderler  
- Hamur Karma  
- Silindirler

#### Kimya Sanayi:

- M - Agidatörler (yarı sıvı)  
- Kurutma Merdaneleri  
- Mikserler ve Silindirleri

#### Konveyörler:

- M - Bant Ceppli Konveyörler  
- Çelik Bantlı Konveyörler  
- Dökme Yüklü Kayışlı Konv.  
H - Yük Asansörleri  
- Parça Yüklü Kayışlı Konv.

#### Building Machines:

- M - Concrete Mixers  
- Hoist

#### Paper Machines:

- H - Wet Presses  
- Pulpers  
- Drying Cylinders  
- Glazing Cylinders

#### Rubber Machinery:

- M - Calenders  
- Mixers  
H - Extruders  
- Pug Mills  
- Rolling Mills

#### Chemical Ind.:

- M - Aggidators (semi- liquid)  
- Drying Drums.  
- Mixers and Rolling Mills

#### Conveyors:

- M - Band Pocket Conveyors  
- Steel Belt Conveyors  
- Belt Conveyors  
H - Hoists  
- Bulk Belt Conveyors

#### Baumaschinen:

- M - Betonmischermaschinen  
- Bauaufzüge

#### Papiermaschinen:

- H - Naßpressen  
- Gautschen  
- Trockenzyylinder  
- Glattzyylinder

#### Kunststoffmaschinen:

- M - Kalender  
- Mischer  
H - Extruder  
- Knetwerke  
- Wälzwerke

#### Chemische Industrie:

- M - Rührwerke (leichte Flüssig.)  
- Trockentrommeln  
- Mischer und Wälzwerke

#### Förderanlagen:

- M - Gurtaschenbecherwerke  
- Stahlbandförderer  
- Gurtbandförderer (Schüttgut)  
H - Schrägaufzüge  
- Gurtbandförderer (Stückgut)

U	<b>Uniform Yük</b> Uniform Loads Gleichförmige Last	$F_i < 0,25$
M	<b>Orta Darbeli Yük</b> Moderate Loads Ungleichförmige Last	$F_i < 3$
H	<b>Darbeli Yük</b> Heavy Shock Loads Stark Ungleichförmige Last	$F_i < 10$

$$J'_{ext} = \frac{J_{ext}}{i^2}$$

$$F_i = \frac{J'_{ext}}{J_{rotor}}$$

$J_{ext}$  : **Motor miline indirgenmiş toplam dış atalet momenti**  
External moments of inertia reduced to the motor shaft  
Externe massenträgheitsmomente reduziert auf motorwelle

$i$  : **Tahvil oranı**  
Transmission ratio  
Übersetzung

$J_{rotor}$  : **Motorun atalet momenti**  
Moments of inertia to the motor  
Massenträgheitsmoment

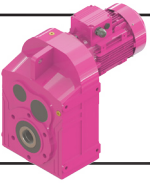

# Genel Bilgiler

## General Information

### Einführung



#### Redüktör Dönüş Yönleri

D Serisi ürünlerimiz için kullanılan yön tanımlaması aşağıdaki gibidir. Aşağıdaki tanımlama kilitli redüktörler için de geçerlidir.

#### Direction of Rotation

D Series direction of rotation of Yılmaz products are defined as follows. The definitions are also valid for gear units with backstop.

#### Getriebedrehrichtungen

Die Drehrichtungen für D Serie Getriebe sind wie folgt definiert. Die Definition ist auch bei Getrieben mit Rücklauf Sperre gültig.

	2-4-6 Kademe / 2-4-6 Stages / 2-4-6 Stufig	3-5 Kademe / 3-5 Stages / 3-5 Stufig
<b>Saat Yönünde</b> Clockwise im Uhrzeigersinn <b>CW</b>		
<b>Saat Tersi Yönünde</b> Counter Clockwise gegen Uhrzeigersinn <b>CCW</b>		

Giriş mili dönüş yönüne göre çıkış mili dönüş yönleri aşağıdaki gibidir.

Output shaft rotation directions according to the input shaft rotation directions are as follows.

Drehrichtungen der Abtriebswelle im Abhängigkeit von der Antriebswellen sind wie folgt;

2-4-6 Kademe / 2-4-6 Stages / 2-4-6 Stufig	3-5 kademe / 3-5 Stages / 3-5 Stufig

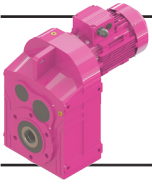

# Genel Bilgiler

## General Information

### Einführung



### Radyal Yükler

Çıkış miline gelebilecek radyal yükler yatak ömrüne göre belirlenmiş ve tablolar halinde verilmiştir. Bu tablolarda verilen  $F_{qam}$  güvenilir radyal yükü  $f_s=1$  şartı ve yükün mil ortasını yüklediği durum için verilmiştir. Darbeli yüklerin olması durumunda daha önce verilmiş olan servis faktörü tablosundaki değerler dikkate alınmalıdır. Güvenilir aksiyal yük ( $F_{qam}$  veya  $F_{qem}$ ) verilen güvenilir radyal yükün ( $F_{qama}$  veya  $F_{qema}$ ) %25'i kadar alınır. Verilen radyal ve eksenel yükler kuvvetin en kötü açı şartında etki ettiği durum için verilmiştir. Mil ortasına gelen kuvvetin açısına göre daha yüksek radyal yükler mümkündür (Firmamıza danışınız). Bağlantı şekline göre oluşan radyal yük  $F_q$  sayfa 23 de verilen formüller yardımı ile hesaplanır.

Redüktör seçiminde ;

$$\begin{aligned} F_{qa} &\leq F_{qam} \\ F_{qe} &\leq F_{qem} \end{aligned}$$

şartı göz önünde tutulmalı. Eğer etkiyen radyal kuvvet milin orta noktasında değil ise verilen güvenilir değerin aşağıda verilen formül ile düzeltilmesi gerekir.

$$F_{qam}' = F_{qam} \frac{t}{y+u}$$

$$F_{qem}' = F_{qem} \frac{t}{y+u}$$

"t", "y" Değerleri aşağıda verilmiştir. "u" Değeri görüldüğü gibi kuvvetin uygulama noktasıdır.

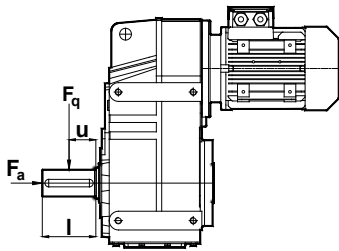

### Overhung Loads

The permissible overhung loads are calculated by considering working life and is listed on the tables. The given permissible overhung loads  $F_{qam}$  are based on  $f_s=1$  and are valid for forces which are applied to the midpoint of the shaft. For shock loading applications the service factor given on the table must take into consideration. The permissible axial load ( $F_{qama}$  or  $F_{qema}$ ) is %25 x ( $F_{qam}$  or  $F_{qem}$ ). The listed permissible overhung loads are based on the worst loading direction. Higher overhung loads can be applied for different loading directions (Please ask if requested). The effective overhung load at the gear box shaft  $F_q$  will be determined with the given formulas on page 23.

In Selection ;

$$\begin{aligned} F_{qa} &\leq F_{qam} \\ F_{qe} &\leq F_{qem} \end{aligned}$$

these formulas must be taken into consideration. If the load is not applied at the midpoint of the shaft; the given permissible load must be corrected with the following formulas.

$$F_{qam}' = F_{qam} \frac{t}{y+u}$$

$$F_{qem}' = F_{qem} \frac{t}{y+u}$$

The values "t", "y" can be taken from the below table. The value "u" is the length of the application point as shown below.

### Querkräfte

Die in den nachfolgenden Tabellen angegebenen zulässigen Radialbelastungen  $F_{qam}$  gelten bei Kraftangriff auf die Mitte Wellenendes. Den Angaben liegt der Betriebsfaktor  $f_s=1$  zu Grunde. Bei stoßartigen Belastungsfällen ist auch hier der entsprechende Betriebsfaktor zu berücksichtigen. Zulässige Axialkräfte  $F_{qama}$  oder  $F_{qema}$  können ohne weitere Nachrechnung bis zu einer Höhe von ca. 25% der zulässigen Radialbelastung  $F_{qam}$  oder  $F_{qem}$  aufgenommen werden. Bei der Ermittlung der zulässige Querkräfte sind höhere Werte möglich (Bitte Rückfragen). Die auftretende Querkräfte  $F_q$  ab der Getriebewelle wird wie in der nachfolgenden Formel bestimmt.

Bei dieser Auswahl;

$$\begin{aligned} F_{qa} &\leq F_{qam} \\ F_{qe} &\leq F_{qem} \end{aligned}$$

müssen die oben angegebenen Bedingungen berücksichtigt werden. Ist der Kraftangriff nicht auf Wellenmitte, so kann die zulässige Querkräfte mit Hilfe der unten stehenden Formel auf jede beliebige Stelle umgerechnet werden.

$$F_{qam}' = F_{qam} \frac{t}{y+u}$$

$$F_{qem}' = F_{qem} \frac{t}{y+u}$$

Die Werte "t" und "y" sind in den nachfolgenden Tabellen angegeben. Der Wert "u" ist die Stelle des Kraftangriffs wie auf der nächsten Seite angegeben.

DR...01											
Çıkış Milinde radyal kuvvet hesabı düzeltme katsayıları											
Overhung Load correcting values on output shaft											
Querkräfte auf Ausgangswelle Korrigierungszahlen											
Tip Type	DR072	DR172	DR272-3	DR282-3	DR372-3	DR472-3	DR572-3	DR672-3	DR772-3	DR872-3	DR972-3
Typ	DR073	DR173	DR275-6	DR285-6	DR374-5	DR474-5	DR574-5	DR674-5	DR774-5	DR874-5	DR974-5
t	116,5	133,5	166	183	198,5	238,5	277,5	344	407,5	485	556
y	91,5	103,5	136	143	158,5	188,5	217,5	274	322,5	380	451
l	50	60	60	80	80	100	120	140	170	210	210

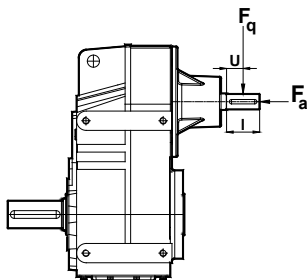

DT...01									
Giriş Milinde radyal kuvvet hesabı düzeltme katsayıları									
Overhung load correcting values on input shaft									
Querkräfte auf Eingangswelle korrigierungszahlen									
Tip Type	DT072-3	DT172-3	DT272-3-5	DT282-3	DT472-3	DT572-3	DT672-3	DT772-3	DT872-3
Typ	DT285-6	DT375-6	DT475-6	DT474	DT574	DT774	DT874	DT974	DT972-3
t	78	111,5	126	137	215,5	179,5	220,5	261,5	
y	58	86,5	96	102	160,5	129,5	165,5	206,5	
l	40	50	60	70	110	100	110	110	

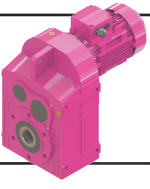

# Genel Bilgiler

## General Information

### Einführung

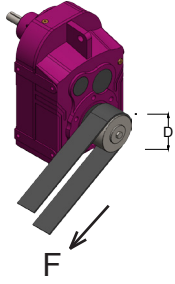

#### Radyal Yüklerin Hesabı

Radyal Yük  $F_q(N)$ 'nin hesaplanmasında, gerekli tahrik momenti  $M (Nm)$ , kasnak veya dişli çapı  $D(mm)$  olmak üzere aşağıdaki formüller kullanılır.

#### Calc. Of Overhung Loads

Radial Load  $F_q(N)$  is calculated with the following equations where required moment  $M (Nm)$  and hoop or gear diameter  $D (mm)$  is used.

#### Berechnung der Querkräfte

Der Fall der radialen Belastung  $F_q(N)$  kann mit den angegebenen Gleichungen berechnet werden. Antriebsmoment  $M (Nm)$  und Zahnrad- oder Riemenscheiben Durchmesser  $D (mm)$ .

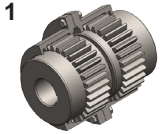

#### 1. Elastik Kaplin

Çalışma sırasında oluşan sapmalar kaplinin güvenlik sınırları içinde ise kuvvetler ihmal edilebilir.

#### 1. Elastic Coupling

If Elastic Coupling is working in its reliable working area, the overhung loads can be neglected.

#### 1. Elastische Kupplung

Wenn die elastische Kupplung in ihren zulässige Arbeits toleranz arbeitet, können die radialen Belastungen vernachlässigt werden.

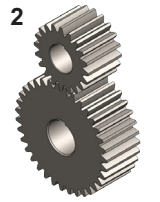

#### 2. Düz Dişli

(20° kavrama açılı)

$$F_q = \frac{2100 \times M_2}{D}$$

#### 2. For Spur Gear

(Pressure angle 20°)

$$F_q = \frac{2100 \times M_2}{D}$$

#### 2. Stirnradgetriebe

(Angriffswinkel=20°)

$$F_q = \frac{2100 \times M_2}{D}$$



#### 3. Küçük Hızlarda Zincir Dişli (z>17)

$$F_q = \frac{2100 \times M_2}{D}$$

#### 3. For Chain Drive With Low Speed (z>17)

$$F_q = \frac{2100 \times M_2}{D}$$

#### 3. Kettantrieb mit niedriger Geschwindigkeit (z>17)

$$F_q = \frac{2100 \times M_2}{D}$$

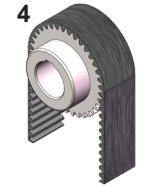

#### 4. Triger Kayış

$$F_q = \frac{2500 \times M_2}{D}$$

#### 4. For Trigger Belt

$$F_q = \frac{2500 \times M_2}{D}$$

#### 4. Zahnriemenantrieb

$$F_q = \frac{2500 \times M_2}{D}$$



#### 5. V Kayış

$$F_q = \frac{5000 \times M_2}{D}$$

#### 5. For V Belt

$$F_q = \frac{5000 \times M_2}{D}$$

#### 5. Keilriemenantrieb

$$F_q = \frac{5000 \times M_2}{D}$$



#### 6. Gerdirme Makaralı Kayış

$$F_q = \frac{5000 \times M_2}{D}$$

#### 6. Flat Belt With Spanning Pulley

$$F_q = \frac{5000 \times M_2}{D}$$

#### 6. Flachriemenantrieb mit Spannungstrommel

$$F_q = \frac{5000 \times M_2}{D}$$

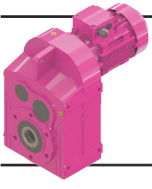

# Genel Bilgiler

## General Information

### Einführung



### Ekstruder Tiplerde Müsade Edilebilir Eksenal Yükler

Permissible Axial Loads for Extruder Types  
Zulässige Axialkräfte für Extruder Typ Getriebe

DRE172-173				
$n_2$	$F_{ama}$ [kN]			
	Ömür / Lifetime / Lebensdauer Lh [saat] / [hour] / [Stunde]			
	40000	20000	10000	5000
20	14.6	18.0	22.2	27.3
30	13.0	16.0	19.6	24.2
40	11.9	14.6	18.0	22.2
50	11.1	13.7	16.9	20.8
65	10.3	12.6	15.6	19.2
80	9.7	11.9	14.6	18.0
100	9.0	11.1	13.7	16.9
120	8.5	10.5	13.0	16.0
140	8.2	10.0	12.4	15.2
160	7.8	9.7	11.9	14.6
180	7.6	9.3	11.5	14.1
200	7.3	9.0	11.1	13.7
220	7.1	8.8	10.8	13.3
240	6.9	8.5	10.5	13.0
260	6.8	8.3	10.3	12.6
280	6.6	8.2	10.0	12.4
300	6.5	8.0	9.8	12.1
320	6.4	7.8	9.7	11.9

DRE272-273				
$n_2$	$F_{ama}$ [kN]			
	Ömür / Lifetime / Lebensdauer Lh [saat] / [hour] / [Stunde]			
	40000	20000	10000	5000
20	27.0	33.3	41.0	50.5
30	23.9	29.5	36.3	44.7
40	22.0	27.0	33.3	41.0
50	20.5	25.3	31.1	38.4
65	19.0	23.4	28.8	35.5
80	17.8	22.0	27.0	33.3
100	16.7	20.5	25.3	31.1
120	15.8	19.4	23.9	29.5
140	15.1	18.6	22.9	28.2
160	14.5	17.8	22.0	27.0
180	14.0	17.2	21.2	26.1
200	13.5	16.7	20.5	25.3
220	13.2	16.2	20.0	24.6
240	12.8	15.8	19.4	23.9
260	12.5	15.4	19.0	23.4
280	12.2	15.1	18.6	22.9
300	12.0	14.8	18.2	22.4
320	11.8	14.5	17.8	22.0

DRE282-283				
$n_2$	$F_{ama}$ [kN]			
	Ömür / Lifetime / Lebensdauer Lh [saat] / [hour] / [Stunde]			
	40000	20000	10000	5000
20	104.8	129.0	158.8	195.6
30	92.7	114.2	140.6	173.2
40	85.1	104.8	129.0	158.8
50	79.6	98.0	120.6	148.5
65	73.5	90.5	111.5	137.3
80	69.1	85.1	104.8	129.0
100	64.6	79.6	98.0	120.6
120	61.2	75.3	92.7	114.2
140	58.4	71.9	88.5	109.0
160	56.1	69.1	85.1	104.8
180	54.2	66.7	82.1	101.1
200	52.5	64.6	79.6	98.0
220	51.0	62.8	77.3	95.2
240	49.7	61.2	75.3	92.7
260	48.5	59.7	73.5	90.5
280	47.4	58.4	71.9	88.5
300	46.5	57.2	70.4	86.7
320	45.6	56.1	69.1	85.1

$n_2$  : Çıkış Devri [d/dak] / Output Speed [rpm] / Abtriebsdrehzahl [U/min]

DRE372-373				
$n_2$	$F_{ama}$ [kN]			
	Ömür / Lifetime / Lebensdauer Lh [saat] / [hour] / [Stunde]			
	40000	20000	10000	5000
20	104.8	129.0	158.8	195.6
30	92.7	114.2	140.6	173.2
40	85.1	104.8	129.0	158.8
50	79.6	98.0	120.6	148.5
65	73.5	90.5	111.5	137.3
80	69.1	85.1	104.8	129.0
100	64.6	79.6	98.0	120.6
120	61.2	75.3	92.7	114.2
140	58.4	71.9	88.5	109.0
160	56.1	69.1	85.1	104.8
180	54.2	66.7	82.1	101.1
200	52.5	64.6	79.6	98.0
220	51.0	62.8	77.3	95.2
240	49.7	61.2	75.3	92.7
260	48.5	59.7	73.5	90.5
280	47.4	58.4	71.9	88.5
300	46.5	57.2	70.4	86.7
320	45.6	56.1	69.1	85.1

DRE472-473				
$n_2$	$F_{ama}$ [kN]			
	Ömür / Lifetime / Lebensdauer Lh [saat] / [hour] / [Stunde]			
	40000	20000	10000	5000
20	134.5	165.6	203.9	251.1
30	119.0	146.6	180.5	222.3
40	109.2	134.5	165.6	203.9
50	102.1	125.7	154.8	190.7
65	94.4	116.2	143.1	176.2
80	88.7	109.2	134.5	165.6
100	82.9	102.1	125.7	154.8
120	78.5	96.7	119.0	146.6
140	75.0	92.3	113.7	140.0
160	72.0	88.7	109.2	134.5
180	69.5	85.6	105.4	129.8
200	67.3	82.9	102.1	125.7
220	65.4	80.6	99.2	122.2
240	63.8	78.5	96.7	119.0
260	62.2	76.6	94.4	116.2
280	60.9	75.0	92.3	113.7
300	59.6	73.4	90.4	111.3
320	58.5	72.0	88.7	109.2

DRE572-573				
$n_2$	$F_{ama}$ [kN]			
	Ömür / Lifetime / Lebensdauer Lh [saat] / [hour] / [Stunde]			
	40000	20000	10000	5000
20	172.0	211.8	260.8	321.1
30	152.3	187.5	230.9	284.3
40	139.7	172.0	211.8	260.8
50	130.6	160.8	198.1	243.9
65	120.7	148.7	183.0	225.4
80	113.4	139.7	172.0	211.8
100	106.1	130.6	160.8	198.1
120	100.4	123.7	152.3	187.5
140	95.9	118.1	145.4	179.0
160	92.1	113.4	139.7	172.0
180	88.9	109.5	134.8	166.0
200	86.1	106.1	130.6	160.8
220	83.7	103.1	126.9	156.3
240	81.5	100.4	123.7	152.3
260	79.6	98.0	120.7	148.7
280	77.9	95.9	118.1	145.4
300	76.3	93.9	115.6	142.4
320	74.8	92.1	113.4	139.7

$n_2$  : Çıkış Devri [d/dak] / Output Speed [rpm] / Abtriebsdrehzahl [U/min]

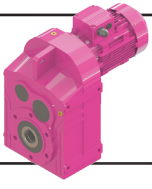

# Genel Bilgiler

## General Information

### Einführung



### Ekstruder Tiplerde Müsade Edilebilir Eksnel Yükler

Permissible Axial Loads for Extruder Types  
Zulässige Axialkräfte für Extruder Typ Getrieben

DRE672-673				
n <sub>2</sub>	F <sub>ama</sub> [kN]			
	Ömür / Lifetime / Lebensdauer Lh [saat] / [hour] / [Stunde]			
	40000	20000	10000	5000
20	209.5	258.0	317.7	391.2
30	185.5	228.4	281.3	346.4
40	170.1	209.5	258.0	317.7
50	159.1	195.9	241.3	297.1
65	147.1	181.1	223.0	274.6
80	138.2	170.1	209.5	258.0
100	129.2	159.1	195.9	241.3
120	122.3	150.6	185.5	228.4
140	116.8	143.8	177.1	218.1
160	112.2	138.2	170.1	209.5
180	108.3	133.4	164.2	202.2
200	104.9	129.2	159.1	195.9
220	102.0	125.6	154.6	190.4
240	99.3	122.3	150.6	185.5
260	97.0	119.4	147.1	181.1
280	94.8	116.8	143.8	177.1
300	92.9	114.4	140.9	173.5
320	91.1	112.2	138.2	170.1

DRE772-773				
n <sub>2</sub>	F <sub>ama</sub> [kN]			
	Ömür / Lifetime / Lebensdauer Lh [saat] / [hour] / [Stunde]			
	40000	20000	10000	5000
20	350.2	431.3	531.1	653.9
30	310.1	381.8	470.2	579.0
40	284.4	350.2	431.3	531.1
50	266.0	327.5	403.3	496.6
65	245.8	302.7	372.8	459.0
80	231.0	284.4	350.2	431.3
100	216.0	266.0	327.5	403.3
120	204.5	251.8	310.1	381.8
140	195.2	240.4	296.0	364.5
160	187.6	231.0	284.4	350.2
180	181.0	222.9	274.5	338.0
200	175.4	216.0	266.0	327.5
220	170.5	209.9	258.5	318.3
240	166.1	204.5	251.8	310.1
260	162.1	199.6	245.8	302.7
280	158.5	195.2	240.4	296.0
300	155.3	191.2	235.5	290.0
320	152.3	187.6	231.0	284.4

DRE872-873				
n <sub>2</sub>	F <sub>ama</sub> [kN]			
	Ömür / Lifetime / Lebensdauer Lh [saat] / [hour] / [Stunde]			
	40000	20000	10000	5000
20	403.4	496.7	611.7	753.2
30	357.1	439.8	541.5	666.9
40	327.6	403.4	496.7	611.7
50	306.3	377.2	464.5	572.0
65	283.1	348.7	429.3	528.7
80	266.0	327.6	403.4	496.7
100	248.8	306.3	377.2	464.5
120	235.5	290.0	357.1	439.8
140	224.9	276.9	341.0	419.9
160	216.0	266.0	327.6	403.4
180	208.5	256.8	316.2	389.4
200	202.0	248.8	306.3	377.2
220	196.3	241.8	297.7	366.6
240	191.3	235.5	290.0	357.1
260	186.7	229.9	283.1	348.7
280	182.6	224.9	276.9	341.0
300	178.9	220.3	271.2	334.0
320	175.4	216.0	266.0	327.6

n<sub>2</sub> : Çıkış Devri [d/dak] / Output Speed [rpm] / Abtriebsdrehzahl [U/min]

DRE972-973				
n <sub>2</sub>	F <sub>ama</sub> [kN]			
	Ömür / Lifetime / Lebensdauer Lh [saat] / [hour] / [Stunde]			
	40000	20000	10000	5000
20	456.5	562.2	692.3	852.5
30	404.2	497.7	612.9	754.7
40	370.7	456.5	562.2	692.3
50	346.7	426.9	525.7	647.4
65	320.4	394.6	485.9	598.3
80	301.1	370.7	456.5	562.2
100	281.6	346.7	426.9	525.7
120	266.6	328.2	404.2	497.7
140	254.5	313.4	385.9	475.2
160	244.5	301.1	370.7	456.5
180	236.0	290.6	357.9	440.7
200	228.7	281.6	346.7	426.9
220	222.2	273.6	336.9	414.9
240	216.5	266.6	328.2	404.2
260	211.3	260.2	320.4	394.6
280	206.7	254.5	313.4	385.9
300	202.4	249.3	307.0	378.0
320	198.6	244.5	301.1	370.7

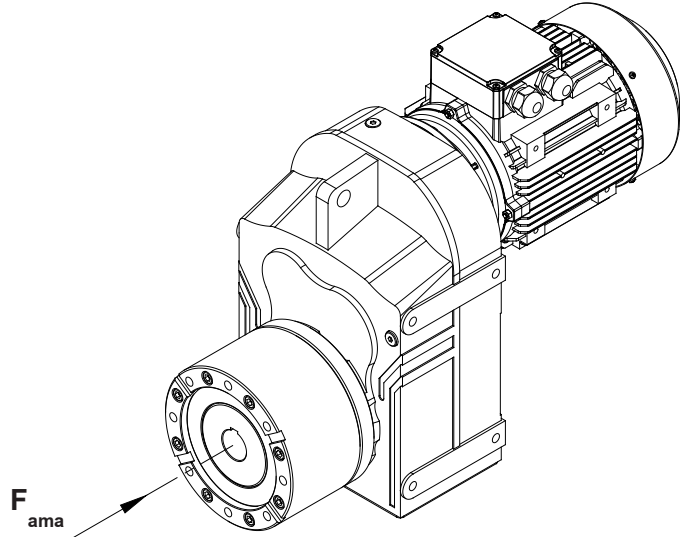

n<sub>2</sub> : Çıkış Devri [d/dak] / Output Speed [rpm] / Abtriebsdrehzahl [U/min]



# Genel Bilgiler

## General Information

### Einführung



#### Eşdeğer Güç Hesabı

Sabit devirde, ancak değişken momentlerde (güçlerde) çalışan redüktörler için eşdeğer tork altındaki, eşdeğer güç hesaplanabilir. Bu eşdeğer güç kullanılarak bilinen sabit güçteki redüktör seçim yöntemi kullanılarak seçim yapılabilir. Burada ağırlıklı torka göre eşdeğer anma torku belirlenmektedir. Hesaplanan bu güçte çalışan redüktör, teorik olarak, değişken yüklerde çalışan redüktör ile aynı emniyet değerine ve ömre sahiptir.

Bir çevrim boyunca oluşan değişken torklar, en yüksek torktan, en düşüğe doğru yatay zaman eksenini boyunca sıralanır (bakınız alttaki şekil). Bu şekile göre eşdeğer tork şu formül ile hesaplanır;

$$T_e = \left( \frac{\Delta t_1 \times T_1^{6.6} + \dots + \Delta t_n \times T_n^{6.6}}{t} \right)^{\frac{1}{6.6}}$$

Eğer  $T_n$  değerleri (en düşük tork),  $T_e$ 'nin 0,5 katının altında ise, bu tork dilimi yok sayılarak, işlem tekrarlanır;

Eğer  $T_n < T_e \times 0.5$  ise

$$T_e = \left( \frac{\Delta t_1 \times T_1^{6.6} + \dots + \Delta t_{n-1} \times T_{n-1}^{6.6}}{t - \Delta t_n} \right)^{\frac{1}{6.6}}$$

Tüm  $T_n$  değerleri  $T_e$ 'nin 0,5 katının üzerinde ise, eşdeğer güç aşağıdaki gibi hesaplanır;

$$P_{eq} = P_N = \frac{T_e \times n}{9550}$$

Eşdeğer gücün bulunmasından sonra eşdeğer güç değeri kullanılarak, bu katalogta verilen redüktör seçimi bölümünde anlatılan adımlar uygulanarak redüktör seçimi tamamlanır.

#### Equivalent Power Rating Calculation

The equivalent power by an equivalent constant torque can be calculated for gearboxes working in constant speed but variable torques (or powers). Using this equivalent power it is possible to make a gearbox selection according to the usual gearbox selection method with constant torques. The equivalent torque will be determined according to the mean of dominating torques. The gearbox working in constant equivalent torque will theoretically have the same lifetime and safety compared to the variable torque one.

To calculate the equivalent torques, the variable torques in a cycle must be sorted from the maximal to the minimal on a horizontal time line (Check the graphic below). According to the graphic below the equivalent torque can be calculated with the following formula;

$$T_e = \left( \frac{\Delta t_1 \times T_1^{6.6} + \dots + \Delta t_n \times T_n^{6.6}}{t} \right)^{\frac{1}{6.6}}$$

If  $T_n$  (the lowest torque) is lower than 50% of  $T_e$ , this torque part must be taken out of the torque graph and the calculation must be repeated;

If  $T_n < T_e \times 0.5$  then

$$T_e = \left( \frac{\Delta t_1 \times T_1^{6.6} + \dots + \Delta t_{n-1} \times T_{n-1}^{6.6}}{t - \Delta t_n} \right)^{\frac{1}{6.6}}$$

If all  $T_n$  values are higher than 50% of  $T_e$  then the equivalent power can be calculated by the following formula;

$$P_{eq} = P_N = \frac{T_e \times n}{9550}$$

After the equivalent power is determined the selection of gearbox is made according to the selection procedures given on the gearbox selection part in this catalogue.

#### Berechnung Äquivalenter Leistung

Die äquivalente Leistung bei äquivalenten Drehmoment kann für Getrieben mit konstanten Drehzahl und variablen Momente berechnet werden. Mit dieser Leistung kann das Getriebe ausgelegt werden, wie bei konstanten Leistung. Man bestimmt hiermit also die maßgebende Belastung. Das ausgelegte Getriebe erreicht theoretisch dem gleichen Lebensdauer und hat die gleiche Sicherheit.

Für die Berechnung der äquivalenten Drehmoment müssen die einzelnen Drehmomentanteile auf eine Zeitachse von größten bis zu kleinsten angeordnet werden (siehe unteres Bild). Das äquivalente Drehmoment wird nach folgender Formel berechnet;

$$T_e = \left( \frac{\Delta t_1 \times T_1^{6.6} + \dots + \Delta t_n \times T_n^{6.6}}{t} \right)^{\frac{1}{6.6}}$$

Wenn  $T_n$  (niedrigstes Drehmoment) kleiner als 50% von  $T_e$  ist, muss dieser Anteil vernachlässigt werden und die Berechnung soll neu durchgeführt werden;

Wenn  $T_n < T_e \times 0.5$  dann

$$T_e = \left( \frac{\Delta t_1 \times T_1^{6.6} + \dots + \Delta t_{n-1} \times T_{n-1}^{6.6}}{t - \Delta t_n} \right)^{\frac{1}{6.6}}$$

Wenn alle  $T_n$  Werte höher als 50% von  $T_e$  sind, dann wird die äquivalente Leistung nach folgender Formel berechnet;

$$P_{eq} = P_N = \frac{T_e \times n}{9550}$$

Nach Bestimmung der äquivalenter Leistung, erfolgt die Getriebeauslegung wie bei konstanter Leistung. Die Auswahlverfahren für konstante Leistung ist in diesem Katalog angegeben.

(Moment / Torque / Moment)

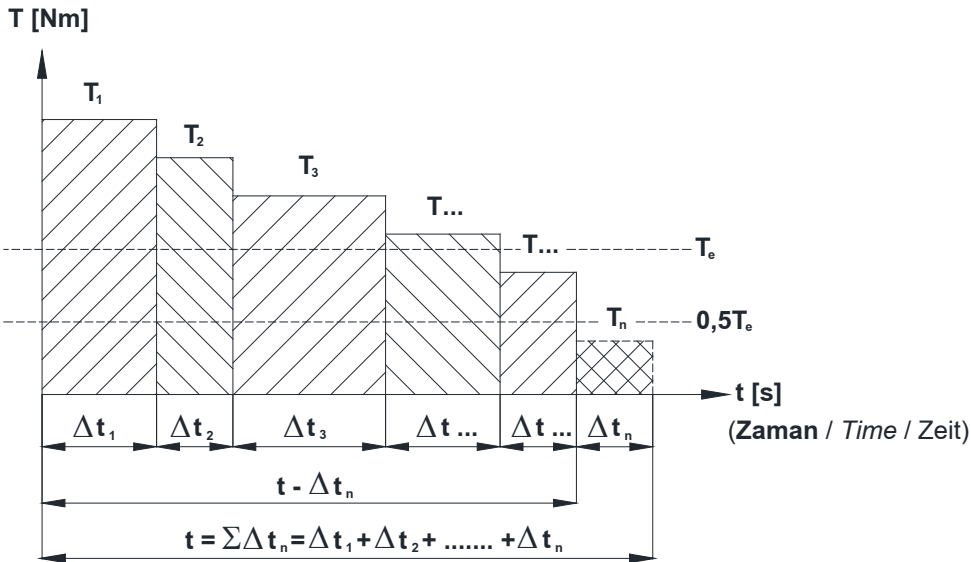

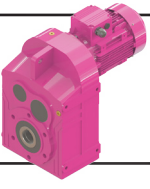

# Genel Bilgiler

## General Information

### Einführung



#### Eşdeğer Güç Hesabı Örneği

Çift yönlü çalışan ham demir haddesi için aşağıdaki çalışma koşulları belirlenmiş;

##### Veriler:

Toplam bir iş çevrimi: 2 dak.

1. Yük kademesi: 48 kNm, 30 sn

2. Yük Kademesi: 32 kNm, 22 sn

3. Yük Kademesi: 28 kNm, 15 sn

4. Yük Kademesi: 16 kNm, 10 sn

5. Yük Kademesi: 5 kNm, 43sn

Makina sabit devri: 50 d/dak

Redüktör seçimine esas olacak eşdeğer yük aranmaktadır.

##### Çözüm:

Bir çevrimin toplam zamanı;

$$t = t_1 + t_2 + t_3 + t_4 + t_5 = 120 \text{ sn}$$

Eşdeğer Tork;

$$T_e = \left( \frac{30 \times 48^{6,6} + \dots + 43 \times 5^{6,6}}{120} \right)^{\frac{1}{6,6}}$$

$$= 39,2 \text{ kNm}$$

%50 eşdeğer tork;

$$0,5 \times T_e = 19,6 \text{ kNm}$$

Her bir tork dilimi bu değer üzerinde olmalı

$$T_{4,5} < 0,5 \times T_e$$

%50 torkun altındakileri çıkararak hesabı tekrarlayalım;

$$t' = t_1 - t_4 - t_5 = 120 - 43 - 10 = 67 \text{ s}$$

$$T_e = \left( \frac{30 \times 48^{6,6} + 22 \times 32^{6,6} + 15 \times 28^{6,6}}{67} \right)^{\frac{1}{6,6}}$$

$$= 42,9 \text{ kNm}$$

Moment ve devir değerlerini kullanarak eşdeğer gücümüzü hesaplayalım;

$$P_{eq} = \frac{T_e \times n}{9550} = \frac{42,9 \times 1000 \times 50}{9550} = 225 \text{ kW}$$

Yukarıdaki güç ve devir değeri kullanılarak bu katalogta anlatılan seçim prosedürü ile redüktör seçimi yapılabilir.

#### Equivalent Power Rating Sample

The following data is given for a reversing blooming mill;

##### Torque steps:

Total one cycle time: 2 min.

1st torque part: 48 kNm, 30 s

2nd torque part: 32 kNm, 22 s

3th torque part: 28 kNm, 15 s

4th torque part: 16 kNm, 10 s

5th torque part: 5 kNm, 43 s

Machine constant speed: 50 rpm

The equivalent power, which is required for gear unit selection, is to determine.

##### Solution:

Total time in a cycle;

$$t = t_1 + t_2 + t_3 + t_4 + t_5 = 120 \text{ sn}$$

Equivalent Torque;

$$T_e = \left( \frac{30 \times 48^{6,6} + \dots + 43 \times 5^{6,6}}{120} \right)^{\frac{1}{6,6}}$$

$$= 39,2 \text{ kNm}$$

50% of Equivalent torque;

$$0,5 \times T_e = 19,6 \text{ kNm}$$

Every torque part must be lower then this value;

$$T_{4,5} < 0,5 \times T_e$$

We are repeating the calculation by taking out the torque parts, which are below 50%;

$$t' = t_1 - t_4 - t_5 = 120 - 43 - 10 = 67 \text{ s}$$

$$T_e = \left( \frac{30 \times 48^{6,6} + 22 \times 32^{6,6} + 15 \times 28^{6,6}}{67} \right)^{\frac{1}{6,6}}$$

$$= 42,9 \text{ kNm}$$

By using the equivalent torque and constant speed we calculate the equivalent power;

$$P_{eq} = \frac{T_e \times n}{9550} = \frac{42,9 \times 1000 \times 50}{9550} = 225 \text{ kW}$$

Now by using the above calculated equivalent power and constant speed we camake the gear-box selection with the procedures described in this catalogue.

#### Beispiel für Äquivalente Leistung

Die nachfolgenden Angaben sind für eine Blechreversierwalze;

##### Drehmoment stufen:

Gesamte Zeit für einem Arbeitszyklus: 2 min.

Drehmomentanteil 1: 48 kNm 30 s

Drehmomentanteil 2: 32 kNm 22 s

Drehmomentanteil 3: 28 kNm 15 s

Drehmomentanteil 4: 16 kNm 10 s

Drehmomentanteil 5: 5 kNm 43 s

Maschine hat konstante Drehzahl: 50 U/min

Gesucht ist die äquivalente Leistung, die für die Getriebeauslegung nötig ist.

##### Lösung:

Gesamte Zeit für einem Arbeitszyklus;

$$t = t_1 + t_2 + t_3 + t_4 + t_5 = 120 \text{ sn}$$

Äquivalentes Drehmoment;

$$T_e = \left( \frac{30 \times 48^{6,6} + \dots + 43 \times 5^{6,6}}{120} \right)^{\frac{1}{6,6}}$$

$$= 39,2 \text{ kNm}$$

50% von äquivalenten Drehmoment;

$$0,5 \times T_e = 19,6 \text{ kNm}$$

Drehmomentanteile müssen größer als dieser Wert sein;

$$T_{4,5} < 0,5 \times T_e$$

Wir wiederholen die Berechnung nochmals ohne die kleine Drehmomentanteile;

$$t' = t_1 - t_4 - t_5 = 120 - 43 - 10 = 67 \text{ s}$$

$$T_e = \left( \frac{30 \times 48^{6,6} + 22 \times 32^{6,6} + 15 \times 28^{6,6}}{67} \right)^{\frac{1}{6,6}}$$

$$= 42,9 \text{ kNm}$$

Mit Hilfe von äquivalenten Drehmoment und konstanter Drehzahl berechnet man die äquivalente Leistung;

$$P_{eq} = \frac{T_e \times n}{9550} = \frac{42,9 \times 1000 \times 50}{9550} = 225 \text{ kW}$$

Nach Bestimmung der äquivalente Leistung und konstanter Drehzahl, erfolgt die Getriebeauslegung dann wie die Getriebeauswahl gemäß dem in diesem Katalog beschriebenen Verfahren für konstante Leistung.

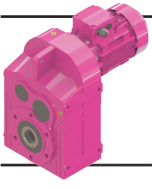

# Genel Bilgiler

## General Information

### Einführung



#### Redüktör Seçimi

Bir redüktör seçiminde aşağıdaki yol izlenmelidir.

1. Çalışma şartlarına bağlı olarak servis faktörünü (fs) belirleyiniz. (Servis Faktörü Sayfa 16).

2. Makinanız için gerekli olan momenti belirleyiniz  $M_2$  (redüktör gerekli çıkış momenti ).

3. Makinanızın devrini belirleyiniz  $n_2$  (redüktör gerekli çıkış devri ).

4. Makinanızın güç ihtiyacını (Redüktör çıkış gücünü) " $P_2$ " hesaplayınız.

$$P_2 = \frac{M_2 \times n_2}{9550}$$

5. Redüktör ile makina arasında kullanılan bağlantı elemanına göre radyal yükü hesaplayınız. (Sayfa 20). Yukarıdaki verilere uygun olarak çıkış devri, değerlerine uyan servis faktörü ve radyal yükü bulduğunuzdan daha yüksek veya eşit olan redüktörü, güç-devir seçim tablolarından seçiniz. Helisel tip redüktörlerde verim yüksek olduğundan çıkış gücü verilmemiştir. Hesapladığınız güç değerini giriş gücü olarak kabul edip seçiminizi yapınız. Tablolarda verilen  $M_2$  çıkış momentinin hesapladığınız  $M_2$  den büyük olmasına dikkat ediniz. Eğer seçilen redüktörünki daha ufak ise bir üst motor gücüne geçiniz.

#### Örnek

##### 1. Makina Cinsi:

Lastik bantlı konveyör , dökme yük taşıyor.

##### 2. Makina için gerekli moment:

Makina için hesaplanan moment  $M_2 = 470 \text{ Nm}$ .

##### 3. Makina gerekli çıkış devri:

$n_2 = 50 \text{ dev/dak}$ .

##### 4. Günlük çalışma süresi:

16 saat.

##### 5. Saatte start sayısı:

Saatte 1 start

##### 6. Makina ile bağlantı şekli:

Zincir dişli ( çap -130 mm )

- Yük sınıflandırma tablosundan yük sınıfı M olarak seçilir (sayfa 17-18)

- Günlük çalışma süresi 16 saat Saatte start sayısı 1 ve yük sınıfı M'ye tekabül eden servis faktörü tablosundan, servis faktörü için  $fs = 1.3$  değeri bulunur.(sayfa 16)

- Makinanızın güç ihtiyacı (Redüktör Çıkış Gücü) :

$$P_2 = \frac{M_2 \times n_2}{9550} = \frac{470 \times 50}{9550} = 2,46 \text{ kW}$$

#### Gearbox Selection

For the correct selection of the appropriate gear units follow this steps.

1.Determine service factor (fs) on the basis of running conditions (Page 16).

2. Determine the required Torque  $M_2$  (required output torque of gearbox) for the driven machine.

3. Determine required speed (output speed of gearbox) for the driven machine.

4. Calculate the required power for your machine(Calculate power " $P_2$ " required at output side of gear reducer using the formula);

$$P_2 = \frac{M_2 \times n_2}{9550}$$

5. Calculate overhung load required at output shaft according to type of connection between gear unit and machine (Refer to directions and values given on page 20). After determining the above mentioned values, the gear reducer which corresponds to our requirements can be selected from the performance tables (the service factor and the permissible overhung load should be less than or equal to our requirement). For Helical gears the output power is not given on the performance tables because they have high efficiency and the output power can be taken as input power. The output torque should be checked if it meets to our requirements. If the output torque is low, search for a higher input power gearbox.

#### Example:

##### 1. Machine Type:

Belt Conveyor (Bulk Load)

##### 2. Required Torque:

Required Torque calculated for the driven machine is  $M_2=470 \text{ Nm}$ .

##### 3. Required speed:

$n_2 = 50 \text{ rpm}$

##### 4. Running time:

16 hours per day

##### 5. Frequency of starting:

1 start per hour

##### 6. Connection type between gear reducer

Chain drive (output dimension-130 mm)

- From the load classification table (on page 17-18), the load class M can be selected for the known application.

- The service factor can be selected as  $fs = 1,3$  from the service factor table (page 16) by taking into consideration 16 hours running time, one start per hour, and load class M.

-Required power for your machine(Power at output side of gear reducer) :

$$P_2 = \frac{M_2 \times n_2}{9550} = \frac{470 \times 50}{9550} = 2,46 \text{ kW}$$

#### Getriebeauswahl

Für die korrekte Auswahl des Antriebes;

1. Den Betriebsfaktor(fs) in Abhängigkeit von den Betriebsbedingungen bestimmen.(Bezug auf Seite 16).

2. Die erforderte Drehmoment  $M_2$  für die angetriebene Maschine (Abtriebsdrehmoment für die Getriebe) bestimmen.

3. Erforderte Drehzahl bestimmen (Abtriebsdrehzahl für die Getriebe).

4. Berechnen der erforderte Leistung der angetriebene Maschine (Die an der Abtriebswelle erforderte Leistung " $P_2$ " mit der unten angegebenen Formel.

$$P_2 = \frac{M_2 \times n_2}{9550}$$

5. Die an der Getriebeabtriebswelle erforderte Querkraft in Abhängigkeit von Antriebsselement bestimmen (Bezug auf Seite 20). Nach Bestimmen der oben angegebenen Werte, die passende Getriebe kann von den angegebenen Leistungstabellen entnommen werden. Dabei soll darauf geachtet werden, dass der Betriebsfaktor und Querkraft stets unterhalb von angegebenen Werten liegt. Weil Stirnradgetrieben einen hohen Wirkungsgrad haben, sind die Abtriebsleistungen für Stirnradgetrieben nicht angegeben. Bei dieser Getrieben die erforderte Leistung kann als Antriebsleistung benutzt werden. Achten sie darauf, dass der Abtriebsmoment größer als die erforderte Drehmoment ist.

#### Beispiel:

##### 1. Maschinentyp:

Gurtbandförderer (Schüttgut)

##### 2. Erforderte Drehmoment:

Für die Maschine berechnete Drehmoment  $M_2 = 470 \text{ Nm}$ .

##### 3. Erforderte Drehzahl:

$n_2 = 50 \text{ upm}$

##### 4. Betriebsdauer:

16 stunden pro Tag

##### 5. Schalthäufigkeit:

1 Start pro Stunde

##### 6. Antriebsselement für verbindung

Getriebe-Maschine:Kettentrieb(Durchmesser-130 mm)

- Von den Belastungsart Tabellen(Seite 17-18) nimmt man Belastungsart M

- Für den Schaltungzahl 1 und die Laufzeit16 und für den passenden Belastungsart erhält man Betriebsfaktor  $fs = 1,3$  von Tabelle auf Seite 16.

- Erforderte Leistung der angetriebe Maschine (Die an der Getriebeabtriebswelle erforderte Leistung)

$$P_2 = \frac{M_2 \times n_2}{9550} = \frac{470 \times 50}{9550} = 2,46 \text{ kW}$$

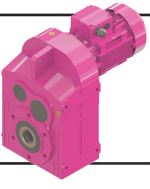

## Genel Bilgiler General Information Einführung



- Zincir dişli uygulaması için (Sayfa 21) Fq değeri;

$$F_q = \frac{2100 \times M_2}{D} = \frac{2100 \times 470}{130} = 7592 \text{ N}$$

- Ortaya çıkan redüktör ihtiyacı

$$\begin{aligned} P_2 &\geq 2,46 \text{ kW} \\ M_2 &\geq 470 \text{ Nm} \\ fs &\geq 1,3 \\ n_2 &\geq 50 \text{ d/dak} \\ F_q &\geq 7592 \text{ N} \end{aligned}$$

Güç ve devir sayılarından,

**DR373-3E100L/4D** seçilir (Sayfa 73).

$$\begin{aligned} P_2 &= 3 \text{ kW} > 2,46 \text{ kW} \\ M_2 &= 517 \text{ Nm} > 470 \text{ Nm} \\ fs &= 1,3 \\ n_2 &= 53 \text{ d/dak} \end{aligned}$$

$$F_{qam} = 16884 \text{ Nm} > 7592 \text{ Nm}$$

$$i = 27,53$$

- For chain drive application the requested overhang load can be calculated from (page 21).;

$$F_q = \frac{2100 \times M_2}{D} = \frac{2100 \times 470}{130} = 7592 \text{ N}$$

- The required gearbox is as follows:

$$\begin{aligned} P_2 &\geq 2,46 \text{ kW} \\ M_2 &\geq 470 \text{ Nm} \\ fs &\geq 1,3 \\ n_2 &\geq 50 \text{ rpm} \\ F_q &\geq 7592 \text{ N} \end{aligned}$$

From the performance table,

**DR373-3E100L/4D** selected (Page 73).

$$\begin{aligned} P_2 &= 3 \text{ kW} > 2,46 \text{ kW} \\ M_2 &= 517 \text{ Nm} > 470 \text{ Nm} \\ fs &= 1,3 \\ n_2 &= 53 \text{ rpm} \end{aligned}$$

$$F_{qam} = 16884 \text{ Nm} > 7592 \text{ Nm}$$

$$i = 27,53$$

- Für Kettentrieb die erforderte Querkraft (seite 21);

$$F_q = \frac{2100 \times M_2}{D} = \frac{2100 \times 470}{130} = 7592 \text{ N}$$

- Von den oben angegebenen Berechnungen die erforderte Getriebe ist wie folgt;

$$\begin{aligned} P_2 &\geq 2,46 \text{ kW} \\ M_2 &\geq 470 \text{ Nm} \\ fs &\geq 1,3 \\ n_2 &\geq 50 \text{ U/min} \\ F_q &\geq 7592 \text{ N} \end{aligned}$$

Von der Leistung- DrehzahlTabelle ,

wurde **DR373-3E100L/4D** gewählt (Seite 73).

$$\begin{aligned} P_2 &= 3 \text{ kW} > 2,46 \text{ kW} \\ M_2 &= 517 \text{ Nm} > 470 \text{ Nm} \\ fs &= 1,3 \\ n_2 &= 53 \text{ U/min} \end{aligned}$$

$$F_{qam} = 16884 \text{ Nm} > 7592 \text{ Nm}$$

$$i = 27,53$$

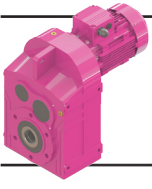

# Genel Bilgiler

## General Information

### Einführung



### Redüktör Seçim Formu

Kullanıldığı Sektör.....  
Kullanıldığı Yer.....  
Gerekli Ortalama Devir.....d/dak

#### Makina ihtiyaç gücü:

-Normal..... kW  
-En çok..... kW  
-En az..... kW

#### Tahrik Şekli:

AC Motor [ ]  
AC Motor + Invertör [ ]  
DC Motor [ ]  
Hidromotor [ ]  
1-3 silindirli içten yanmalı [ ]  
2-4 silindirli içten yanmalı [ ]

#### Motor Bağlantı Şekli (Elektrik Motorları):

IEC B5 Flanşlı [ ]  
NEMA Flanşlı [ ]  
B3 Ayaklı [ ]

IEC veya NEMA flanş kodu. ....

#### Motor Gücü:

-Nominal..... kW

#### Motor Devri:

-Normal..... d/dak  
-En çok..... d/dak  
-En az..... d/dak

#### Motor Torku:

-Normal..... Nm  
-En çok..... Nm  
-En az..... Nm

#### Dönüş şekli:

saat yönü [ ] saat yönüne ters [ ] değişken [ ]

#### Günlük çalışma süresi:

<4 [ ] 4-8 [ ] 8-16 [ ] >16 [ ]

#### Saatteki start sayısı:

0-50 [ ] 50-100 [ ] 100-200 [ ]  
200-300 [ ] 300-500 [ ] 500-700 [ ]  
700-1000 [ ] >1000 [ ]

Motor Redüktör Arası Tahvil Oranı.....

Kalkış için gerekli moment.....Nm

#### Saatteki pik moment adedi:

1-5 [ ] 6-30 [ ] 31-100 [ ] >100 [ ]

#### Bir çevrimde aktif çalışma oranı (ED):

%100 [ ] %80 [ ] %60 [ ] 40% [ ] %20 [ ]

#### Deniz seviyesinden yükseklik:

<1000 [ ] <2000 [ ] <3000 [ ]  
<4000 [ ] <5000 [ ]

#### Montaj yeri:

Küçük kapalı oda (w<1m/sn) [ ]  
Kapalı oda (w<3m/sn) [ ]  
Büyük oda ve holler (w>=3m/sn) [ ]  
Tamamen açık ortam [ ]

#### Çevre Şartları:

Normal [ ] Tozlu [ ] Nemli [ ]  
Korozif [ ] Kuru [ ]

#### Çevre Sıcaklığı:

Ortalama..... °C  
En Yüksek..... °C  
En Düşük..... °C

#### Kilit İhtiyacı:

Var [ ] Yok [ ]

#### Redüktör Giriş Opsiyonu:

R.. [ ] V.. [ ] N.. [ ] T.. [ ]

#### Redüktör Çıkış Opsiyonu:

00 [ ] 01 [ ] 02 [ ] 03 [ ] 0S [ ]

#### Montaj Pozisyonu:

M1 [ ] M2 [ ] M3 [ ] M4 [ ] M5 [ ] M6 [ ]

#### Giriş mili bağlantı şekli:

Elastik kaplin [ ]  
Fıçı tipi kaplin [ ]  
Rijit kaplin [ ]  
Hidrolik Kaplin [ ]  
Kayış kasnak [ ]  
Zincir dişli [ ]  
Pinyon dişli [ ]  
Bağlantı elemanı çapı.....mm  
Radyal yük.....N  
Radyal yük "u" mesafesi.....mm  
Aksiyal yük (mile doğru +).....N

#### Çıkış mili bağlantı şekli:

Elastik kaplin [ ]  
Fıçı tipi kaplin [ ]  
Rijit kaplin [ ]  
Kayış kasnak [ ]  
Zincir dişli [ ]  
Pinyon dişli [ ]  
Delik milli tork kolu [ ]  
Sıkma bilezikli tork kolu [ ]  
Bağlantı elemanı çapı.....mm  
Radyal yük.....N  
Radyal yük "u" mesafesi.....mm  
Aksiyal yük (mile doğru +).....N

#### Redüktör bağlantı yeri:

Gövde [ ] Flanş [ ] Tork kolu [ ]

#### Çıkış Mili Özelliği:

Dolu Mil Kamalı [ ]  
Dolu Mil Kamasız [ ]  
Delik Milli Sıkma Bilezikli [ ]  
Delik Milli [ ]  
Özel Mil [ ]

#### Giriş Mili Özelliği:

Kamalı [ ]  
Kamasız düz mil [ ]  
Özel Mil [ ]

**Tork kolu** [ ] Var [ ] Yok

#### Elektrik Gerilimi:

AC-Monofaze [ ] AC-Trifaze [ ] DC [ ]  
Voltaj.....Volt  
Frekans.....Hz

#### Koruma Sınıfı:

IP55 [ ] IP65 [ ] Exproof [ ]  
Diğer IP.....

#### Ekler:

Yük diyagramı [ ]  
Proje [ ]  
İstenen ana boyutlar [ ]  
Teknik veriler [ ]

#### Diğer Notlar:

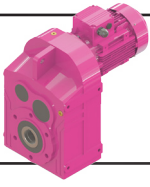

# Genel Bilgiler

## General Information

### Einführung



#### Gearbox Selection Form

Field of Industry.....  
 Application.....  
 Required Average Speed..... rpm

#### Required Power on Driven Machine:

-Normal..... kW  
 -Maximum..... kW  
 -Minimum..... kW

#### Driving Machine:

AC Motor [ ]  
 AC Motor + Inverter [ ]  
 DC Motor [ ]  
 Hydraulic Motor [ ]  
 Piston Engine with 1-3 cylinder [ ]  
 Piston Engine with 4-24 cylinder [ ]

#### Motor Connection Type (Electric Motors):

IEC B5 Flange [ ]  
 NEMA Flange [ ]  
 B3 Foot Mounted [ ]

IEC or NEMA Flange Code.....

#### Motor Power:

-Nominal.....kW

#### Motor Speed:

-Normal.....rpm  
 -Maximum.....rpm  
 -Minimum.....rpm

#### Motor Torque:

-Normal.....Nm  
 -Maximum.....Nm  
 -Minimum.....Nm

#### Direction of Rotation:

cw [ ] ccw [ ] variable [ ]

#### Working hours per day:

<4 [ ] 4-8 [ ] 8-16 [ ] >16 [ ]

#### Startings per cycle:

0-50 [ ] 50-100 [ ] 100-200 [ ]  
 200-300 [ ] 300-500 [ ] 500-700 [ ]  
 700-1000 [ ] >1000 [ ]

Transmission ratio between motor and gear unit.....

Required Starting Torque.....Nm

#### Peak torques per hour:

1-5 [ ] 6-30 [ ] 31-100 [ ] >100 [ ]

#### Effective working time in a cycle (ED):

%100 [ ] %80 [ ] %60 [ ] 40% [ ]  
 20% [ ]

#### Altitude:

<1000 [ ] <2000 [ ] <3000 [ ]  
 <4000 [ ] <5000 [ ]

#### Mounting Place:

Small closed room (w<1m/sn) [ ]  
 Closed room (w<3m/sn) [ ]  
 Big rooms and halls (w>=3m/sn) [ ]  
 Outdoor [ ]

#### Ambient Conditions:

Normal [ ] Dusty [ ] Humid [ ]  
 Corrosive [ ] Dry [ ]

#### Ambient Temperature:

Average.....°C  
 Maximum.....°C  
 Minimum.....°C

#### Backstop Required:

Yes [ ] No [ ]

#### Gearbox input options:

R.. [ ] V.. [ ] N.. [ ] T.. [ ]

#### Gearbox output options:

00 [ ] 01 [ ] 02 [ ] 03 [ ] 0S [ ]

#### Mounting Position:

M1 [ ] M2 [ ] M3 [ ] M4 [ ] M5 [ ] M6 [ ]

#### Input Shaft Connection Type:

Elastic Coupling [ ]  
 Barrel Type Coupling [ ]  
 Hydraulic Coupling [ ]  
 Rigid Flange Coupling [ ]  
 Pulley [ ]  
 Chain Sprocket [ ]  
 Pinion [ ]  
 Diameter of Connection element.....mm  
 Radial Load.....N  
 "u" Distance of Radial Load.....mm  
 Axial Load (Towards Shaft +) .....N

#### Output Shaft Connection Type:

Elastic Coupling [ ]  
 Barrel Type Coupling [ ]  
 Rigid Flange Coupling [ ]  
 Pulley [ ]  
 Chain Sprocket [ ]  
 Pinion [ ]  
 Hollow Shaft with Torque Arm [ ]  
 Shrinck disc with Torque Arm [ ]  
 Diameter of Connection Element.....mm  
 Radial Load.....N  
 "u" Distance of Radial Load.....mm  
 Axial Load (Towards Shaft) .....N

#### Gearbox assembled by:

Housing [ ] Flange [ ] Torque Arm [ ]

#### Output Shaft Specification:

Solid Shaft with Keyway [ ]  
 Solid Shaft without Keyway [ ]  
 Hollow Shaft with Shrinck Disc [ ]  
 Hollow Shaft [ ]  
 Special Shaft [ ]

#### Input Shaft Specification:

Solid Shaft with Keyway [ ]  
 Solid Shaft without Keyway [ ]  
 Special Shaft [ ]

**Torque arm** required Yes [ ] No [ ]

#### Electrical Supply:

AC-1 Phase [ ] AC-3 Phase [ ] DC [ ]  
 Voltage.....Volt  
 Frequency..... Hz

#### Protection Class:

IP55 [ ] IP65 [ ] Exproof [ ]  
 Other IP.....

#### Attachments:

Load Diagram [ ]  
 Project [ ]  
 Required Dimensions [ ]  
 Technical Specifications [ ]

#### Notes:



# Genel Bilgiler

## General Information

### Einführung



#### Formular für Getriebeauswahl

Industriebereich.....  
 Anwendung.....  
 Erforderliche Drehzahl.....U/min

#### Erforderliche Leistung für die Maschine:

-Normal.....kW  
 -Minimal.....kW  
 -Maximal.....kW

#### Antriebsmaschine:

AC Motor [ ]  
 AC Motor mit Frequenzumrichter [ ]  
 DC Motor [ ]  
 Hydromotor [ ]  
 Kolbenmaschinen mit 1-3 Zylinder [ ]  
 Kolbenmaschinen mit 2-4 Zylinder [ ]

#### Motorverbindungsart (Elektromotoren):

IEC B5 Flansch [ ]  
 NEMA Flansch [ ]  
 B3 Fussausführung [ ]

IEC oder NEMA Flanschcode.....

#### Motorleistung:

-Nominal.....kW

#### Motordrehzahl:

-Normal.....U/min  
 -Maximal .....U/min  
 -Minimal.....U/min

#### Motordrehmoment:

-Normal.....Nm  
 -Maximal.....Nm  
 -Minimal.....Nm

#### Drehrichtung:

in Uhrzeigersinn [ ] gegen Uhrzeigersinn [ ]  
 veränderlich [ ]

#### Betriebsdauer in Stunden pro Tag:

<4 [ ] 4-8 [ ] 8-16 [ ] >16 [ ]

#### Anzahl der Anläufe pro Stunde:

0-50 [ ] 50-100 [ ] 100-200 [ ]  
 200-300 [ ] 300-500 [ ] 500-700 [ ]  
 700-1000 [ ] >1000 [ ]

Übersetzung zwischen Motor und Antriebswelle.....

Erforderliches Anlaufmoment.....Nm

#### Häufigkeit von Lastspitzen pro Stunde:

1-5 [ ] 6-30 [ ] 31-100 [ ] >100 [ ]

#### Einschaltdauer je Stunde (ED):

%100 [ ] %80 [ ] %60 [ ] 40% [ ] %20 [ ]

#### Höhenlage über Meeresspiegel (m):

<1000 [ ] <2000 [ ] <3000 [ ]  
 <4000 [ ] <5000 [ ]

#### Betriebsort:

Kleine geschlossene Räume (w<1m/sn) [ ]  
 Geschlossene Räume (w<3m/sn) [ ]  
 Große Räume und Hallen (w>=3m/sn) [ ]  
 im Freien [ ]

#### Umgebungsbedingungen:

Normal [ ] Staubig [ ] Feucht [ ]  
 Korrodierend [ ] Trocken [ ] Verklebend [ ]

#### Umgebungstemperatur:

Mittelwert .....°C  
 Maximal.....°C  
 Minimal.....°C

#### Rücklauf Sperre erforderlich:

Ja [ ] Nein [ ]

#### Getriebeeingangsvarianten:

R..[ ] V..[ ] N..[ ] T..[ ]

#### Getriebeausgangsvarianten:

00 [ ] 01 [ ] 02 [ ] 03 [ ] 0S [ ]

#### Montageposition:

M1 [ ] M2 [ ] M3 [ ] M4 [ ] M5 [ ] M6 [ ]

#### Antriebswellenanschluss:

Elastische Kupplung [ ]  
 Trommelkupplung [ ]  
 Hydrokupplung [ ]  
 Starre Flanschkupplung [ ]  
 Keilriementrieb [ ]  
 Kettenrad [ ]  
 Ritzel [ ]  
 Durchmesser von Anschlusselement.....mm  
 Querkraft.....N  
 "u" Abstand von der Wellenschulter.....mm  
 Axialkraft (in Richtung der Welle +) .....N

#### Abtriebswellenanschluss:

Elastische Kupplung [ ]  
 Trommelkupplung [ ]  
 Starre Flanschkupplung [ ]  
 Keilriementrieb [ ]  
 Kettenrad [ ]  
 Ritzel [ ]  
 Hohlwelle mit Drehmomentstütze [ ]  
 Schrumpfscheibe mit Drehmomentstütze [ ]  
 Durchmesser von Anschlusselement.....mm  
 Querkraft.....N  
 "u" Abstand von der Wellenschulter.....mm  
 Axialkraft (in Richtung der Welle +) .....N

#### Montage zur Getriebegehäuse mit:

Gehäuse [ ] Flansch [ ] Drehmomentstütze [ ]

#### Eigenschaften der Abtriebswelle:

Vollwelle mit Passfeder [ ]  
 Vollwelle ohne Passfeder [ ]  
 Sonderwelle [ ]  
 Hohlwelle mit Schrumpfscheibe [ ]  
 Hohlwelle [ ]

#### Eigenschaften der Antriebswelle:

Vollwelle mit Paßfeder [ ]  
 Vollwelle ohne Paßfeder [ ]  
 Sonderwelle [ ]

#### Drehmomentstütze erforderlich Ja [ ] Nein [ ]

#### Spannungsversorgung:

AC-1 phasig [ ] AC-3 phasig [ ] DC [ ]  
 Spannung.....Volt  
 Frequenz.....Hz

#### Schutzart:

IP55 [ ] IP65 [ ] Exproof [ ]  
 Andere IP.....

#### Anhang:

Lastdiagramm [ ]  
 Projekt [ ]  
 Erforderliche Abmessungen [ ]  
 Technische Spezifikationen [ ]

#### Andere Merkmale:

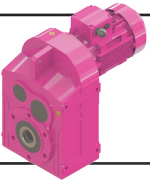

# Genel Bilgiler

## General Information

### Einführung



#### Yağlama

Redüktörlerin uzun ömürlü olması ve iyi performansla çalışabilmesi için, kullanılan yağın seçimi doğru olmalı ve belirtilen zamanlarda değişimleri yapılmalıdır.

Yağın seçiminde devir, çevre sıcaklığı, redüktör yağ sıcaklığı, çalışma koşulları ve yağ ömrü önem taşımaktadır. Redüktörler yağı doldurulmuş olarak sevkedilmektedir. Redüktörler uzun süre depolanacakları zaman veya çalışmaya başlanacağı zaman çalışma konumuna göre üstte kalan tapa sökülmesi ve redüktörün beraberinde verilen havalandırma tapası kullanılmalıdır. Bu redüktörün iç basıncından dolayı oluşacak yağ sızmalarını önleyecektir.

Redüktörlerde standart olarak kullanılan yağlar 33. sayfadaki tabloda verilmiştir. Miktarlar ve yağ tipi burada verilen değerlerden farklılık gösterilebilir. Redüktörünüzde kullanılan yağın tipi ve miktarı için lütfen etiketine bakınız. Eğer Siparişte belirtilmezse D Serisi Redüktörler M1 montaj pozisyonuna göre yağ ile doldurulur. Bu pozisyonlar dışındaki çalışma durumlarında tablolarda verilen yağ miktarlarına göre ilave veya eksiltme yapılmalıdır. Özel çalışma koşullarında firmamıza danışmanız tavsiye edilir.

Mineral yağlar her 10.000 çalışma saatinde, sentetik yağlar ise her 20.000 çalışma saatinde değiştirilmelidir. Ağır çevre koşullarında (ani ısı değişiklikleri, yüksek nemlilik v.b) yağ değiştirme periyotlarının kısaltılması tavsiye edilir. Mineral yağlar ile sentetik yağlar birbirine kesinlikle karıştırılmamalıdır. Değiştirme işlemi bir çalışma periyodunun hemen peşinden ve yağ sıcakken yapılmalıdır. Bu şekilde bir değiştirme, redüktör içindeki partiküllerin yağa karışmış olarak bulunmasından dolayı iyi bir temizleme ve yağın rahat boşalması neticesini verecektir.

#### Lubrication

*To work in perfect condition and to have long life for the gearbox the lubricant must be chosen correctly and changed in time.*

*In selection of oil it is important to consider speed, ambient temperature, gear box oil temperature, working conditions and the life required from the lubricant. All units are filled with lubricant before shipping. Before the gearbox is stored for a long time or before starting up, the top plug (according to the working position) must be removed and the extra given vent plug must be replaced. This prevents excessive pressure which causes oil leakages.*

*The lubricant in the standard line is given for standard fillings on the table page 33. Please look at your gear units label for filled oil type and quantity. If the mounting position not indicated on order, D Series gearboxes are filled with mounting position of M1. For other mounting positions please filling oil or draining oil refer to the table given on the next pages. For special working conditions please contact us.*

*The mineral lubricant should be changed after every 10.000 service hours and the synthetic lubricant should be changed after every 20.000 working hours. If the operation conditions are very heavy (e.g. high temperature differences, high humidity) shorter intervals between changes are recommended. Mineral and synthetic oils must not be mixed up. By changing the lubricant complete cleaning is advised. The oil change should be done after a working period. Because oil is hot in this condition and impurities are mixed with it the changing of oil will be done in best result and the oil will drain easily.*

#### Schmierung

Um eine lange Lebensdauer zu gewährleisten muss der Schmierstoff richtig ausgewählt werden.

Für die richtige Ölauswahl müssen Drehzahl, Umgebungstemperatur, Belastungsart und Lebensdauer des Öls berücksichtigt werden. Die mitgelieferte Entlüftungsschraube ist vor Inbetriebnahme oder längeren Lagern gegen die Einfüllschraube auszutauschen, um einen Überdruck im Getriebe und damit eine Undichtigkeit des Getriebes zu vermeiden. Getriebe und Getriebemotoren sind bei Auslieferung betriebsfertig gefüllt.

Ohne besondere Bestellangaben werden die Getriebe grundsätzlich mit den auf der Seite 33 in der grau unterlegten Spalte angegebenen Schmierstoffen gefüllt. Bitte im Getriebe verwendetes Öl und menge von dem Namenschild ablesen. Die fußbefestigten Getriebe sind befüllt für Bauform und die flanschbefestigten Getriebe für Bauform M1. Für andere Bauformen sind die auf der nächsten Seite angegebenen Füllmengen zu beachten.

Ein Schmierstoffwechsel sollte alle 10.000 Betriebsstunden durchgeführt werden. Für synthetische Produkte verdoppeln sich diese Fristen. Bei extremen Betriebsbedingungen, z.B. hohe Luftfeuchtigkeit, aggressiver Umgebung und hohen Temperaturschwankungen sind kürzere Schmierstoffintervalle vorteilhaft. Es ist empfehlenswert, dem Schmierstoffwechsel mit einer gründlichen Reinigung des Getriebes zu verbinden. Synthetische und mineralische Schmierstoffe dürfen nicht miteinander vermischt werden. Das Ablassen des Öls soll unmittelbar nach dem Stillsetzen erfolgen, solange das Öl noch warm ist. In dieser Zustand ist das Öl mit den Schmutzpartikeln vermischt, so dass eine Entfernung des Altöls eine gute Reinigung garantiert.

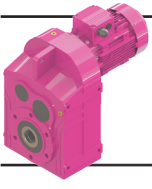

## Genel Bilgiler General Information Einführung



### M4 Montaj Pozisyonu için Genleşme Tankı / Expansion Tank for M4 Mounting Position / Ölausgleichsbehälter für M4 Bauform

Aşağıdaki teknik resimde gösterildiği gibi montaj pozisyonları **M4** (montaj pozisyonları syf.34) olan redüktörlerde düzgün bir yağlama sağlanabilmesi için yağ seviyesinin redüktörün üst dişlilerinin yağlanabileceği seviyede olması gerekmektedir. Buda düşük çevrim oranlı redüktörlerde köpürme ve genleşme nedeniyle havalandırma tapasından yağ atılmasına neden olabilmektedir.

Yılmaz redüktör ; bunun önlenmesi için çevrim oranı (i) < 20 ve D47'den daha büyük olan bütün gövdelerde **M4** montaj pozisyonunda genleşme tankı kullanılmasını kesinlikle önermektedir. Önerilen genleşme tankı ölçüleri aşağıdaki tabloda gösterilmiştir.

Çevrim oranı (i) < 20 olup giriş motor devri 1800 d/d dan büyük olan bütün redüktörlerde **M4** montaj pozisyonunda genleşme tankı kullanılması redüktör büyüklüğüne bakılmaksızın önerilmektedir.

*As you can see at the technical drawing below, for gear units with **M4** (mounting positions p. 34) mounting position, oil level is very high for proper lubrication of upper pinion gear and this leads to oil leakage from venting plug, because of foaming and expansion of oil at geared motors with ratios below 20.*

*We ; Yılmaz Redüktör, strongly recommend using expansion tank for **M4** mounting position for gear units D57, D67, D77, D87 and D97 with total ratios (i) below 20, to prevent this. You can find the recommended dimensions of expansion tanks below.*

*If your gear units total ratio (i) is below 20 and input speed is higher than 1800 rpm we recommend using of expansion tank for all gear unit sizes for **M4** mounting position.*

Wie in der folgenden technischen Zeichnung dargestellt ist, sollte der Ölstand auf der gleichen Höhe der ersten Getriebestufe sein, um eine ausreichende Schmierung des oberen Zahnrads bei der **M4** Bauform (s. Seite 34) sicher zu stellen. Aufgrund dieses hohen Ölstands bildet sich Ölschaum aus, welcher aus der Entlüftungsschraube austritt.

Um das verhindern zu müssen, empfiehlt Yılmaz Redüktör bei allen D-Serie Getrieben ab Getriebebaugröße D57 mit niedrigen Übersetzungen (i<20) einen Ölausgleichsbehälter bei der **M4** Bauform einzusetzen. Die empfohlenen Dimensionen des Ölausgleichsbehälters sind in der unteren Tabelle angegeben.

Bei Getrieben mit Übersetzungen (i<20) und bei Motor-Eingangsdrehzahlen >1800 min<sup>-1</sup> empfiehlt Yılmaz Redüktör einen Ölausgleichsbehälter unabhängig von der Getriebebaugröße einzusetzen.

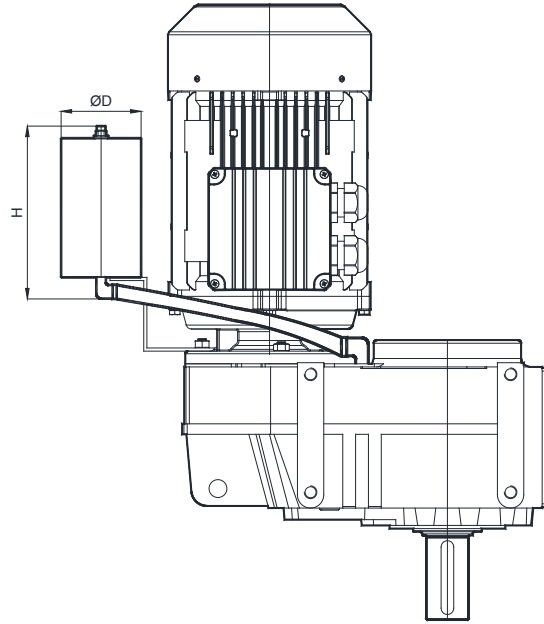

Gövde Büyüklüğü Housing Size Größe der Gehäuse	Genleşme Tankı Expansion Tank Ölausgleichsbehälter	D [mm]	H [mm]	Ağırlık [kg] Weight [kg] Gewicht [kg]
D57..	G1	100	150	4
D67.. , D77..	G2	150	250	5
D87.. , D97..	G3	180	400	9

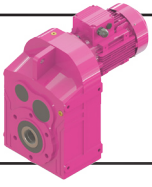

# Genel Bilgiler

## General Information

### Einführung



#### Yağ Tipleri / Oil Types / Schmierstoffe

Yağ Cinsi Lubricant Art des Schmierstoffes	DIN 51517-3	Çevre Sıcaklığı [°C] Ambient Temp. [°C] Umgebungstemp. [°C]	ISO VG	Aral	Beyond Petroleum	Castrol	Klüber Lubrication	Mobil	Shell	Total
		Daldırma Yağlama Dip Lubrication Tauchschmierung								
Mineral Yağlar Mineral Oil Mineralöl	CLP	0 ... +50	680	Degol BG 680	Energol GR-XP 680	Alpha SP 680	Klüberoil GEM 1-680 N	Mobilgear XMP 680	Omala S2 GX 680	Carter EP 680
		-5 ... +45	460	Degol BG 460	Energol GR-XP 460	Alpha SP 460	Klüberoil GEM 1-460 N	Mobilgear XMP 460	Omala S2 GX 460	Carter EP 460
		-10 ... +40	320	Degol BG 320	Energol GR-XP 320	Alpha SP 320	Klüberoil GEM 1-320 N	Mobilgear XMP 320	Omala S2 GX 320	Carter EP 320
		-15 ... +30	220	Degol BG 220	Energol GR-XP 220	Alpha SP 220	Klüberoil GEM 1-220 N	Mobilgear XMP 220	Omala S2 GX 220	Carter EP 220
		-20 ... +20	150	Degol BG 150	Energol GR-XP 150	Alpha SP 150	Klüberoil GEM 1-150 N	Mobilgear XMP 150	Omala S2 GX 150	Carter EP 150
		-25 ... +10	100	Degol BG 100	Energol GR-XP 100	Alpha SP 100	Klüberoil GEM 1-100 N	Mobilgear XMP 100	Omala S2 GX 100	Carter EP 100
Sentetik Yağlar Synthetic Oil Synthetisches Öl	CLP PG	-10 ... +60	680	Degol GS 680	Energol SG-XP 680	-	Klübersynth GH 6 -680	Mobil Glygoyle 680	Omala S4 WE 680	Carter SY 680
		-20 ... +50	460	Degol GS 460	Energol SG-XP 460	Alphasyn PG 460	Klübersynth GH 6 -460	Mobil Glygoyle 460	Omala S4 WE 460	Carter SY 460
		-25 ... +40	320	Degol GS 320	Energol SG-XP 320	Alphasyn PG 320	Klübersynth GH 6 -320	Mobil Glygoyle 320	Omala S4 WE 320	Carter SY 320
		-30 ... +30	220	Degol GS 220	Energol SG-XP 220	Alphasyn PG 220	Klübersynth GH 6 -220	Mobil Glygoyle 30	Omala S4 WE 220	Carter SY 220
		-35 ... +20	150	Degol GS 150	Energol SG-XP 150	Alphasyn PG 150	Klübersynth GH 6 -150	Mobil Glygoyle 22	Omala S4 WE 150	Carter SY 150
		-40 ... +10	100	-	-	-	Klübersynth GH 6 -100	Mobil Glygoyle 100	-	-
	CLP HC	-10 ... +60	680	-	-	-	Klübersynth GEM 4-680 N	Mobil SHC Gear 680	Omala S4 GXV 680	Carter SH 680
		-20 ... +50	460	Degol PAS 460	Energol EP-XF 460	Alphasyn T 460	Klübersynth GEM 4-460 N	Mobil SHC Gear 460	Omala S4 GXV 460	Carter SH 460
		-30 ... +40	320	Degol PAS 320	Energol EP-XF 320	Alphasyn T 320	Klübersynth GEM 4-320 N	Mobil SHC Gear 320	Omala S4 GXV 320	Carter SH 320
		-40 ... +40	220	Degol PAS 220	Energol EP-XF 220	Alphasyn T 220	Klübersynth GEM 4-220 N	Mobil SHC Gear 220	Omala S4 GXV 220	Carter SH 220
		-40 ... +40	150	Degol PAS 150	Energol EP-XF 150	Alphasyn T 150	Klübersynth GEM 4-150 N	-	Omala S4 GXV 150	Carter SH 150
		-40 ... +40	100	-	-	-	Klübersynth GEM 4-100 N	-	-	-
Gıda Uyumlu Yağ Food Grade Oil Lebensmittellöl	CLP NSF H1	-30 ... +25	220	-	-	Optileb GT 220	Klüberoil 4 UH1-220 N	Mobil SHC Cibus 220	-	Nevastane SL 220
Çevre Dostu Yağ Biodegradable Oil Biologisch abbaubares Öl	CLP E	-25 ... +40	320	-	-	Tribol BioTop 1418-320	Klübersynth GEM 2-320	-	-	Carter Bio 320

	Ürün Kodu Product Code Produktcode	Çalışma Sıcaklığı [°C] Working Temp. [°C] Betriebstemperatur [°C]	NLGI Sınıfı NLGI Grade NLGI-Klasse	Baz Yağı Base Oil Basis Öl	Renk Colour Farbe
Mineral Gresler Mineral Grease Mineral-Fett	Mobil XHP 223	-20 ... +140	NLGI 3	ISO VG220	Mavi Blue Blau
Sentetik Gresler Synthetic Grease Synthetisches Fett	Mobil SHC Grease 460 WT	-30 ... +150	NLGI 1.5	ISO VG460	Kırmızı Red Rot
	Mobilith SHC 100	-40 ... +150	NLGI 2	ISO VG100	
Gıda Uyumlu Gresler NSF H1 Food Grade Grease NSF H1 Lebensmittelfett NSF H1	Mobil SHC Polyrex 222	-30 ... +170	NLGI 2	ISO VG220	Beyaz White Weiß
	Castrol Optileb™ GR 823-2	-30 ... +120	NLGI 2	ISO VG192	
Sıvı Gresler (Mineral) Liquid Grease (Mineral) Flüssiges Fett (Mineral)	Shell Gadus S2 V 220 00	-20 ... +100	NLGI 00	ISO VG220	Kahverengi Brown Braun

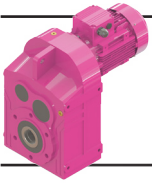

# Genel Bilgiler

## General Information

### Einführung



#### Montaj Pozisyonları / Mounting Positions / Bauformen

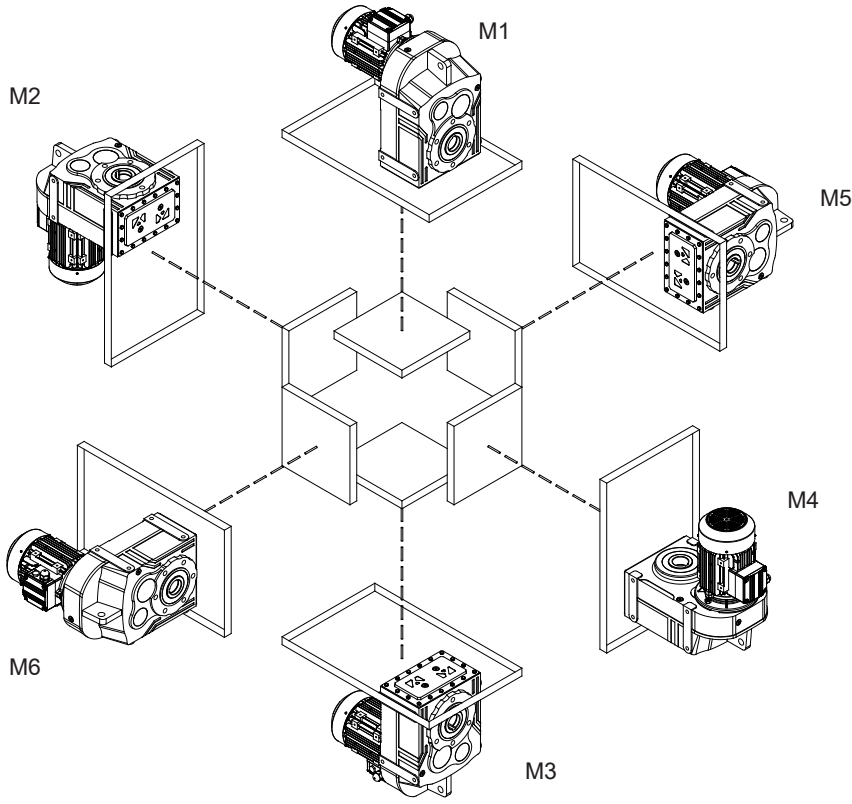

M1....M6 'ya kadar belirtilen montaj pozisyonları redüktörün duruş yönü referans alınarak belirlenmiştir. Montaj yüzeyleri bağlayıcı değildir.

Figured mounting positions of M1 to M6 are determined as reference of directional position of the gearbox. Mounting surfaces are not binding.

Dargestellte Montagepositionen M1 bis M6 wurden nach der Stehrichtung von Getriebe bestimmt. Montageoberflächen sind unverbindlich.

M1....M6 'ya kadar belirtilen montaj pozisyonları redüktörün duruş yönü referans alınarak belirlenmiştir. Montaj yüzeyleri bağlayıcı değildir.

Figured mounting positions of M1 to M6 are determined as reference of directional position of the gearbox. Mounting surfaces are not binding.

Dargestellte Montagepositionen M1 bis M6 wurden nach der Stehrichtung von Getriebe bestimmt. Montageoberflächen sind unverbindlich.

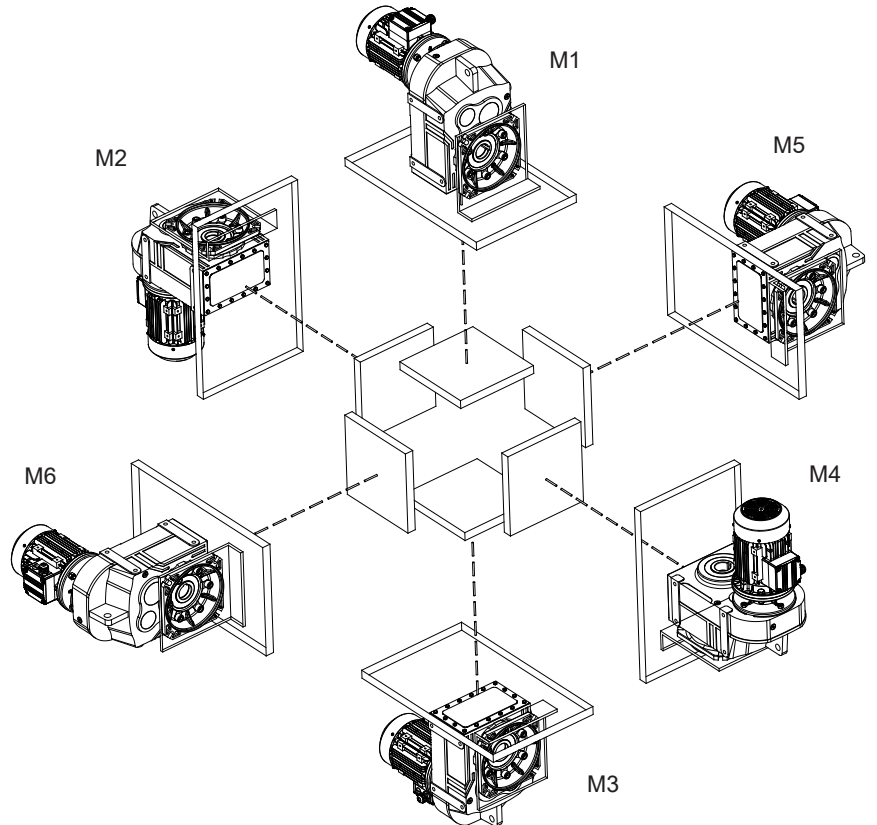

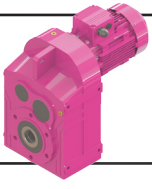

# Genel Bilgiler

## General Information

### Einführung



#### İki Üç Kademeli Helisel Dişli Delik Milli Redüktörler Yağ Seviye Tapaları

Two -Three Stage Helical Geared Hollow shaft Gearboxes Oil Level Plugs

Zwei-Dreistufig Stirnradgetriebe mit Hohlwelle Ölverschlußschrauben

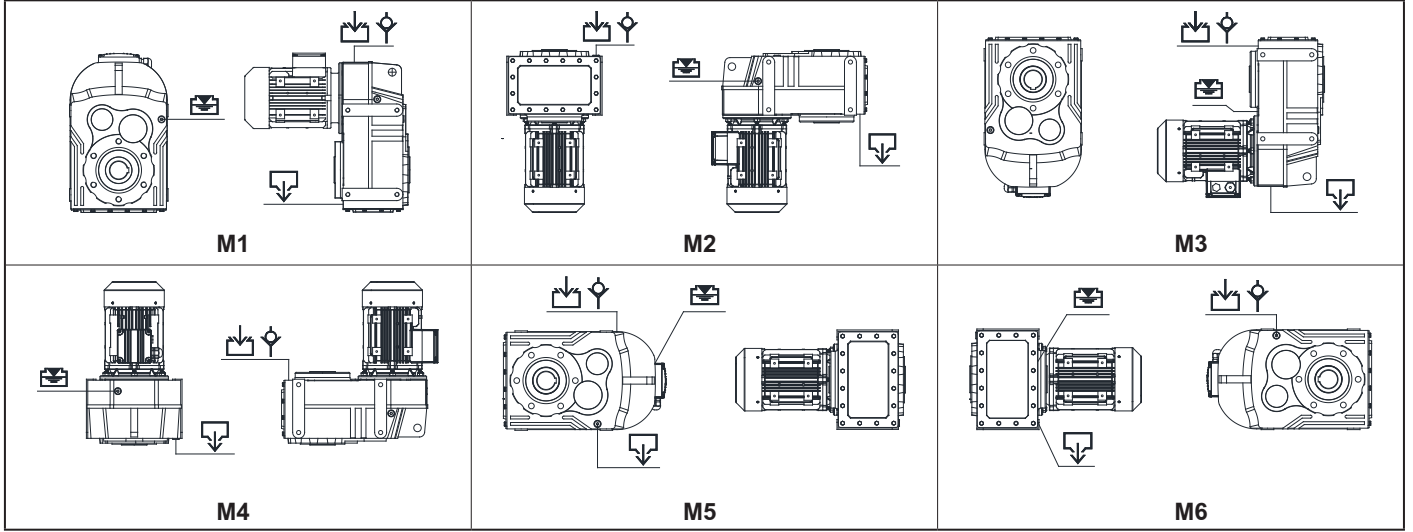

#### Yağ Miktarları (lt) / Oil Quantities (lt) / Ölmengen (lt)

Tip / Type / Typ	M1	M2	M3	M4	M5	M6
DR072	0.95	1.1	0.8	1.1	1.0	0.9
DR073	0.9	1.0	0.7	1.0	0.9	0.85
DR172	1.3	1.5	1.0	1.6	1.4	1.3
DR173	1.0	1.3	0.8	1.55	1.2	1.2
DR272	1.9	2.2	1.3	2.5	2.0	1.95
DR273	1.8	2.0	1.2	2.0	2.0	2.0
DR282	2.4	3.0	2.0	2.9	2.7	2.7
DR283	2.3	2.9	1.8	2.6	2.3	2.5
DR372	3.2	3.7	2.4	3.6	3.5	3.4
DR373	3.0	3.7	2.0	3.5	3.3	3.3
DR472	6.8	7.0	4.6	7.5	6.5	6.5
DR473	6.4	7.0	4.0	6.6	6.5	6.5
DR572	11.4	12.7	8.6	15.0	11.9	11.6
DR573	11.2	12.4	8.0	12.5	11.5	11.5
DR672	22.0	27.0	16.0	27.0	22.8	22.5
DR673	21.0	25.2	14.0	26.5	21.5	21.0
DR772	34.0	37.0	26.0	44.0	35.0	34.5
DR773	32.0	35.0	21.0	40.0	33.0	32.5
DR872	53.0	58.0	43.0	67.0	55.0	54.0
DR873	48.5	53.0	39.0	61.0	50.0	49.0
DR972	87.0	113.0	80.5	117.0	97.0	95.0
DR973	84.0	110.0	77.0	112.0	93.0	89.0

Semboller :

Symbols :

Symbole :



:Yağ doldurma

:Oil filling

:Öfüllung



:Yağ boşaltma

:Drain plug

:Ölauslass



:Yağ seviyesi

:Oil level

:Ölstand



:Havalandırma

:Vent Plug

:Entlüftungsschraube

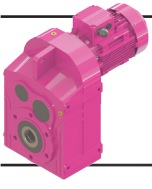

# Genel Bilgiler

## General Information

### Einführung



**Dört Kademeli Helisel Dişli Delik Milli Redüktörler Yağ Seviye Tapaları**  
*Four Stage Reduction Helical Hollow Shaft Gearboxes Oil Level Plugs*  
Vierstufig Stirnradgetriebe mit Hohlwelle Ölverschlußschrauben

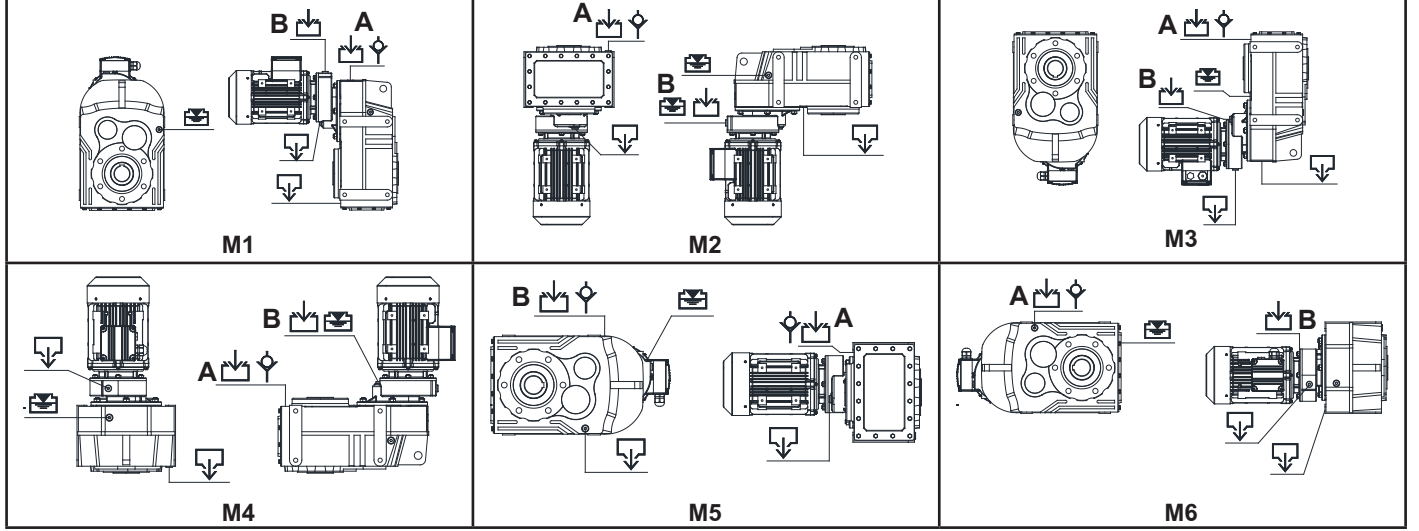

**Yağ Miktarları (lt) / Oil Quantities (lt) / Ölmengen (lt)**

Tip / Type / Typ	M1 A / B	M2 A / B	M3 A / B	M4 A / B	M5 A / B	M6 A / B
DR474	6.4 / 0.25	7.0 / 0.25	4.0 / 0.25	6.6 / 0.25	6.5 / 0.25	6.5 / 0.25
DR574	11.2 / 0.4	12.4 / 0.4	8.0 / 0.4	12.5 / 0.4	11.5 / 0.4	11.5 / 0.4
DR674	21.0 / 0.5	25.2 / 0.5	14.0 / 0.5	26.5 / 0.5	21.5 / 0.5	21.0 / 0.5
DR774	32.0 / 0.9	35.0 / 0.9	21.0 / 0.9	40.0 / 0.9	33.0 / 0.9	32.5 / 0.9
DR874	48.5 / 3.5	53.0 / 3.5	39.0 / 3.5	61.0 / 3.5	50.0 / 3.5	49.0 / 3.5
DR974	84.0 / 5.0	110.0 / 5.0	77.0 / 5.0	112.0 / 5.0	93.0 / 5.0	89.0 / 5.0

**Semboller :**  
Symbols :  
Symbole :

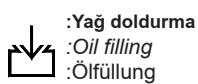

:Yağ doldurma  
:Oil filling  
:Ölfüllung

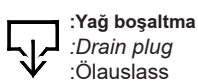

:Yağ boşaltma  
:Drain plug  
:Ölauslass

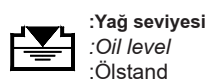

:Yağ seviyesi  
:Oil level  
:Ölstand



:Havalandırma  
:Vent Plug  
:Entlüftungsschraube

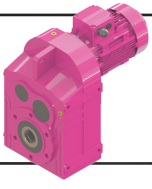

# Genel Bilgiler

## General Information

### Einführung



#### Beş-Altı Kademeli Helisel Dişli Delik Milli Redüktörler Yağ Seviye Tapaları

Five-Six Stage Helical Geared Hollow Shaft Gearboxes Oil Level Plugs

Fünf-Sechsstufig Stirnradgetriebe mit Hohlwelle Ölverschlußschrauben

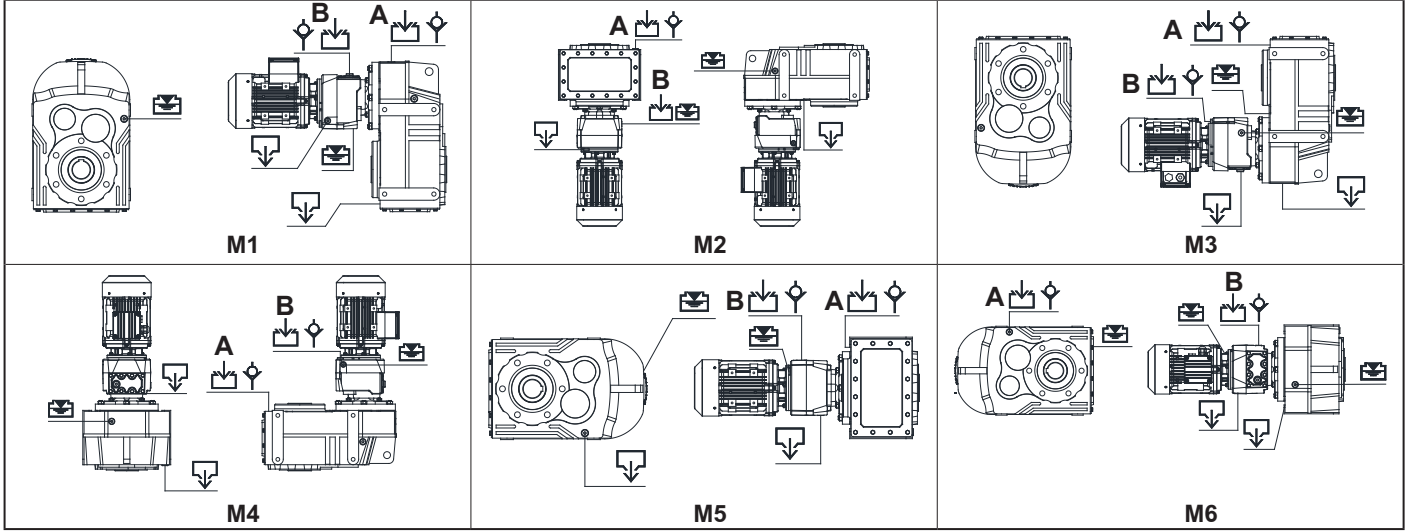

#### Yağ Miktarları (lt.) / Oil Quantities. (lt) / Ölmengen (lt.)

Tip / Type / Typ	M1 A / B	M2 A / B	M3 A / B	M4 A / B	M5 A / B	M6 A / B
DR275	1.8 / 0.4	2.0 / 0.6	1.2 / 0.5	2.0 / 0.6	2.0 / 0.5	2.0 / 0.5
DR276	1.8 / 0.35	2.0 / 0.5	1.2 / 0.5	2.0 / 0.55	2.0 / 0.4	2.0 / 0.4
DR285	2.3 / 0.4	2.9 / 0.6	1.8 / 0.5	2.6 / 0.6	2.3 / 0.5	2.5 / 0.5
DR286	2.3 / 0.35	2.9 / 0.55	1.8 / 0.5	2.6 / 0.55	2.3 / 0.4	2.5 / 0.4
DR375	3.0 / 0.4	3.7 / 0.6	2.0 / 0.5	3.5 / 0.6	3.3 / 0.5	3.3 / 0.5
DR376	3.0 / 0.35	3.7 / 0.55	2.0 / 0.5	3.5 / 0.55	3.3 / 0.4	3.3 / 0.4
DR475	6.4 / 0.65	7.0 / 0.95	4.0 / 0.7	6.6 / 0.95	6.5 / 0.7	6.5 / 0.7
DR476	6.4 / 0.6	7.0 / 0.8	4.0 / 0.7	6.6 / 0.8	6.5 / 0.65	6.5 / 0.65
DR575	11.2 / 1.2	12.4 / 2.1	8.0 / 2.0	12.5 / 2.1	11.5 / 1.4	11.5 / 1.4
DR576	11.2 / 1.1	12.4 / 2.0	8.0 / 1.9	12.5 / 2.0	11.5 / 1.3	11.5 / 1.3
DR675	21.0 / 1.2	25.2 / 2.1	14.0 / 2.0	26.5 / 2.1	21.5 / 1.4	21.0 / 1.4
DR676	21.0 / 1.1	25.2 / 2.0	14.0 / 1.9	26.5 / 2.0	21.5 / 1.3	21.0 / 1.3
DR775	32.0 / 2.0	35.0 / 3.4	21.0 / 3.1	40.0 / 3.4	33.0 / 2.8	32.5 / 2.8
DR776	32.0 / 1.9	35.0 / 3.3	21.0 / 3.0	40.0 / 3.3	33.0 / 2.6	32.5 / 2.6
DR875	48.5 / 2.0	53.0 / 3.4	39.0 / 3.1	61.0 / 3.4	50.0 / 2.8	49.0 / 2.8
DR876	48.5 / 1.9	53.0 / 3.3	39.0 / 3.0	61.0 / 3.3	50.0 / 2.6	49.0 / 2.6
DR975	84.0 / 4.5	110.0 / 7.5	77.0 / 7.5	112.0 / 7.5	93.0 / 5.5	89.0 / 5.5
DR976	84.0 / 4.0	110.0 / 7.0	77.0 / 7.0	112.0 / 7.0	93.0 / 5.0	89.0 / 5.0

Semboller :

Symbols :

Symbole :



:Yağ doldurma

:Oil filling

:Ölfüllung



:Yağ boşaltma

:Drain plug

:Ölauslass



:Yağ seviyesi

:Oil level

:Ölstand



:Havalandırma

:Vent Plug

:Entlüftungsschraube

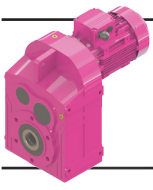

# Genel Bilgiler

## General Information

### Einführung



#### MOTORLAR

##### AC Motorlar

##### a- Genel Özellikler:

Basit konstrüksiyonlu, bakım gerektirmez, güvenilirliği yüksek ve uygun fiyatlı olmaları nedeni ile trifaze asenkron motorlar en çok kullanılan motor cinsidir. Bu motorların çalışma karakteristikleri moment-hız eğrisi ile belirlenir. Aşağıda bu karakteristik eğrisine bir örnek verilmiştir.

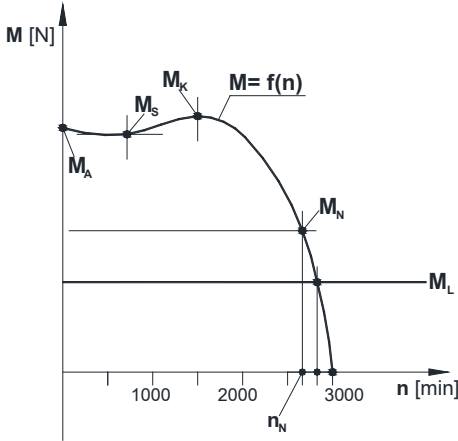

Motorun her start yapılmasında bu eğriye uygun hareket eder ve yük momentini  $M_L$  ile bu eğrinin çakıştığı noktada, motorun çalışma anındaki moment ve devirini verir.

Statorun manyetik alanı senkron hızla  $n_s$  döner. Kutuplar arasındaki faz kayması 3 fazlı motorlarda  $120^\circ$  'dir.

$$n_s = 120 \times \frac{f}{p_s}$$

f.....: şebeke frekansı [Hz]  
p\_s.....: statorun kutup sayısı

Rotorun değişken manyetik alanı rotorun statorun manyetik alanının dönüşü yönünde dönmeye başlamasını sağlar. Rotor bu hareketinde statorun manyetik alanını takip eder ama hiçbir zaman yakalayamaz. Rotor statorun manyetik alanının hızından yavaş döner. Rotorun bu hızına baz hız  $n_N$  denir. Yükün azalması rotorun hızının artmasını sağlar, aynı zamanda sapma azalmış olur. Sapma aşağıdaki gibi belirlenmiştir:

$$s = \frac{n_s - n_N}{n_s} \times 100$$

Sapmanın miktarına göre motorun nominal değerlerinde şu farklılıklar olabilir.

Sapma s .....:  $\pm 20\%$   
Kalkış Akımı.....:  $\pm 20\%$   
Kalkış Momenti.....:  $-15 / +25 \%$   
Kütle Atalet Momenti.....:  $\pm 10\%$   
Verim (37 kW'a kadar).....:  $-0,15 (1-\eta)$

#### MOTORS

##### AC Motors

##### a- General Specifications:

On account of its simple and maintenance free construction, good reliability and price, the three phase squirrel cage motor is one of the most frequently employed electric motors. The run up behavior of a three phase squirrel cage motor is described by the torque-speed characteristic curve. An example is shown below.

$M_A$ : Start moment / Starting torque / Anlaufmoment

$M_S$ : Demeraj moment / Pull-up torque / Anziehungsmoment

$M_K$ : Frenleme moment / Pull-out torque / Bremsungsmoment

$M_N$ : Motorun ilettiği moment / Motor rated torque / Treibmoment

$M_L$ : Yük moment / Load torque / Lastmoment

The motor follows this torque characteristics up to its stable operating point every time, when it is switched on. Operating point is that point, where the moment speed curve intersects with load torque  $M_L$  line.

The magnetic field in the stator rotates at a synchronous speed  $n_s$ . Phase shift of each pole is  $120^\circ$  at 3 phase motors.

$$n_s = 120 \times \frac{f}{p_s}$$

f.....: supply frequency [Hz]  
p\_s.....: number of stator poles

Because of the alternating magnetic field in the rotor, the rotor starts running in the same direction of the stator flux and tries to catch up with the rotating flux. The rotor never catches up the stator field. The rotor runs slower than the speed of the stator field. This speed is called the base speed  $n_N$ .

A decrease in load will cause the rotor to speed up or decrease slip. The slip is defined as follows:

$$s = \frac{n_s - n_N}{n_s} \times 100$$

According to the slip, the nominal values of the electric motor can alter as follows:

Slip s .....:  $\pm 20\%$   
Starting current .....:  $\pm 20\%$   
Starting torque .....:  $-15 / +25 \%$   
Moment of inertia.....:  $\pm 10\%$   
Efficiency (up to 37 kW).....:  $-0,15 (1-\eta)$

#### MOTOREN

##### Drehstrommotoren:

##### a- Allgemeine Eigenschaften

Wegen die wartungsarme und leichte Konstruktion, hohe Sicherheit bei Nutzung und günstige Preise werden die asynchrone Drehstrommotoren am meisten benutzt. Motoranlaufverhalten wird mit Moment-Drehzahl-Kurve charakterisiert. Ein Beispiel ist unten angegeben.

Der Drehstrommotor läuft diese Kurve bei jeder Anlauf, bis dem stabilen Betriebspunkt erreicht wird. Betriebspunkt ist der Zustand, bei dem die Moment-Drehzahl-Kurve sich mit der Linie von erforderlichen Moment  $M_L$  schneidet.

Magnetisches Feld von Stator dreht sich mit synchroner Geschwindigkeit  $n_s$ . Phasenverschiebung von den Polen ist  $120^\circ$  bei 3phasigen Drehstrommotoren.

$$n_s = 120 \times \frac{f}{p_s}$$

f.....: Frequenz der Spannung [Hz]  
p\_s.....: Anzahl der Polen von Stator

Durch das magnetische Wechselfeld in den Rotor, beginnt der Rotor sich in der gleichen Richtung des Statorflusses zu drehen und versucht diese Bewegung aufzuholen. Der Rotor kann den Statorfeld nie aufholen. Die Rotorgeschwindigkeit nennt man Basisgeschwindigkeit  $n_N$ . Eine Abnahme der Belastung bewirkt, dass der Rotor sich beschleunigt und der Schlupf sich verringert. Der Schlupf wird wie folgt definiert:

$$s = \frac{n_s - n_N}{n_s} \times 100$$

Für die nominale Werte der Drehstrommotoren sind folgende Abweichungen zulässig:

Schlupf s .....:  $\pm 20\%$   
Anzugsstrom .....:  $\pm 20\%$   
Anzugsmoment .....:  $-15 / +25 \%$   
Massentägheitsmoment .....:  $\pm 10\%$   
Wirkungsgrad (bis 37 kW).....:  $-0,15 (1-\eta)$

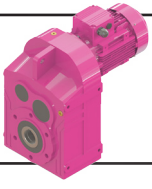

# Genel Bilgiler

## General Information

### Einführung



#### b- Çalışma Türleri

Katalogta verilen tüm redüktörlerin motorları S1 çalışma türüne uygun verilmektedir. Diğer çalışma türleri aşağıdaki tabloda gösterilmiştir.

#### b-Modes of Operation

All motors of the catalogue have been laid out for duty S1 (continuous operation). Other duty types are given on the following table.

#### b-Betriebsarten

Die im Katalog angeführten Motoren sind für Betriebsart S1 (Dauerbetrieb) ausgelegt. Andere Betriebsarten sind unten angegeben.

Çalışma Türü Operation Betriebsarten	Açıklama Explanation Erläuterung	Yük Grafiği Load Graphic Lastverläufe
S1	<b>Sabit yükte sürekli çalışma</b> <i>Continuous operation under constant load</i> Dauerbetrieb mit konstanter Belastung	
S2	<b>Sabit yükte kısa süreli çalışma</b> <i>Short-time duty under constant load</i> Kurzbetrieb mit konstanter Belastung	
S3	<b>Yolvermede sıcaklık artımı olmadan periyodik çalışma</b> <i>Periodic duty without influence of start-up on temperature</i> Aussetzbetrieb ohne Einfluß des Anlaufes auf die Temperatur	
S4	<b>Yolvermede sıcaklık artımı olan periyodik çalışma</b> <i>Periodic duty with influence of start up on temperature</i> Aussetzbetrieb mit Einfluß des Anlaufes auf die Temperatur	
S5	<b>Yolvermede ve frenlemede sıcaklık artımlı periyodik çalışma</b> <i>Periodic duty with influence of startup and braking on temp.</i> Aussetzbetrieb mit Einfluß des Anlaufes / Bremsung auf die Temp.	
S6	<b>Sürekli orta darbeleri çalışma</b> <i>Continuous operation with intermittent loading</i> Durchlaufbetrieb mit Ausetzungsbelastung	
S7	<b>Elektriksel frenlemeli sürekli orta darbeleri çalışma</b> <i>Continuous operation with intermittent loading and braking</i> Ununterbrochener Betrieb mit Anlauf und Bremsung	
S8	<b>Devir ve yük değişimli sürekli çalışma</b> <i>Continuous operation duty type with related load-speed changes</i> Ununterbrochener periodischer Betrieb mit Drehzahländerung	

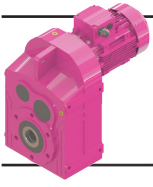

# Genel Bilgiler

## General Information

### Einführung



#### c- Koruma Sınıfı:

Yılmaz Redüktörde standart olarak IP54 (IEC 34-5) koruma sınıfı motorlar kullanılmaktadır. Diğer koruma sınıfları istendiğinde firmamıza danışınız.

#### d- İzolasyon Sınıfı:

Yılmaz Redüktörde kullanılan standart izolasyon sınıfı F (IEC 317-8) dir. İstek üzerine H sınıfı yapılabilmektedir.

#### e- Verim Sınıfları:

Üç fazlı az gerilim asenkron motorların verim sınıfı ölçümü IEC 60034-2-1:2007 normu ile belirlenmiştir. Yeni IE verim sınıfı 0,75 kW'tan 375 kW'a kadar güç aralığında çalışan AC motorlar için geçerlidir. EFF verim sınıfından farklı olarak IE verim sınıfı 6 kutup sayılı motorlar içinde kullanılabilir. Aşağıda verim sınıfları sıralanmıştır. Bölgeler dışında verim sınıfı zorunlulukları ülkelere göre farklılık gösterebilir. Lütfen firmamıza danışınız. Başka ürünlere entegre olmuş ve bu nedenle motorun veriminin bağımsız belirlenemediği sistemlerde (redüktör pompa gibi) verim sınıflandırması geçerli değildir.

#### c- Protection Class:

Yılmaz Redüktör uses IP54 (IEC 34-5) protection class electric motors for standard products. If different kind of protection class is requested please contact us.

#### d- Insulation Class:

Yılmaz Redüktör uses F (IEC 317-8) insulation class electric motors for standard products. H insulation class is available upon request.

#### e- Efficiency Classes:

The method for measuring the efficiency of low voltage three-phase asynchronous motors was revised with the new IEC 60034-2-1:2007 standard. The new IE classes is valid for AC Motors in power range from 0,75 to 375 kW. Unlike the EFF classes IE classes can be used for 6-pole AC motors. Below is the table of efficiency classes. The instructions for efficiency classes can differ from country to country. Please contact with us for more information. For the motors, which are fully integrated into a product (for example gear, pump) so their energy efficiency can not be recognized independently, the requirements of efficiency are not valid in Europe.

#### c- Schutzarten:

Yılmaz Redüktör Getriebemotoren werden serienmäßig mit Schutzart IP54 (IEC34-5) ausgeführt. Für andere Schutzarten bitte rückfragen.

#### d- Isolationsklasse:

Yılmaz Redüktör Getriebemotoren werden serienmäßig in Wärmeklasse F (IEC317-8) ausgeführt. H Wärmeklasse ist möglich auf Kundenwunsch.

#### e- Energieeffizienzklassen:

Die Methode für Messung die Effizienz von drei phasigen gering Spannung Asynchronmotoren hat neu mit IEC 60034-2-1:2007 Norm festgestellt. Die neue IE-Klassen gelten für alle Drehstrommotoren im Leistungsbereich von 0,75 bis 375 kW. Anders als EFF-Klassen die IE-Klassen können auch für 6-polige Drehstrommotoren verwendet werden. Unten steht die Tabelle der Effizienzklassen. Die Richtlinien für Effizienzklassen können sich je nach dem Land unterscheiden. Bitte mit unserem Firma Kontakt aufnehmen. Für die Motoren, die vollständig in ein Produkt (zum Beispiel Getriebe, Pumpe) eingebaut sind und deren Energieeffizienz nicht unabhängig von diesem Produkt erfasst werden kann, gelten in Europa die Anforderungen der Effizienzklassen nicht.

Verim Sınıfları Efficiency Classes Energieeffizienzklassen			4 Kutuplu Motor Verim Değeri Hesabı Calculating Efficiency Values of Motors with 4 Poles Berechnung der Wirkungsgrade von Elektromotoren mit 4 Polen	
IE1	EFF 2	<b>Standart Verim</b> Standart Efficiency Standarte Energieeffizienz	A=0,5234 B=-5,0499 C=17,4180 D=74,3171	$\eta_{Mn} = A \times [\log_{10}(P_L)] + B \times [\log_{10}(P_L)]^2 + C \times \log_{10}(P_L) + D$ <p><math>P_L</math> :Anma Yüğü [kW] / Nominal Load [kW] / Nennlast [kW]</p> <p><math>\eta_{Mn}</math> :Nominal verim / Nominal Efficiency [kW] / Sollwirkungsgrad</p>
IE2	EFF 1	<b>Yüksek Verim</b> High Efficiency Hohe Energieeffizienz	A=0,0278 B=-1,9247 C=10,4395 D=80,9761	
IE3	-	<b>Premium Verim</b> Premium Efficiency Premium Energieeffizienz	A=0,0773 B=-1,8951 C=9,2984 D=83,7025	
IE4	-	<b>Süper Premium Verim</b> Super Premium Efficiency Super Premium Energieeffizienz	-	

4 Kutuplu Motor Verim Değeri Efficiency Values of Motor with 4 poles Sollwirkungsgrad des Motors mit 4 Polen	Anma Yüğü [kW] Nominal Load [kW] Nennlast [kW]	Verim Sınıfı / Efficiency Class / Energieeffizienzklasse		
		IE1	IE2	IE3
	0,75	72,1 %	79,6 %	82,5 %
	1,5	77,2 %	82,8 %	85,3 %
	3	81,5 %	85,5 %	87,7 %
	7,5	86 %	88,7 %	90,4 %
	15	88,7 %	90,6 %	92,1 %
	22	89,9 %	91,6 %	93 %
	37	91,2 %	92,7 %	93,9 %
	45	91,7 %	93,1 %	94,2 %
	75	92,7 %	94 %	95 %
	90	93 %	94,2 %	95,2 %
	330	94 %	95,1 %	96 %

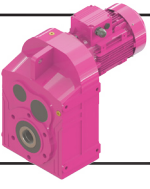

# Genel Bilgiler General Information Einführung



## f- AC Frekans İnvörtörler

Doğru Akımı (DC), alternatif akıma (AC) çeviren elektronik çeviricilere İnvörtör denilmektedir. AC motorlar için elektronik hız kontrol cihazları genellikle AC giriş akımını doğrultucu diyotlarla DC akıma çevirir ve daha sonra çevirici diyotlar vasıtası ile bu akımı tekrar AC akıma çevirir. Doğrultucu diyotlar ile çevirici diyotlar arasındaki bağlantı DC-bağ olarak tanımlanmaktadır. DC kontrol cihazının (genellikle İnvörtör olarak isimlendirilir) elektriksel blok şeması aşağıda verilmiştir.

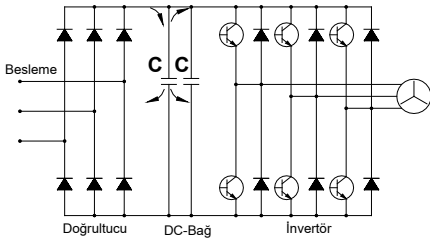

Tam dalga doğrultucuları besleyen üç faz besleme akımı DC-bağ kapasitörlerine iletilir. Kapasitörler voltajdaki dalgalanmaları azaltır ve kısa süreli ağıdaki akım kesintilerinde enerji sağlar. Kapasitörlerdeki voltaj kontrolsüzdür ve gelen AC akımın pik akım değerlerine bağlıdır. DC akım tekrar AC akıma, Puls genişliği modülasyonu (PWM) kullanılarak çevrilir. İstenen dalga formu, sabit bir frekansta (Puls frekansında), çıkış transistörlerinin (İzole edilmiş geçit Bipolar transistörleri; IGBT 'ler) açılıp kapatılması ile oluşturulur. IGBT'lerin açma kapama zamanlarının değişimi ile istenen akım oluşturulabilir. Çıkış voltajı bir seri kare dalga pulslardır ve motor sargılarının İndüktansı ile sinusoidal bir motor akımı oluşur. Puls genişliği modülasyonu aşağıda gösterilmiştir.

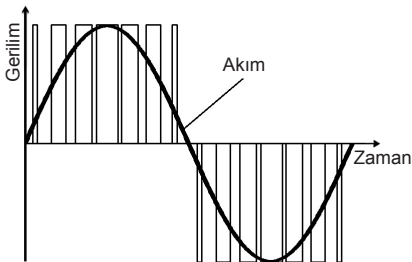

## f- AC Frequency Inverters

An electronic converter is a device which converts Direct Current (DC) to Alternating Current (AC) is known as an inverter. Electronic speed controllers for AC motors usually convert the AC supply to DC using a rectifier, and then convert it back to a variable frequency, variable voltage AC supply using an inverter bridge. The connection between the rectifier and inverter is called the DC link. The block diagram of a speed controller (often called an inverter) is shown below.

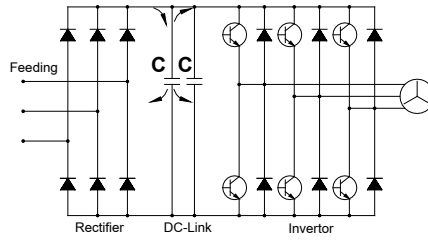

The three phase supply is fed into a full wave rectifier which supplies the DC link capacitors. The capacitors reduce the voltage ripple (especially on single supplies) and supply energy for short mains breaks. The voltage on the capacitors is uncontrolled and depends on the peak AC supply voltage. The DC voltage is converted back to AC using Pulse Width Modulation (PWM). The desired waveform is built up by switching the output transistors (Insulated Gate Bipolar Transistors; IGBTs) on and off at a fixed frequency (the switching frequency). By varying the on and off time of the IGBTs the desired current can be generated. The output voltage is still a series of square wave pulses and the inductance of the motor windings results in a sinusoidal motor current. Pulse Width Modulation is shown in the figure below.

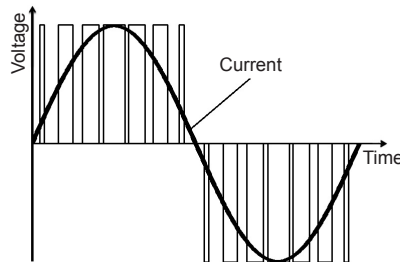

## f- AC Frequenz Umrichter

Ein elektronischer Wandler, der den Gleichstrom (DC) in Wechselstrom (AC) umwandelt, wird als Umrichter bezeichnet. Ein Frequenzumrichter benutzt einen ungesteuerten Eingangsgleichrichter, um die Netzspannung in Gleichspannung umzuwandeln. Diese wird dann in den Zwischenkreiskondensatoren gespeichert. An diesem Gleichspannungszwischenkreis ist ein Wechselrichter angeschlossen. Dieser Wechselrichter erzeugt am Ausgang eine variable Frequenz und eine variable Spannung. Der Anschluss zwischen dem Gleichrichter und dem Wechselrichter nennt man Gleichstromverbindung. Das Blockschaltbild von diesem System wurde unten dargestellt:

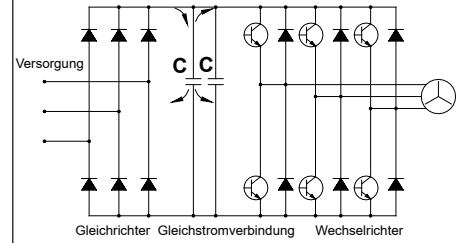

Auch bei dreiphasiger Versorgung wird die gleichrichtete Netzspannung den Zwischenkreiskondensatoren zugeführt. Die Kondensatoren reduzieren die Oberwelligkeit der Spannung (was besonders bei einphasiger Versorgung entscheidend ist) und liefern Energie, die kurze Unterbrechungen der Netzstromversorgung ermöglicht. Die Spannung der Kondensatoren ist vom Spitzenwert der Wechselspannung abhängig. Die Gleichspannung wird im Wechselrichter durch Pulsweitenmodulation (PWM) in Wechselspannung umgewandelt. Die gewünschte Wellenform wird durch Ein- und Ausschalten der Ausgangstransistoren (IGBT's Isolierte Gate Bipolar Transistoren) mit einer festen Frequenz (der Pulsfrequenz) erzeugt. Der gewünschte Strom kann durch die Variation der Ein- und Ausschaltzeit der Ausgangstransistoren generiert werden. Die Ausgangsspannung ist dadurch eine Reihe von Spannungsimpulsen, die in Verbindung mit der Induktivität der Motorspulen zu einem sinusförmigen Motorstrom führt. Die Pulsweitenmodulation wird wie folgt dargestellt

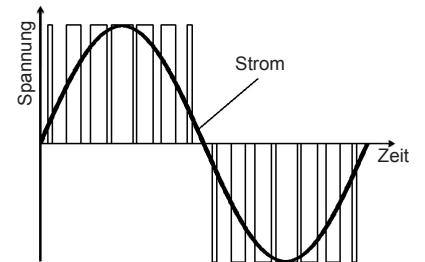

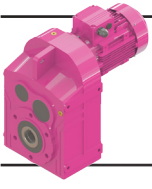

# Genel Bilgiler

## General Information

### Einführung



#### DC MOTORLAR

##### a- Genel Özellikler

DC motorlar, elektronik parçalardaki gelişmeler nedeni ile yeni uygulama alanları bulmuştur. Daha önce çok pahalı olan ve ekonomik olmayan kontrol sistemlerinin yerini ucuz ve kompakt güç kontrol üniteleri almıştır. Yol vermenin kontrol altına alınabildiği, tork ve akım izlenebilirliği, aşırı yüklenmeye karşı elektronik koruma sağlanabilmesi ve daha birçok pahalı olmayan uygulamalar DC motorlarını cazip kılmaya başlamıştır.

##### b- DC Motorların Çalışma İlkeleri

DC motorlar için DC çıkış veren bir doğrultucuya ihtiyaç vardır. Motor armatür sargıları, alan sargıları, komutasyon sargıları ve kompanse sargılar olmak üzere rotorda ve statorda bulunan sargılardan oluşur. Rotora voltaj ve akım karbon fırçalar ve komutator sargılarla ulaştırılır. Bu karbon fırçalar aşındığından DC motorlar belirli periyotlarla bakıma alınmalıdır. İyi kontrol edilebilir özelliklerinden dolayı DC motorlar otomasyon teknolojisinde sıkça kullanılmaktadır.

##### c- DC Motor Çeşitleri

Temel olarak Şönt (Shunt) ve seri sargılı DC motorlar bulunmaktadır. Bu sargıların çeşidine göre moment eğrisi değişmektedir.

##### d- DC Motorlarda Hız Kontrolü

Bu motorlarda devir değişimi DC voltajın değiştirilmesi ile yapılır. Şönt sarımlı DC motorların sıfır yük ile maximum yük arasındaki davranışı AC motorlara benzer. Devir artan yükte beraber düşer. Bu devir farkı ufak güçlü motorlarda büyük, büyük güçlü motorlarda ise ufaktır. Fakat bu hız farkı DC doğrultucu cihazda armatür voltajı ( $I \times R$ ) ile oynanarak kompanse edilebilir. Hassas hız kontrol gereksinimi olduğunda, tako jeneratörler kullanılabilir. DC motorların gücü aşağıdaki formülden hesaplanır;

$$P_g = U \times I = \frac{P_c}{\eta}$$

$P_g$  : Giriş gücü W  
 $P_c$  : Çıkış gücü W  
U : Armatür gerilimi V  
I : Armatür akımı A  
 $\eta$  : Motor verimi

#### DC MOTORS

##### a- General Specifications of DC Motors

DC drive systems have found new possible applications with the development of the electronic components sector. What was previously extremely expensive and in some cases not economically feasible is nowadays realized by miniaturised power converter technology. Additional functions such as guided startup after a predetermined time, torque and current monitoring with electronic protection against overloading, and many inexpensive special applications have made DC drive systems more attractive.

##### b- Operating principles of the DC Motors

The DC motor requires, a converter with DC output. The motor includes windings, such as armature, field, commutation and compensation windings, which are arranged in the stator as well as on rotor. Voltage and current are supplied to the rotor via the carbon brushes and the commutator. The carbon brushes are wearing parts therefore a DC motor requires maintenance at service intervals. While its good control properties, the DC motor is an essential item in automation technology.

##### c- Types of DC Motors

Depending on the wiring of the exciting winding or field winding, two basically different variants are regards torque speed characteristics may be distinguished.

##### d- Speed Control of DC motors

In DC motors the speed is adjusted by altering the DC voltage. DC shunt wounded motors behave similar to three phase induction motors between no load operation and maximum load. The speed drops with increasing loading of the motor. This difference is greater in small motors and smaller in larger motors. The speed difference can be compensated in the DC converter device by adjusting ( $I \times R$ ). If great control accuracy is required, a speed control with measurement of the actual values by a tachogenerator can be used. The power of DC motor;

$$P_g = U \times I = \frac{P_c}{\eta}$$

$P_g$  : Input Power W  
 $P_c$  : Output Power W  
U : Armature Voltage V  
I : Armature Current A  
 $\eta$  : Motor efficiency

#### DC MOTOREN

##### a- Eigenschaften von DC Motoren

Mit den Entwicklungen bei elektronischen Komponenten haben DC Motoren neue Anwendungsbereiche gefunden. Regelungssysteme, die früher sehr teuer und im manchen Anwendungsfällen ungünstig waren, sind jetzt kompakt und günstig. Bei den DC Motoren ist kontrolliertes Anlauf, Moment- und Stromüberwachung mit Überlastschutz möglich. Es gibt viele günstige Sonderanwendungen für diese Motoren. Wegen oben genannten Eigenschaften werden die DC Motoren immer mehr bei unterschiedlichen Anwendungen benutzt.

##### b- Funktionsprinzip der DC Motoren

Bei DC Motoren ist eine Kommutatorwicklung im Rotor angeordnet, während der magnetische Fluss vom Stator erzeugt wird. Dies kann wiederum mittels einer Erregerwicklung oder durch Permanentmagnete geschehen. Wie bei der Synchronmaschine wird durch das Erregerfeld in der Ankerwicklung eine Wechselfeldspannung, die bei der Gleichstrommaschine jedoch durch den mechanischen Kommutator und die darauf schleifenden Bürsten in eine Gleichspannung umgeformt wird, induziert.

##### c- Arten von DC Motoren

Es gibt zwei verschiedene Wicklungen, nämlich Shunt- und Serial-Wicklung. Das Drehmoment-Drehzahl-Verhältnis ist für beide Wicklungen unterschiedlich.

##### d- Drehzahl Kontrolle für DC Motoren

Drehzahl von DC Motoren kann man mit Steuerung der DC Spannung ändern. DC Motoren mit Shunt Wicklungen ist ähnlich zu drei phasen AC Motoren zwischen maximalen Last und ohne Last. Drehzahl wird mit der Last reduziert. Mit kleineren Motoren wird dieser Differenz höher mit größeren Motoren kleiner. Der Drehzahlunterschied kann geregelt werden mit ( $I \times R$ ) Veränderung. Wenn eine genaue Kontrolle gebraucht, soll ein Tachogenerator benutzt werden. Leistung des DC Motors;

$$P_g = U \times I = \frac{P_c}{\eta}$$

$P_g$  : Eingangsleistung W  
 $P_c$  : Ausgangsleistung W  
U : Ankerspannung V  
I : Ankerstrom A  
 $\eta$  : Wirkungsgrad des Motors

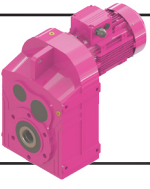

# Genel Bilgiler

## General Information

### Einführung



#### Elektromanyetik Frenler

Bu tip frenlerin iki sürtünme yüzeyi vardır. Fren torku, voltaj uygulanmadığı zaman yayların kuvveti ile oluşturulur. Fren elektromanyetik alanın oluşumu ile serbest kalır. Bobinin beslenmesi ile mıknatıslanan balata baskı pulu, elektromıknatısa doğru çekilir. Bu hareket yayları baskı altına alır ve rotor mili üzerine takılan çoklu kama üzerinde aksiyal yönde serbest hareket edebilen balata serbest kalır. Akım kesildiğinde yayların baskısıyla, balata baskı pulu fren balatasına doğru itilir ve bu hareket rotoru frenler.

#### Fren Çeşitleri

##### a) Soğutmasız tip frenler

Motor fanı çıkarılıp motor kapağı arkasına akup-  
le edilerek kullanılan frenler; genellikle sıkça  
açılıp kapanmayan ve kısa zaman aralıklarında  
çalışan sistemlerde tercih edilir.

##### b) Soğutmalı tip frenler

Motor fanı çıkarılıp motor kapağı arkasına  
akuple edilen ve motorun mili uzatılarak fren  
ve motorun arkasına alınan fan sayesinde da-  
imi bir hava sirkülasyonu sağlanarak kullanılan  
frenlerdir. Genellikle uzun süreli çalışan ve  
kapalı mekanlarda kullanılan sistemlerde tercih  
edilirler.

##### c) Manuel kol sistemli frenler

Çalışma sistemi olarak her iki fren tipinde de  
kullanılabilir (soğutmalı veya soğutmasız).  
Özel durumlarda (elektrik kesilmesi; mekanik  
problemler) üzerinde bulunan bir kol vasıtası  
ile sistemi yay baskısından kurtararak serbest  
kalmasını sağlayan frenlerdir. Genellikle ma-  
nuel olarak sistemin açılması gereken yerlerde  
(otomatik giriş kapıları, dış cepe boyama asan-  
sörleri v.b.) tercih edilir.

#### Fren çalışma voltajları

Elektromanyetik frenler 230V AC veya 400V AC  
beslemeli olarak sipariş edilebilir. Frenler DC  
fren olmaları nedeni ile besleme ile fren bobini  
arasında fren tipine bağlı olarak, yarım dalga,  
tam dalga doğrultucular veya trafolar kullanılır.  
Özel olarak belirtilmedikçe 230V beslemeli ve  
yarım dalga doğrultuculu frenler kullanılmak-  
tadır. Özel durumlar için YILMAZ Redüktöre  
danışınız.

##### a) 230V AC ile beslenen frenler

Motor klemens kutusundan alınan 230V'luk AC  
besleme fren tipine bağlı olarak yarım dalga  
veya tam dalga doğrultucu ile fren bobininin  
voltajına düşürülür. Fren bobin DC voltajı etiketi  
üzerinde belirtilmiştir.

##### b) 400V AC ile beslenen DC frenler

Motor klemens kutusundan alınan 400V'luk AC  
besleme, yarım dalga doğrultucu ile fren bobini-  
nin voltajına düşürülür. Fren bobininin DC voltajı  
etiket üzerinde belirtilmiştir.

##### c) 24V DC Frenler

Kullanılan fren momentinin büyüklüğüne göre  
besleme transformatörü seçilir. Şebekeden  
veya motorun klemens kutusundan alınan bes-  
leme voltajı transformatörde 29 V'a çevrilen ge-  
rilim tam dalga doğrultuculardan geçerek 24V  
DC'ye çevrilir ve fren bobini beslenir.

#### Electromagnetic Brakes

*This type of brakes has two friction surfaces. Brake torque is generated by springs when no voltage is applied. The brake is electromagnetically released. On exciting the electromagnet means of the current, the armature plate is pulled towards the electromagnet itself, thrust loading the pressure spring and enabling the friction disc which is axially movable on the key, to turn freely. When current fails, the pressured springs drive the armature plate towards the disc, thus braking the motor shaft.*

#### Brake Types

##### a) Brakes without cooling

*This type of brakes are assembled on the back cover of the electric motor. There is no fan on the backside. This brake type is mostly preferred in short working times and short working cycles.*

##### b) Fan cooled brakes

*This type of brakes are assembled on the back cover of electric motor by removing the electric motor fan. A fan is coupled to the backside of the brake by extending the rotor shaft of the electric motor. Fan cooled brakes are preferred in long working times and closed places without airflow.*

##### c) Brakes with hand release

*This brakes can be released by help of an arm. It can be applied to both of the above mentioned brakes and used in special cases (fail of electric current, mechanical problems etc.) These brakes are mostly preferred if operation (re-lasing) without a current is needed (automatic controlled doors, gates, building wall painting elevators etc.).*

#### Working Voltages

*Electromagnetic brakes can be ordered with 230V AC or 400V AC supply voltage. The coil of brakes needs DC voltage and therefore depending on brake type a half wave, a full wave rectifier or transformer should be used between supply and coil voltage. As standard the brakes will be delivered with 230V supply voltage and half wave rectifier, if there is no special request. For special cases please contact YILMAZ Redüktör.*

##### a) Brakes with 230V supply voltage

*230V AC supply voltage from the motor terminal box will be reduced to the coil voltage depending on the brake type with half-wave or full-wave rectifier. DC brake coil voltage is indicated on the label.*

##### b) Brakes with 400V supply voltage

*400V AC supply voltage from the motor terminal box will be reduced to the coil voltage with half-wave rectifier. DC brake coil voltage indicated on the label.*

##### c) 24V DC Brakes

*The transformer's size is selected according to value of brake torque. The current is taken from the electric motor terminal box or from the electric panel and is transformed to 29V DC current. This current is transferred to 24V DC current with full-wave rectifier and supplies brake coil.*

#### Elektromagnetische Bremsen

Die Bremse hat zwei Reibflächen und arbeitet nach dem Ruhestromprinzip. Im stromlosen Zustand wird das Bremsmoment durch den Druck der Feder erzeugt, während die Bremse beim Betrieb elektromagnetisch losgelassen wird. Durch die Erregung der Elektromagneten wird die Ankerscheibe zu den Elektromagneten gezogen und die Feder zusammengedrückt. Dadurch kann sich die Bremscheibe, die axial beweglich auf dem Mitnehmer angeordnet ist, frei drehen. Wird der Strom unterbrochen, drücken die Feder die Ankerscheibe gegen die Bremscheibe und halten die Motorwelle an.

#### Bremsearten:

##### a) Bremsen ohne Kühlung

Diese Bremsen sind für Kurzlaufzeiten geeig-  
net. Die Lüfterhaube und Lüfter des Motors ist  
ausgebaut und die Bremse ist an dem Ende der  
Motorwelle befestigt.

##### b) Bremsen mit Kühlung

Diese Bremsen sind für lange Laufzeiten und  
kleine, abgedeckte Räume geeignet. Durch  
die Verlängerung der Motorwelle wurde Lüfter  
hinter dem Bremse und dem Motor verbunden.  
Somit wurde eine konstante Lüftung ermöglicht.

##### c) Bremsen mit Hebelarm

Diese Bremsenart kann mit oder ohne Kühlung  
verwendet werden. Diese Bremsen sind bei  
der speziellen Fälle, wie keine Spannung an  
der Leitung, mechanische Probleme usw., an-  
wendbar. Die Bremse wird mit einem Hebelarm  
manuell betätigt. Diese Bremsen werden am  
meisten an den Stellen, wo die Lüftung ohne  
Spannung erfolgen soll, benutzt (automatische  
Türe, Wandaufzüge).

#### Betriebsspannungen

Elektromagnetische Bremsen können mit 230V  
AC oder 400V AC Versorgungsspannung be-  
stellt werden. Die Wicklungen der Bremsen  
brauchen Gleichspannung und deswegen  
abhängig von Bremsenart zwischen Versor-  
gungsspannung und Wicklungsspannung soll  
Halbwellen-, Vollweggleichrichter oder Trans-  
formator verwendet werden. Als Standard die  
Bremsen werden mit 230V Versorgungsspan-  
nung und Halbwellengleichrichter geliefert.

##### a) Bremsen mit 230V Versorgungsspannung

230V AC Versorgungsspannung von Klemmen-  
kasten wird auf die Wicklungsspannung abhän-  
gig von der Bremsentyp mit Halbwellen-oder  
Vollweggleichrichter reduziert. Wicklungsspan-  
nung ist auf dem Etikett angegeben.

##### b) Bremsen mit 400V Versorgungsspannung

400V AC Versorgungsspannung von Klemmen-  
kasten wird auf die Wicklungsspannung mit  
Halbwellengleichrichter reduziert. Wicklungs-  
spannung ist auf dem Etikett angegeben.

##### c) 24V DC Bremsen

Die Spannung wird von den Klemmkasten des  
Motors oder Elektrischschrank entnommen. Diese  
Spannung wird zuerst mittels Transformator zu  
24 V reduziert. Danach wird diese Spannung  
mit Hilfe von Gleichrichter zu Gleichstromspan-  
nung umgewandelt. Die Größe des Transfor-  
mators ist abhängig von der Größe des Brems-  
moments.

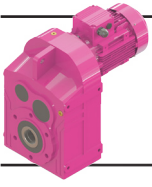

# Genel Bilgiler

## General Information

### Einführung



#### d) Şok ikazlı trafolar

Büyük güçteki ve momentteki frenlerin manyetik doyuma ulaşmaları uzun zaman alır. Şok ikazlı trafolar frenin yay baskısını yenmede gecikmesini engellemek için kullanılır ve zaman rölesi yardımı ile çok kısa bir süre normal besleme voltajının iki katı ile (48V DC) beslenip sistemin ani açılmasını sağlar. Bu sayede gecikmeli açılmada ortaya çıkacak sürtünmeyi engellemeye yarayan bir trafo şeklindedir.

#### Fren bağlantı şekli

##### a) Gecikmeli frenleme

Genellikle sistemin yavaş ve kaydırılarak durması gereken yerlerde tercih edilen bağlantı şeklidir. Vinç yürütme motorlarındaki sarsıntıyı önlemek için gecikmeli bağlantı şekli kullanılır. Frenler fabrika çıkışında gecikmeli bağlantıya uygun ayarlanır.

##### b) Ani frenleme

Genellikle sistemin enerjisi kesildiği anda ani olarak durdurulması gereken sistemlerde kullanılan bağlantı şeklidir. Vinç kaldırma sistemleri, asansör motorlarında kullanılan bağlantı şeklidir.

#### d) Shock voltage supply transformer

Brakes which consist of high power and torques take long time to get in electromagnetic field. Shock voltage supply transformers with time relay are aiming to overcome spring pressure delaying for brakes. Also this transformers provide to open system suddenly by feeding double(48V DC) voltage in a short time and preventing to frictional losses occurring in delayed opening.

#### Connection Types

##### a) Delayed Braking

Generally this type of connection uses in slow and sliding brake intended systems. Delayed connection type using to prevent shock loadings in crane driving systems. Brakes are setting up to delayed connection if any other types are not specified by customer

##### b) Sudden Braking

This type of connections are mostly used in systems when short braking times are needed. The braking torque will be produced as soon as the current fails. These brakes are mostly used in hoisting of lifting units and elevators.

#### d) Trafos mit Schock-Spannung

Diese Transformatoren werden bei großen Bremsen mit hohen Momenten verwendet. Da die große Bremsen eine lange Zeit braucht, um die erforderliche magnetische Feld zu erzeugen, wird an der Bremse kurz 48V Gleichstromspannung angelegt, um die Zeit zur Bildung von magnetischem Feld zu kürzen. Dies ermöglicht kürzere Reibungszeiten beim Start.

#### Schaltungsarten:

##### a) Verspätetes Bremsen

Diese Schaltung wird benutzt, wenn ein langsames und gleitendes Bremsen erforderlich ist. Am meisten wird es bei Fahrtriebmotoren von Aufzügen verwendet. Wenn keine Angabe bei der Bestellung gegeben wird, werden die Bremsen mit verspäteter Schaltung geliefert.

##### b) Schnelles Bremsen:

Allgemein verwendet man diese Schaltung bei Bedarf an plötzlichen Bremsen in dem Augenblick, in dem das System keine Energie mehr erhält. Diese Schaltungsart wird meist bei Kräne und Motoren von Aufzüge verwendet.

Geçikmeli Frenleme / Delayed Running Brake / Verspätete Bremsung  
(230 V)

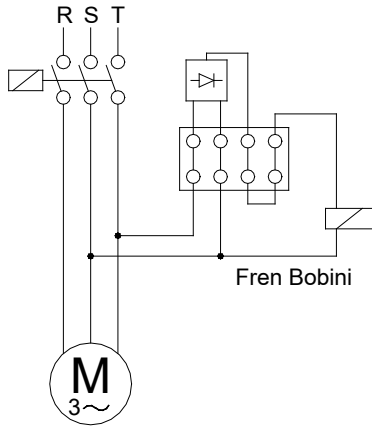

Ani Frenleme / Sudden Brake / Plötzliche Bremsung  
(230 V)

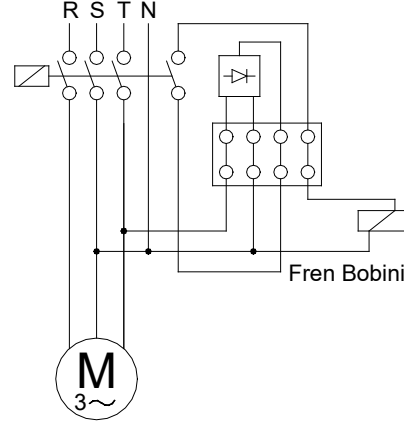

Geçikmeli Frenleme / Delayed Running Brake / Verspätete Bremsung  
(24 V)

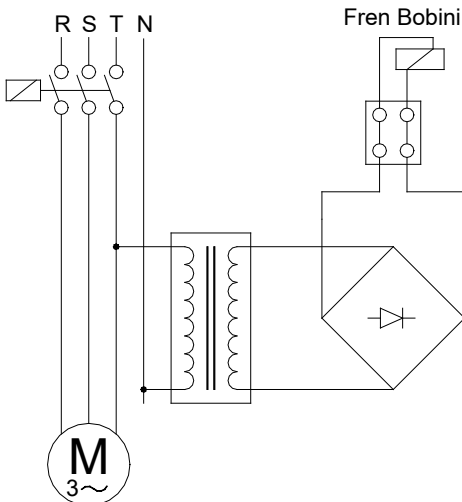

Ani Frenleme / Sudden Brake / Plötzliche Bremsung  
(24 V)

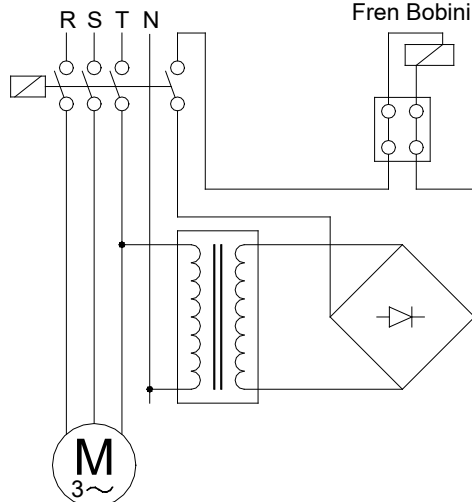

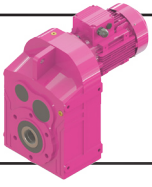

# Genel Bilgiler

## General Information

### Einführung



#### Fren Seçimi:

Doğru bir fren seçimi için aşağıdaki parametreler bilinmelidir.

- $I_{tot}$  [kg.m<sup>2</sup>] : Motor miline indirgenmiş toplam atalet momenti
- $n_0$  [d/dak] : Maksimum motor devir sayısı
- $t_f$  [s] : İstenilen en uzun frenleme zamanı
- $c_t$  : Anahtarın devreye girme zamanı katsayısı (ortalama 0,995).
- $M_L$  [Nm] : Sistemin statik tork ihtiyacı.
- $C_s$  : Emniyet katsayısı ( $C_s \geq 2$  olmalı)

Gerekli fren momenti aşağıdaki şekilde hesaplanır:

a)  $M_L$  Statik yük torku, motor dönüş yönünde (motorun dönüşüne yardımcı olarak, yükün indirilmesi veya hızlandırıcı sabit yük momenti hali):

$$M_{fc} = \frac{(2 \pi \times n_0 \div 60) \times I_{tot}}{t_f \times c_t} + M_L$$

b)  $M_L$  Statik yük torku, motor aksi dönüş yönünde (motorun dönüşüne engel olarak, yükün yukarı kaldırılması veya frenleyici sabit yük/direnç momenti hali):

$$M_{fc} = \frac{(2 \pi \times n_0 \div 60) \times I_{tot}}{t_f \times c_t} - M_L$$

Yukarıda bulunan sonuç  $C_s$  katsayısı ile çarpılarak ( $C_s \geq 2$ ), fren momenti seçilir;

$$M_f = M_{fc} \times C_s$$

#### Yaklaşım Yolu ile Fren Seçimi:

Eğer yalnızca motorun gücü ve en yüksek devri biliniyor ise :

W [Watt]: Motorun nominal gücü

$$M_f = \frac{W}{\frac{2\pi \times n_0}{60}} \times C_s \quad (C_s \geq 2)$$

#### Brake Selection:

To select a brake correctly the following data are necessary;

- $I_{tot}$  [kg . m<sup>2</sup>] : The total inertia of rotating parts reduced at the motor shaft
- $n_0$  [rpm] : Maximum motor speed.
- $t_f$  [s] : The maximum admitted time of the braking.
- $c_t$  : Coefficient of switch on time (average 0,995).
- $M_L$  [Nm] : Required static torque of system.
- $C_s$  : Safety coefficient ( $C_s \geq 2$ )

The necessary braking torque calculates below;

a) The static load torque  $M_L$ , same direction of motor rotation (Descent of a load or steady resisting torque which favours the rotation of the motor)

$$M_{fc} = \frac{(2 \pi \times n_0 \div 60) \times I_{tot}}{t_f \times c_t} + M_L$$

b) The static load torque  $M_L$ , opposes the rotation of the motor (Lifting of a load or steady resisting torque which opposes the rotation of the motor)

$$M_{fc} = \frac{(2 \pi \times n_0 \div 60) \times I_{tot}}{t_f \times c_t} - M_L$$

The necessary braking torque will result from the following equation using  $C_s$  ( $C_s \geq 2$ );

$$M_f = M_{fc} \times C_s$$

#### Approximated Brake Selection

Its only the motor power and its maximum speed are known:

W [Watt]: Motor Nominal Power

$$M_f = \frac{W}{\frac{2\pi \times n_0}{60}} \times C_s \quad (C_s \geq 2)$$

#### Bremswahl:

Um die richtige Bremse auszuwählen, braucht man unten aufgelistete Variablen;

- $I_{tot}$  [kg . m<sup>2</sup>] : Die Gesamtträgheit der rotierenden Teile (siehe Anwendungsbeispiele)
- $n_0$  [U/min] : Die höchste Drehzahl des Motors
- $t_f$  [s] : Die längste zulässige Bremszeit
- $c_t$  : Reduktionskoeffizient der Tätigkeitszeit (gemittelt 0,995).
- $M_L$  [Nm] : Vom system benötigtes, statisches Drehmoment.
- $C_s$  : Sicherheitskoeffizient ( $C_s \geq 2$ )

Die benötigte Bremskraft wird wie folgt berechnet:

a) konstantes Belastungsmoment  $M_L$ , das die Motordrehung fördert (konstante Erhöhung der Motorgeschwindigkeit oder Herunterlassen der Last)

$$M_{fc} = \frac{(2 \pi \times n_0 \div 60) \times I_{tot}}{t_f \times c_t} + M_L$$

b) konstantes Belastungsmoment  $M_L$ , das sich entgegen der Motordrehung widersetzt (konstante Verminderung der Motorgeschwindigkeit oder Aufheben der Last)

$$M_{fc} = \frac{(2 \pi \times n_0 \div 60) \times I_{tot}}{t_f \times c_t} - M_L$$

Wenn die Bremskraft mit dem Sicherheitskoeffizient  $C_s$  ( $C_s \geq 2$ ) multipliziert wird, erhält man die erforderliche Bremskraft;

$$M_f = M_{fc} \times C_s$$

#### Abschätzung zur Bremswahl

Wenn man nur die Motorleistung und die höchste Drehzahl kennt, kann die Bremskraft mit der folgenden Formel annähernd berechnet werden:  
W [Watt] : Nennleistung des Motors

$$M_f = \frac{W}{\frac{2\pi \times n_0}{60}} \times C_s \quad (C_s \geq 2)$$

#### Standart Frenler / Standard Brakes / Standart Bremsen

<b>Fren statik momenti [Nm]</b> Brake Static Torque [Nm] Statische Bremskraft [Nm]	4,5	8	12	16	35	60	80	150	200
<b>Fren Dinamik Momenti [Nm]</b> Brake Dynamic Torque [Nm] Dynamische Bremskraft [Nm]	3,6	6,4	9,6	12,8	28	48	64	120	160
<b>Maksimum Motor Hızı [d/dak]</b> Maximum Motor Speed [rpm] Maximale Motordrehzahl [U/min]	3000	3000	3000	3000	3000	3000	3000	1500	1500
<b>Giriş Gücü [W]</b> Input Power [W] Antriebsleistung [W]	15	20	25	30	45	50	55	60	65

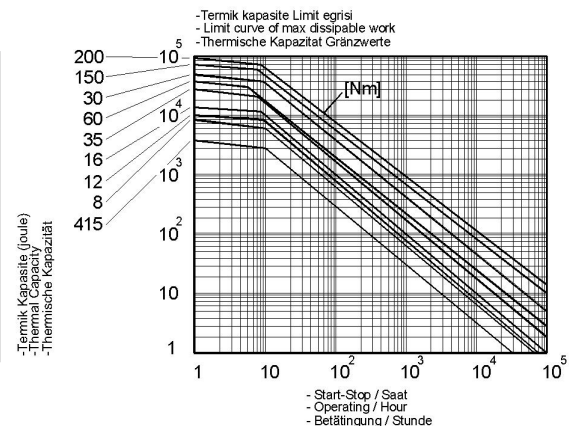

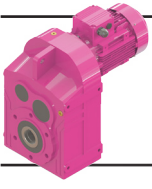

# Genel Bilgiler

## General Information

### Einführung



#### Frenin Termik Kapasitesi

Yukarıdaki seçime ek olarak frenin termik kapasitesinin kontrol edilmesi gerekir. L (joule) olarak gerekli soğutma işi aşağıdaki formüller ile hesaplanır ve "Termik kapasite limit eğrisi" kullanılarak eğrinin altında kalıp kalmadığı kontrol edilir.

a)  $M_L$  Statik yük torku motor dönüş yönünde (motorun dönüşüne yardımcı olarak, yükün indirilmesi hali)

$$L = \frac{I_{tot} \times (2\pi \times n_0 \div 60)^2}{2} \times \left( \frac{M_f}{M_f - M_L} \right)$$

b)  $M_L$  Statik yük torku motor aksi dönüş yönünde (motorun dönüşüne engel olarak, yükün kaldırılması hali):

$$L = \frac{I_{tot} \times (2\pi \times n_0 \div 60)^2}{2} \times \frac{M_f}{M_f + M_L}$$

c)  $M_L$  Statik yük torku sabit, motor yönünde veya aksi yönde (kaldırma ve indirme harici hızlandırıcı veya frenleyici sabit bir yük momenti hali).

$$L = \frac{I_{tot} \times (2\pi \times n_0 \div 60)^2}{2}$$

#### Fren Hava Boşluğunun Ayarı:

Frenden sürekli aynı performansın alınabilmesi için, fren balatasının aşınmasına bağlı olarak, fren hava boşluğu belirli zaman aralıklarında yeniden ayarlanmalıdır. Fren hava boşluğu ayar zaman aralığı ve ayarın yapılması için firmamıza danışınız.

#### Fren Seçim Örneği:

İstenilen en uzun frenleme zamanı: 0,5 sn.

Motor devri: 1400 d/dak

Motorla indirgenmiş toplam atalet momenti:

0,08 kgm<sup>2</sup>

Gerekli çalışma momenti: 50 Nm

Yük Durumu: Yük motor dönüş yönü ile aynı (Vinçten yük indirilmesi: Saatte dur-kalk sayısı:30)

$$M_{fc} = \frac{(2\pi \times 1400 \div 60)}{0,5 \times 0,995} + 50 = 73,6 \text{ Nm}$$

$$M_f = 73,6 \times 2 = 147,2 \text{ Nm}$$

Standart frenler tablosundan 150 Nm lik fren seçilebilir.

Gerekli termik kapasite:

$$L = \frac{0,08 \times (2\pi \times 1400 \div 60)^2}{2} \times \left( \frac{147,2}{147,2 - 50} \right)$$

=1302,0 < 18000 Joule (150 Nm eğrisinden)  
150 Nm lik fren uygun görülüyor.

#### The Thermal Capacity of Brake

The thermal capacity of the brake must also be checked after the above mentioned calculations. The heat dissipation energy L (joule) can be calculated from the following equation and must be checked if the result is under the limit curve shown on "Limit curve of may dissipable work".

a) The static load torque  $M_L$ , favours the rotation of the motor (Descent of a load which favours the rotation of the motor)

$$L = \frac{I_{tot} \times (2\pi \times n_0 \div 60)^2}{2} \times \left( \frac{M_f}{M_f - M_L} \right)$$

b) The static load torque  $M_L$ , opposes the rotation of the motor (Lifting of a load which opposes the rotation of the motor)

$$L = \frac{I_{tot} \times (2\pi \times n_0 \div 60)^2}{2} \times \frac{M_f}{M_f + M_L}$$

c) The static load torque  $M_L$ , is constant and opposes or favours the rotation of the motor (except lifting of a load)

$$L = \frac{I_{tot} \times (2\pi \times n_0 \div 60)^2}{2}$$

#### Adjustment of the air-gap:

In order to obtain the same performance from the brake during its lifetime, the air-gap of the brake must be re-adjusted after a limited time of operation. For the air-gap and the time interval of the adjustment please contact us.

#### Selection Example:

The maximum admitted time for braking 0,5 s

Motor speed: 1400 rpm

Total inertia reduced at motor shaft: 0,08 kgm<sup>2</sup>

Required operating torque: 50 Nm

Nature of load: Load direction is same as motor direction (Unloading process: Start-stop time per hour :30)

$$M_{fc} = \frac{(2\pi \times 1400 \div 60)}{0,5 \times 0,995} + 50 = 73,6 \text{ Nm}$$

$$M_f = 73,6 \times 2 = 147,2 \text{ Nm}$$

From the brake selection table a standard brake of 150 Nm is selected.

Necessary thermal capacity

$$L = \frac{0,08 \times (2\pi \times 1400 \div 60)^2}{2} \times \left( \frac{147,2}{147,2 - 50} \right)$$

=1302,0 < 18000 Joule (from 150 Nm curve)  
The selected brake with 150 Nm is suitable.

#### Thermische Kapazität der Bremsen

Nach den oben genannten Berechnungen muss die Thermische Kapazität überprüft werden. Die Wärme, d.h. die gebrauchte Energie L, werden mit den folgenden Formeln berechnet. Die gerechnete Kapazitätswerte sollen unter dem Grenzkurve "Thermische Kapazität Grenzwerte" der gewählten Bremse liegen.

a) Konstantes Belastungsmoment  $M_L$ , das die Motordrehung fördert (Herunterlassen der Last)

$$L = \frac{I_{tot} \times (2\pi \times n_0 \div 60)^2}{2} \times \left( \frac{M_f}{M_f - M_L} \right)$$

b) Konstantes Belastungsmoment  $M_L$ , das sich entgegen der Motordrehung widersetzt (Aufheben der Last)

$$L = \frac{I_{tot} \times (2\pi \times n_0 \div 60)^2}{2} \times \frac{M_f}{M_f + M_L}$$

c) Konstantes Belastungsmoment  $M_L$ , das sich gegen der Motorbewegung widersetzt oder die Motorrotation fördert (Konstante Verminderung oder Erhöhung der Motorgeschwindigkeit, kein Herunterlassen oder Aufheben der Last)

$$L = \frac{I_{tot} \times (2\pi \times n_0 \div 60)^2}{2}$$

#### Einstellung des Luftspaltes:

Um eine immer konstant bleibende Bremsfähigkeit zu erhalten, muss das Luftspalt nach einer bestimmten Arbeitszeit neu eingestellt werden. Für die Bestimmung des Luftspaltes und die Einstellzeiten bitten wir Sie um Rückfrage.

#### Beispiel für eine Auswahl:

Die höchste zulässige Bremszeit: 0,5 s

Motordrehzahl: 1400 U/min

Gesamtträgheit der rotierenden Teile: 0,08 kgm<sup>2</sup>

Das auf das System wirkende Drehmoment: 50 Nm

Belastungsart: Drehmoment, das die Motorrotation fördert (Herunterlassen der Last)  
Betätigungen pro Stunde:30

$$M_{fc} = \frac{(2\pi \times 1400 \div 60)}{0,5 \times 0,995} + 50 = 73,6 \text{ Nm}$$

$$M_f = 73,6 \times 2 = 147,2 \text{ Nm}$$

Eine Bremse von 150 Nm kann man auswählen.

Die thermische Kapazität:

$$L = \frac{0,08 \times (2\pi \times 1400 \div 60)^2}{2} \times \left( \frac{147,2}{147,2 - 50} \right)$$

=1302,0 < 18000 Joule (von 150 Nm Kurve) Die ausgewählte 150 Nm Bremse ist ausreichend.

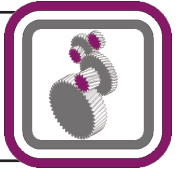

# Güç ve Devir Tabloları

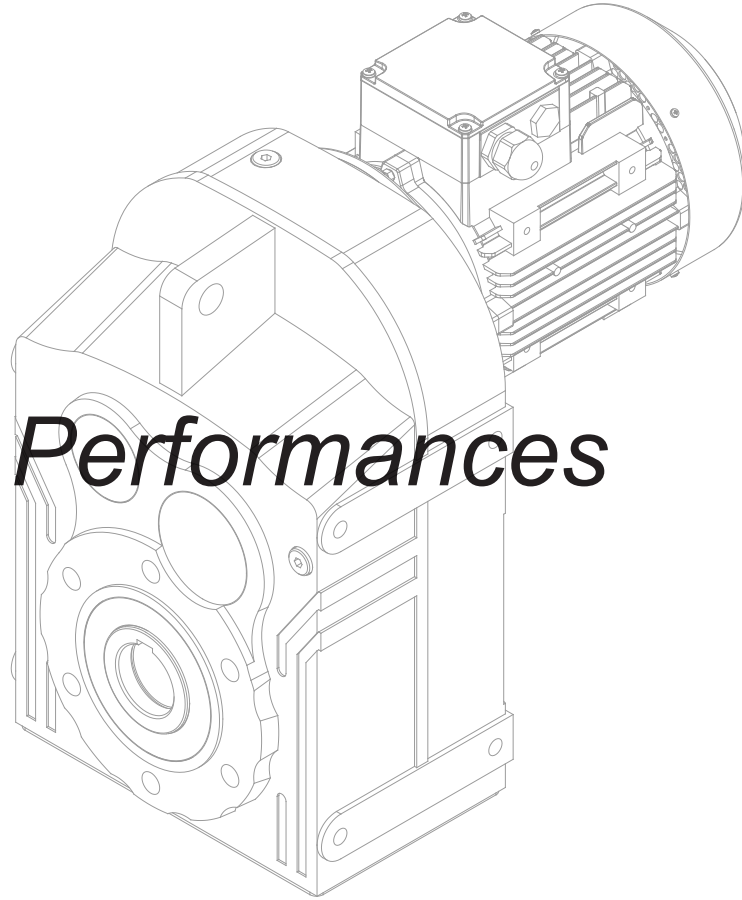

## Leistung und Drehzahlübersicht

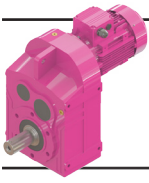

# D Serisi Motorlu Güç Devir Sayfaları

## D Series Geared Motors Performance Tables

### D Serien Getriebemotoren Leistung und Drehzahlübersicht



Güç	Çıkış Devri	Çıkış Momenti	Çevrim Oranı	Güv. Rad. Yük Çıkış	Servis Faktörü	Tipi	Anma Akımı	Ağırlık	Ölçü Sayfası	Motor Verim Snf.					
Power	Output Speeds	Output Torque	Ratio	Per.O. Loads (Output)	Service Factors	Type	Rated Current	Weight	Dim. Page	Motor Eff. Class					
Leistung P <sub>g</sub> [kW] P <sub>g</sub> [HP]	Abtriebswelle Drehzahlen n <sub>2</sub> [r.p.m]	Abtriebswelle Drehmomente M <sub>2</sub> [Nm]	Übersetzung i	Zul.Querkräfte (Abtrieb) F <sub>qam</sub> [N]	Betriebsfaktor f <sub>s</sub>	Typ	Nennstrom [A]	Gewicht ~ [kg]	Maße Seite	Motor Effizienz-klasse					
0,12 0,16	0,16	5541	8471,90	4977	0,8	DR676-G63/4a	0,41	283	126	IE1					
	0,19	4711	7216,80	24512	0,9										
	0,22	4123	6304,09	31273	1,0										
	0,23	3870	5912,93	33651	1,1										
	0,27	3293	5027,18	38311	1,3										
	0,31	2866	4366,47	41267	1,5										
	0,36	2512	3820,66	43388	1,7										
	0,42	2152	3215,89	45372	2,0										
	0,48	1919	2865,49	46557	2,2										
	0,56	1631	2440,98	47918	2,6										
0,64	1427	2132,27	48824	3,0	DR675-G63/4a	0,41	280	126	IE1						
	0,68	1340	1999,96	49198						3,2					
	0,24	3780	5762,85	-						0,8	DR576-G63/4a	0,41	165	120	IE1
	0,28	3216	4899,59	18917						0,9					
	0,32	2799	4255,64	24674						1,1					
0,40	2297	3432,03	29798	1,3	DR575-G63/4a	0,41	162	120	IE1						
	0,47	1943	2900,65	32737						1,5					
	0,57	1593	2379,02	35176						1,9					
	0,66	1394	2078,15	36430						2,2					
	0,70	1308	1949,20	36939						2,3					
	0,82	1113	1657,21	38040						2,7					
	0,95	968	1439,41	38802						3,1					
	0,48	1874	2851,73	11587						0,8	DR476-G63/4a	0,41	120	114	IE1
	0,57	1568	2381,67	16679						1,0					
0,70	1301	1937,71	19839	1,2	DR475-G63/4a	0,41	119	114	IE1						
	0,84	1087	1618,43	21861						1,4					
	0,89	1028	1529,03	22342						1,5					
	0,91	1002	1492,69	22590						1,5					
	1,2	767	1140,69	24345						2,0					
	1,3	717	1065,48	24683						2,2					
	1,5	607	900,55	25389						2,6					
	1,8	508	752,10	25976						3,1					
	2,1	439	648,55	26362						3,5					
	0,83	1074	1639,97	6508						0,8	DR376-G63/4a	0,41	79	108	IE1
0,90		972	1484,14	9186	0,8										
1,1		832	1272,49	11780	1,0										
1,1	793	1188,10	12374	1,0	DR375-G63/4a	0,41	78	108	IE1						
	1,3	706	1053,09	13565						1,2					
	1,5	624	930,99	14557						1,3					
	1,7	526	783,07	15569						1,6					
	2,1	447	665,75	16295						1,8					
	2,4	384	570,43	16832						2,1					
	2,6	347	516,22	17118						2,4					
	3,1	297	442,60	17490						2,8					
	3,6	255	378,91	17787						3,2					
	1,5	627	936,69	8724						1,0	DR285-G63/4a	0,41	35	104	IE1
1,6		558	830,25	10016	1,1										
1,9		494	733,99	11030	1,2										
2,2		416	617,37	12085	1,4										
2,6		354	524,87	12804	1,7										

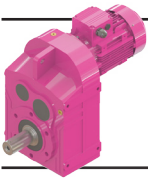

# D Serisi Motorlu Güç Devir Sayfaları

## D Series Geared Motors Performance Tables

### D Serien Getriebemotoren Leistung und Drehzahlübersicht

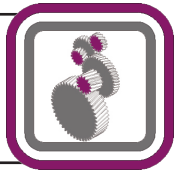

Güç	IE3 Çıkış Devri	IE3 Çıkış Momenti	Çevrim Oranı	IE3 Güv. Rad. Yük Çıkış Per.O. Loads (Output)	IE3 Servis Faktörü	Tipi	Anma Akımı	Ağırlık	Ölçü Sayfası	Motor* Verim Snf.
Power	Output Speeds	Output Torque	Ratio	Per.O. Loads (Output)	Service Factors	Type	Rated Current	Weight	Dim. Page	Motor Eff. Class
Leistung	Abtriebswelle Drehzahlen	Abtriebswelle Drehmomente	Übersetzung	Zul.Querkräfte (Abtrieb)	Betriebsfaktor	Typ	Nennstrom	Gewicht	Maße Seite	Motor Effizienzklasse
P <sub>g</sub> [kW]	n <sub>2</sub> [r.p.m]	M <sub>2</sub> [Nm]	i	F <sub>qam</sub> [N]	f <sub>s</sub>		[A]	[kg]		
0,12 0,16	3,0	303	449,72	13332	2,0	DR285-G63/4a	0,41	35	104	IE1
	3,4	275	406,99	13611	2,2					
	3,9	235	348,95	13972	2,6					
	4,6	202	298,73	14257	3,0					
1,7 1,9 2,3 2,7 3,3 3,8 4,1 5,4 6,4 6,6 7,5 9,1	552	823,76	10203	0,8	DR275-G63/4a	0,41	30	100	IE1	
	483	720,79	11435	0,9						
	400	596,04	12678	1,1						
	334	497,10	13501	1,3						
	280	416,71	14094	1,6						
	240	356,74	14491	1,9						
	223	331,04	14652	2,0						
	169	251,08	15123	2,7						
	145	214,95	15315	3,1						
	140	207,93	15352	3,2						
	123	181,94	15485	3,7						
102	150,45	15925	4,0							
9,9 11	107	137,94	15782	4,0	DR273-G63/4a	0,41	25	98	IE1	
	93	120,49	16179	4,0						
9,6 11 13 15 16 19 23	110	142,89	6977	1,8	DR173-G63/4a	0,41	20	96	IE1	
	93	120,64	7187	2,1						
	80	103,34	7338	2,5						
	71	91,25	7438	2,8						
	66	85,23	7486	3,0						
	56	72,04	7588	3,6						
	47	60,16	7794	4,0						
7,6 9,3 10 11 14 16 19 20 22 26 31 36 39	139	180,05	4731	1,1	DR073-G63/4a	0,41	15	94	IE1	
	113	146,60	4540	1,3						
	103	133,46	4448	1,5						
	93	120,11	4344	1,6						
	78	100,43	4163	1,9						
	66	85,12	3994	2,3						
	57	72,87	3836	2,7						
	52	67,62	3760	2,9						
	49	62,94	3688	3,1						
	41	52,62	3511	3,7						
	35	44,60	3350	4,0						
30	38,18	3204	4,0							
28	35,43	3134	4,0							
37 44 49 55 65 75 85 91 108 130 156 167 197 236	29	36,86	3171	4,0	DR072-G63/4a	0,41	14	94	IE1	
	24	30,71	3005	4,0						
	22	27,64	2912	4,0						
	20	25,01	2826	4,0						
	17	21,12	2684	4,0						
	14	18,09	2559	4,0						
	13	15,97	2463	4,0						
	12	14,92	2411	4,0						
	10	12,61	2287	4,0						
	8,3	10,53	2161	4,0						
	6,9	8,76	2034	4,0						
	6,4	8,18	1990	4,0						
	5,4	6,91	1886	4,0						
	4,5	5,77	1781	4,0						
0,18 0,25	0,09	14882	9820,98	65042	0,9	DR876-3E71M/6C	0,55	482	138	IE3
	0,11	13071	8612,25	76314	1,0	DR876-2E71M/6B	0,60	481		IE2

\*: IE2 ve IE3 motorlu redüktör fiyatları farklıdır. / Geared motor prices are different for IE2 and IE3 motors. / Preise von Getrieben mit IE2 und IE3 Motoren sind unterschiedlich.

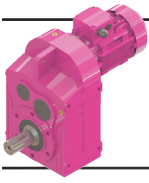

# D Serisi Motorlu Güç Devir Sayfaları

## D Series Geared Motors Performance Tables

### D Serien Getriebemotoren Leistung und Drehzahlübersicht



Güç	IE3 Çıkış Devri	IE3 Çıkış Momenti	Çevrim Oranı	IE3 Güv. Rad. Yük Çıkış	IE3 Servis Faktörü	Tipi	Anma Akımı	Ağırlık	Ölçü Sayfası	Motor Verim Sınıfı*
Power	Output Speeds	Output Torque	Ratio	Per. O. Loads (Output)	Service Factors	Type	Rated Current	Weight	Dim. Page	Motor Eff. Class
Leistung	Abtriebswelle Drehzahlen	Abtriebswelle Drehmomente	Übersetzung	Zul. Querkräfte (Abtrieb)	Betriebsfaktor	Typ	Nennstrom	Gewicht	Maße Seite	Motor Effizienzklasse
P <sub>g</sub> [kW] P <sub>g</sub> [HP]	n <sub>2</sub> [r.p.m]	M <sub>2</sub> [Nm]	i	F <sub>qam</sub> [N]	f <sub>s</sub>		[A]	[kg]		
0,18 0,25	0,12	11573	<b>7613,73</b>	84108	1,1	<b>DR876-3E71M/6C</b>	0,55	482	138	IE3
	0,14	10187	<b>6697,26</b>	90324	1,3	<b>DR876-2E71M/6B</b>	0,60	481		IE2
	0,16	9041	<b>5940,18</b>	94908	1,4					
	0,18	8078	<b>5304,23</b>	98429	1,6					
	0,20	7256	<b>4762,49</b>	101216	1,8					
	0,23	6116	<b>4005,78</b>	104787	2,1					
	0,27	5209	<b>3405,63</b>	107242	2,5					
	0,31	4673	<b>2990,66</b>	108721	2,8	<b>DR875-3E71M/6C</b>	0,55	507	138	IE3
	0,35	4196	<b>2683,53</b>	109985	3,1	<b>DR875-2E71M/6B</b>	0,60	506		IE2
	0,39	3678	<b>2356,74</b>	111300	3,5					
	0,14	9379	<b>6492,84</b>	43918	0,9	<b>DR776-3E71M/6C</b>	0,55	317	132	IE3
	0,16	8969	<b>5875,88</b>	47757	0,9	<b>DR776-2E71M/6B</b>	0,60	316		IE2
	0,18	7718	<b>5058,99</b>	57458	1,0					
	0,21	6625	<b>4334,63</b>	64282	1,2					
	0,25	5759	<b>3691,20</b>	68895	1,4	<b>DR775-3E71M/6C</b>	0,55	307	132	IE3
	0,28	5156	<b>3302,14</b>	71781	1,6	<b>DR775-2E71M/6B</b>	0,60	306		IE2
	0,33	4450	<b>2855,58</b>	74860	1,8					
	0,37	3939	<b>2523,53</b>	76914	2,0					
	0,41	3525	<b>2257,90</b>	78476	2,3					
	0,47	3101	<b>1982,78</b>	79874	2,6					
	0,56	2596	<b>1656,07</b>	81594	3,1					
	0,62	2360	<b>1507,38</b>	82358	3,4					
	0,70	2076	<b>1323,71</b>	83245	3,9					
	0,27	5311	<b>5027,18</b>	13734	0,8	<b>DR676-G63/4b</b>	0,60	283	126	IE1
	0,31	4622	<b>4366,47</b>	25702	0,9					
	0,35	4051	<b>3820,66</b>	31971	1,1					
	0,42	3470	<b>3215,89</b>	36975	1,2	<b>DR675-G63/4b</b>	0,60	225	126	IE1
	0,47	3094	<b>2865,49</b>	39716	1,4					
	0,55	2631	<b>2440,98</b>	42685	1,6					
	0,63	2302	<b>2132,27</b>	44625	1,9					
	0,67	2161	<b>1999,96</b>	45309	2,0					
	0,79	1839	<b>1700,37</b>	46946	2,3					
	0,91	1600	<b>1476,89</b>	48062	2,7					
	1,0	1402	<b>1292,28</b>	48933	3,1					
	1,3	1162	<b>1068,62</b>	49932	3,7					
	1,5	971	<b>891,23</b>	52171	4,0					
	1,8	816	<b>747,10</b>	54578	4,0					
	0,39	3705	<b>3432,03</b>	6392	0,8	<b>DR575-G63/4b</b>	0,60	164	120	IE1
	0,46	3134	<b>2900,65</b>	20225	1,0					
	0,56	2569	<b>2379,02</b>	27195	1,2					
	0,64	2248	<b>2078,15</b>	30229	1,3					
	0,69	2110	<b>1949,20</b>	31392	1,4					
	0,81	1795	<b>1657,21</b>	33794	1,7					
	0,93	1562	<b>1439,41</b>	35377	1,9					
	1,1	1369	<b>1259,48</b>	36555	2,2					
	1,3	1157	<b>720,91</b>	37796	2,6	<b>DR574-3E71M/6C</b>	0,55	161	118	IE3
	1,5	980	<b>609,29</b>	38690	3,1	<b>DR574-2E71M/6B</b>	0,60	160		IE2
	1,9	803	<b>499,72</b>	39581	3,7					
	0,69	2098	<b>1937,71</b>	4420	0,7	<b>DR475-G63/4b</b>	0,60	119	114	IE1
	0,83	1754	<b>1618,43</b>	13875	0,9					

\*: IE2 ve IE3 motorlu redüktör fiyatları farklıdır. / Geared motor prices are different for IE2 and IE3 motors. / Preise von Getrieben mit IE2 und IE3 Motoren sind unterschiedlich.

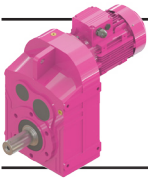

## D Serisi Motorlu Güç Devir Sayfaları

### D Series Geared Motors Performance Tables

#### D Serien Getriebemotoren Leistung und Drehzahlübersicht



Güç	IE3 Çıkış Devri	IE3 Çıkış Momenti	Çevrim Oranı	IE3 Güv. Rad. Yük Çıkış Per.O. Loads (Output)	IE3 Servis Faktörü	Tipi	Anma Akımı	Ağırlık	Ölçü Sayfası	Motor* Verim Snf.
Power	Output Speeds	Output Torque	Ratio	Per.O. Loads (Output)	Service Factors	Type	Rated Current	Weight	Dim. Page	Motor Eff. Class
Leistung P <sub>g</sub> [kW] P <sub>g</sub> [HP]	Abtriebswelle Drehzahlen n <sub>2</sub> [r.p.m]	Abtriebswelle Drehmomente M <sub>2</sub> [Nm]	Übersetzung i	Zul.Querkräfte (Abtrieb) F <sub>qam</sub> [N]	Betriebsfaktor f <sub>s</sub>	Typ	Nennstrom [A]	Gewicht ~ [kg]	Maße Seite	Motor Effizienz-klasse
0,18 0,25	0,88	1658	1529,03	15413	0,9	DR475-G63/4b	0,60	119	114	IE1
	0,90	1616	1492,69	16026	1,0					
	1,2	1238	1140,69	20473	1,3					
	1,3	1157	1065,48	21241	1,3					
	1,6	939	584,15	23051	1,7	DR474-3E71M/6C	0,55	116	114	IE3
	1,8	840	522,66	23833	1,8	DR474-2E71M/6B	0,60	115		IE2
	2,0	738	458,98	24543	2,1					
	2,3	652	584,15	25109	2,4	DR474-G63/4b	0,60	122	114	IE1
	2,6	583	522,66	25535	2,7					
	2,9	513	458,98	25950	3,0					
	1,3	1138	1053,09	3774	0,7	DR375-G63/4b	0,60	78	108	IE1
	1,4	1007	930,99	8386	0,8					
1,7	848	783,07	11523	1,0						
2,0	722	665,75	13362	1,1						
2,3	619	570,43	14600	1,3						
2,6	560	516,22	15225	1,5						
3,0	480	442,60	16023	1,7						
3,5	411	378,91	16603	2,0						
3,8	382	351,62	16843	2,1						
4,0	362	333,87	17000	2,3						
4,3	337	309,82	17199	2,4						
5,4	295	171,89	17481	2,8	DR373-3E71M/6C	0,55	72	106	IE3	
6,2	260	151,15	17734	3,2	DR373-2E71M/6B	0,60	71		IE2	
7,6	209	121,67	18075	3,9						
1,8	796	733,99	3280	0,8	DR285-G63/4b	0,60	38	104	IE1	
2,2	670	617,37	7760	0,9						
2,6	570	524,87	9801	1,1						
3,0	489	449,72	11096	1,2						
3,3	443	406,99	11733	1,4						
3,8	379	348,95	12517	1,6						
4,5	325	298,73	13117	1,8						
4,8	302	277,21	13335	2,0						
5,1	287	263,22	13476	2,1						
5,5	266	244,26	13689	2,3						
6,3	232	212,12	14001	2,6						
6,9	233	135,52	13986	2,6	DR283-3E71M/6C	0,55	35	102	IE3	
7,8	205	119,16	14207	2,9	DR283-2E71M/6B	0,60	34		IE2	
8,3	193	112,15	14307	3,1						
9,7	165	95,92	14534	3,6						
2,7	539	497,10	10461	0,8	DR275-G63/4b	0,60	30	100	IE1	
3,2	452	416,71	11931	1,0						
3,8	388	356,74	12837	1,2						
4,0	360	331,04	13188	1,2						
5,3	273	251,08	14169	1,6						
6,7	237	137,94	14523	1,9	DR273-3E71M/6C	0,55	27	98	IE3	
7,7	207	120,49	14777	2,2	DR273-2E71M/6B	0,60	26		IE2	
8,2	195	113,02	14891	2,3						
9,7	165	96,09	15140	2,7						
9,7	164	137,94	15165	2,7	DR273-G63/4b	0,60	22	98	IE1	
11	143	120,49	15329	3,1						

\*: IE2 ve IE3 motorlu redüktör fiyatları farklıdır. / Geared motor prices are different for IE2 and IE3 motors. / Preise von Getrieben mit IE2 und IE3 Motoren sind unterschiedlich.

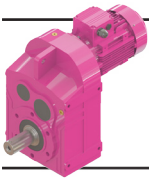

# D Serisi Motorlu Güç Devir Sayfaları

## D Series Geared Motors Performance Tables

### D Serien Getriebemotoren Leistung und Drehzahlübersicht



Güç	IE3 Çıkış Devri	IE3 Çıkış Momenti	Çevrim Oranı	IE3 Güv. Rad. Yük Çıkış	IE3 Servis Faktörü	Tipi	Anma Akımı	Ağırlık	Ölçü Sayfası	Motor Verim Snf.*
Power	Output Speeds	Output Torque	Ratio	Per.O. Loads (Output)	Service Factors	Type	Rated Current	Weight	Dim. Page	Motor Eff. Class
Leistung P <sub>g</sub> [kW] P <sub>g</sub> [HP]	Abtriebswelle Drehzahlen n <sub>2</sub> [r.p.m]	Abtriebswelle Drehmomente M <sub>2</sub> [Nm]	Übersetzung i	Zul.Querkräfte (Abtrieb) F <sub>qam</sub> [N]	Betriebsfaktor f <sub>s</sub>	Typ	Nennstrom [A]	Gewicht ~ [kg]	Maße Seite	Motor Effizienz-klasse
0,18 0,25	11	135	113,02	15380	3,3	DR273-G63/4b	0,60	22	98	IE1
	13	114	96,09	15547	3,9					
	16	100	83,46	15996	4,0					
	18	87	73,03	16343	4,0					
	6,5	245	142,89	4391	0,8	DR173-3E71M/6C	0,55	23	96	IE3
	7,7	207	120,64	5351	1,0	DR173-2E71M/6B	0,60	22		IE2
	9,0	178	103,34	5941	1,1					
	9,4	170	142,89	6085	1,2	DR173-G63/4b	0,60	20	96	IE1
	11	143	120,64	6512	1,4					
	13	123	103,34	6809	1,6					
	15	109	91,25	6997	1,8					
	16	102	85,23	7087	2,0					
19	86	72,04	7263	2,3						
22	72	60,16	7426	2,8						
26	62	51,88	7526	3,2						
28	57	47,81	7571	3,5						
30	53	44,66	7604	3,7						
35	45	37,75	7860	4,0						
43	38	31,52	8138	4,0						
7,4	213	180,05	4208	0,7	DR073-G63/4b	0,60	15	94	IE1	
9,1	174	146,60	4126	0,9						
10	159	133,46	4076	0,9						
11	143	120,11	4013	1,1						
13	119	100,43	3893	1,3						
16	101	85,12	3771	1,5						
18	87	72,87	3649	1,7						
20	81	67,62	3589	1,9						
21	75	62,94	3530	2,0						
25	63	52,62	3383	2,4						
30	53	44,60	3245	2,8						
35	46	38,18	3116	3,3						
38	42	35,43	3054	3,5						
36	45	36,86	3087	3,4	DR072-G63/4b	0,60	14	94	IE1	
44	37	30,71	2938	4,0						
48	34	27,64	2853	4,0						
54	30	25,01	2773	4,0						
63	26	21,12	2642	4,0						
74	22	18,09	2525	4,0						
84	19	15,97	2434	4,0						
90	18	14,92	2385	4,0						
106	15	12,61	2267	4,0						
127	13	10,53	2145	4,0						
153	11	8,76	2020	4,0						
164	9,9	8,18	1978	4,0						
194	8,4	6,91	1877	4,0						
232	7,0	5,77	1775	4,0						
268	6,0	10,53	1700	4,0	DR072-G63/2a	0,50	16	94	IE1	
322	5,0	8,76	1600	4,0						
345	4,6	8,18	1565	4,0						
408	3,9	6,91	1484	4,0						
488	3,2	5,77	1400	4,0						
0,25 0,34	0,15	13678	9820,98	72993	1,0	DR876-3E71M/4C	0,67	517	138	IE3
	0,17	12013	8612,25	81952	1,1	DR876-2E71M/4B	0,71	516		IE2
	0,19	10636	7613,73	88397	1,2					

\*: IE2 ve IE3 motorlu redüktör fiyatları farklıdır. / Geared motor prices are different for IE2 and IE3 motors. / Preise von Getrieben mit IE2 und IE3 Motoren sind unterschiedlich.

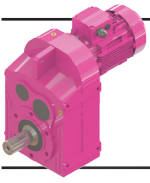

# D Serisi Motorlu Güç Devir Sayfaları

## D Series Geared Motors Performance Tables

### D Serien Getriebemotoren Leistung und Drehzahlübersicht



Güç	IE3 Çıkış Devri	IE3 Çıkış Momenti	Çevrim Oranı	IE3 Güv. Rad. Yük Çıkış Per.O. Loads (Output)	IE3 Servis Faktörü	Tipi	Anma Akımı	Ağırlık	Ölçü Sayfası	Motor* Verim Snf.	
Power	Output Speeds	Output Torque	Ratio	Per.O. Loads (Output)	Service Factors	Type	Rated Current	Weight	Dim. Page	Motor Eff. Class	
Leistung P <sub>g</sub> [kW] P <sub>g</sub> [HP]	Abtriebswelle Drehzahlen n <sub>2</sub> [r.p.m]	Abtriebswelle Drehmomente M <sub>2</sub> [Nm]	Übersetzung i	Zul.Querkräfte (Abtrieb) F <sub>qam</sub> [N]	Betriebsfaktor f <sub>s</sub>	Typ	Nennstrom [A]	Gewicht ~ [kg]	Maße Seite	Motor Effizienz-klasse	
0,25 0,34	0,21	9363	6697,26	93668	1,4	DR876-3E71M/4C	0,67	517	138	IE3	
	0,24	8310	5940,18	97608	1,6	DR876-2E71M/4B	0,71	516		IE2	
	0,27	7424	5304,23	100662	1,8						
	0,30	6669	4762,49	102950	1,9						
	0,36	5621	4005,78	106124	2,3						
	0,42	4788	3405,63	108461	2,7						
0,48 0,53 0,61	0,48	4295	2990,66	109770	3,0	DR875-3E71M/4C	0,67	507	138	IE3	
	0,53	3856	2683,53	110891	3,4	DR875-2E71M/4B	0,71	506		IE2	
	0,61	3381	2356,74	112120	3,8						
0,24 0,28 0,33 0,37	0,24	8243	5875,88	53790	1,0	DR776-3E71M/4C	0,67	317	132	IE3	
	0,28	7094	5058,99	61512	1,1	DR776-2E71M/4B	0,71	316		IE2	
	0,33	6089	4334,63	67209	1,3						
	0,37	5516	3922,75	69974	1,5						
0,39 0,43 0,50 0,57 0,64 0,72 0,87 0,95	0,39	5293	3691,20	71146	1,5	DR775-3E71M/4C	0,67	307	132	IE3	
	0,43	4738	3302,14	73639	1,7	DR775-2E71M/4B	0,71	306		IE2	
	0,50	4090	2855,58	76208	2,0						
	0,57	3620	2523,53	78031	2,2						
	0,64	3240	2257,90	79424	2,5						
	0,72	2850	1982,78	80780	2,8						
	0,87	2386	1656,07	82304	3,4						
	0,95	2169	1507,38	82984	3,7						
0,38	0,38	5365	3820,66	12259	0,8	DR676-3E71M/4C	0,67	286	126	IE3	
						DR676-2E71M/4B	0,71	285		IE2	
0,45 0,50 0,59 0,67 0,72 0,84 0,97 1,1	0,45	4596	3215,89	26001	0,9	DR675-3E71M/4C	0,67	228	126	IE3	
	0,50	4098	2865,49	31548	1,0	DR675-2E71M/4B	0,71	227		IE2	
	0,59	3484	2440,98	36869	1,2						
	0,67	3049	2132,27	40028	1,4						
	0,72	2862	1999,96	41201	1,5						
	0,84	2435	1700,37	43830	1,8						
	0,97	2119	1476,89	45468	2,0						
	1,1	1857	1292,28	46795	2,3						
	1,4 1,5 1,8	1,4	1539	675,51	48262	2,8	DR674-3E71M/6D	0,77	222	124	IE3
		1,5	1372	601,90	48998	3,1	DR674-2E71M/6C	0,78	221		IE2
1,8		1167	512,73	49860	3,7						
0,60 0,69 0,74 0,87 1,0 1,1	0,60	3402	2379,02	15470	0,9	DR575-3E71M/4C	0,67	166	120	IE3	
	0,69	2977	2078,15	22379	1,0	DR575-2E71M/4B	0,71	165		IE2	
	0,74	2794	1949,20	24736	1,1						
	0,87	2377	1657,21	29070	1,3						
	1,0	2068	1439,41	31731	1,5						
	1,1	1813	1259,48	33669	1,7						
1,3 1,5 1,9	1,3	1641	720,91	34856	1,8	DR574-3E71M/6D	0,77	162	118	IE3	
	1,5	1389	609,29	36458	2,2	DR574-2E71M/6C	0,78	161		IE2	
	1,9	1139	499,72	37896	2,6						
2,0 2,4	2,0	1064	720,91	38264	2,8	DR574-3E71M/4C	0,67	161	118	IE3	
	2,4	900	609,29	39116	3,3	DR574-2E71M/4B	0,71	160		IE2	
1,3 1,3	1,3	1639	1140,69	15667	0,9	DR475-3E71M/4C	0,67	123	114	IE3	
	1,3	1532	1065,48	17184	1,0	DR475-2E71M/4B	0,71	122		IE2	

\*: IE2 ve IE3 motorlu redüktör fiyatları farklıdır. / Geared motor prices are different for IE2 and IE3 motors. / Preise von Getrieben mit IE2 und IE3 Motoren sind unterschiedlich.

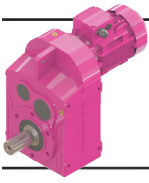

# D Serisi Motorlu Güç Devir Sayfaları

## D Series Geared Motors Performance Tables

### D Serien Getriebemotoren Leistung und Drehzahlübersicht



Güç	IE3 Çıkış Devri	IE3 Çıkış Momenti	Çevrim Oranı	IE3 Güv. Rad. Yük Çıkış Per. O. Loads (Output)	IE3 Servis Faktörü	Tipi	Anma Akımı	Ağırlık	Ölçü Sayfası	Motor Verim Snf.*
Power	Output Speeds	Output Torque	Ratio	Per. O. Loads (Output)	Service Factors	Type	Rated Current	Weight	Dim. Page	Motor Eff. Class
Leistung P <sub>g</sub> [kW] P <sub>g</sub> [HP]	Abtriebswelle Drehzahlen n <sub>2</sub> [r.p.m]	Abtriebswelle Drehmomente M <sub>2</sub> [Nm]	Übersetzung i	Zul. Querkräfte (Abtrieb) F <sub>qam</sub> [N]	Betriebsfaktor f <sub>s</sub>	Typ	Nennstrom [A]	Gewicht ~ [kg]	Maße Seite	Motor Effizienz-klasse
0,25 0,34	1,6	1332	<b>584,15</b>	19550	1,2	<b>DR474-3E71M/6D</b>	0,77	118	112	IE3
	1,8	1191	<b>522,66</b>	20924	1,3	<b>DR474-2E71M/6C</b>	0,78	117		IE2
	2,0	1047	<b>458,98</b>	22211	1,5					
	2,5	863	<b>584,15</b>	23664	1,8	<b>DR474-3E71M/4C</b>	0,67	118	112	IE3
	2,7	772	<b>522,66</b>	24276	2,0	<b>DR474-2E71M/4B</b>	0,71	117		IE2
	3,1	679	<b>458,98</b>	24906	2,3					
	3,8	582	<b>242,68</b>	25504	2,7	<b>DR473-3E71M/6D</b>	0,77	112	110	IE3
	4,3	515	<b>215,03</b>	25901	3,0	<b>DR473-2E71M/6C</b>	0,78	111		IE2
	5,3	420	<b>174,97</b>	26439	3,7					
	2,2	956	<b>665,75</b>	9491	0,9	<b>DR375-3E71M/4C</b>	0,67	82	108	IE3
	2,5	819	<b>570,43</b>	12007	1,0	<b>DR375-2E71M/4B</b>	0,71	81		IE2
	2,8	742	<b>516,22</b>	13095	1,1					
	3,2	635	<b>442,60</b>	14416	1,3					
	3,8	545	<b>378,91</b>	15380	1,5					
	4,1	506	<b>351,62</b>	15758	1,6					
	4,3	480	<b>333,87</b>	16001	1,7					
	4,6	446	<b>309,82</b>	16280	1,8					
	5,4	411	<b>171,89</b>	16604	2,0	<b>DR373-3E71M/6D</b>	0,77	72	106	IE3
	6,2	362	<b>151,15</b>	17004	2,3	<b>DR373-2E71M/6C</b>	0,78	71		IE2
	7,4	301	<b>121,67</b>	17463	2,7					
	8,3	266	<b>171,89</b>	17696	3,1	<b>DR373-3E71M/4C</b>	0,67	71	106	IE3
	9,5	234	<b>151,15</b>	17915	3,5	<b>DR373-2E71M/4B</b>	0,71	70		IE2
	2,7	755	<b>524,87</b>	5217	0,8	<b>DR285-3E71M/4C</b>	0,67	42	104	IE3
	3,2	648	<b>449,72</b>	8258	0,9	<b>DR285-3E71M/4B</b>	0,71	41		IE2
	3,5	586	<b>406,99</b>	9531	1,0					
	4,1	502	<b>348,95</b>	10907	1,2					
	4,8	431	<b>298,73</b>	11868	1,4					
	5,2	400	<b>277,21</b>	12270	1,5					
	5,5	379	<b>263,22</b>	12513	1,6					
	5,9	352	<b>244,26</b>	12816	1,7					
	6,8	307	<b>212,12</b>	13274	2,0					
		6,9	325	<b>135,52</b>	13110	1,8	<b>DR283-3E71M/6D</b>	0,77	37	102
7,8		286	<b>119,16</b>	13501	2,1	<b>DR283-2E71M/6C</b>	0,78	36		IE2
8,3		269	<b>112,15</b>	13660	2,2					
9,7		230	<b>95,92</b>	14013	2,6					
	11	210	<b>135,52</b>	14171	2,9	<b>DR283-3E71M/4C</b>	0,67	36	102	IE3
	12	185	<b>119,16</b>	14380	3,2	<b>DR283-2E71M/4B</b>	0,71	35		IE2
	13	174	<b>112,15</b>	14477	3,4					
	4,0	513	<b>356,74</b>	10925	0,9	<b>DR275-3E71M/4C</b>	0,67	33	100	IE3
	4,3	477	<b>331,04</b>	11541	0,9	<b>DR275-2E71M/4B</b>	0,71	32		IE2
	5,7	361	<b>251,08</b>	13172	1,2					
	6,7	330	<b>137,94</b>	13548	1,4	<b>DR273-3E71M/6D</b>	0,77	27	98	IE3
	7,7	289	<b>120,49</b>	14006	1,6	<b>DR273-2E71M/6C</b>	0,78	26		IE2
	8,2	271	<b>113,02</b>	14191	1,7					
	9,7	230	<b>96,09</b>	14587	2,0					

\*: IE2 ve IE3 motorlu redüktör fiyatları farklıdır. / Geared motor prices are different for IE2 and IE3 motors. / Preise von Getrieben mit IE2 und IE3 Motoren sind unterschiedlich.

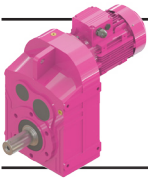

# D Serisi Motorlu Güç Devir Sayfaları

## D Series Geared Motors Performance Tables

### D Serien Getriebemotoren Leistung und Drehzahlübersicht



Güç	IE3 Çıkış Devri	IE3 Çıkış Momenti	Çevrim Oranı	IE3 Güv. Rad. Yük Çıkış Per.O. Loads (Output)	IE3 Servis Faktörü	Tipi	Anma Akımı	Ağırlık	Ölçü Sayfası	Motor* Verim Snf.
Power	Output Speeds	Output Torque	Ratio	Per.O. Loads (Output)	Service Factors	Type	Rated Current	Weight	Dim. Page	Motor Eff. Class
Leistung P <sub>g</sub> [kW] P <sub>g</sub> [HP]	Abtriebswelle Drehzahlen n <sub>2</sub> [r.p.m]	Abtriebswelle Drehmomente M <sub>2</sub> [Nm]	Übersetzung i	Zul.Querkräfte (Abtrieb) F <sub>qam</sub> [N]	Betriebsfaktor f <sub>s</sub>	Typ	Nennstrom [A]	Gewicht ~ [kg]	Maße Seite	Motor Effizienz- klasse
0,25 0,34	10	214	137,94	14725	2,1	DR273-3E71M/4C	0,67	26	98	IE3
	11	187	120,49	14963	2,4	DR273-2E71M/4B	0,71	25		IE2
	12	175	113,02	15061	2,6					
	14	149	96,09	15284	3,0					
	17	130	83,46	15434	3,5					
	19	114	73,03	15554	4,0					
	23	94	60,39	16165	4,0					
	10	221	142,89	5043	0,9	DR173-3E71M/4C	0,67	23	96	IE3
	12	187	120,64	5768	1,1	DR173-2E71M/4B	0,71	22		IE2
	14	160	103,34	6246	1,2					
	16	142	91,25	6541	1,4					
	17	132	85,23	6668	1,5					
	20	112	72,04	6948	1,8					
	24	94	60,16	7183	2,1					
	28	81	51,88	7327	2,5					
	30	74	47,81	7393	2,7					
	32	70	44,66	7440	2,9					
	38	59	37,75	7559	3,4					
	46	49	31,52	7675	4,0					
	11	206	133,46	3594	0,7	DR073-3E71M/4C	0,67	17	94	IE3
	12	186	120,11	3575	0,8	DR073-2E71M/4B	0,71	16		IE2
	14	156	100,43	3519	1,0					
	17	132	85,12	3446	1,1					
20	113	72,87	3364	1,3						
21	105	67,62	3321	1,4						
23	98	62,94	3277	1,5						
27	82	52,62	3163	1,8						
32	69	44,60	3051	2,2						
38	59	38,18	2943	2,5						
41	55	35,43	2890	2,7						
39	58	36,86	2918	2,6	DR072-3E71M/4C	0,67	16	94	IE3	
47	48	30,71	2790	3,1	DR072-2E71M/4B	0,71	15		IE2	
52	44	27,64	2715	3,4						
57	39	25,01	2645	3,8						
68	33	21,12	2527	4,0						
79	29	18,09	2421	4,0						
90	25	15,97	2337	4,0						
96	24	14,92	2292	4,0						
114	20	12,61	2183	4,0						
136	17	10,53	2070	4,0						
164	14	8,76	1950	4,0						
175	13	8,18	1910	4,0						
208	11	6,91	1816	4,0						
249	9,1	5,77	1718	4,0						
270	8,3	10,53	1681	4,0	DR072-G63/2b	0,67	17	94	IE1	
324	6,9	8,76	1582	4,0						
347	6,5	8,18	1549	4,0						
411	5,4	6,91	1469	4,0						
492	4,5	5,77	1388	4,0						
0,37 0,50	0,13	23148	7017,74	183787	0,8	DR976-3E80M/6B	1,03	804	144	IE3
	0,17	18163	5494,80	199937	1,0	DR976-2E80M/6A	1,08	803		IE2
	0,20	15205	4589,41	208242	1,2					
	0,25	12240	3686,99	215571	1,5					
	0,30	10248	3079,47	219985	1,8					
	0,32	9690	2909,37	221154	1,9					

\*: IE2 ve IE3 motorlu redüktör fiyatları farklıdır. / Geared motor prices are different for IE2 and IE3 motors. / Preise von Getrieben mit IE2 und IE3 Motoren sind unterschiedlich.



# D Serisi Motorlu Güç Devir Sayfaları

## D Series Geared Motors Performance Tables

### D Serien Getriebemotoren Leistung und Drehzahlübersicht



Güç	IE3 Çıkış Devri	IE3 Çıkış Momenti	Çevrim Oranı	IE3 Güv. Rad. Yük Çıkış Per. O. Loads (Output)	IE3 Servis Faktörü	Tipi	Anma Akımı	Ağırlık	Ölçü Sayfası	Motor Verim Snf.*
Power	Output Speeds	Output Torque	Ratio	Per. O. Loads (Output)	Service Factors	Type	Rated Current	Weight	Dim. Page	Motor Eff. Class
Leistung P <sub>g</sub> [kW] P <sub>g</sub> [HP]	Abtriebswelle Drehzahlen n <sub>2</sub> [r.p.m]	Abtriebswelle Drehmomente M <sub>2</sub> [Nm]	Übersetzung i	Zul. Querkräfte (Abtrieb) F <sub>qam</sub> [N]	Betriebsfaktor f <sub>s</sub>	Typ	Nennstrom [A]	Gewicht ~ [kg]	Maße Seite	Motor Effizienz-klasse
0,37 0,50	0,45	7066	2079,97	226259	2,5	DR975-3E80M/6B	1,03	792	144	IE3
	0,50	6348	1867,46	227547	2,8	DR975-2E80M/6A	1,08	791		IE2
	0,58	5408	1591,90	229169	3,3					
	0,66	4771	1403,36	230224	3,8					
	0,19	16228	7613,73	54505	0,8	DR876-3E71M/4D	0,97	517	138	IE3
	0,21	14285	6697,26	69094	0,9	DR876-2E71M/4C	1,00	516		IE2
	0,24	12678	5940,18	78510	1,0					
	0,27	11327	5304,23	85270	1,1					
	0,30	10175	4762,49	90375	1,3					
	0,36	8576	4005,78	96644	1,5					
	0,42	7305	3405,63	101056	1,8					
	0,48	0,53	6553	2990,66	103314	2,0	DR875-3E71M/4D	0,97	507	138
0,61		5884	2683,53	105351	2,2	DR875-2E71M/4C	1,00	506		IE2
0,70		5158	2356,74	107441	2,5					
0,79		4495	2051,67	109244	2,9					
0,88		3979	1813,10	110582	3,3					
0,88		3561	1622,25	111624	3,7					
0,33	0,37	9290	4334,63	44601	0,9	DR776-3E71M/4D	0,97	317	132	IE3
	0,37	8416	3922,75	52417	1,0	DR776-2E71M/4C	1,00	316		IE2
0,39	0,72	8076	3691,20	55068	1,0	DR775-3E71M/4D	0,97	307	132	IE3
	0,87	4349	1982,78	75155	1,8	DR775-2E71M/4C	1,00	306		IE2
	0,95	3641	1656,07	77955	2,2					
	1,1	3309	1507,38	79175	2,4					
	1,3	2911	1323,71	80572	2,7					
	1,3	2438	1105,59	82139	3,3					
0,59	0,67	5316	2440,98	13612	0,8	DR675-3E71M/4D	0,97	228	126	IE3
	0,72	4652	2132,27	25280	0,9	DR675-2E71M/4C	1,00	227		IE2
	0,84	4367	1999,96	28653	1,0					
	0,97	3715	1700,37	35001	1,2					
	1,1	3232	1476,89	38750	1,3					
	1,1	2833	1292,28	41394	1,5					
1,4	1,5	2347	675,51	44307	1,8	DR674-3E80M/6B	1,03	225	124	IE3
	1,8	2094	601,90	45615	2,1	DR674-2E80M/6A	1,08	224		IE2
	1,8	1781	512,73	47176	2,4					
2,1	2,4	1521	675,51	48366	2,8	DR674-3E71M/4D	0,97	222	124	IE3
	2,8	1357	601,90	49086	3,2	DR674-2E71M/4C	1,00	221		IE2
	2,8	1154	512,73	49931	3,7					
0,87	1,0	3627	1657,21	9632	0,8	DR575-3E71M/4D	0,97	166	120	IE3
	1,1	3156	1439,41	19861	1,0	DR575-2E71M/4C	1,00	165		IE2
	1,1	2766	1259,48	25078	1,1					
1,3	1,5	2504	720,91	27850	1,2	DR574-3E80M/6B	1,03	162	118	IE3
	1,9	2119	609,29	31317	1,4	DR574-2E80M/6A	1,08	161		IE2
	1,9	1738	499,72	34195	1,7					
2,0	2,4	1623	720,91	34978	1,8	DR574-3E71M/4D	0,97	161	118	IE3
	2,9	1374	609,29	36494	2,2	DR574-2E71M/4C	1,00	160		IE2
	2,9	1127	499,72	37923	2,7					

\*: IE2 ve IE3 motorlu redüktör fiyatları farklıdır. / Geared motor prices are different for IE2 and IE3 motors. / Preise von Getrieben mit IE2 und IE3 Motoren sind unterschiedlich.

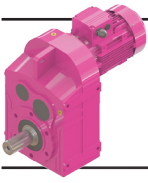

# D Serisi Motorlu Güç Devir Sayfaları

## D Series Geared Motors Performance Tables

### D Serien Getriebemotoren Leistung und Drehzahlübersicht



Güç	IE3 Çıkış Devri	IE3 Çıkış Momenti	Çevrim Oranı	IE3 Güv. Rad. Yük Çıkış Per.O. Loads (Output)	IE3 Servis Faktörü	Tipi	Anma Akımı	Ağırlık	Ölçü Sayfası	Motor Verim Snf.*
Power	Output Speeds	Output Torque	Ratio	Per.O. Loads (Output)	Service Factors	Type	Rated Current	Weight	Dim. Page	Motor Eff. Class
Leistung P <sub>g</sub> [kW] P <sub>g</sub> [HP]	Abtriebswelle Drehzahlen n <sub>2</sub> [r.p.m]	Abtriebswelle Drehmomente M <sub>2</sub> [Nm]	Übersetzung i	Zul.Querkräfte (Abtrieb) F <sub>qam</sub> [N]	Betriebsfaktor f <sub>s</sub>	Typ	Nennstrom [A]	Gewicht ~ [kg]	Maße Seite	Motor Effizienz-klasse
0,37 0,50	3,6	906	255,83	39089	3,3	DR573-3E80M/6B DR573-2E80M/6A	1,03 1,08	156 155	116	IE3 IE2
	1,8 2,0	1818 1598	522,66 458,98	12659 16315	0,9 1,0	DR474-3E80M/6B DR474-2E80M/6A	1,03 1,08	121 120	112	IE3 IE2
	2,5 2,7 3,1	1317 1178 1036	584,15 522,66 458,98	19670 21049 22310	1,2 1,3 1,5	DR474-3E71M/4D DR474-2E71M/4C	0,97 1,00	118 117	112	IE3 IE2
	3,8 4,3 5,3	860 762 621	242,68 215,03 174,97	23651 24354 25280	1,8 2,0 2,5	DR473-3E80M/6B DR473-2E80M/6A	1,03 1,08	113 112	110	IE3 IE2
	5,9 6,7	559 495	242,68 215,03	25654 26027	2,8 3,1	DR473-3E71M/4D DR473-2E71M/4C	0,97 1,00	110 109	110	IE3 IE2
	3,2 3,8 4,1 4,3 4,6	969 831 772 732 680	442,60 378,91 351,62 333,87 309,82	9249 11814 12674 13220 13882	0,8 1,0 1,1 1,1 1,2	DR375-3E71M/4D DR375-2E71M/4C	0,97 1,00	82 81	108	IE3 IE2
	5,4 6,2 7,6	608 535 431	171,89 151,15 121,67	14717 15455 16416	1,3 1,5 1,9	DR373-3E80M/6B DR373-2E80M/6A	1,03 1,08	75 74	106	IE3 IE2
	8,3 9,5 11 13	395 348 280 246	171,89 151,15 121,67 106,69	16714 17094 17598 17836	2,1 2,4 2,9 3,3	DR373-3E71M/4D DR373-2E71M/4C	0,97 1,00	72 71	106	IE3 IE2
	4,1 4,8 5,2 5,5 5,9	766 657 610 579 538	348,95 298,73 277,21 263,22 244,26	4790 8036 9060 9669 10350	0,8 0,9 1,0 1,0 1,1	DR285-3E71M/4D DR285-2E71M/4C	0,97 1,00	42 41	104	IE3 IE2
	6,9 7,8 8,3 9,7	480 423 398 341	135,52 119,16 112,15 95,92	11219 11988 12292 12924	1,2 1,4 1,5 1,8	DR283-3E80M/6B DR283-2E80M/6A	1,03 1,08	37 36	102	IE3 IE2
	11 12 13 15 17 19	312 275 259 221 194 172	135,52 119,16 112,15 95,92 84,12 74,36	13217 13588 13740 14076 14305 14496	1,9 2,2 2,3 2,7 3,1 3,5	DR283-3E71M/4D DR283-2E71M/4C	0,97 1,00	35 34	102	IE3 IE2
	6,7 7,7 8,2 9,7	488 427 400 340	137,94 120,49 113,02 96,09	11361 12304 12669 13404	0,9 1,1 1,1 1,3	DR273-3E80M/6B DR273-2E80M/6A	1,03 1,08	30 29	98	IE3 IE2

\*: IE2 ve IE3 motorlu redüktör fiyatları farklıdır. / Geared motor prices are different for IE2 and IE3 motors. / Preise von Getrieben mit IE2 und IE3 Motoren sind unterschiedlich.

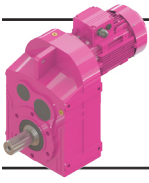

# D Serisi Motorlu Güç Devir Sayfaları

## D Series Geared Motors Performance Tables

### D Serien Getriebemotoren Leistung und Drehzahlübersicht



Güç	IE3 Çıkış Devri	IE3 Çıkış Momenti	Çevrim Oranı	IE3 Güv. Rad. Yük Çıkış Per.O. Loads (Output)	IE3 Servis Faktörü	Tipi	Anma Akımı	Ağırlık	Ölçü Sayfası	Motor Verim Snf.*	
Power	Output Speeds	Output Torque	Ratio	Per.O. Loads (Output)	Service Factors	Type	Rated Current	Weight	Dim. Page	Motor Eff. Class	
Leistung	Abtriebswelle Drehzahlen	Abtriebswelle Drehmomente	Übersetzung	Zul.Querkräfte (Abtrieb)	Betriebsfaktor	Typ	Nennstrom	Gewicht	Maße Seite	Motor Effizienz-kategorie	
P <sub>g</sub> [kW] P <sub>g</sub> [HP]	n <sub>2</sub> [r.p.m]	M <sub>2</sub> [Nm]	i	F <sub>qam</sub> [N]	f <sub>s</sub>		[A]	[kg]			
0,37 0,50	10	317	137,94	13694	1,4	DR273-3E71M/4D	0,97	27	98	IE3	
	11	277	120,49	14103	1,6	DR273-2E71M/4C	1,00	26		IE2	
	12	260	113,02	14278	1,7						
	14	221	96,09	14655	2,0						
	17	192	83,46	14915	2,3						
	19	169	73,03	15118	2,7						
	23	140	60,39	15359	3,2						
	28	117	50,36	15532	3,9						
	34	98	42,22	16051	4,0						
	39	84	36,38	16431	4,0						
	14	238	103,34	4596	0,8	DR173-3E71M/4D	0,97	23	96	IE3	
	16	210	91,25	5288	1,0	DR173-2E71M/4C	1,00	22		IE2	
	17	196	85,23	5576	1,0						
	20	166	72,04	6147	1,2						
	24	139	60,16	6581	1,4						
	28	120	51,88	6850	1,7						
	30	110	47,81	6972	1,8						
	32	103	44,66	7061	1,9						
	38	87	37,75	7256	2,3						
	46	73	31,52	7408	2,7						
	48	70	29,67	7441	2,9	DR172-3E71M/4D	0,97	21	96	IE3	
	57	59	25,24	7523	3,4	DR172-2E71M/4C	1,00	20		IE2	
	66	51	21,79	7217	3,9						
	75	45	19,04	6941	4,0						
	17	196	85,12	2958	0,8	DR073-3E71M/4D	0,97	16	94	IE3	
	20	168	72,87	2953	0,9	DR073-2E71M/4C	1,00	15		IE2	
	21	156	67,62	2941	1,0						
	23	145	62,94	2926	1,0						
	27	121	52,62	2873	1,2						
	32	103	44,60	2809	1,5						
	38	88	38,18	2738	1,7						
	41	82	35,43	2701	1,8						
		39	86	36,86	2720	1,7	DR072-3E71M/4D	0,97	15	94	IE3
		47	72	30,71	2626	2,1	DR072-2E71M/4C	1,00	14		IE2
52		65	27,64	2569	2,3						
57		59	25,01	2513	2,6						
68		50	21,12	2417	3,0						
79		43	18,09	2327	3,5						
90		38	15,97	2255	4,0						
96		35	14,92	2215	4,0						
114		30	12,61	2118	4,0						
136		25	10,53	2016	4,0						
164		21	8,76	1901	4,0						
175		19	8,18	1865	4,0						
208		16	6,91	1777	4,0						
249		14	5,77	1686	4,0						
		269	12	10,53	1656	4,0	DR072-3E71M/2B	0,86	17	94	IE3
	323	10	8,76	1559	4,0	DR072-2E71M/2A	0,90	16		IE2	
	346	10	8,18	1528	4,0						
	409	8,2	6,91	1452	4,0						
0,55 0,75	0,21	22069	7017,74	187652	0,8	DR976-3E80M/4C	1,34	804	144	IE3	
	0,26	17317	5494,80	202689	1,0	DR976-2E80M/4B	1,45	803		IE2	
	0,32	14496	4589,41	210277	1,2						
	0,39	11669	3686,99	216743	1,5						

\*: IE2 ve IE3 motorlu redüktör fiyatları farklıdır. / Geared motor prices are different for IE2 and IE3 motors. / Preise von Getrieben mit IE2 und IE3 Motoren sind unterschiedlich.



# D Serisi Motorlu Güç Devir Sayfaları

## D Series Geared Motors Performance Tables

### D Serien Getriebemotoren Leistung und Drehzahlübersicht

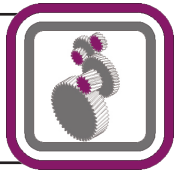

Güç	IE3 Çıkış Devri	IE3 Çıkış Momenti	Çevrim Oranı	IE3 Güv. Rad. Yük Çıkış Per.O. Loads (Output)	IE3 Servis Faktörü	Tipi	Anma Akımı	Ağırlık	Ölçü Sayfası	Motor Verim Snf.*
Power	Output Speeds	Output Torque	Ratio	Per.O. Loads (Output)	Service Factors	Type	Rated Current	Weight	Dim. Page	Motor Eff. Class
Leistung P <sub>g</sub> [kW] P <sub>g</sub> [HP]	Abtriebswelle Drehzahlen n <sub>2</sub> [r.p.m]	Abtriebswelle Drehmomente M <sub>2</sub> [Nm]	Übersetzung i	Zul.Querkräfte (Abtrieb) F <sub>qam</sub> [N]	Betriebsfaktor f <sub>s</sub>	Typ	Nennstrom [A]	Gewicht ~ [kg]	Maße Seite	Motor Effizienz-klasse
0,55 0,75	0,47	9771	3079,47	220885	1,8	DR976-3E80M/4C	1,34	804	144	IE3
	0,50	9238	2909,37	221983	1,9	DR976-2E80M/4B	1,45	803		IE2
	0,70	6736	2079,97	226794	2,7	DR975-3E80M/4C	1,34	792	144	IE3
	0,78	6052	1867,46	228013	3,0	DR975-2E80M/4B	1,45	791		IE2
	0,91	5156	1591,90	229547	3,5					
	0,30	14969	4762,49	64430	0,9	DR876-3E80M/4C	1,34	520	138	IE3
	0,36	12616	4005,78	78918	1,0	DR876-2E80M/4B	1,45	519		IE2
	0,43	10746	3405,63	87913	1,2					
	0,48	9640	2990,66	92569	1,3	DR875-3E80M/4C	1,34	510	138	IE3
	0,54	8656	2683,53	96350	1,5	DR875-2E80M/4B	1,45	509		IE2
	0,62	7588	2356,74	100112	1,7					
	0,71	6613	2051,67	103271	2,0					
	0,80	5854	1813,10	105562	2,2					
	0,89	5239	1622,25	107165	2,5					
	1,0	4609	1424,58	108901	2,8					
	1,2	3859	1189,85	110853	3,4					
	1,4	3397	1046,63	111995	3,8					
	0,51	9181	2855,58	45826	0,9	DR775-3E80M/4C	1,34	310	132	IE3
	0,57	8126	2523,53	54478	1,0	DR775-2E80M/4B	1,45	309		IE2
	0,64	7272	2257,90	60514	1,1					
	0,73	6397	1982,78	65553	1,3					
	0,88	5356	1656,07	70852	1,5					
	0,96	4868	1507,38	73071	1,6					
	1,1	4283	1323,71	75549	1,9					
1,3	3586	1105,59	78253	2,2						
	1,5	3262	632,92	79426	2,5	DR774-3E80M/6C	1,47	303	130	IE3
	1,7	2921	566,21	80608	2,7	DR774-2E80M/6B	1,50	302		IE2
	1,9	2523	489,64	81922	3,2					
	0,98	4755	1476,89	23887	0,9	DR675-3E80M/4C	1,34	331	126	IE3
	1,1	4168	1292,28	30820	1,0	DR675-2E80M/4B	1,45	330		IE2
	1,4	3471	675,51	36972	1,2	DR674-3E80M/6C	1,47	225	124	IE3
	1,6	3096	601,90	39707	1,4	DR674-2E80M/6B	1,50	224		IE2
	1,8	2633	512,73	42671	1,6					
	2,1	2238	675,51	44914	1,9	DR674-3E80M/4C	1,34	225	124	IE3
	2,4	1996	601,90	46171	2,2	DR674-2E80M/4B	1,45	224		IE2
	2,8	1698	512,73	47611	2,5					
	3,4	1409	424,33	48840	3,1					
	4,0	1206	362,91	49703	3,6					
	1,5	3134	609,29	20249	1,0	DR574-3E80M/6C	1,47	162	118	IE3
	1,9	2570	499,72	27186	1,2	DR574-2E80M/6B	1,50	161		IE2
	2,0	2388	720,91	29025	1,3	DR574-3E80M/4C	1,34	163	118	IE3
	2,4	2021	609,29	32110	1,5	DR574-2E80M/4B	1,45	162		IE2
	2,9	1657	499,72	34749	1,8					

\*: IE2 ve IE3 motorlu redüktör fiyatları farklıdır. / Geared motor prices are different for IE2 and IE3 motors. / Preise von Getrieben mit IE2 und IE3 Motoren sind unterschiedlich.

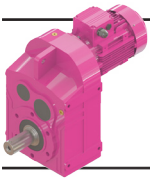

# D Serisi Motorlu Güç Devir Sayfaları

## D Series Geared Motors Performance Tables

### D Serien Getriebemotoren Leistung und Drehzahlübersicht

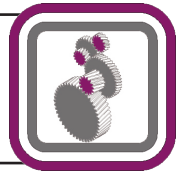

Güç	IE3 Çıkış Devri	IE3 Çıkış Momenti	Çevrim Oranı	IE3 Güv. Rad. Yük Çıkış	IE3 Servis Faktörü	Tipi	Anma Akımı	Ağırlık	Ölçü Sayfası	Motor Verim Sınıfı*
Power	Output Speeds	Output Torque	Ratio	Per. O. Loads (Output)	Service Factors	Type	Rated Current	Weight	Dim. Page	Motor Eff. Class
Leistung P <sub>g</sub> [kW] P <sub>g</sub> [HP]	Abtriebswelle Drehzahlen n <sub>2</sub> [r.p.m]	Abtriebswelle Drehmomente M <sub>2</sub> [Nm]	Übersetzung i	Zul. Querkräfte (Abtrieb) F <sub>qam</sub> [N]	Betriebsfaktor f <sub>s</sub>	Typ	Nennstrom [A]	Gewicht ~ [kg]	Maße Seite	Motor Effizienz-klasse
0,55 0,75	3,7	1342	255,83	36738	2,2	DR573-3E80M/6C	1,47	156	116	IE3
	4,5	1103	209,81	38094	2,7	DR573-2E80M/6B	1,50	155		IE2
	5,7	867	255,83	39263	3,5	DR573-3E80M/4C	1,34	155	116	IE3
						DR573-2E80M/4B	1,45	154		IE2
	2,5	1937	584,15	10111	0,8	DR474-3E80M/4C	1,34	121	112	IE3
	2,8	1733	522,66	14215	0,9	DR474-2E80M/4B	1,45	120		IE2
	3,2	1523	458,98	17235	1,0					
	3,9	1275	242,68	20103	1,2	DR473-3E80M/6C	1,47	113	110	IE3
	4,3	1129	215,03	21494	1,4	DR473-2E80M/6B	1,50	112		IE2
	5,3	921	174,97	23231	1,7					
	6,0	823	242,68	23953	1,9	DR473-3E80M/4C	1,34	112	110	IE3
	6,7	729	215,03	24603	2,1	DR473-2E80M/4B	1,45	111		IE2
	8,3	595	174,97	25426	2,6					
	10	471	138,35	26158	3,3					
	4,7	1001	309,82	8517	0,8	DR375-3E80M/4C	1,34	85	108	IE3
						DR375-2E80M/4B	1,45	84		IE2
	5,4	901	171,89	10607	0,9	DR373-3E80M/6C	1,47	77	106	IE3
	6,2	793	151,15	12370	1,0	DR373-2E80M/6B	1,50	76		IE2
	7,7	639	121,67	14372	1,3					
	8,4	582	171,89	14998	1,4	DR373-3E80M/4C	1,34	76	106	IE3
	9,6	512	151,15	15698	1,6	DR373-2E80M/4B	1,45	75		IE2
	12	413	121,67	16592	2,0					
	14	362	106,69	17001	2,3					
	15	321	94,32	17295	2,6					
	18	270	79,34	17664	3,0					
	21	230	67,45	17940	3,6					
	6,9	712	135,52	6656	0,8	DR283-3E80M/6C	1,47	74	102	IE3
	7,8	627	119,16	8728	1,0	DR283-2E80M/6B	1,50	73		IE2
	8,3	590	112,15	9443	1,0					
	9,7	505	95,92	10864	1,2					
	11	460	135,52	11506	1,3	DR283-3E80M/4C	1,34	38	102	IE3
	12	405	119,16	12212	1,5	DR283-2E80M/4B	1,45	37		IE2
	13	381	112,15	12492	1,6					
	15	326	95,92	13098	1,8					
	17	286	84,12	13498	2,1					
	19	253	74,36	13807	2,4					
	23	213	62,55	14139	2,8					
	27	182	53,18	14404	3,3					
	10	467	137,94	11699	1,0	DR273-3E80M/4C	1,34	32	98	IE3
	12	408	120,49	12560	1,1	DR273-2E80M/4B	1,45	31		IE2
	13	383	113,02	12896	1,2					
	15	326	96,09	13595	1,4					
	17	283	83,46	14060	1,6					
	19	248	73,03	14415	1,8					
	24	206	60,39	14793	2,2					
28	172	50,36	15088	2,6						

\*: IE2 ve IE3 motorlu redüktör fiyatları farklıdır. / Geared motor prices are different for IE2 and IE3 motors. / Preise von Getrieben mit IE2 und IE3 Motoren sind unterschiedlich.

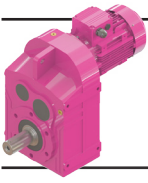

# D Serisi Motorlu Güç Devir Sayfaları

## D Series Geared Motors Performance Tables

### D Serien Getriebemotoren Leistung und Drehzahlübersicht

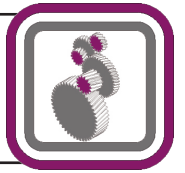

Güç Power Leistung P <sub>g</sub> [kW] P <sub>g</sub> [HP]	IE3	IE3	Çevrim Oranı Ratio Übersetzung i	IE3	IE3	Tipi Type Typ	Anma Akımı Rated Current Nennstrom [A]	Ağırlık Weight Gewicht ~ [kg]	Ölçü Sayfası Dim. Page Maße Seite	Motor*
	Çıkış Devri Output Speeds Abtriebswelle Drehzahlen n <sub>2</sub> [r.p.m]	Çıkış Momenti Output Torque Abtriebswelle Drehmomente M <sub>2</sub> [Nm]		Güv. Rad. Yük Çıkış Per.O. Loads (Output) Zul.Querkräfte (Abtrieb) F <sub>qam</sub> [N]	Servis Faktörü Service Factors Betriebsfaktor f <sub>s</sub>					Motor Verim Sınıfı Motor Eff. Class Motor Effizienzklasse
0,55 0,75	34	144	<b>42,22</b>	15312	3,1	<b>DR273-3E80M/4C</b>	1,34	32	98	IE3
	39	124	<b>36,38</b>	15466	3,6	<b>DR273-2E80M/4B</b>	1,45	31		IE2
	47	104	<b>30,34</b>	15864	4,0					
	56	89	<b>25,78</b>	16303	4,0	<b>DR272-3E80M/4C</b> <b>DR272-2E80M/4B</b>	1,34 1,45	29 28	98	IE3 IE2
	20	244	<b>72,04</b>	4406	0,8	<b>DR173-3E80M/4C</b>	1,34	26	96	IE3
	24	204	<b>60,16</b>	5414	1,0	<b>DR173-2E80M/4B</b>	1,45	25		IE2
	28	176	<b>51,88</b>	5961	1,1					
	30	163	<b>47,81</b>	6193	1,2					
	32	152	<b>44,66</b>	6378	1,3					
	38	129	<b>37,75</b>	6721	1,6					
	46	107	<b>31,52</b>	7010	1,9					
	53	93	<b>27,18</b>	7182	2,2					
	67	75	<b>21,79</b>	6944	2,7	<b>DR172-3E80M/4C</b>	1,34	23	96	IE3
	76	66	<b>19,04</b>	6702	3,0	<b>DR172-2E80M/4B</b>	1,45	22		IE2
	81	62	<b>17,86</b>	6588	3,2					
	96	53	<b>15,18</b>	6302	3,8					
	110	46	<b>13,19</b>	6058	4,0					
	28	179	<b>52,62</b>	2417	0,8	<b>DR073-3E80M/4C</b>	1,34	17	94	IE3
	33	152	<b>44,60</b>	2427	1,0	<b>DR073-2E80M/4B</b>	1,45	16		IE2
	38	130	<b>38,18</b>	2414	1,2					
	41	121	<b>35,43</b>	2402	1,2					
	39	127	<b>36,86</b>	2409	1,2	<b>DR072-3E80M/4C</b>	1,34	16	94	IE3
	47	106	<b>30,71</b>	2369	1,4	<b>DR072-2E80M/4B</b>	1,45	15		IE2
	52	96	<b>27,64</b>	2339	1,6					
	58	86	<b>25,01</b>	2306	1,7					
	69	73	<b>21,12</b>	2242	2,1					
	80	63	<b>18,09</b>	2178	2,4					
	91	55	<b>15,97</b>	2123	2,7					
	97	52	<b>14,92</b>	2092	2,9					
	115	44	<b>12,61</b>	2014	3,4					
	138	37	<b>10,53</b>	1929	4,0					
	166	30	<b>8,76</b>	1821	4,0					
	177	28	<b>8,18</b>	1790	4,0					
	210	24	<b>6,91</b>	1714	4,0					
	251	20	<b>5,77</b>	1633	4,0					
	269	19	<b>10,53</b>	1615	4,0	<b>DR072-3E71M/2C</b>	1,19	17	94	IE3
	323	16	<b>8,76</b>	1522	4,0	<b>DR072-2E71M/2B</b>	1,25	16		IE2
	346	15	<b>8,18</b>	1493	4,0					
	409	12	<b>6,91</b>	1422	4,0					
	490	10	<b>5,77</b>	1349	4,0					
0,75 1,0	0,32	19768	<b>4589,41</b>	195316	0,9	<b>DR976-3E80M/4D</b>	1,77	805	144	IE3
	0,39	15913	<b>3686,99</b>	206283	1,1					
	0,47	13324	<b>3079,47</b>	212951	1,4					
	0,50	12597	<b>2909,37</b>	214691	1,4					
	0,70	9186	<b>2079,97</b>	222154	2,0	<b>DR975-3E80M/4D</b>	1,77	793	144	IE3
	0,78	8253	<b>1867,46</b>	224002	2,2					
	0,91	7031	<b>1591,90</b>	226303	2,6					
	1,0	6203	<b>1403,36</b>	227786	2,9					
	1,2	5507	<b>1244,98</b>	228987	3,3					
	1,3	4914	<b>1110,06</b>	229979	3,7					

\*: IE2 ve IE3 motorlu redüktör fiyatları farklıdır. / Geared motor prices are different for IE2 and IE3 motors. / Preise von Getrieben mit IE2 und IE3 Motoren sind unterschiedlich.

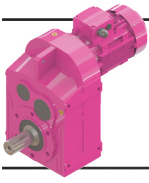

## D Serisi Motorlu Güç Devir Sayfaları

### D Series Geared Motors Performance Tables

#### D Serien Getriebemotoren Leistung und Drehzahlübersicht



Güç	IE3 Çıkış Devri	IE3 Çıkış Momenti	Çevrim Oranı	IE3 Güv. Rad. Yük Çıkış	IE3 Servis Faktörü	Tipi	Anma Akımı	Ağırlık	Ölçü Sayfası	Motor Verim Snf.
Power	Output Speeds	Output Torque	Ratio	Per.O. Loads (Output)	Service Factors	Type	Rated Current	Weight	Dim. Page	Motor Eff. Class
Leistung P <sub>g</sub> [kW] P <sub>g</sub> [HP]	Abtriebswelle Drehzahlen n <sub>2</sub> [r.p.m]	Abtriebswelle Drehmomente M <sub>2</sub> [Nm]	Übersetzung i	Zul.Querkräfte (Abtrieb) F <sub>qam</sub> [N]	Betriebsfaktor f <sub>s</sub>	Typ	Nennstrom [A]	Gewicht ~ [kg]	Maße Seite	Motor Effizienz-klasse
0,75 1,0	0,43	14654	<b>3405,63</b>	66595	0,9	<b>DR876-3E80M/4D</b>	1,77	521	138	IE3
	0,48	13146	<b>2990,66</b>	75941	1,0	<b>DR875-3E80M/4D</b>	1,77	511	138	IE3
	0,54	11804	<b>2683,53</b>	82989	1,1					
	0,62	10348	<b>2356,74</b>	89644	1,3					
	0,71	9018	<b>2051,67</b>	94998	1,4					
	0,80	7982	<b>1813,10</b>	98730	1,6					
	0,89	7144	<b>1622,25</b>	101421	1,8					
	1,0	6284	<b>1424,58</b>	104147	2,1					
	1,2	5262	<b>1189,85</b>	107152	2,5					
	1,4	4633	<b>1046,63</b>	108879	2,8					
1,6	4113	<b>928,31</b>	110242	3,2						
1,7	3675	<b>828,93</b>	111344	3,5						
	0,64	9917	<b>2257,90</b>	38132	0,8	<b>DR775-3E80M/4D</b>	1,77	311	132	IE3
	0,73	8724	<b>1982,78</b>	49865	0,9					
	0,88	7303	<b>1656,07</b>	60205	1,1					
	0,96	6639	<b>1507,38</b>	64203	1,2					
	1,1	5840	<b>1323,71</b>	68487	1,4					
1,3	4890	<b>1105,59</b>	72910	1,6						
	1,5	4401	<b>632,92</b>	74126	1,7	<b>DR774-3E90S/6B</b>	1,96	305	130	IE3
	1,7	3941	<b>566,21</b>	76103	1,9					
	1,9	3404	<b>489,64</b>	78248	2,2					
	2,3	2868	<b>632,92</b>	80719	2,8	<b>DR774-3E80M/4D</b>	1,77	301	130	IE3
	2,6	2569	<b>566,21</b>	81717	3,1					
	3,0	2218	<b>489,64</b>	82832	3,6					
	1,4	4683	<b>675,51</b>	24804	0,9	<b>DR674-3E90S/6B</b>	1,96	227	124	IE3
	1,6	4177	<b>601,90</b>	30824	1,0					
	1,8	3553	<b>512,73</b>	36327	1,2					
	2,1	3052	<b>675,51</b>	40007	1,4	<b>DR674-3E80M/4D</b>	1,77	226	124	IE3
	2,4	2722	<b>601,90</b>	42135	1,6					
	2,8	2316	<b>512,73</b>	44462	1,9					
	3,4	1921	<b>424,33</b>	46477	2,2					
	4,0	1645	<b>362,91</b>	47806	2,6					
	4,6	1445	<b>318,25</b>	48705	3,0					
5,2	1279	<b>281,35</b>	49415	3,4						
	1,9	3468	<b>499,72</b>	13905	0,9	<b>DR574-3E90S/6B</b>	1,96	167	118	IE3
	2,0	3256	<b>720,91</b>	18226	0,9	<b>DR574-3E80M/4D</b>	1,77	165	118	IE3
	2,4	2755	<b>609,29</b>	25206	1,1					
2,9	2260	<b>499,72</b>	30126	1,3						
	3,7	1810	<b>255,83</b>	33689	1,7	<b>DR573-3E90S/6B</b>	1,96	161	116	IE3
	4,5	1487	<b>209,81</b>	35805	2,0					
	4,9	1365	<b>192,62</b>	36560	2,2					
	5,7	1184	<b>255,83</b>	37604	2,5	<b>DR573-3E80M/4D</b>	1,77	157	116	IE3
	6,9	973	<b>209,81</b>	38745	3,1					
	7,5	893	<b>192,62</b>	39153	3,4					

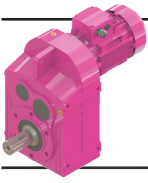

## D Serisi Motorlu Güç Devir Sayfaları

### D Series Geared Motors Performance Tables

#### D Serien Getriebemotoren Leistung und Drehzahlübersicht

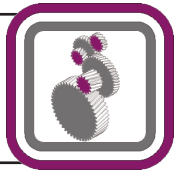

Güç	IE3 Çıkış Devri	IE3 Çıkış Momenti	Çevrim Oranı	IE3 Güv. Rad. Yük Çıkış Per.O. Loads (Output)	IE3 Servis Faktörü	Tipi	Anma Akımı	Ağırlık	Ölçü Sayfası	Motor Verim Snf.
Power	Output Speeds	Output Torque	Ratio	Per.O. Loads (Output)	Service Factors	Type	Rated Current	Weight	Dim. Page	Motor Eff. Class
Leistung P <sub>g</sub> [kW] P <sub>g</sub> [HP]	Abtriebswelle Drehzahlen n <sub>2</sub> [r.p.m]	Abtriebswelle Drehmomente M <sub>2</sub> [Nm]	Übersetzung i	Zul.Querkräfte (Abtrieb) F <sub>qam</sub> [N]	Betriebsfaktor f <sub>s</sub>	Typ	Nennstrom [A]	Gewicht ~ [kg]	Maße Seite	Motor Effizienz-klasse
0,75 1,0	3,9	1719	242,68	14462	0,9	DR473-3E90S/6B	1,96	118	110	IE3
	4,4	1523	215,03	17279	1,0					
	5,4	1241	174,97	20440	1,2					
	6,0	1124	242,68	21541	1,4	DR473-3E80M/4D	1,77	114	110	IE3
	6,7	996	215,03	22636	1,6					
	8,3	812	174,97	23993	1,9					
	9,4	718	154,63	24643	2,2					
	10	643	138,35	25137	2,4					
	12	565	121,49	25618	2,7					
	14	473	101,48	26156	3,3					
	15	447	95,87	26301	3,5					
7,8	861	121,67	11337	1,0	DR373-3E90S/6B	1,96	80	106	IE3	
	8,4	795	171,89	12348						1,0
	9,6	700	151,15	13643	1,2	DR373-3E80M/4D	1,77	76	106	IE3
	12	564	121,67	15190	1,5					
	14	495	106,69	15858	1,7					
	15	438	94,32	16351	1,9					
	18	369	79,34	16930	2,2					
	21	314	67,45	17353	2,6					
	25	269	57,79	17676	3,0					
	28	244	52,30	17851	3,4					
	11	628	135,52	8696	1,0	DR283-3E80M/4D	1,77	38	102	IE3
	12	553	119,16	10102	1,1					
	13	521	112,15	10623	1,2					
	15	445	95,92	11700	1,3					
	17	391	84,12	12378	1,5					
	19	346	74,36	12886	1,7					
	23	291	62,55	13428	2,1					
	27	248	53,18	13839	2,4					
	32	213	45,56	14151	2,8					
	35	193	41,23	14319	3,1					
	12	523	113,02	10747	0,9	DR273-3E80M/4D	1,77	31	98	IE3
	15	445	96,09	12036	1,0					
	17	387	83,46	12847	1,2					
	19	339	73,03	13443	1,3					
	24	281	60,39	14068	1,6					
	28	234	50,36	14532	1,9					
	34	197	42,22	14878	2,3					
	39	170	36,38	15110	2,7					
	47	142	30,34	15335	3,2					
	56	122	25,78	15487	3,7	DR272-3E80M/4D	1,77	29	98	IE3
	64	107	22,67	15748	4,0					
	68	101	21,33	15954	4,0					
	79	86	18,25	16375	4,0					
	32	208	44,66	5325	1,0	DR173-3E80M/4D	1,77	27	96	IE3
	38	176	37,75	5978	1,1					
	46	147	31,52	6460	1,4					
	53	127	27,18	6752	1,6					

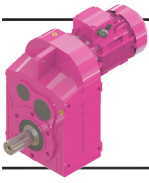

# D Serisi Motorlu Güç Devir Sayfaları

## D Series Geared Motors Performance Tables

### D Serien Getriebemotoren Leistung und Drehzahlübersicht



Güç	IE3 Çıkış Devri	IE3 Çıkış Momenti	Çevrim Oranı	IE3 Güv. Rad. Yük Çıkış Per.O. Loads (Output)	IE3 Servis Faktörü	Tipi	Anma Akımı	Ağırlık	Ölçü Sayfası	Motor Verim Snf.
Power	Output Speeds	Output Torque	Ratio	Per.O. Loads (Output)	Service Factors	Type	Rated Current	Weight	Dim. Page	Motor Eff. Class
Leistung P <sub>g</sub> [kW] P <sub>g</sub> [HP]	Abtriebswelle Drehzahlen n <sub>2</sub> [r.p.m]	Abtriebswelle Drehmomente M <sub>2</sub> [Nm]	Übersetzung i	Zul.Querkräfte (Abtrieb) F <sub>qam</sub> [N]	Betriebsfaktor f <sub>s</sub>	Typ	Nennstrom [A]	Gewicht ~ [kg]	Maße Seite	Motor Effizienz-klasse
0,75 1,0	67	103	21,79	6659	1,9	DR172-3E80M/4D	1,77	25	96	IE3
	76	90	19,04	6454	2,2					
	81	85	17,86	6356	2,4					
	96	72	15,18	6106	2,8					
	110	63	13,19	5889	3,2					
	126	55	11,54	5685	3,7					
	152	45	9,54	5398	4,0					
	33	207	44.60	1982	0.7	DR073-3E80M/4D	1,77	18	94	IE3
	38	178	38.18	2041	0.8					
	41	165	35.43	2059	0.9					
	39	173	36.86	2050	0.9	DR072-3E80M/4D	1,77	16	94	IE3
	47	145	30.71	2077	1.0					
	52	130	27.64	2078	1.1					
	58	118	25.01	2072	1.3					
	69	100	21.12	2048	1.5					
80	86	18.09	2014	1.8						
91	76	15.97	1979	2.0						
97	71	14.92	1959	2.1						
115	60	12.61	1903	2.5						
138	50	10.53	1837	3.0						
166	42	8.76	1736	3.6						
177	39	8.18	1711	3.9						
210	33	6.91	1648	4.0						
251	27	5.77	1578	4.0						
273	25	10.53	1562	4.0	DR072-3E80M/2B	1,59	17	94	IE3	
329	21	8.76	1474	4.0						
352	19	8.18	1447	4.0						
417	16	6.91	1383	4.0						
499	14	5.77	1315	4.0						
1,1 1,5	0,50	18476	2909,37	199202	1,0	DR976-3E90S/4C	2,46	798	144	IE3
	0,70	13473	2079,97	212586	1,3	DR975-3E90S/4C	2,46	798	144	IE3
	0,78	12105	1867,46	215840	1,5					
	0,91	10312	1591,90	219817	1,7					
	1,0	9098	1403,36	222332	2,0					
	1,2	8077	1244,98	224341	2,2					
	1,3	7207	1110,06	225980	2,5					
	1,5	6106	938,19	227956	2,9					
	0,62	15177	2356,74	62792	0,9	DR875-3E90S/4C	2,46	516	138	IE3
	0,71	13226	2051,67	75488	1,0					
	0,80	11707	1813,10	83461	1,1					
	0,89	10478	1622,25	89087	1,2					
	1,0	9217	1424,58	94234	1,4					
	1,2	7717	1189,85	99676	1,7					
	1,4	6795	1046,63	102551	1,9					
1,6	6032	928,31	104912	2,2						
1,7	5391	828,93	106787	2,4						
1,9	4844	744,27	108310	2,7						
0,96	9737	1507,38	40181	0,8	DR775-3E90S/4C	2,46	316	132	IE3	
1,1	8566	1323,71	51201	0,9						
1,3	7172	1105,59	61029	1,1						



# D Serisi Motorlu Güç Devir Sayfaları

## D Series Geared Motors Performance Tables

### D Serien Getriebemotoren Leistung und Drehzahlübersicht

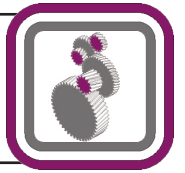

Güç	IE3 Çıkış Devri	IE3 Çıkış Momenti	Çevrim Oranı	IE3 Güv. Rad. Yük Çıkış Per.O. Loads (Output)	IE3 Servis Faktörü	Tipi	Anma Akımı	Ağırlık	Ölçü Sayfası	Motor Verim Snf.				
Power	Output Speeds	Output Torque	Ratio	Per.O. Loads (Output)	Service Factors	Type	Rated Current	Weight	Dim. Page	Motor Eff. Class				
Leistung P <sub>g</sub> [kW] P <sub>g</sub> [HP]	Abtriebswelle Drehzahlen n <sub>2</sub> [r.p.m]	Abtriebswelle Drehmomente M <sub>2</sub> [Nm]	Übersetzung i	Zul.Querkräfte (Abtrieb) F <sub>qam</sub> [N]	Betriebsfaktor f <sub>s</sub>	Typ	Nennstrom [A]	Gewicht ~ [kg]	Maße Seite	Motor Effizienz-klasse				
1,1 1,5	1,5	6489	<b>632,92</b>	65039	1,2	<b>DR774-3E90L/6C</b>	2,75	304	130	IE3				
	1,7	5811	<b>566,21</b>	68629	1,4									
	1,9	5019	<b>489,64</b>	72400	1,6									
	2,3	4207	<b>632,92</b>	75738	1,9	<b>DR774-3E90S/4C</b>	2,46	306	130	IE3				
	2,6	3767	<b>566,21</b>	77474	2,1									
	3,0	3254	<b>489,64</b>	79376	2,5									
	3,3	2912	<b>438,10</b>	80570	2,7									
	3,8	2562	<b>384,72</b>	81739	3,1									
	4,5	2145	<b>321,33</b>	83060	3,7									
	2,1	4476	<b>675,51</b>	27375	1,0						<b>DR674-3E90S/4C</b>	2,46	331	124
2,4	3992	<b>601,90</b>	32594	1,1										
2,8	3396	<b>512,73</b>	37544	1,3										
3,4	2818	<b>424,33</b>	41537	1,5										
4,0	2412	<b>362,91</b>	43892	1,8										
4,6	2119	<b>318,25</b>	45466	2,0										
5,2	1877	<b>281,35</b>	46699	2,3										
6,1	1582	<b>236,65</b>	48093	2,7										
2,9	3315	<b>499,72</b>	17181	0,9	<b>DR574-3E90S/4C</b>	2,46	167	118	IE3					
3,7	2673	<b>255,83</b>	26097	1,1										
4,5	2197	<b>209,81</b>	30672	1,4										
4,9	2016	<b>192,62</b>	32145	1,5	<b>DR573-3E90L/6C</b>	2,75	162	116	IE3					
5,7	1737	<b>255,83</b>	34201	1,7										
6,9	1428	<b>209,81</b>	36162	2,1										
7,5	1310	<b>192,62</b>	36873	2,3										
8,6	1149	<b>168,60</b>	37801	2,6										
9,7	1017	<b>149,15</b>	38512	2,9										
12	861	<b>126,06</b>	39313	3,5										
5,4	1833	<b>174,97</b>	12410	0,8						<b>DR473-3E90L/6C</b>	2,75	118	110	IE3
6,0	1650	<b>242,68</b>	15508	0,9										
6,7	1462	<b>215,03</b>	18039	1,1										
8,3	1192	<b>174,97</b>	20919	1,3	<b>DR473-3E90S/4C</b>	2,46	119	110	IE3					
9,4	1054	<b>154,63</b>	22151	1,5										
10	943	<b>138,35</b>	23015	1,6										
12	829	<b>121,49</b>	23909	1,9										
14	694	<b>101,48</b>	24807	2,2										
15	656	<b>95,87</b>	25054	2,4										
19	531	<b>154,63</b>	25810	2,9						<b>DR473-3E80M/2C</b>	2,26	114	110	IE3
21	475	<b>138,35</b>	26408	3,2										
10	1027	<b>151,15</b>	7865	0,8	<b>DR373-3E90S/4C</b>	2,46	81	106	IE3					
12	827	<b>121,67</b>	11884	1,0										
14	726	<b>106,69</b>	13303	1,1										
15	643	<b>94,32</b>	14330	1,3										
18	541	<b>79,34</b>	15416	1,5										
21	461	<b>67,45</b>	16176	1,8										
25	395	<b>57,79</b>	16714	2,1										
28	358	<b>52,30</b>	17016	2,3										

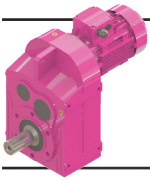

# D Serisi Motorlu Güç Devir Sayfaları

## D Series Geared Motors Performance Tables

### D Serien Getriebemotoren Leistung und Drehzahlübersicht



Güç	IE3 Çıkış Devri	IE3 Çıkış Momenti	Çevrim Oranı	IE3 Güv. Rad. Yük Çıkış Per.O. Loads (Output)	IE3 Servis Faktörü	Tipi	Anma Akımı	Ağırlık	Ölçü Sayfası	Motor Verim Snf.
Power	Output Speeds	Output Torque	Ratio	Per.O. Loads (Output)	Service Factors	Type	Rated Current	Weight	Dim. Page	Motor Eff. Class
Leistung P <sub>g</sub> [kW] P <sub>g</sub> [HP]	Abtriebswelle Drehzahlen n <sub>2</sub> [r.p.m]	Abtriebswelle Drehmomente M <sub>2</sub> [Nm]	Übersetzung i	Zul.Querkräfte (Abtrieb) F <sub>qam</sub> [N]	Betriebsfaktor f <sub>s</sub>	Typ	Nennstrom [A]	Gewicht ~ [kg]	Maße Seite	Motor Effizienz-klasse
1,1 1,5	35	284	41,42	17814	2,8	DR373-3E90S/4C	2,46	81	106	IE3
	41	244	35,49	18333	3,1					
	45	221	32,11	18617	3,3					
	13	764	112,15	4872	0,8	DR283-3E90S/4C	2,46	43	102	IE3
	15	654	95,92	8124	0,9					
	17	574	84,12	9765	1,0					
	19	508	74,36	10819	1,2					
	23	428	62,55	11927	1,4					
	27	364	53,18	12672	1,6					
	32	312	45,56	13217	1,9					
	35	283	41,23	13511	2,1					
	49	207	29,85	14199	2,9	DR282-3E90S/4C	2,46	40	102	IE3
	58	172	24,79	14484	3,5					
	17	568	83,46	9899	0,8	DR273-3E90S/4C	2,46	36	98	IE3
	19	498	73,03	11201	0,9					
	24	412	60,39	12511	1,1					
	28	344	50,36	13374	1,3					
	34	289	42,22	13983	1,6					
	39	249	36,38	14391	1,8					
	47	208	30,34	14778	2,2					
		56	179	25,78	15033					
64		157	22,67	15210	2,9					
68		148	21,33	15284	3,0					
79		127	18,25	15450	3,6					
90		111	16,00	15586	4,0					
102		98	14,14	15069	4,0					
121		83	11,90	14365	4,0					
		46	215	31,52	5167	0,9	DR173-3E90S/4C	2,46	32	96
	53	186	27,18	5772	1,1					
	67	151	21,79	6143	1,3	DR172-3E90S/4C	2,46	29	96	IE3
	76	132	19,04	6008	1,5					
	81	124	17,86	5939	1,6					
	96	106	15,18	5755	1,9					
	110	92	13,19	5587	2,2					
	126	80	11,54	5422	2,5					
	152	67	9,54	5182	3,0					
	187	54	7,74	4858	3,3					
	216	47	6,72	4688	3,6					
	247	41	5,88	4527	3,9					
	298	34	4,86	4300	4,0					
		58	173	25,01	1638					
69		146	21,12	1689	1,0					
80		126	18,09	1712	1,2					
91		111	15,97	1716	1,4					
97		104	14,92	1715	1,4					
115		88	12,61	1699	1,7					
138		73	10,53	1670	2,0					
166		61	8,76	1582	2,5					
177		57	8,18	1568	2,6					
210		48	6,91	1529	3,1					
251		40	5,77	1480	3,7					

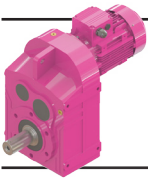

# D Serisi Motorlu Güç Devir Sayfaları

## D Series Geared Motors Performance Tables

### D Serien Getriebemotoren Leistung und Drehzahlübersicht

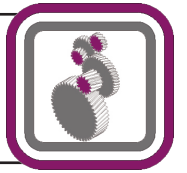

Güç	IE3 Çıkış Devri	IE3 Çıkış Momenti	Çevrim Oranı	IE3 Güv. Rad. Yük Çıkış Per.O. Loads (Output)	IE3 Servis Faktörü	Tipi	Anma Akımı	Ağırlık	Ölçü Sayfası	Motor Verim Snf.
Power	Output Speeds	Output Torque	Ratio	Per.O. Loads (Output)	Service Factors	Type	Rated Current	Weight	Dim. Page	Motor Eff. Class
Leistung P <sub>g</sub> [kW] P <sub>g</sub> [HP]	Abtriebswelle Drehzahlen n <sub>2</sub> [r.p.m]	Abtriebswelle Drehmomente M <sub>2</sub> [Nm]	Übersetzung i	Zul.Querkräfte (Abtrieb) F <sub>qam</sub> [N]	Betriebsfaktor f <sub>s</sub>	Typ	Nennstrom [A]	Gewicht ~ [kg]	Maße Seite	Motor Effizienz-klasse
1,1 1,5	273 329 352 417 499	37 31 29 24 20	10.53 8.76 8.18 6.91 5.77	1481 1400 1378 1325 1267	4.0 4.0 4.0 4.0 4.0	DR072-3E80M/2C	2,26	26	94	IE3
1,5 2,0	0,70 0,78 0,91 1,0 1,2 1,3 1,5	18372 16506 14061 12406 11014 9827 8326	2079,97 1867,46 1591,90 1403,36 1244,98 1110,06 938,19	199607 204963 211126 215140 218297 220838 223860	1,0 1,1 1,3 1,5 1,6 1,8 2,2	DR975-3E90L/4D	3,30	800	144	IE3
	1,8 2,3 2,6	7228 5744 5144	523,19 415,16 371,15	225963 228600 229612	2,5 3,1 3,5	DR974-3E100L/6B	3,50	797	142	IE3
	0,80 0,89 1,0 1,2 1,4	15964 14288 12569 10523 9266	1813,10 1622,25 1424,58 1189,85 1046,63	56766 69092 79094 88889 94046	0,8 0,9 1,0 1,2 1,4	DR875-3E90L/4D	3,30	518	138	IE3
	1,6 1,8 2,0 2,3 2,9 3,3 3,7	8363 7411 6657 5639 4630 4061 3593	607,27 537,22 482,05 407,42 334,15 293,46 259,15	97254 100572 103075 106098 108908 110391 111563	1,6 1,8 2,0 2,3 2,8 3,2 3,6	DR874-3E100L/6B	3,50	515	136	IE3
	1,5 1,7 2,0	8710 7800 6736	632,92 566,21 489,64	50148 56906 63642	0,9 1,0 1,2	DR774-3E100L/6B	3,50	314	130	IE3
	2,3 2,6 3,0 3,3 3,8	5737 5137 4437 3971 3493	632,92 566,21 489,64 438,10 384,72	69006 71865 74917 76683 78505	1,4 1,6 1,8 2,0 2,3	DR774-3E90L/4D	3,30	305	130	IE3
	4,3 5,0 6,0	3124 2678 2228	222,16 190,20 158,23	79856 81373 82813	2,6 3,0 3,6	DR773-3E100L/6B	3,50	294	128	IE3
	2,8 3,4 4,0	4631 3843 3289	512,73 424,33 362,91	25407 33994 38339	0,9 1,1 1,3	DR674-3E90L/4D	3,30	233	124	IE3
	4,3 4,8 5,7 6,8 7,7 7,7	3111 2771 2365 1969 1756 1756	221,47 197,01 167,96 139,76 124,53 124,53	39600 41834 44147 46253 47295 47295	1,4 1,6 1,8 2,2 2,4 2,4	DR673-3E100L/6B	3,50	232	122	IE3

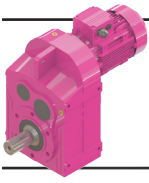

## D Serisi Motorlu Güç Devir Sayfaları

### D Series Geared Motors Performance Tables

#### D Serien Getriebemotoren Leistung und Drehzahlübersicht



Güç	IE3 Çıkış Devri	IE3 Çıkış Momenti	Çevrim Oranı	IE3 Güv. Rad. Yük Çıkış	IE3 Servis Faktörü	Tipi	Anma Akımı	Ağırlık	Ölçü Sayfası	Motor Verim Sınıfı				
Power	Output Speeds	Output Torque	Ratio	Per.O. Loads (Output)	Service Factors	Type	Rated Current	Weight	Dim. Page	Motor Eff. Class				
Leistung P <sub>g</sub> [kW] P <sub>g</sub> [HP]	Abtriebswelle Drehzahlen n <sub>2</sub> [r.p.m]	Abtriebswelle Drehmomente M <sub>2</sub> [Nm]	Übersetzung i	Zul.Querkräfte (Abtrieb) F <sub>qam</sub> [N]	Betriebsfaktor f <sub>s</sub>	Typ	Nennstrom [A]	Gewicht ~ [kg]	Maße Seite	Motor Effizienz-klasse				
1,5 2,0	4,6	2948	<b>209,81</b>	22865	1,0	<b>DR573-3E100L/6B</b>	3,50	171	116	IE3				
	5,7	2371	<b>255,83</b>	29124	1,3	<b>DR573-3E90L/4D</b>	3,30	163	116	IE3				
	6,9	1949	<b>209,81</b>	32665	1,5									
	7,5	1789	<b>192,62</b>	33841	1,7									
	8,6	1568	<b>168,60</b>	35330	1,9									
	9,7	1389	<b>149,15</b>	36403	2,2									
	12	1175	<b>126,06</b>	37652	2,6									
	14	973	<b>209,81</b>	38746	3,1	<b>DR573-3E90S/2B</b>	2,97	161	116	IE3				
	15	893	<b>192,62</b>	39154	3,4									
	6,7	1995	<b>215,03</b>	8539	0,8	<b>DR473-3E90L/4D</b>	3,30	119	110	IE3				
	8,3	1627	<b>174,97</b>	15860	1,0									
	9,4	1439	<b>154,63</b>	18308	1,1									
	10	1288	<b>138,35</b>	19974	1,2									
	12	1132	<b>121,49</b>	21470	1,4									
	14	947	<b>101,48</b>	22984	1,6									
	15	895	<b>95,87</b>	23411	1,7									
	19	718	<b>154,63</b>	24649	2,2						<b>DR473-3E90S/2B</b>	2,97	117	110
	21	643	<b>138,35</b>	25448	2,3									
	24	565	<b>121,49</b>	26250	2,5									
14	991	<b>106,69</b>	8750	0,8	<b>DR373-3E90L/4D</b>	3,30	83	106	IE3					
15	877	<b>94,32</b>	11036	0,9										
18	739	<b>79,34</b>	13135	1,1										
21	629	<b>67,45</b>	14486	1,3										
25	540	<b>57,79</b>	15433	1,5										
28	489	<b>52,30</b>	15922	1,7										
35	388	<b>41,42</b>	17054	2,0										
41	333	<b>35,49</b>	17753	2,2										
45	301	<b>32,11</b>	18127	2,4										
57	241	<b>25,42</b>	17870	3,4						<b>DR373-3E90L/4D</b>	3,30	77	106	IE3
65	213	<b>22,46</b>	18054	3,8										
19	693	<b>74,36</b>	7173	0,9	<b>DR283-3E90L/4D</b>	3,30	45	102	IE3					
23	584	<b>62,55</b>	9579	1,0										
27	497	<b>53,18</b>	10980	1,2										
32	426	<b>45,56</b>	11945	1,4										
35	386	<b>41,23</b>	12434	1,6										
49	283	<b>29,85</b>	13513	2,1						<b>DR282-3E90L/4D</b>	3,30	42	102	IE3
58	235	<b>24,79</b>	13955	2,6										
68	202	<b>21,28</b>	14243	3,0										
77	178	<b>18,73</b>	14519	3,3										
24	562	<b>60,39</b>	10018	0,8	<b>DR273-3E90L/4D</b>	3,30	38	98	IE3					
28	470	<b>50,36</b>	11658	1,0										
34	394	<b>42,22</b>	12752	1,1										
39	340	<b>36,38</b>	13428	1,3										
47	284	<b>30,34</b>	14035	1,6										

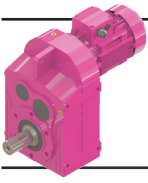

## D Serisi Motorlu Güç Devir Sayfaları

### D Series Geared Motors Performance Tables

#### D Serien Getriebemotoren Leistung und Drehzahlübersicht



Güç	IE3 Çıkış Devri	IE3 Çıkış Momenti	Çevrim Oranı	IE3 Güv. Rad. Yük Çıkış Per.O. Loads (Output)	IE3 Servis Faktörü	Tipi	Anma Akımı	Ağırlık	Ölçü Sayfası	Motor Verim Snf.						
Power	Output Speeds	Output Torque	Ratio	Per.O. Loads (Output)	Service Factors	Type	Rated Current	Weight	Dim. Page	Motor Eff. Class						
Leistung P <sub>g</sub> [kW] P <sub>g</sub> [HP]	Abtriebswelle Drehzahlen n <sub>2</sub> [r.p.m]	Abtriebswelle Drehmomente M <sub>2</sub> [Nm]	Übersetzung i	Zul.Querkräfte (Abtrieb) F <sub>qam</sub> [N]	Betriebsfaktor f <sub>s</sub>	Typ	Nennstrom [A]	Gewicht ~ [kg]	Maße Seite	Motor Effizienz-klasse						
1,5 2,0	56	244	25,78	14440	1,8	DR272-3E90L/4D	3,30	36	98	IE3						
	64	215	22,67	14715	2,1											
	68	202	21,33	14829	2,2											
	79	173	18,25	15081	2,6											
	90	152	16,00	15254	3,0											
	102	134	14,14	14870	3,3											
	121	113	11,90	14198	4,0											
	143	96	10,11	13587	4,0											
	67	207	21,79	5372	1,0						DR172-3E90L/4D	3,30	31	96	IE3	
	76	181	19,04	5477	1,1											
81	169	17,86	5444	1,2												
96	144	15,18	5340	1,4												
110	125	13,19	5230	1,6												
126	110	11,54	5113	1,8												
152	91	9,54	4929	2,2												
187	74	7,74	4631	2,4												
216	64	6,72	4492	2,7												
247	56	5,88	4357	2,9												
298	46	4,86	4161	3,1												
1,5 2,0	69	200	21.12	1248	0.8	DR072-3E90L/4D	3,30	26	94	IE3						
	80	172	18.09	1343	0.9											
	91	152	15.97	1397	1.0											
	97	142	14.92	1419	1.1											
	115	120	12.61	1455	1.3											
	138	100	10.53	1469	1.5											
	166	83	8.76	1398	1.8											
	177	78	8.18	1397	1.9											
	210	66	6.91	1386	2.3											
	251	55	5.77	1363	2.7											
1,5 2,0	275	50	10.53	1385	3.0	DR072-3E90S/2B	2,97	27	94	IE3						
	331	42	8.76	1311	3.6											
	355	39	8.18	1296	3.9											
	419	33	6.91	1256	4.0											
	502	27	5.77	1210	4.0											
	2,2 3,0	0,91	20623	1591,90	192317						0,9	DR975-3E100L/4C	4,65	805	144	IE3
		1,0	18196	1403,36	200150						1,0					
		1,2	16154	1244,98	205776						1,1					
		1,3	14413	1110,06	210362						1,2					
		1,5	12211	938,19	215691						1,5					
1,7		11244	864,41	217874	1,6											
1,8		10492	523,19	219470	1,7	DR974-3E112M/6B	4,95	801	142	IE3						
2,3		8338	415,16	223866	2,2											
2,6		7467	371,15	225522	2,4											
2,8		6982	523,19	226435	2,6	DR974-3E100L/4C	4,65	799	142	IE3						
3,5	5549	415,16	228949	3,2												
3,9	4969	371,15	229915	3,6												
1,2	15434	1189,85	61236	0,8	DR875-3E100L/4C	4,65	825	138	IE3							
1,4	13590	1046,63	73373	1,0												
1,6	12139	607,27	81321	1,1	DR874-3E112M/6B	4,95	521	136	IE3							
1,8	10757	537,22	87867	1,2												

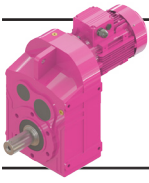

# D Serisi Motorlu Güç Devir Sayfaları

## D Series Geared Motors Performance Tables

### D Serien Getriebemotoren Leistung und Drehzahlübersicht



Güç	IE3 Çıkış Devri	IE3 Çıkış Momenti	Çevrim Oranı	IE3 Güv. Rad. Yük Çıkış Per.O. Loads (Output)	IE3 Servis Faktörü	Tipi	Anma Akımı	Ağırlık	Ölçü Sayfası	Motor Verim Snf.
Power	Output Speeds	Output Torque	Ratio	Per.O. Loads (Output)	Service Factors	Type	Rated Current	Weight	Dim. Page	Motor Eff. Class
Leistung P <sub>g</sub> [kW] P <sub>g</sub> [HP]	Abtriebswelle Drehzahlen n <sub>2</sub> [r.p.m]	Abtriebswelle Drehmomente M <sub>2</sub> [Nm]	Übersetzung i	Zul.Querkräfte (Abtrieb) F <sub>qam</sub> [N]	Betriebsfaktor f <sub>s</sub>	Typ	Nennstrom [A]	Gewicht ~ [kg]	Maße Seite	Motor Effizienz-klasse
2,2 3,0	2,0	9662	482,05	92483	1,3	DR874-3E112M/6B	4,95	521	136	IE3
	2,4	8184	407,42	97896	1,6					
	2,4	8079	607,27	98328	1,6	DR874-3E100L/4C	4,65	520	136	IE3
	2,7	7159	537,22	101567	1,8					
	3,0	6430	482,05	103767	2,0					
	3,6	5447	407,42	106680	2,4					
	4,3	4472	334,15	109347	2,9					
	4,9	3923	293,46	110787	3,3					
	5,6	3470	259,15	111876	3,7					
	2,3	8414	632,92	52382	1,0	DR774-3E100L/4C	4,65	312	130	IE3
	2,6	7535	566,21	58704	1,1					
	3,0	6507	489,64	64817	1,2					
	3,3	5824	438,10	68465	1,4					
	3,8	5124	384,72	71927	1,6					
	4,3	4540	222,16	74383	1,8	DR773-3E112M/6B	4,95	298	128	IE3
	5,1	3892	190,20	77017	2,1					
	6,1	3239	158,23	79451	2,5					
	6,5	3030	222,16	80200	2,6	DR773-3E100L/4C	4,65	298	128	IE3
	7,6	2598	190,20	81650	3,1					
	9,2	2162	158,23	83029	3,7					
	4,4	4522	221,47	26935	1,0	DR673-3E112M/6B	4,95	236	122	IE3
	4,9	4027	197,01	32204	1,1					
	5,7	3438	167,96	37227	1,3					
	6,5	3018	221,47	40162	1,4	DR673-3E100L/4C	4,65	236	122	IE3
	7,4	2688	197,01	42343	1,6					
	8,6	2295	167,96	44618	1,9					
	10	1910	139,76	46564	2,3					
	12	1704	124,53	47556	2,5					
	5,7	3446	168,60	14530	0,9	DR573-3E112M/6B	4,95	175	116	IE3
	6,5	3052	149,15	21427	1,0					
	6,9	2859	209,81	23940	1,0	DR573-3E100L/4C	4,65	175	116	IE3
	7,5	2625	192,62	26616	1,1					
	8,6	2300	168,60	29696	1,3					
	9,7	2038	149,15	31920	1,5					
	12	1725	126,06	34288	1,7					
	14	1415	103,39	36314	2,1					
	16	1251	91,30	37243	2,4					
	18	1113	81,15	38016	2,7					
	21	943	68,64	38915	3,2					
	24	841	61,12	39427	3,6					
		10	1889	138,35	11205					
12		1661	121,49	15352	0,9					
14		1390	101,48	18876	1,1					
15		1314	95,87	19655	1,2					
18		1110	81,00	21633	1,4					
21		969	70,59	23211	1,5					
23		850	61,85	24515	1,7					
27	747	54,35	25371	1,9						

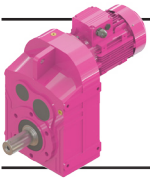

# D Serisi Motorlu Güç Devir Sayfaları

## D Series Geared Motors Performance Tables

### D Serien Getriebemotoren Leistung und Drehzahlübersicht



Güç	IE3 Çıkış Devri	IE3 Çıkış Momenti	Çevrim Oranı	IE3 Güv. Rad. Yük Çıkış Per.O. Loads (Output)	IE3 Servis Faktörü	Tipi	Anma Akımı	Ağırlık	Ölçü Sayfası	Motor Verim Snf.
Power	Output Speeds	Output Torque	Ratio	Per.O. Loads (Output)	Service Factors	Type	Rated Current	Weight	Dim. Page	Motor Eff. Class
Leistung P <sub>g</sub> [kW] P <sub>g</sub> [HP]	Abtriebswelle Drehzahlen n <sub>2</sub> [r.p.m]	Abtriebswelle Drehmomente M <sub>2</sub> [Nm]	Übersetzung i	Zul.Querkräfte (Abtrieb) F <sub>qam</sub> [N]	Betriebsfaktor f <sub>s</sub>	Typ	Nennstrom [A]	Gewicht ~ [kg]	Maße Seite	Motor Effizienz-klasse
2,2 3,0	31	652	47,37	26277	2,1	DR473-3E100L/4C	4,65	124	110	IE3
	35	572	41,50	27013	2,3					
	42	473	34,28	27850	2,6					
	21	923	67,45	10194	0,9	DR373-3E100L/4C	4,65	88	106	IE3
	25	792	57,79	12393	1,0					
	28	717	52,30	13389	1,1					
	35	569	41,42	15466	1,4					
	41	488	35,49	16597	1,5					
	45	442	32,11	17144	1,6					
	53	379	27,53	17886	1,8					
	57	354	25,42	17057	2,3	DR372-3E100L/4C	4,65	82	106	IE3
	65	313	22,46	17367	2,6					
	72	280	20,10	17606	2,9					
	82	246	17,65	17841	3,3					
	27	729	53,18	6107	0,8	DR283-3E100L/4C	4,65	50	102	IE3
	32	626	45,56	8745	1,0					
	35	567	41,23	9864	1,1					
	41	486	35,35	11121	1,2					
	48	417	30,28	12173	1,4					
	58	345	24,79	12895	1,7					
	68	296	21,28	13389	2,0					
77	261	18,73	13820	2,3						
87	232	16,62	14290	2,4						
103	196	14,06	14870	2,7						
121	168	12,03	15297	2,9						
140	145	10,38	15617	3,2						
153	132	9,45	15800	3,3						
177	115	8,19	15645	3,6						
34	578	42,22	9662	0,8	DR273-3E100L/4C	4,65	43	98	IE3	
39	499	36,38	11181	0,9						
47	417	30,34	12427	1,1						
57	350	25,44	13425	1,3						
64	315	22,67	13703	1,4	DR272-3E100L/4C	4,65	41	98	IE3	
68	297	21,33	13906	1,5						
79	254	18,25	14351	1,8						
90	223	16,00	14648	2,0						
102	197	14,14	14519	2,3						
121	166	11,90	13904	2,7						
143	141	10,11	13337	3,0						
167	121	8,67	12809	3,3						
212	96	6,84	11975	3,3						
249	82	5,82	11465	3,6						
291	70	4,98	10993	3,9						
81	249	17,86	4278	0,8	DR172-3E100L/4C	4,65	36	96	IE3	
96	212	15,18	4576	0,9						
110	184	13,19	4576	1,1						
126	161	11,54	4548	1,2						
152	133	9,54	4470	1,5						
187	108	7,74	4218	1,7						
216	94	6,72	4138	1,8						
247	82	5,88	4050	1,9						
298	68	4,86	3911	2,1						

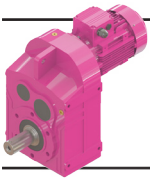

## D Serisi Motorlu Güç Devir Sayfaları

### D Series Geared Motors Performance Tables

#### D Serien Getriebemotoren Leistung und Drehzahlübersicht



Güç	IE3 Çıkış Devri	IE3 Çıkış Momenti	Çevrim Oranı	IE3 Güv. Rad. Yük Çıkış	IE3 Servis Faktörü	Tipi	Anma Akımı	Ağırlık	Ölçü Sayfası	Motor Verim Snf.
Power	Output Speeds	Output Torque	Ratio	Per. O. Loads (Output)	Service Factors	Type	Rated Current	Weight	Dim. Page	Motor Eff. Class
Leistung P <sub>g</sub> [kW] P <sub>g</sub> [HP]	Abtriebswelle Drehzahlen n <sub>2</sub> [r.p.m]	Abtriebswelle Drehmomente M <sub>2</sub> [Nm]	Übersetzung i	Zul. Querkräfte (Abtrieb) F <sub>qam</sub> [N]	Betriebsfaktor f <sub>s</sub>	Typ	Nennstrom [A]	Gewicht ~ [kg]	Maße Seite	Motor Effizienz-klasse
2,2 3,0	375	54	7,74	3728	2,7	DR172-3E90L/2C	4,25	29	96	IE3
	431	47	6,72	3610	2,9					
	493	41	5,88	3497	3,2					
	596	34	4,86	3335	3,4					
	91	223	15,97	784	0,7	DR072-3E100L/4C	4,65	25	94	IE3
	97	208	14,92	855	0,7					
	115	176	12,61	993	0,9					
	138	147	10,53	1094	1,0					
	166	122	8,76	1050	1,2					
	177	114	8,18	1075	1,3					
	210	97	6,91	1121	1,6					
	251	81	5,77	1147	1,9					
275	74	10,53	1212	2,0	DR072-3E90L/2C	4,25	26	94	IE3	
331	61	8,76	1152	2,5						
355	57	8,18	1148	2,6						
419	48	6,91	1133	3,1						
502	40	5,77	1109	3,7						
3,0 4,0	1,2	22028	1244,98	187523	0,8	DR975-3E100L/4D	6,26	806	144	IE3
	1,3	19655	1110,06	195673	0,9					
	1,5	16652	938,19	204401	1,1					
	1,7	15333	864,41	207981	1,2					
	1,9	14233	523,19	210931	1,3	DR974-3E132S/6B	6,55	819	142	IE3
	2,3	11311	415,16	217867	1,6					
	2,6	10130	371,15	220349	1,8					
	2,8	9521	523,19	221538	1,9	DR974-3E100L/4D	6,26	801	142	IE3
	3,5	7567	415,16	225359	2,4					
	3,9	6776	371,15	226807	2,7					
	4,4	6091	333,23	228020	3,0					
	5,1	5192	284,06	229548	3,5					
	1,6	16451	928,31	52631	0,8					
	1,7	14701	828,93	66292	0,9					
	1,9	13210	744,27	75580	1,0					
	2,4	11016	607,27	86527	1,2	DR874-3E100L/4D	6,26	516	136	IE3
	2,7	9762	537,22	91940	1,3					
	3,0	8768	482,05	95901	1,5					
	3,6	7427	407,42	100563	1,8					
	4,3	6098	334,15	104776	2,1					
	4,9	5350	293,46	106956	2,4					
	5,6	4732	259,15	108655	2,7					
	6,4	4127	225,61	110243	3,2					
	2,6	10274	566,21	33564	0,8					
3,0	8873	489,64	48595	0,9						
3,3	7942	438,10	55907	1,0						
3,8	6987	384,72	62014	1,1						
4,4	6153	222,16	66852	1,3	DR773-3E132S/6B	6,55	318	128	IE3	
5,1	5275	190,20	71217	1,5						
6,1	4390	158,23	75104	1,8						

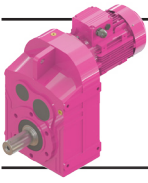

## D Serisi Motorlu Güç Devir Sayfaları

### D Series Geared Motors Performance Tables

#### D Serien Getriebemotoren Leistung und Drehzahlübersicht



Güç	IE3 Çıkış Devri	IE3 Çıkış Momenti	Çevrim Oranı	IE3 Güv. Rad. Yük Çıkış Per.O. Loads (Output)	IE3 Servis Faktörü	Tipi	Anma Akımı	Ağırlık	Ölçü Sayfası	Motor Verim Snf.
Power	Output Speeds	Output Torque	Ratio	Per.O. Loads (Output)	Service Factors	Type	Rated Current	Weight	Dim. Page	Motor Eff. Class
Leistung P <sub>g</sub> [kW] P <sub>g</sub> [HP]	Abtriebswelle Drehzahlen n <sub>2</sub> [r.p.m]	Abtriebswelle Drehmomente M <sub>2</sub> [Nm]	Übersetzung i	Zul.Querkräfte (Abtrieb) F <sub>qam</sub> [N]	Betriebsfaktor f <sub>s</sub>	Typ	Nennstrom [A]	Gewicht ~ [kg]	Maße Seite	Motor Effizienz-klasse
3,0 4,0	6,5	4135	<b>222,16</b>	76089	1,9	<b>DR773-3E100L/4D</b>	6,26	319	128	IE3
	7,6	3545	<b>190,20</b>	78360	2,3					
	9,2	2950	<b>158,23</b>	80474	2,7					
	10	2642	<b>141,55</b>	81498	3,0					
	5,8	4660	<b>167,96</b>	25164	0,9	<b>DR673-3E132S/6B</b>	6,55	254	122	IE3
	6,5	4118	<b>221,47</b>	31316	1,0	<b>DR673-3E100L/4D</b>	6,26	236	122	IE3
	7,4	3668	<b>197,01</b>	35396	1,2					
	8,6	3131	<b>167,96</b>	39385	1,4					
	10	2607	<b>139,76</b>	42832	1,6					
	12	2325	<b>124,53</b>	44444	1,8					
14	1928	<b>69,18</b>	46507	2,2	<b>DR673-3E132S/6B</b>	6,55	254	122	IE3	
16	1697	<b>60,82</b>	47615	2,5						
16	1655	<b>59,34</b>	47810	2,6						
19	1425	<b>51,01</b>	48832	3,0						
22	1238	<b>44,27</b>	49622	3,5						
25	1084	<b>38,70</b>	50245	4,0						
7,5	3581	<b>192,62</b>	11083	0,8	<b>DR573-3E100L/4D</b>	6,26	176	116	IE3	
8,6	3139	<b>168,60</b>	20186	1,0						
9,7	2780	<b>149,15</b>	24889	1,1						
12	2353	<b>126,06</b>	29214	1,3						
14	1931	<b>103,39</b>	32746	1,6						
16	1708	<b>91,30</b>	34348	1,8						
18	1519	<b>81,15</b>	35651	2,0						
21	1287	<b>68,64</b>	37037	2,3						
24	1147	<b>61,12</b>	37830	2,6						
29	942	<b>50,13</b>	38922	3,2						
33	833	<b>44,27</b>	39467	3,6						
14	1896	<b>101,48</b>	11053	0,8	<b>DR473-3E100L/4D</b>	6,26	124	110	IE3	
15	1792	<b>95,87</b>	13215	0,9						
18	1515	<b>81,00</b>	17384	1,0						
21	1322	<b>70,59</b>	20090	1,1						
23	1159	<b>61,85</b>	22159	1,2						
27	1020	<b>54,35</b>	23542	1,4						
31	890	<b>47,37</b>	24882	1,5						
35	781	<b>41,50</b>	25887	1,7						
42	646	<b>34,28</b>	27043	1,9						
59	468	<b>24,54</b>	26195	3,3						<b>DR472-3E100L/4D</b>
70	396	<b>20,74</b>	26586	3,9						
28	978	<b>52,30</b>	9067	0,8	<b>DR373-3E100L/4D</b>	6,26	89	106	IE3	
35	777	<b>41,42</b>	13097	1,0						
41	666	<b>35,49</b>	14874	1,1						
45	604	<b>32,11</b>	15762	1,2						
53	517	<b>27,53</b>	16884	1,3						
57	483	<b>25,42</b>	15976	1,7	<b>DR372-3E100L/4D</b>	6,26	83	106	IE3	
65	427	<b>22,46</b>	16456	1,9						
72	382	<b>20,10</b>	16831	2,1						
82	336	<b>17,65</b>	17195	2,4						
98	281	<b>14,74</b>	17599	2,9						
107	259	<b>13,60</b>	17753	3,2						

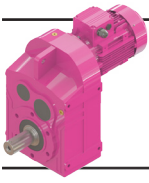

# D Serisi Motorlu Güç Devir Sayfaları

## D Series Geared Motors Performance Tables

### D Serien Getriebemotoren Leistung und Drehzahlübersicht



Güç	IE3 Çıkış Devri	IE3 Çıkış Momenti	Çevrim Oranı	IE3 Güv. Rad. Yük Çıkış Per.O. Loads (Output)	IE3 Servis Faktörü	Tipi	Anma Akımı	Ağırlık	Ölçü Sayfası	Motor Verim Snf.
Power	Output Speeds	Output Torque	Ratio	Per.O. Loads (Output)	Service Factors	Type	Rated Current	Weight	Dim. Page	Motor Eff. Class
Leistung P <sub>g</sub> [kW] P <sub>g</sub> [HP]	Abtriebswelle Drehzahlen n <sub>2</sub> [r.p.m]	Abtriebswelle Drehmomente M <sub>2</sub> [Nm]	Übersetzung i	Zul.Querkräfte (Abtrieb) F <sub>qam</sub> [N]	Betriebsfaktor f <sub>s</sub>	Typ	Nennstrom [A]	Gewicht ~ [kg]	Maße Seite	Motor Effizienz- klasse
3,0 4,0	123	224	11,77	17289	3,5	DR372-3E100L/4D	6,26	83	106	IE3
	41	663	35,35	7964	0,9	DR283-3E100L/4D	6,26	51	102	IE3
	48	568	30,28	10008	1,0					
	58	471	24,79	11328	1,3	DR282-3E100L/4D	6,26	47	102	IE3
	68	404	21,28	12200	1,5					
	77	356	18,73	12877	1,7					
	87	316	16,62	13534	1,8					
	103	268	14,06	14319	2,0					
	121	230	12,03	14882	2,1					
	140	198	10,38	15296	2,3					
153	181	9,45	15527	2,4						
177	156	8,19	15438	2,6						
205	136	7,09	14856	2,8						
218	127	6,65	14541	2,7						
253	110	5,74	13977	2,9						
278	100	5,22	13623	3,0						
321	87	4,52	13099	3,2						
370	75	3,92	12587	3,5						
47	568	30,34	9874	0,8	DR273-3E100L/4D	6,26	43	98	IE3	
	57	477	25,44	11697						0,9
64	430	22,67	12231	1,0	DR272-3E100L/4D	6,26	41	98	IE3	
	68	405	21,33	12585						1,1
	79	347	18,25	13341						1,3
	90	304	16,00	13837						1,5
	102	269	14,14	14112						1,7
	121	227	11,90	13563						2,0
	143	193	10,11	13049						2,2
	167	166	8,67	12563						2,4
	212	131	6,84	11762						2,4
	249	111	5,82	11284						2,7
291	95	4,98	10839	2,9						
336	82	8,67	10475	3,9	DR272-3E100L/2C	5,58	41	98	IE3	
	426	65	6,84	9787						4,0
	501	55	5,82	9361						4,0
	584	47	4,98	8969						4,0
110	251	13,19	3782	0,8	DR172-3E100L/4D	6,26	36	96	IE3	
	126	220	11,54	3865						0,9
	152	182	9,54	3919						1,1
	187	148	7,74	3720						1,2
	216	128	6,72	3712						1,3
	247	112	5,88	3683						1,4
	298	93	4,86	3613						1,6
	377	73	7,74	3492						2,0
434		64	6,72	3407	2,1					
496		56	5,88	3320	2,3					
599		46	4,86	3189	2,5					
138	201	10,53	570	0,7	DR072-3E100L/4D	6,26	33	94	IE3	
	166	167	8,76	552						0,9
	177	156	8,18	676						1,0

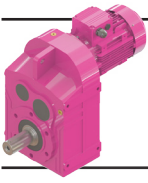

## D Serisi Motorlu Güç Devir Sayfaları

### D Series Geared Motors Performance Tables

#### D Serien Getriebemotoren Leistung und Drehzahlübersicht

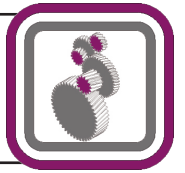

Güç	IE3 Çıkış Devri	IE3 Çıkış Momenti	Çevrim Oranı	IE3 Güv. Rad. Yük Çıkış Per.O. Loads (Output)	IE3 Servis Faktörü	Tipi	Anma Akımı	Ağırlık	Ölçü Sayfası	Motor Verim Snf.					
Power	Output Speeds	Output Torque	Ratio	Per.O. Loads (Output)	Service Factors	Type	Rated Current	Weight	Dim. Page	Motor Eff. Class					
Leistung P <sub>g</sub> [kW] P <sub>g</sub> [HP]	Abtriebswelle Drehzahlen n <sub>2</sub> [r.p.m]	Abtriebswelle Drehmomente M <sub>2</sub> [Nm]	Übersetzung i	Zul.Querkräfte (Abtrieb) F <sub>qam</sub> [N]	Betriebsfaktor f <sub>s</sub>	Typ	Nennstrom [A]	Gewicht ~ [kg]	Maße Seite	Motor Effizienz-klasse					
3,0 4,0	210	132	6.91	791	1.1	DR072-3E100L/4D	6,26	32	94	IE3					
	251	110	5.77	880	1.4										
	277	100	10.53	1005	1.5	DR072-3E100L/2C	5,58	33	94	IE3					
	333	83	8.76	960	1.8										
	356	78	8.18	970	1.9										
	422	66	6.91	985	2.3										
	505	55	5.77	988	2.7										
	505	55	5.77	988	2.7										
4,0 5,5	1,9	18977	523,19	197747	0,9	DR974-3E132M/6C	8,52	823	142	IE3					
	2,3	15082	415,16	208766	1,2										
	2,6	13506	371,15	212724	1,3										
	2,8	12608	523,19	214667	1,4	DR974-3E112M/4D	8,05	813	142	IE3					
	3,5	10020	415,16	220435	1,8										
	3,9	8973	371,15	222584	2,0										
	4,4	8065	333,23	224365	2,2										
	5,1	6875	284,06	226587	2,6										
	5,8	6069	250,41	228022	3,0										
	6,6	5390	222,15	229185	3,3										
	7,4	4811	197,95	228968	3,7										
	2,4	14588	607,27	67056	0,9						DR874-3E112M/4D	8,05	524	136	IE3
	2,7	12927	537,22	77163	1,0										
3,0	11611	482,05	83925	1,1											
3,6	9835	407,42	91781	1,3											
4,4	8075	334,15	98437	1,6											
5,0	7084	293,46	101618	1,8											
5,6	6267	259,15	104202	2,1											
6,5	5465	225,61	106576	2,4											
	7,6	4757	128,20	108689	2,7	DR873-3E132M/6C	8,52	527	134	IE3					
	8,4	4273	115,03	109905	3,0										
	9,6	3749	101,03	111224	3,5										
	11	3269	87,95	112387	4,0										
	4,4	8212	222,16	53965	1,0	DR773-3E132M/6C	8,52	322	128	IE3					
	5,1	7040	190,20	61827	1,1										
	6,1	5859	158,23	68379	1,4										
	11	3038	81,72	80178	2,6										
	13	2698	72,50	81433	3,0										
	6,6	5477	222,16	70275	1,5	DR773-3E112M/4D	8,05	308	128	IE3					
	7,7	4696	190,20	73725	1,7										
	9,2	3908	158,23	76929	2,0										
	10	3500	141,55	78480	2,3										
	7,4	4858	197,01	22387	0,9	DR673-3E112M/4D	8,05	237	122	IE3					
	8,7	4148	167,96	31041	1,0										
	10	3453	139,76	37109	1,2										
	12	3080	124,53	39813	1,4										
	14	2573	69,18	43022	1,7	DR673-3E132M/6C	8,52	258	122	IE3					
	16	2209	59,34	45068	1,9										
	19	1902	51,01	46637	2,3										
	22	1653	44,27	47819	2,6										
	25	1447	38,70	48713	3,0										

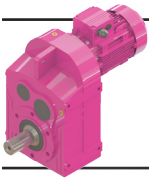

## D Serisi Motorlu Güç Devir Sayfaları

### D Series Geared Motors Performance Tables

#### D Serien Getriebemotoren Leistung und Drehzahlübersicht



Güç	IE3 Çıkış Devri	IE3 Çıkış Momenti	Çevrim Oranı	IE3 Güv. Rad. Yük Çıkış Per.O. Loads (Output)	IE3 Servis Faktörü	Tipi	Anma Akımı	Ağırlık	Ölçü Sayfası	Motor Verim Snf.	
Power	Output Speeds	Output Torque	Ratio	Per.O. Loads (Output)	Service Factors	Type	Rated Current	Weight	Dim. Page	Motor Eff. Class	
Leistung P <sub>g</sub> [kW] P <sub>g</sub> [HP]	Abtriebswelle Drehzahlen n <sub>2</sub> [r.p.m]	Abtriebswelle Drehmomente M <sub>2</sub> [Nm]	Übersetzung i	Zul.Querkräfte (Abtrieb) F <sub>qam</sub> [N]	Betriebsfaktor f <sub>s</sub>	Typ	Nennstrom [A]	Gewicht ~ [kg]	Maße Seite	Motor Effizienz-klasse	
4,0 5,5	29	1273	<b>34,02</b>	49524	3,4	<b>DR673-3E132M/6C</b>	8,52	258	122	IE3	
	12	3118	<b>126,06</b>	20356	1,0	<b>DR573-3E112M/4D</b>	8,05	184	116	IE3	
	14	2558	<b>103,39</b>	27305	1,2						
	16	2262	<b>91,30</b>	30108	1,3						
	18	2013	<b>81,15</b>	32171	1,5						
	21	1705	<b>68,64</b>	34424	1,8						
	24	1520	<b>61,12</b>	35646	2,0						
	29	1248	<b>50,13</b>	37240	2,4						
	33	1103	<b>44,27</b>	38051	2,7						
	37	982	<b>39,35</b>	39156	3,0						
	43	854	<b>33,86</b>	39349	3,5	<b>DR572-3E112M/4D</b>	8,05	177	116	IE3	
	51	729	<b>28,87</b>	40365	4,0						
	21	1751	<b>70,59</b>	14702	0,9	<b>DR473-3E112M/4D</b>	8,05	132	110	IE3	
	24	1536	<b>61,85</b>	18463	0,9						
	27	1351	<b>54,35</b>	20737	1,0						
	31	1179	<b>47,37</b>	22775	1,1						
	35	1034	<b>41,50</b>	24299	1,2						
	43	856	<b>34,28</b>	25898	1,4						
	51	711	<b>28,45</b>	27101	1,6						
	59	619	<b>24,54</b>	25285	2,5	<b>DR472-3E112M/4D</b>	8,05	126	110	IE3	
	70	524	<b>20,74</b>	25860	3,0						
	76	483	<b>19,11</b>	25979	3,2						
	86	430	<b>17,01</b>	25208	3,6						
	45	800	<b>32,11</b>	13644	0,9	<b>DR373-3E112M/4D</b>	8,05	94	106	IE3	
	53	685	<b>27,53</b>	15376	1,0						
	62	588	<b>23,58</b>	16591	1,1						
	65	566	<b>22,46</b>	15164	1,4	<b>DR372-3E112M/4D</b>	8,05	88	106	IE3	
	73	507	<b>20,10</b>	15754	1,6						
	83	445	<b>17,65</b>	16309	1,8						
	99	373	<b>14,74</b>	16900	2,2						
	107	343	<b>13,60</b>	17131	2,4						
	124	297	<b>11,77</b>	16942	2,7						
	142	260	<b>10,25</b>	16368	2,9						
	163	228	<b>8,98</b>	15825	3,1						
	197	188	<b>7,42</b>	15055	3,4						
	218	169	<b>6,69</b>	14518	3,1						
	252	147	<b>5,79</b>	13979	3,4						
	289	128	<b>5,05</b>	13478	3,6						
	330	112	<b>4,42</b>	13007	3,9						
		78	472	<b>18,73</b>	11476	1,2	<b>DR282-3E112M/4D</b>	8,05	54	102	IE3
		88	419	<b>16,62</b>	12456	1,3					
104		355	<b>14,06</b>	13556	1,5						
121		304	<b>12,03</b>	14300	1,6						
141		263	<b>10,38</b>	14851	1,7						
155		239	<b>9,45</b>	15153	1,8						
178		207	<b>8,19</b>	15151	2,0						
206		180	<b>7,09</b>	14605	2,1						
220		169	<b>6,65</b>	14285	2,0						
255		146	<b>5,74</b>	13753	2,2						
280		133	<b>5,22</b>	13418	2,3						
323		115	<b>4,52</b>	12919	2,4						

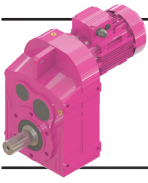

## D Serisi Motorlu Güç Devir Sayfaları

### D Series Geared Motors Performance Tables

#### D Serien Getriebemotoren Leistung und Drehzahlübersicht



Güç	IE3 Çıkış Devri	IE3 Çıkış Momenti	Çevrim Oranı	IE3 Güv. Rad. Yük Çıkış Per.O. Loads (Output)	IE3 Servis Faktörü	Tipi	Anma Akımı	Ağırlık	Ölçü Sayfası	Motor Verim Snf.
Power	Output Speeds	Output Torque	Ratio	Per.O. Loads (Output)	Service Factors	Type	Rated Current	Weight	Dim. Page	Motor Eff. Class
Leistung P <sub>g</sub> [kW] P <sub>g</sub> [HP]	Abtriebswelle Drehzahlen n <sub>2</sub> [r.p.m]	Abtriebswelle Drehmomente M <sub>2</sub> [Nm]	Übersetzung i	Zul.Querkräfte (Abtrieb) F <sub>qam</sub> [N]	Betriebsfaktor f <sub>s</sub>	Typ	Nennstrom [A]	Gewicht ~ [kg]	Maße Seite	Motor Effizienz-klasse
4,0 5,5	373	99	3,92	12429	2,6	DR282-3E112M/4D	8,05	54	102	IE3
	411	90	7,09	12145	3,4	DR282-3E112M/2C	7,28	50	102	IE3
	439	84	6,65	11892	3,3					
	508	73	5,74	11421	3,5					
	559	66	5,22	11125	3,7					
	645	57	4,52	10690	3,9					
	745	50	3,92	10266	4,0					
	91	403	16,00	12632	1,1	DR272-3E112M/4D	8,05	48	98	IE3
	103	357	14,14	13230	1,3					
	123	300	11,90	13113	1,5					
	144	256	10,11	12665	1,7					
	168	219	8,67	12233	1,8					
	213	173	6,84	11474	1,8					
	251	147	5,82	11038	2,0					
	293	126	4,98	10627	2,2					
336	110	8,67	10323	2,9	DR272-3E112M/2C	7,28	46	98	IE3	
426	87	6,84	9655	3,0						
501	74	5,82	9250	3,3						
585	63	4,98	8874	3,5						
5,5 7,5	2,6	18571	371,15	199011	1,0	DR974-3E132M/6D	11,55	828	142	IE3
	2,8	17336	523,19	202633	1,0	DR974-3E132S/4C	10,65	833	142	IE3
	3,5	13777	415,16	211954	1,3					
	3,9	12338	371,15	215398	1,5					
	4,4	11090	333,23	218216	1,6					
	5,1	9453	284,06	221678	1,9					
	5,8	8344	250,41	223881	2,2					
	6,6	7412	222,15	225649	2,4					
	7,4	6616	197,95	225999	2,7					
	4,4	11104	334,15	86126	1,2	DR874-3E132S/4C	10,65	544	136	IE3
	5,0	9740	293,46	92028	1,3					
	5,6	8617	259,15	96551	1,5					
	6,5	7514	225,61	100247	1,7					
	7,6	6545	128,20	103371	2,0	DR873-3E132M/6D	11,55	530	134	IE3
	8,4	5880	115,03	105394	2,2					
	9,6	5160	101,03	107474	2,5					
	11	4499	87,95	109257	2,9					
	11	4365	128,20	109629	3,0	DR873-3E132S/4C	10,65	531	134	IE3
	13	3921	115,03	110765	3,3					
	14	3441	101,03	111948	3,8					
	5,1	9687	190,20	40559	0,8	DR773-3E132M/6D	11,55	327	128	IE3
	6,1	8062	158,23	55041	1,0					
	6,6	7531	222,16	58725	1,1	DR773-3E132S/4C	10,65	347	128	IE3
	7,7	6457	190,20	65096	1,2					
9,2	5375	158,23	70674	1,5						

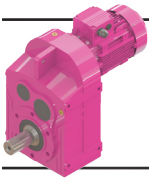

# D Serisi Motorlu Güç Devir Sayfaları

## D Series Geared Motors Performance Tables

### D Serien Getriebemotoren Leistung und Drehzahlübersicht



Güç	IE3 Çıkış Devri	IE3 Çıkış Momenti	Çevrim Oranı	IE3 Güv. Rad. Yük Çıkış Per.O. Loads (Output)	IE3 Servis Faktörü	Tipi	Anma Akımı	Ağırlık	Ölçü Sayfası	Motor Verim Snf.					
Power	Output Speeds	Output Torque	Ratio	Per.O. Loads (Output)	Service Factors	Type	Rated Current	Weight	Dim. Page	Motor Eff. Class					
Leistung P <sub>g</sub> [kW] P <sub>g</sub> [HP]	Abtriebswelle Drehzahlen n <sub>2</sub> [r.p.m]	Abtriebswelle Drehmomente M <sub>2</sub> [Nm]	Übersetzung i	Zul.Querkräfte (Abtrieb) F <sub>qam</sub> [N]	Betriebsfaktor f <sub>s</sub>	Typ	Nennstrom [A]	Gewicht ~ [kg]	Maße Seite	Motor Effizienz-klasse					
5,5 7,5	10	4813	<b>141,55</b>	73313	1,7	<b>DR773-3E132S/4C</b>	10,65	347	128	IE3					
	12	4159	<b>122,41</b>	76114	1,9										
	14	3607	<b>105,99</b>	78129	2,2										
	16	3159	<b>92,70</b>	79752	2,5										
	18	2788	<b>81,72</b>	81023	2,9										
	20	2476	<b>72,50</b>	82044	3,2										
	10	4749	<b>139,76</b>	23996	0,9						<b>DR673-3E132S/4C</b>	10,65	257	122	IE3
	12	4236	<b>124,53</b>	30119	1,0										
	14	3606	<b>106,08</b>	35903	1,2										
	16	3105	<b>91,19</b>	39572	1,4										
18	2698	<b>79,14</b>	42224	1,6											
21	2362	<b>69,18</b>	44240	1,8											
24	2079	<b>60,82</b>	45753	2,1											
25	2027	<b>59,34</b>	46036	2,1											
29	1746	<b>51,01</b>	47360	2,5											
33	1517	<b>44,27</b>	48408	2,8											
38	1328	<b>38,70</b>	49229	3,2											
43	1169	<b>34,02</b>	49888	3,7											
14	3518	<b>103,39</b>	12812	0,9	<b>DR573-3E132S/4C</b>	10,65	204	116	IE3						
16	3111	<b>91,30</b>	20634	1,0											
18	2768	<b>81,15</b>	25032	1,1											
21	2345	<b>68,64</b>	29293	1,3											
24	2090	<b>61,12</b>	31495	1,4											
29	1716	<b>50,13</b>	34309	1,7											
33	1517	<b>44,27</b>	35664	2,0											
37	1350	<b>39,35</b>	37191	2,2											
44	1144	<b>33,28</b>	39159	2,4											
51	1002	<b>28,87</b>	38609	3,0						<b>DR572-3E132S/4C</b>	10,65	197	116	IE3	
61	834	<b>24,02</b>	39459	3,6											
68	744	<b>21,40</b>	40014	4,0											
80	633	<b>18,23</b>	41802	4,0											
31	1621	<b>47,37</b>	18519	0,8	<b>DR473-3E132S/4C</b>	10,65	152	110	IE3						
35	1422	<b>41,50</b>	21196	0,9											
43	1177	<b>34,28</b>	23827	1,0											
51	978	<b>28,45</b>	25684	1,2											
59	852	<b>24,54</b>	23708	1,8	<b>DR472-3E132S/4C</b>	10,65	146	110	IE3						
70	721	<b>20,74</b>	24642	2,1											
76	664	<b>19,11</b>	25018	2,3											
86	592	<b>17,01</b>	24671	2,6											
97	523	<b>15,02</b>	23926	3,0											
109	465	<b>13,35</b>	23227	3,3											
118	431	<b>12,40</b>	22793	3,6											
139	365	<b>10,48</b>	21821	4,0											
164	311	<b>8,93</b>	20915	4,0											
194	263	<b>7,54</b>	19872	4,0											
218	234	<b>6,71</b>	19256	4,0											
234	217	<b>6,23</b>	18877	4,0											
277	184	<b>5,26</b>	18032	4,0											
326	157	<b>4,48</b>	17252	4,0											
390	130	<b>7,54</b>	16406	4,0	<b>DR472-3E132S/2B</b>	9,90	137	110	IE3						
439	116	<b>6,71</b>	15872	4,0											
473	107	<b>6,23</b>	15545	4,0											
560	91	<b>5,26</b>	14821	4,0											
657	77	<b>4,48</b>	14156	4,0											

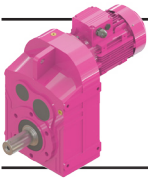

# D Serisi Motorlu Güç Devir Sayfaları

## D Series Geared Motors Performance Tables

### D Serien Getriebemotoren Leistung und Drehzahlübersicht

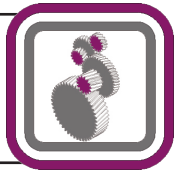

Güç	IE3 Çıkış Devri	IE3 Çıkış Momenti	Çevrim Oranı	IE3 Güv. Rad. Yük Çıkış Per.O. Loads (Output)	IE3 Servis Faktörü	Tipi	Anma Akımı	Ağırlık	Ölçü Sayfası	Motor Verim Snf.
Power	Output Speeds	Output Torque	Ratio	Per.O. Loads (Output)	Service Factors	Type	Rated Current	Weight	Dim. Page	Motor Eff. Class
Leistung P <sub>g</sub> [kW] P <sub>g</sub> [HP]	Abtriebswelle Drehzahlen n <sub>2</sub> [r.p.m]	Abtriebswelle Drehmomente M <sub>2</sub> [Nm]	Übersetzung i	Zul.Querkräfte (Abtrieb) F <sub>qam</sub> [N]	Betriebsfaktor f <sub>s</sub>	Typ	Nennstrom [A]	Gewicht ~ [kg]	Maße Seite	Motor Effizienz-klasse
5,5 7,5	83	612	17,65	14646	1,3	DR372-3E132S/4C	10,65	114	106	IE3
	99	512	14,74	15682	1,6					
	107	472	13,60	16049	1,7					
	124	409	11,77	16463	1,9					
	142	357	10,25	15952	2,1					
	163	313	8,98	15462	2,2					
	197	259	7,42	14757	2,5					
	218	233	6,69	14199	2,3					
	252	202	5,79	13704	2,5					
	289	176	5,05	13239	2,6					
	330	155	4,42	12798	2,8					
	400	128	3,65	12175	3,1					
440 508 583 666 806	115	115	6,69	11868	3,7	DR372-3E132S/2B	9,90	105	106	IE3
	100	100	5,79	11417	4,0					
	87	87	5,05	10998	4,0					
	76	76	4,42	10607	4,0					
	63	63	3,65	10059	4,0					
	63	63	3,65	10059	4,0					
104 121 141 155 178 206 220 255 280 323 373	489	489	14,06	12123	1,1	DR282-3E132S/4C	10,65	74	102	IE3
	419	419	12,03	13280	1,2					
	362	362	10,38	14091	1,3					
	329	329	9,45	14509	1,3					
	285	285	8,19	14758	1,4					
	247	247	7,09	14266	1,5					
	232	232	6,65	13937	1,5					
	200	200	5,74	13454	1,6					
	182	182	5,22	13146	1,6					
	158	158	4,52	12684	1,8					
	137	137	3,92	12226	1,9					
	137	137	3,92	12226	1,9					
415 443 513 564 651 752	122	122	7,09	11945	2,5	DR282-3E132S/2B	9,90	65	102	IE3
	115	115	6,65	11689	2,4					
	99	99	5,74	11242	2,6					
	90	90	5,22	10961	2,7					
	78	78	4,52	10544	2,9					
	68	68	3,92	10137	3,1					
7,5 10	3,5	18723	415,16	198352	1,0	DR974-3E132M/4D	14,40	832	142	IE3
	3,9	16768	371,15	204044	1,1					
	4,4	15071	333,23	208956	1,2					
	5,1	13330	191,74	213157	1,4					
	5,7	11902	171,00	216210	1,5					
	6,3	10721	153,87	218856	1,7					
	7,1	9484	136,23	221480	1,9					
	8,1	8307	119,15	216491	2,2					
	9,2	7353	105,33	209704	2,4					
	10	6563	93,91	203492	2,7					
	12	5899	84,31	197762	3,1					
	13	5030	71,87	189465	3,6					
5,0 5,7 6,5	13237	13237	293,46	75425	1,0	DR874-3E132M/4D	14,40	541	136	IE3
	11710	11710	259,15	83251	1,1					
	10211	10211	225,61	90070	1,3					
7,6 8,4 9,6	8928	8928	128,20	95338	1,5	DR873-3E160M/6	15,00	569	134	IE3
	8020	8020	115,03	98632	1,6					
	7038	7038	101,03	101926	1,8					

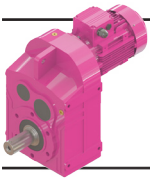

# D Serisi Motorlu Güç Devir Sayfaları

## D Series Geared Motors Performance Tables

### D Serien Getriebemotoren Leistung und Drehzahlübersicht

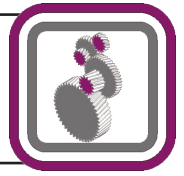

Güç	IE3 Çıkış Devri	IE3 Çıkış Momenti	Çevrim Oranı	IE3 Güv. Rad. Yük Çıkış Per.O. Loads (Output)	IE3 Servis Faktörü	Tipi	Anma Akımı	Ağırlık	Ölçü Sayfası	Motor Verim Snf.
Power	Output Speeds	Output Torque	Ratio	Per.O. Loads (Output)	Service Factors	Type	Rated Current	Weight	Dim. Page	Motor Eff. Class
Leistung P <sub>g</sub> [kW] P <sub>g</sub> [HP]	Abtriebswelle Drehzahlen n <sub>2</sub> [r.p.m]	Abtriebswelle Drehmomente M <sub>2</sub> [Nm]	Übersetzung i	Zul.Querkräfte (Abtrieb) F <sub>qam</sub> [N]	Betriebsfaktor f <sub>s</sub>	Typ	Nennstrom [A]	Gewicht ~ [kg]	Maße Seite	Motor Effizienz-klasse
7,5 10	11	5934	<b>128,20</b>	105268	2,2	<b>DR873-3E132M/4D</b>	14,40	533	134	IE3
	13	5330	<b>115,03</b>	107010	2,4					
	15	4678	<b>101,03</b>	108802	2,8					
	17	4079	<b>87,95</b>	110365	3,2					
	19	3593	<b>77,36</b>	111578	3,6					
7,7 9,3 10 12 14 16 18 20	7,7	8778	<b>190,20</b>	49412	0,9	<b>DR773-3E132M/4D</b>	14,40	353	128	IE3
	9,3	7306	<b>158,23</b>	60185	1,1					
	10	6543	<b>141,55</b>	64613	1,2					
	12	5654	<b>122,41</b>	69316	1,4					
	14	4903	<b>105,99</b>	72842	1,6					
	16	4294	<b>92,70</b>	75467	1,9					
	18	3790	<b>81,72</b>	77436	2,1					
	20	3366	<b>72,50</b>	79012	2,4					
23 26 29 30 35	23	2938	<b>41,85</b>	80447	2,7	<b>DR773-3E160M/6D</b>	15,00	406	128	IE3
	26	2609	<b>37,12</b>	81553	3,1					
	29	2329	<b>33,10</b>	81723	3,4					
	30	2244	<b>31,92</b>	80959	3,6					
	35	1947	<b>27,65</b>	77981	4,0					
14 16 19 21 24 25 29 33 38 43	14	4902	<b>106,08</b>	21751	0,9	<b>DR673-3E132M/4D</b>	14,40	263	122	IE3
	16	4221	<b>91,19</b>	30278	1,0					
	19	3668	<b>79,14</b>	35393	1,2					
	21	3211	<b>69,18</b>	38825	1,3					
	24	2826	<b>60,82</b>	41425	1,5					
	25	2756	<b>59,34</b>	41865	1,6					
	29	2373	<b>51,01</b>	44128	1,8					
	33	2063	<b>44,27</b>	45805	2,1					
	38	1806	<b>38,70</b>	47074	2,4					
	43	1590	<b>34,02</b>	48083	2,7					
56 63	56	1233	<b>26,11</b>	49626	3,5	<b>DR672-3E132M/4D</b>	14,40	253	122	IE3
	63	1104	<b>23,36</b>	50149	3,9					
21 24 29 33 37 44	21	3188	<b>68,64</b>	19385	0,9	<b>DR573-3E132M/4D</b>	14,40	210	116	IE3
	24	2842	<b>61,12</b>	24157	1,1					
	29	2333	<b>50,13</b>	29405	1,3					
	33	2063	<b>44,27</b>	31718	1,5					
	37	1836	<b>39,35</b>	34098	1,6					
	44	1555	<b>33,28</b>	36956	1,8					
51 61 68 80 93 108	51	1363	<b>28,87</b>	36623	2,2	<b>DR572-3E132M/4D</b>	14,40	203	116	IE3
	61	1134	<b>24,02</b>	37901	2,6					
	68	1012	<b>21,40</b>	38560	3,0					
	80	861	<b>18,23</b>	39327	3,5					
	93	741	<b>15,67</b>	39562	4,0					
	108	644	<b>13,60</b>	38083	4,0					
51	1330	<b>28,45</b>	23277	0,8	<b>DR473-3E132M/4D</b>	14,40	158	110	IE3	
60 71 77 86 98 110	60	1158	<b>24,54</b>	21194	1,3	<b>DR472-3E132M/4D</b>	14,40	148	110	IE3
	71	980	<b>20,74</b>	22734	1,6					
	77	903	<b>19,11</b>	23345	1,7					
	86	804	<b>17,01</b>	23926	1,9					
	98	711	<b>15,02</b>	23269	2,2					
	110	633	<b>13,35</b>	22643	2,4					

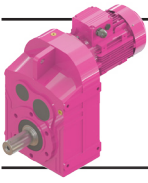

## D Serisi Motorlu Güç Devir Sayfaları

### D Series Geared Motors Performance Tables

#### D Serien Getriebemotoren Leistung und Drehzahlübersicht



Güç	IE3 Çıkış Devri	IE3 Çıkış Momenti	Çevrim Oranı	IE3 Güv. Rad. Yük Çıkış Per. O. Loads (Output)	IE3 Servis Faktörü	Tipi	Anma Akımı	Ağırlık	Ölçü Sayfası	Motor Verim Snf.					
Power	Output Speeds	Output Torque	Ratio	Per. O. Loads (Output)	Service Factors	Type	Rated Current	Weight	Dim. Page	Motor Eff. Class					
Leistung P <sub>g</sub> [kW] P <sub>g</sub> [HP]	Abtriebswelle Drehzahlen n <sub>2</sub> [r.p.m]	Abtriebswelle Drehmomente M <sub>2</sub> [Nm]	Übersetzung i	Zul. Querkräfte (Abtrieb) F <sub>qam</sub> [N]	Betriebsfaktor f <sub>s</sub>	Typ	Nennstrom [A]	Gewicht ~ [kg]	Maße Seite	Motor Effizienz-klasse					
7,5 10	118	587	12,40	22251	2,6	DR472-3E132M/4D	14,40	148	110	IE3					
	140	496	10,48	21361	3,1										
	164	423	8,93	20523	3,4										
	194	358	7,54	19493	3,3										
	218	318	6,71	18919	3,5										
	235	295	6,23	18563	3,6										
	278	250	5,26	17766	4,0										
	327	213	4,48	17024	4,0										
	390	178	7,54	16229	4,0						DR472-3E132S/2C	13,20	143	110	IE3
	439	158	6,71	15715	4,0										
473	147	6,23	15399	4,0											
560	124	5,26	14698	4,0											
657	106	4,48	14052	4,0											
83	833	17,65	11769	1,0	DR372-3E132M/4D	14,40	120	106	IE3						
	99	697	14,74	13652						1,2					
	108	642	13,60	14312						1,3					
	125	556	11,77	15496						1,4					
	143	485	10,25	15378						1,5					
	163	426	8,98	14959						1,6					
	197	352	7,42	14342						1,8					
	219	317	6,69	13757						1,7					
	253	275	5,79	13322						1,8					
	290	240	5,05	12906						1,9					
	331	210	4,42	12507						2,1					
	401	174	3,65	11933						2,2					
	440	158	6,69	11658						2,7	DR372-3E132S/2C	13,20	112	106	IE3
		508	137	5,79						11236					
583		119	5,05	10841	3,2										
666		104	4,42	10470	3,4										
806		86	3,65	9946	3,7										
122	569	12,03	11516	0,9	DR282-3E132M/4D	14,40	82	102	IE3						
	141	492	10,38	12805						0,9					
	155	448	9,45	13469						1,0					
	179	388	8,19	14216						1,1					
	207	336	7,09	13798						1,1					
	220	315	6,65	13456						1,1					
	255	272	5,74	13040						1,2					
	281	248	5,22	12769						1,2					
	324	215	4,52	12358						1,3					
	374	186	3,92	11944						1,4					
	415	167	7,09	11722						1,9	DR282-3E132S/2C	13,20	72	102	IE3
443		157	6,65	11460	1,8										
513		136	5,74	11045	1,9										
564		123	5,22	10782	2,0										
651		107	4,52	10390	2,1										
752		93	3,92	10003	2,3										
11 15	5,1	19562	191,74	195964	0,9	DR973-3E160L/6D	21,50	865	140	IE3					
	5,7	17467	171,00	201979	1,0										
	6,3	15733	153,87	206831	1,1										
	7,1	13918	136,23	211539	1,3										
	7,7	12950	191,74	213002	1,4						DR973-3E160M/4C	21,00	846	140	IE3
8,6	11564	171,00	207413	1,6											

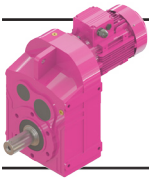

## D Serisi Motorlu Güç Devir Sayfaları

### D Series Geared Motors Performance Tables

#### D Serien Getriebemotoren Leistung und Drehzahlübersicht

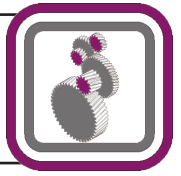

Güç	IE3 Çıkış Devri	IE3 Çıkış Momenti	Çevrim Oranı	IE3 Güv. Rad. Yük Çıkış	IE3 Servis Faktörü	Tipi	Anma Akımı	Ağırlık	Ölçü Sayfası	Motor Verim Snf.
Power	Output Speeds	Output Torque	Ratio	Per.O. Loads (Output)	Service Factors	Type	Rated Current	Weight	Dim. Page	Motor Eff. Class
Leistung P <sub>g</sub> [kW] P <sub>g</sub> [HP]	Abtriebswelle Drehzahlen n <sub>2</sub> [r.p.m]	Abtriebswelle Drehmomente M <sub>2</sub> [Nm]	Übersetzung i	Zul.Querkräfte (Abtrieb) F <sub>qam</sub> [N]	Betriebsfaktor f <sub>s</sub>	Typ	Nennstrom [A]	Gewicht ~ [kg]	Maße Seite	Motor Effizienz- klasse
11 15	9,6	10417	<b>153,87</b>	202265	1,7	<b>DR973-3E160M/4C</b>	21,00	846	140	IE3
	12	8073	<b>119,15</b>	189920	2,2					
	14	7146	<b>105,33</b>	184068	2,5					
	16	6379	<b>93,91</b>	178699	2,8					
	17	5733	<b>84,31</b>	173736	3,1					
	20	4889	<b>71,87</b>	166537	3,7					
	7,6	13102	<b>128,20</b>	76189	1,0	<b>DR873-3E160L/6D</b>	21,50	568	134	IE3
	8,4	11769	<b>115,03</b>	83159	1,1					
	9,6	10328	<b>101,03</b>	89728	1,3					
	11	8675	<b>128,20</b>	96275	1,5	<b>DR873-3E160M/4C</b>	21,00	549	134	IE3
	13	7793	<b>115,03</b>	99413	1,7					
	15	6839	<b>101,03</b>	102535	1,9					
	17	5964	<b>87,95</b>	105238	2,2					
	19	5253	<b>77,36</b>	107277	2,5					
	21	4665	<b>68,62</b>	108878	2,8					
	24	4171	<b>61,27</b>	110166	3,1					
	27	3749	<b>55,01</b>	111226	3,5					
	28	3537	<b>51,94</b>	111744	3,7					
	10	9566	<b>141,55</b>	42043	0,8					
	12	8267	<b>122,41</b>	53529	1,0					
	14	7169	<b>105,99</b>	61044	1,1					
	16	6279	<b>92,70</b>	66194	1,3					
	18	5542	<b>81,72</b>	69958	1,4					
	20	4922	<b>72,50</b>	72832	1,6					
	23	4393	<b>64,64</b>	75095	1,8					
	24	4233	<b>62,33</b>	75673	1,9					
	27	3672	<b>53,99</b>	78025	2,2					
	31	3200	<b>46,99</b>	78160	2,5					
	35	2856	<b>41,85</b>	76007	2,8					
	40	2537	<b>37,12</b>	73800	3,2					
	44	2265	<b>33,10</b>	71706	3,5					
	46	2182	<b>31,92</b>	71048	3,7					
	21	4694	<b>69,18</b>	24752	0,9	<b>DR673-3E160M/4C</b>	21,00	296	122	IE3
	24	4132	<b>60,82</b>	31197	1,0					
	25	4030	<b>59,34</b>	32186	1,1					
	29	3470	<b>51,01</b>	36977	1,2					
	33	3016	<b>44,27</b>	40245	1,4					
	38	2640	<b>38,70</b>	42628	1,6					
	43	2324	<b>34,02</b>	44445	1,9					
	49	2055	<b>30,04</b>	45809	2,1					
	56	1803	<b>26,11</b>	47106	2,4	<b>DR672-3E160M/4C</b>	21,00	286	122	IE3
	63	1615	<b>23,36</b>	47994	2,7					
	73	1395	<b>20,20</b>	48964	3,1					
	84	1210	<b>17,49</b>	49740	3,6					
	29	3410	<b>50,13</b>	15331	0,9	<b>DR573-3E160M/4C</b>	21,00	246	116	IE3
	33	3016	<b>44,27</b>	21948	1,0					
	37	2684	<b>39,35</b>	26941	1,1					
	44	2274	<b>33,28</b>	32079	1,2					
	52	1943	<b>28,39</b>	35497	1,3					
	61	1659	<b>24,02</b>	34737	1,8	<b>DR572-3E160M/4C</b>	21,00	236	116	IE3
	69	1480	<b>21,40</b>	35901	2,0					
	81	1259	<b>18,23</b>	37194	2,4					
	94	1084	<b>15,67</b>	38196	2,8					

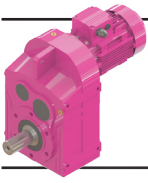

# D Serisi Motorlu Güç Devir Sayfaları

## D Series Geared Motors Performance Tables

### D Serien Getriebemotoren Leistung und Drehzahlübersicht



Güç	IE3 Çıkış Devri	IE3 Çıkış Momenti	Çevrim Oranı	IE3 Güv. Rad. Yük Çıkış Per.O. Loads (Output)	IE3 Servis Faktörü	Tipi	Anma Akımı	Ağırlık	Ölçü Sayfası	Motor Verim Snf.
Power	Output Speeds	Output Torque	Ratio	Per.O. Loads (Output)	Service Factors	Type	Rated Current	Weight	Dim. Page	Motor Eff. Class
Leistung P <sub>g</sub> [kW] P <sub>g</sub> [HP]	Abtriebswelle Drehzahlen n <sub>2</sub> [r.p.m]	Abtriebswelle Drehmomente M <sub>2</sub> [Nm]	Übersetzung i	Zul.Querkräfte (Abtrieb) F <sub>qam</sub> [N]	Betriebsfaktor f <sub>s</sub>	Typ	Nennstrom [A]	Gewicht ~ [kg]	Maße Seite	Motor Effizienz-klasse
11 15	108	942	13,60	37285	3,0	DR572-3E160M/4C	21,00	236	116	IE3
	124	824	11,89	36017	3,3					
	141	725	10,45	34824	3,5					
	170	599	8,65	32868	3,4					
	198	516	7,43	31579	3,7					
	228	448	6,45	30400	4,0					
	261	392	5,64	29310	4,0					
	297	345	4,96	28292	4,0					
	336	305	4,38	27334	4,0					
	71	1433	20,74	18374	1,1	DR472-3E160M/4C	21,00	191	110	IE3
	77	1320	19,11	19638	1,2					
	86	1176	17,01	21064	1,3					
	98	1040	15,02	22118	1,5					
	110	925	13,35	21624	1,7					
	119	858	12,40	21306	1,8					
	140	726	10,48	20565	2,1					
	165	619	8,93	19846	2,3					
	195	524	7,54	18836	2,3					
	219	466	6,71	18336	2,4					
	236	432	6,23	18022	2,5					
279	365	5,26	17309	2,7						
328	312	4,48	16634	2,9						
15 20	6,3	21348	153,87	190136	0,8	DR973-3E180L/6E	29,00	935	140	IE3
	7,2	18885	136,23	198061	1,0					
	7,7	17662	191,74	201861	1,0	DR973-3E160L/4E	29,00	861	140	IE3
	8,6	15771	171,00	200345	1,1					
	9,6	14207	153,87	195935	1,3					
	11	12569	136,23	190782	1,4					
	12	11010	119,15	185067	1,6					
	14	9746	105,33	179796	1,8					
	16	8700	93,91	174905	2,1					
	17	7820	84,31	170340	2,3					
	20	6668	71,87	163654	2,7					
	23	5886	63,36	158457	3,1					
	26	5228	56,21	153599	3,4					
	11	11832	128,20	83040	1,1	DR873-3E160L/4E	29,00	565	134	IE3
	13	10629	115,03	88576	1,2					
	15	9328	101,03	93920	1,4					
	17	8134	87,95	98325	1,6					
	19	7165	77,36	101590	1,8					
	21	6363	68,62	104135	2,0					
	24	5689	61,27	106096	2,3					
27	5113	55,01	107712	2,5						
28	4825	51,94	108496	2,7						
32	4224	45,41	110068	3,1						
37	3718	39,92	111333	3,5						
14	9778	105,99	39792	0,8	DR773-3E160L/4E	29,00	401	128	IE3	
16	8563	92,70	51192	0,9						
18	7559	81,72	58545	1,1						
20	6713	72,50	63899	1,2						
23	5992	64,64	67809	1,3						
24	5773	62,33	68915	1,4						
27	5008	53,99	72524	1,6						
31	4364	46,99	75276	1,8						
35	3896	41,85	73747	2,1						
40	3461	37,12	71803	2,3						

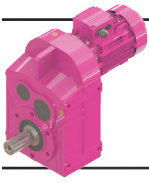

## D Serisi Motorlu Güç Devir Sayfaları

### D Series Geared Motors Performance Tables

#### D Serien Getriebemotoren Leistung und Drehzahlübersicht



Güç	IE3 Çıkış Devri	IE3 Çıkış Momenti	Çevrim Oranı	IE3 Güv. Rad. Yük Çıkış Per.O. Loads (Output)	IE3 Servis Faktörü	Tipi	Anma Akımı	Ağırlık	Ölçü Sayfası	Motor Verim Snf.						
Power	Output Speeds	Output Torque	Ratio	Per.O. Loads (Output)	Service Factors	Type	Rated Current	Weight	Dim. Page	Motor Eff. Class						
Leistung P <sub>g</sub> [kW] P <sub>g</sub> [HP]	Abtriebswelle Drehzahlen n <sub>2</sub> [r.p.m]	Abtriebswelle Drehmomente M <sub>2</sub> [Nm]	Übersetzung i	Zul.Querkräfte (Abtrieb) F <sub>qam</sub> [N]	Betriebsfaktor f <sub>s</sub>	Typ	Nennstrom [A]	Gewicht ~ [kg]	Maße Seite	Motor Effizienz-klasse						
15 20	44	3089	33,10	69933	2,6	DR773-3E160L/4E	29,00	401	128	IE3						
	46	2977	31,92	69340	2,7											
	53	2582	27,65	67002	3,1											
	61	2250	24,06	64756	3,6											
29	4733	51,01	24222	0,9	DR673-3E160L/4E	29,00	311	122	IE3							
	33	4114	44,27	31358						1,0						
	38	3601	38,70	36035						1,2						
	43	3170	34,02	39262						1,4						
	49	2802	30,04	41693						1,5						
	56	2460	26,11	43734						1,7	DR672-3E160L/4E	29,00	301	122	IE3	
63		2203	23,36	45142	2,0											
73		1903	20,20	46607	2,3											
84		1650	17,49	47858	2,6											
96		1445	15,30	48770	3,0											
109		1275	13,48	49694	3,3											
123		1132	11,96	51109	3,6											
138		1010	10,67	50313	3,8											
143		973	10,29	49831	3,9											
44		3102	33,28	23943	0,9	DR573-3E160L/4E	29,00	261	116	IE3						
		52	2650	28,39	30286											1,0
61	2263	24,02	30168	1,3	DR572-3E160L/4E	29,00	251	116	IE3							
	69	2018	21,40	32180						1,5						
	81	1718	18,23	34376						1,7						
	94	1479	15,67	35938						2,0						
	108	1285	13,60	36402						2,2						
	124	1124	11,89	35248						2,4						
	141	990	10,45	34151						2,6						
	170	818	8,65	32221						2,5						
	198	704	7,43	31024						2,7						
	228	611	6,45	29920						2,9						
	261	535	5,64	28892						3,1						
	297	471	4,96	27926						3,3						
	336	416	4,38	27011						3,5						
98	1418	15,02	18551	1,1	DR472-3E160L/4E	29,00	215	110	IE3							
	110	1262	13,35	20278						1,2						
	119	1170	12,40	20222						1,3						
	140	990	10,48	19657						1,6						
	165	844	8,93	19078						1,7						
	195	714	7,54	18089						1,7						
	219	635	6,71	17676						1,8						
	236	589	6,23	17411						1,8						
	279	499	5,26	16796						2,0						
	328	425	4,48	16201						2,2						
	18,5 25	8,6	19387	171,00						193925	0,9	DR973-3E180M/4C	34,50	901	140	IE3
		9,6	17464	153,87						190175	1,0					
11		15450	136,23	185696	1,2											
12		13534	119,15	180628	1,3											
14		11980	105,33	175876	1,5											
16		10694	93,91	171410	1,7											
17		9613	84,31	167201	1,9											
21		8197	71,87	160973	2,2											
23		7236	63,36	156087	2,5											
26		6427	56,21	151490	2,8											
34		4972	43,38	141753	3,6											

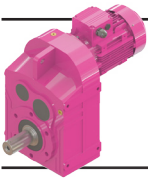

## D Serisi Motorlu Güç Devir Sayfaları

### D Series Geared Motors Performance Tables

#### D Serien Getriebemotoren Leistung und Drehzahlübersicht

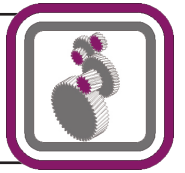

Güç Power Leistung P <sub>g</sub> [kW] P <sub>g</sub> [HP]	IE3	IE3	Çevrim Oranı Ratio Übersetzung i	IE3	IE3	Tipi Type Typ	Anma Akımı Rated Current Nennstrom [A]	Ağırlık Weight Gewicht ~ [kg]	Ölçü Sayfası Dim. Page Maße Seite	Motor Verim Snf. Motor Eff. Class Motor Effizienz-klasse
	Çıkış Devri Output Speeds	Çıkış Momenti Output Torque		Güv. Rad. Yük Çıkış Per.O. Loads (Output) Zul.Querkräfte (Abtrieb) F <sub>qam</sub> [N]	Servis Faktörü Service Factors Betriebsfaktor f <sub>s</sub>					
18,5 25	12	14544	<b>128,20</b>	67406	0,9	DR873-3E180M/4C	34,50	605	134	IE3
	13	13066	<b>115,03</b>	76391	1,0					
	15	11467	<b>101,03</b>	84605	1,1					
	17	9999	<b>87,95</b>	91103	1,3					
	19	8808	<b>77,36</b>	95782	1,5					
	21	7822	<b>68,62</b>	99313	1,7					
	24	6993	<b>61,27</b>	101922	1,9					
	27	6286	<b>55,01</b>	104319	2,1					
	28	5931	<b>51,94</b>	105467	2,2					
	32	5192	<b>45,41</b>	107447	2,5					
	37	4570	<b>39,92</b>	109130	2,8					
	48	3498	<b>30,50</b>	110047	3,7					
	18	9291	<b>81,72</b>	44784	0,9	DR773-3E180M/4C	34,50	441	128	IE3
	20	8252	<b>72,50</b>	53639	1,0					
	24	7097	<b>62,33</b>	61486	1,1					
	27	6156	<b>53,99</b>	66847	1,3					
	31	5365	<b>46,99</b>	70804	1,5					
	35	4789	<b>41,85</b>	71691	1,7					
	40	4254	<b>37,12</b>	69983	1,9					
	45	3798	<b>33,10</b>	68311	2,1					
	46	3659	<b>31,92</b>	67776	2,2					
	53	3174	<b>27,65</b>	65647	2,5					
	61	2766	<b>24,06</b>	63576	2,9					
		65	2638	<b>22,77</b>	62824					
74		2299	<b>19,82</b>	60757	3,5					
85		2025	<b>17,44</b>	58860	4,0					
	33	5057	<b>44,27</b>	19234	0,9	DR673-3E180M/4C	34,50	351	122	IE3
	38	4427	<b>38,70</b>	28011	1,0					
	43	3897	<b>34,02</b>	33413	1,1					
	49	3445	<b>30,04</b>	37171	1,2					
	56	3024	<b>26,11</b>	40194	1,4	DR672-3E180M/4C	34,50	341	122	IE3
	63	2708	<b>23,36</b>	42220	1,6					
	73	2339	<b>20,20</b>	44361	1,8					
	84	2029	<b>17,49</b>	46006	2,1					
	96	1776	<b>15,30</b>	47287	2,4					
	109	1568	<b>13,48</b>	48429	2,7					
	123	1392	<b>11,96</b>	50093	2,9					
	138	1242	<b>10,67</b>	49662	3,1					
	143	1197	<b>10,29</b>	49202	3,2					
	166	1038	<b>8,91</b>	47408	3,4					
	190	904	<b>7,75</b>	45708	3,7					
	198	868	<b>7,45</b>	45019	3,3					
	223	771	<b>6,61</b>	43618	3,5					
250	688	<b>5,89</b>	42302	3,7						
260	663	<b>5,68</b>	41890	3,8						
	61	2781	<b>24,02</b>	24887	1,1	DR572-3E180M/4C	34,50	291	116	IE3
	69	2481	<b>21,40</b>	28081	1,2					
	81	2112	<b>18,23</b>	31380	1,4					
	94	1818	<b>15,67</b>	33631	1,7					
	108	1580	<b>13,60</b>	35594	1,8					
	124	1382	<b>11,89</b>	34541	2,0					
	141	1216	<b>10,45</b>	33528	2,1					
	171	1005	<b>8,65</b>	31623	2,0					
	198	865	<b>7,43</b>	30509	2,2					
	229	752	<b>6,45</b>	29472	2,4					
	262	658	<b>5,64</b>	28498	2,5					

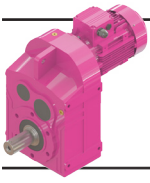

# D Serisi Motorlu Güç Devir Sayfaları

## D Series Geared Motors Performance Tables

### D Serien Getriebemotoren Leistung und Drehzahlübersicht



Güç	IE3 Çıkış Devri	IE3 Çıkış Momenti	Çevrim Oranı	IE3 Güv. Rad. Yük Çıkış Per.O. Loads (Output)	IE3 Servis Faktörü	Tipi	Anma Akımı	Ağırlık	Ölçü Sayfası	Motor Verim Snf.						
Power	Output Speeds	Output Torque	Ratio	Per.O. Loads (Output)	Service Factors	Type	Rated Current	Weight	Dim. Page	Motor Eff. Class						
Leistung P <sub>g</sub> [kW] P <sub>g</sub> [HP]	Abtriebswelle Drehzahlen n <sub>2</sub> [r.p.m]	Abtriebswelle Drehmomente M <sub>2</sub> [Nm]	Übersetzung i	Zul.Querkräfte (Abtrieb) F <sub>qam</sub> [N]	Betriebsfaktor f <sub>s</sub>	Typ	Nennstrom [A]	Gewicht ~ [kg]	Maße Seite	Motor Effizienz-klasse						
18,5 25	298 337	579 511	4,96 4,38	27578 26703	2,7 2,9	DR572-3E180M/4C	34,50	291	116	IE3						
22 30	11	18374	136,23	180681	1,0	DR973-3E180L/4D	42,50	904	140	IE3						
	12	16096	119,15	176275	1,1											
	14	14248	105,33	172053	1,3											
	16	12719	93,91	168021	1,4											
	17	11432	84,31	164173	1,6											
	21	9748	71,87	158409	1,8											
	23	8605	63,36	153837	2,1											
	26	7643	56,21	149503	2,4											
	34	5913	43,38	140230	3,0											
	39	5220	38,24	135800	3,4											
43	4637	33,93	131656	3,9												
22 30	15	13637	101,03	73103	1,0	DR873-3E180L/4D	42,50	608	134	IE3						
	17	11891	87,95	82552	1,1											
	19	10475	77,36	89089	1,2											
	21	9303	68,62	93895	1,4											
	24	8317	61,27	97578	1,6											
	27	7476	55,01	100487	1,7											
	28	7054	51,94	101711	1,8											
	32	6175	45,41	104682	2,1											
	37	5435	39,92	106765	2,4											
	48	4161	30,50	108822	3,1											
	55	3642	26,66	105180	3,6											
	63	3206	23,44	101746	4,0											
	22 30	24	8440	62,33	52195						0,9	DR773-3E180L/4D	42,50	444	128	IE3
		27	7322	53,99	60083						1,1					
31		6380	46,99	65641	1,3											
35		5696	41,85	69203	1,4											
40		5060	37,12	68194	1,6											
45		4517	33,10	66726	1,8											
46		4352	31,92	66250	1,8											
53		3775	27,65	64334	2,1											
61	3290	24,06	62440	2,4												
22 30	65	3137	22,77	61763	2,6	DR772-3E180L/4D	42,50	429	128	IE3						
	74	2735	19,82	59838	2,9											
	85	2409	17,44	58055	3,3											
	95	2139	15,46	56394	3,6											
	107	1911	13,81	54839	3,8											
22 30	43	4635	34,02	25522	0,9	DR673-3E180L/4D	42,50	354	122	IE3						
	49	4097	30,04	31539	1,0											
22 30	56	3596	26,11	35981	1,2	DR672-3E180L/4D	42,50	344	122	IE3						
	63	3220	23,36	38832	1,3											
	73	2782	20,20	41759	1,5											
	84	2413	17,49	43953	1,8											
	96	2113	15,30	45575	2,0											
	109	1865	13,48	47008	2,3											
	123	1656	11,96	49004	2,4											
	138	1478	10,67	49051	2,6											
	143	1423	10,29	48614	2,7											
	166	1234	8,91	46901	2,9											
	190	1075	7,75	45268	3,1											
	198	1033	7,45	44556	2,8											
	223	917	6,61	43208	3,0											

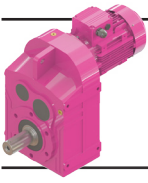

# D Serisi Motorlu Güç Devir Sayfaları

## D Series Geared Motors Performance Tables

### D Serien Getriebemotoren Leistung und Drehzahlübersicht

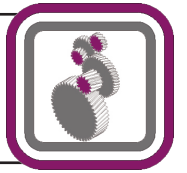

Güç	IE3 Çıkış Devri	IE3 Çıkış Momenti	Çevrim Oranı	IE3 Güv. Rad. Yük Çıkış Per. O. Loads (Output)	IE3 Servis Faktörü	Tipi	Anma Akımı	Ağırlık	Ölçü Sayfası	Motor Verim Snf.					
Power	Output Speeds	Output Torque	Ratio	Per. O. Loads (Output)	Service Factors	Type	Rated Current	Weight	Dim. Page	Motor Eff. Class					
Leistung P <sub>g</sub> [kW] P <sub>g</sub> [HP]	Abtriebswelle Drehzahlen n <sub>2</sub> [r.p.m]	Abtriebswelle Drehmomente M <sub>2</sub> [Nm]	Übersetzung i	Zul. Querkräfte (Abtrieb) F <sub>qam</sub> [N]	Betriebsfaktor f <sub>s</sub>	Typ	Nennstrom [A]	Gewicht ~ [kg]	Maße Seite	Motor Effizienz- klasse					
22 30	250	818	5,89	41937	3,2	DR672-3E180L/4D	42,50	344	122	IE3					
	260	788	5,68	41539	3,2										
	300	684	4,92	39988	3,5										
	344	595	4,28	38523	3,7										
	61	3308	24,02	17297	0,9	DR572-3E180L/4D	42,50	294	116	IE3					
	69	2951	21,40	22821	1,0										
	81	2511	18,23	27782	1,2										
	94	2162	15,67	30962	1,4										
	108	1879	13,60	34121	1,5										
	124	1644	11,89	33856	1,6										
	141	1447	10,45	32929	1,8										
	171	1195	8,65	31046	1,7										
	198	1029	7,43	30016	1,8										
	229	894	6,45	29046	2,0										
	262	783	5,64	28128	2,1										
	298	689	4,96	27254	2,3										
	337	608	4,38	26417	2,4										
	30 40	16	17345	93,91	160126						1,0	DR973-3G200L/4	55,00	930	140
		17	15590	84,31	157128	1,2									
		21	13294	71,87	152454	1,4									
23		11735	63,36	148619	1,5										
26		10424	56,21	144897	1,7										
29		9305	50,12	141287	1,9										
34		8064	43,38	136711	2,2										
39		7119	38,24	132711	2,5										
43		6323	33,93	128926	2,8										
57		4831	25,92	119680	3,7										
21		12687	68,62	78462	1,0	DR873-3G200L/4	55,00	634	134	IE3					
24		11342	61,27	85191	1,1										
27		10195	55,01	90282	1,3										
28		9619	51,94	92646	1,4										
32		8421	45,41	97201	1,5										
37		7413	39,92	100697	1,8										
42		6552	35,24	103433	2,0										
48		5674	30,50	105990	2,3										
55		4968	26,66	102716	2,6										
63		4373	23,44	99587	3,0										
83		3297	17,67	92088	3,3										
95		2886	15,45	89035	3,7										
109		2541	13,58	86150	4,0										
35		7768	41,85	57128	1,0						DR773-3G200L/4	55,00	470	128	IE3
40		6900	37,12	62675	1,2										
45		6160	33,10	63030	1,3										
46		5935	31,92	62694	1,3										
53		5149	27,65	61279	1,6										
61		4487	24,06	59800	1,8										
65		4278	22,77	59298	1,9	DR772-3G200L/4	55,00	455	128	IE3					
74		3730	19,82	57706	2,1										
85		3285	17,44	56190	2,4										
95		2917	15,46	54749	2,6										
107		2607	13,81	53376	2,8										
119		2343	12,40	52064	3,0										
126		2210	11,71	51365	3,1										
144		1934	10,23	49733	3,3										
164		1702	9,00	48181	3,6										
170		1645	8,70	47306	3,2										

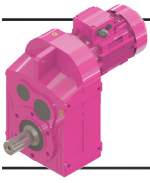

## D Serisi Motorlu Güç Devir Sayfaları

### D Series Geared Motors Performance Tables

#### D Serien Getriebemotoren Leistung und Drehzahlübersicht



Güç	IE3 Çıkış Devri	IE3 Çıkış Momenti	Çevrim Oranı	IE3 Güv. Rad. Yük Çıkış Per.O. Loads (Output)	IE3 Servis Faktörü	Tipi	Anma Akımı	Ağırlık	Ölçü Sayfası	Motor Verim Snf.	
Power	Output Speeds	Output Torque	Ratio	Per.O. Loads (Output)	Service Factors	Type	Rated Current	Weight	Dim. Page	Motor Eff. Class	
Leistung P <sub>g</sub> [kW] P <sub>g</sub> [HP]	Abtriebswelle Drehzahlen n <sub>2</sub> [r.p.m]	Abtriebswelle Drehmomente M <sub>2</sub> [Nm]	Übersetzung i	Zul.Querkräfte (Abtrieb) F <sub>qam</sub> [N]	Betriebsfaktor f <sub>s</sub>	Typ	Nennstrom [A]	Gewicht ~ [kg]	Maße Seite	Motor Effizienz-klasse	
30 40	190	1470	7,76	46012	3,4	DR772-3G200L/4	55,00	455	128	IE3	
	212	1321	6,97	44792	3,6						
	224	1246	6,58	44147	3,7						
	256	1091	5,75	42653	4,0						
	292	960	5,06	41246	4,0						
	330	848	4,47	39911	4,0						
	73	73	3795	20,20	34319	1,1	DR672-3G200L/4	55,00	370	122	IE3
		84	3290	17,49	38327	1,3					
		96	2881	15,30	41129	1,5					
		109	2543	13,48	43495	1,7					
		123	2258	11,96	46209	1,8					
		138	2015	10,67	47639	1,9					
		143	1941	10,29	47254	2,0					
		166	1684	8,91	45729	2,1					
		190	1467	7,75	44252	2,3					
		198	1409	7,45	43485	2,0					
		223	1251	6,61	42262	2,2					
		250	1117	5,89	41097	2,3					
		260	1076	5,68	40729	2,4					
		300	933	4,92	39289	2,5					
344		812	4,28	37917	2,7						
37 50	21	16397	71,87	147136	1,1	DR973-3G225S/4	67,00	1020	140	IE3	
	23	14474	63,36	143967	1,2						
	26	12857	56,21	140798	1,4						
	29	11477	50,12	137653	1,6						
	34	9946	43,38	133587	1,8						
	39	8780	38,24	129972	2,1						
	43	7799	33,93	126508	2,3						
	57	5959	25,92	117636	3,0						
	65	5261	22,85	114147	3,3						
	73	4673	20,27	110852	3,6						
	27	27	12575	55,01	79060	1,0	DR873-3G225S/4	67,00	723	134	IE3
		28	11865	51,94	82684	1,1					
		32	10387	45,41	89469	1,3					
		37	9143	39,92	94513	1,4					
		42	8082	35,24	98411	1,6					
		48	6999	30,50	101903	1,9					
		55	6127	26,66	100531	2,1					
		63	5394	23,44	97677	2,4					
		83	4067	17,67	90478	2,7					
		95	3560	15,45	87634	3,0					
105	105	3265	14,02	86316	3,4	DR872-3G225S/4	67,00	705	134	IE3	
	119	2881	12,36	83594	3,7						
	135	2558	10,97	81048	4,0						
	151	2283	9,78	78649	4,0						
45	45	7597	33,10	58284	1,1	DR773-3G225S/4	67,00	555	128	IE3	
	46	7320	31,92	59505	1,1						
	53	6351	27,65	58545	1,3						
	61	5534	24,06	57443	1,4						
	71	4800	20,87	54829	1,2						
	79	4285	18,61	53888	1,3						
	82	4128	17,95	53573	1,3						

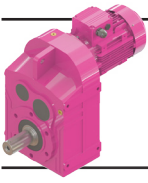

# D Serisi Motorlu Güç Devir Sayfaları

## D Series Geared Motors Performance Tables

### D Serien Getriebemotoren Leistung und Drehzahlübersicht

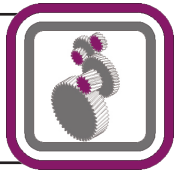

Güç	IE3 Çıkış Devri	IE3 Çıkış Momenti	Çevrim Oranı	IE3 Güv. Rad. Yük Çıkış Per.O. Loads (Output)	IE3 Servis Faktörü	Tipi	Anma Akımı	Ağırlık	Ölçü Sayfası	Motor Verim Snf.					
Power	Output Speeds	Output Torque	Ratio	Per.O. Loads (Output)	Service Factors	Type	Rated Current	Weight	Dim. Page	Motor Eff. Class					
Leistung P <sub>g</sub> [kW] P <sub>g</sub> [HP]	Abtriebswelle Drehzahlen n <sub>2</sub> [r.p.m]	Abtriebswelle Drehmomente M <sub>2</sub> [Nm]	Übersetzung i	Zul.Querkräfte (Abtrieb) F <sub>qam</sub> [N]	Betriebsfaktor f <sub>s</sub>	Typ	Nennstrom [A]	Gewicht ~ [kg]	Maße Seite	Motor Effizienz- klasse					
37 50	95	3598	15,46	53286	2,1	DR772-3G225S/4	67,00	548	128	IE3					
	107	3216	13,81	52076	2,3										
	119	2890	12,40	50903	2,4										
	126	2726	11,71	50272	2,5										
	144	2386	10,23	48782	2,7										
	164	2099	9,00	47349	2,9										
	170	2029	8,70	46387	2,6										
	190	1814	7,76	45195	2,8										
	212	1630	6,97	44061	2,9										
	224	1537	6,58	43458	3,0										
	256	1345	5,75	42053	3,2										
	292	1184	5,06	40720	3,4										
	330	1046	4,47	39449	3,6										
45 60	23	17605	63,36	138551	1,0	DR973-3G225M/4	80,00	1050	140	IE3					
	26	15638	56,21	136032	1,2										
	29	13959	50,12	133434	1,3										
	34	12097	43,38	129965	1,5										
	39	10680	38,24	126800	1,7										
	43	9487	33,93	123710	1,9										
	57	7248	25,92	115272	2,5										
	65	6399	22,85	112074	2,7										
	73	5684	20,27	109022	3,0										
	89	4713	16,64	104840	3,8						DR972-3G225M/4	80,00	1031	140	IE3
	32	12633	45,41	78748	1,0						DR873-3G225M/4	80,00	751	134	IE3
	37	11121	39,92	86217	1,2										
	42	9830	35,24	91795	1,3										
48	8512	30,50	96872	1,5											
55	7453	26,66	98003	1,7											
63	6560	23,44	95467	2,0											
83	4946	17,67	88617	2,2											
95	4331	15,45	86016	2,4											
109	3812	13,58	83508	2,7											
105	3971	14,02	85020	2,8	DR872-3G225M/4	80,00	735	134	IE3						
119	3504	12,36	82456	3,0											
135	3112	10,97	80041	3,3											
151	2777	9,78	77754	3,5											
169	2488	8,75	75576	3,7											
182	2307	8,12	73621	3,4											
206	2036	7,16	71268	3,7											
232	1808	6,35	69071	3,9											
260	1613	5,66	67004	4,0											
53	7724	27,65	55351	1,0						DR773-3G225M/4	80,00	586	128	IE3	
61	6732	24,06	54694	1,2											
71	5838	20,87	52130	1,0											
79	5212	18,61	51504	1,1											
82	5022	17,95	51281	1,1											
95	4376	15,46	51587	1,8	DR772-3G225M/4	80,00	578	128	IE3						
107	3911	13,81	50569	1,9											
119	3515	12,40	49558	2,0											
126	3316	11,71	49005	2,1											
144	2902	10,23	47682	2,2											
164	2554	9,00	46388	2,4											
170	2468	8,70	45324	2,1											

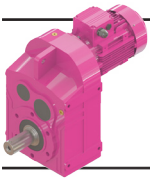

# D Serisi Motorlu Güç Devir Sayfaları

## D Series Geared Motors Performance Tables

### D Serien Getriebemotoren Leistung und Drehzahlübersicht



Güç	IE3 Çıkış Devri	IE3 Çıkış Momenti	Çevrim Oranı	IE3 Güv. Rad. Yük Çıkış Per.O. Loads (Output)	IE3 Servis Faktörü	Tipi	Anma Akımı	Ağırlık	Ölçü Sayfası	Motor Verim Snf.						
Power	Output Speeds	Output Torque	Ratio	Per.O. Loads (Output)	Service Factors	Type	Rated Current	Weight	Dim. Page	Motor Eff. Class						
Leistung P <sub>g</sub> [kW] P <sub>g</sub> [HP]	Abtriebswelle Drehzahlen n <sub>2</sub> [r.p.m]	Abtriebswelle Drehmomente M <sub>2</sub> [Nm]	Übersetzung i	Zul.Querkräfte (Abtrieb) F <sub>qam</sub> [N]	Betriebsfaktor f <sub>s</sub>	Typ	Nennstrom [A]	Gewicht ~ [kg]	Maße Seite	Motor Effizienz-klasse						
45 60	190	2206	7,76	44251	2,3	DR772-3G225M/4	80,00	578	128	IE3						
	212	1983	6,97	43217	2,4											
	224	1870	6,58	42663	2,5											
	256	1637	5,75	41361	2,7											
	292	1440	5,06	40115	2,8											
	330	1272	4,47	38916	3,0											
55 75	30	17004	50,12	128000	1,1	DR973-3G250M/4	96,00	1135	140	IE3						
	34	14736	43,38	125293	1,2											
	39	13009	38,24	122701	1,4											
	44	11556	33,93	120086	1,6											
	57	8829	25,92	112199	2,0											
	65	7795	22,85	109372	2,2											
	73	6924	20,27	106629	2,4											
	89	100	5742	16,64	103071	3,1	DR972-3G250M/4	96,00	1116	140	IE3					
		112	5100	14,77	100154	3,5										
		125	4560	13,19	97419	3,9										
		125	4100	11,85	94841	4,0										
		42	11974	35,24	82139	1,1						DR873-3G250M/4	96,00	836	134	IE3
		49	10369	30,50	89541	1,3										
	56	9078	26,66	94741	1,4											
	63	7992	23,44	92610	1,6											
	84	6025	17,67	86202	1,8											
	96	5275	15,45	83909	2,0											
	109	4644	13,58	81659	2,2											
75 97	106	4837	14,02	83320	2,3	DR872-3G250M/4	96,00	820	134	IE3						
	120	4269	12,36	80956	2,5											
	135	3791	10,97	78708	2,7											
	151	3383	9,78	76563	2,8											
	169	3031	8,75	74507	3,0											
	182	2811	8,12	72511	2,8											
	207	2481	7,16	70287	3,0											
	233	2203	6,35	68197	3,2											
	261	1965	5,66	66221	3,4											
	39	17681	38,24	114422	1,0	DR973-3G280S/4	133,00	1295	140	IE3						
		44	15706	33,93	112795						1,1					
		57	12000	25,92	106031						1,5					
		65	10595	22,85	103969						1,6					
		73	9411	20,27	101861						1,8					
		89	7804	16,64	99589						2,3					
	101	6932	14,77	97071	2,6	DR972-3G280S/4	133,00	1170	140	IE3						
		113	6198	13,19	94669						2,9					
		125	5573	11,85	92373						3,2					
149		4677	9,94	87788	3,2											
168		4154	8,82	85342	3,4											
188		3714	7,88	83043	3,6											
210		3339	7,08	80872	3,9											
56		12339	26,66	80292	1,1						DR873-3G280S/4	133,00	996	134	IE3	
		63	10862	23,44	86865											1,2
		84	8190	17,67	81356											1,3
	96	7170	15,45	79700	1,5											
	109	6312	13,58	77978	1,6											

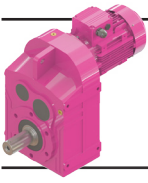

## D Serisi Motorlu Güç Devir Sayfaları

### D Series Geared Motors Performance Tables

#### D Serien Getriebemotoren Leistung und Drehzahlübersicht

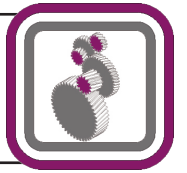

Güç	IE3 Çıkış Devri	IE3 Çıkış Momenti	Çevrim Oranı	IE3 Güv. Rad. Yük Çıkış Per.O. Loads (Output)	IE3 Servis Faktörü	Tipi	Anma Akımı	Ağırlık	Ölçü Sayfası	Motor Verim Snf.							
Power	Output Speeds	Output Torque	Ratio	Per.O. Loads (Output)	Service Factors	Type	Rated Current	Weight	Dim. Page	Motor Eff. Class							
Leistung P <sub>g</sub> [kW] P <sub>g</sub> [HP]	Abtriebswelle Drehzahlen n <sub>2</sub> [r.p.m]	Abtriebswelle Drehmomente M <sub>2</sub> [Nm]	Übersetzung i	Zul.Querkräfte (Abtrieb) F <sub>qam</sub> [N]	Betriebsfaktor f <sub>s</sub>	Typ	Nennstrom [A]	Gewicht ~ [kg]	Maße Seite	Motor Effizienz-klasse							
75 97	106	6575	14,02	79954	1,7	DR872-3G280S/4	133,00	967	134	IE3							
	120	5803	12,36	77998	1,8												
	135	5153	10,97	76090	2,0												
	152	4598	9,78	74232	2,1												
	170	4120	8,75	72422	2,2												
	183	3821	8,12	70338	2,1												
	207	3372	7,16	68373	2,2												
	234	2994	6,35	66500	2,4												
262	2672	5,66	64709	2,5													
90 117	57	14401	25,92	101336	1,2	DR973-3G280M/4	158,00	1355	140	IE3							
	65	12714	22,85	99874	1,4												
	73	11294	20,27	98262	1,5												
		89	9365	16,64	96996	1,9	DR972-3G280M/4	158,00	1230	140	IE3						
		101	8319	14,77	94785	2,2											
		113	7439	13,19	92638	2,4											
		125	6688	11,85	90558	2,7											
		149	5612	9,94	86096	2,7											
		168	4985	8,82	83848	2,8											
		188	4457	7,88	81715	3,0											
		210	4007	7,08	79684	3,2											
			96	8605	15,45	76513						1,2	DR873-3G280M/4	158,00	1056	134	IE3
			109	7575	13,58	75203						1,3					
		106	7891	14,02	77431	1,4	DR872-3G280M/4	158,00	1027	134	IE3						
		120	6964	12,36	75790	1,5											
		135	6184	10,97	74144	1,6											
		152	5518	9,78	72507	1,7											
		170	4944	8,75	70885	1,8											
		183	4585	8,12	68728	1,7											
		207	4047	7,16	66962	1,8											
234		3593	6,35	65255	2,0												
262		3206	5,66	63604	2,1												
110 150		57	17577	25,92	94903	1,0						DR973-3G315S/4	194,00	1551	140	IE3	
		65	15518	22,85	94271	1,1											
		73	13786	20,27	93342	1,2											
	89	11431	16,64	93460	1,6	DR972-3G315S/4	194,00	1426	140	IE3							
	101	10154	14,77	91668	1,8												
	113	9079	13,19	89869	2,0												
	125	8163	11,85	88082	2,2												
	150	6850	9,94	83786	2,2												
	169	6085	8,82	81809	2,3												
	189	5441	7,88	79900	2,5												
	210	4891	7,08	78059	2,6												
	132 180	65	18623	22,85	87944						0,9	DR973-3G315M/4a	230,00	1572	140	IE3	
		73	16543	20,27	87804						1,0						
	89	13718	16,64	89520	1,3	DR972-3G315M/4a	230,00	1447	140	IE3							
	101	12185	14,77	88203	1,5												
	113	10896	13,19	86799	1,7												
	125	9796	11,85	85343	1,8												
	150	8221	9,94	81230	1,8												
	169	7302	8,82	79558	1,9												

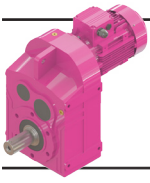

## D Serisi Motorlu Güç Devir Sayfaları

### D Series Geared Motors Performance Tables

#### D Serien Getriebemotoren Leistung und Drehzahlübersicht



Güç	IE3 Çıkış Devri	IE3 Çıkış Momenti	Çevrim Oranı	IE3 Güv. Rad. Yük Çıkış Per.O. Loads (Output)	IE3 Servis Faktörü	Tipi	Anma Akımı	Ağırlık	Ölçü Sayfası	Motor Verim Snf.
Power	Output Speeds	Output Torque	Ratio	Per.O. Loads (Output)	Service Factors	Type	Rated Current	Weight	Dim. Page	Motor Eff. Class
Leistung P <sub>g</sub> [kW] P <sub>g</sub> [HP]	Abtriebswelle Drehzahlen n <sub>2</sub> [r.p.m]	Abtriebswelle Drehmomente M <sub>2</sub> [Nm]	Übersetzung i	Zul.Querkräfte (Abtrieb) F <sub>qam</sub> [N]	Betriebsfaktor f <sub>s</sub>	Typ	Nennstrom [A]	Gewicht ~ [kg]	Maße Seite	Motor Effizienz- klasse
<b>132</b> 180	189 210	6529 5870	<b>7,88</b> <b>7,08</b>	77903 76276	2,1 2,2	<b>DR972-3G315M/4a</b>	230,00	1447	140	IE3
<b>160</b> 220	89 101 113 126 150 169 189 210	16617 14761 13199 11866 9959 8846 7910 7111	<b>16,64</b> <b>14,77</b> <b>13,19</b> <b>11,85</b> <b>9,94</b> <b>8,82</b> <b>7,88</b> <b>7,08</b>	84381 83692 82805 81785 77906 76634 75310 73962	1,1 1,2 1,4 1,5 1,5 1,6 1,7 1,8	<b>DR972-3G315M/4b</b>	275,00	1495	140	IE3

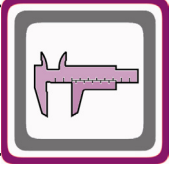
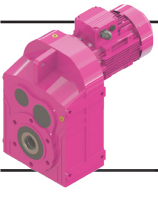

# Ölçü Tabloları

*The Table of  
Dimensions*

Abmessungs-  
tabellen

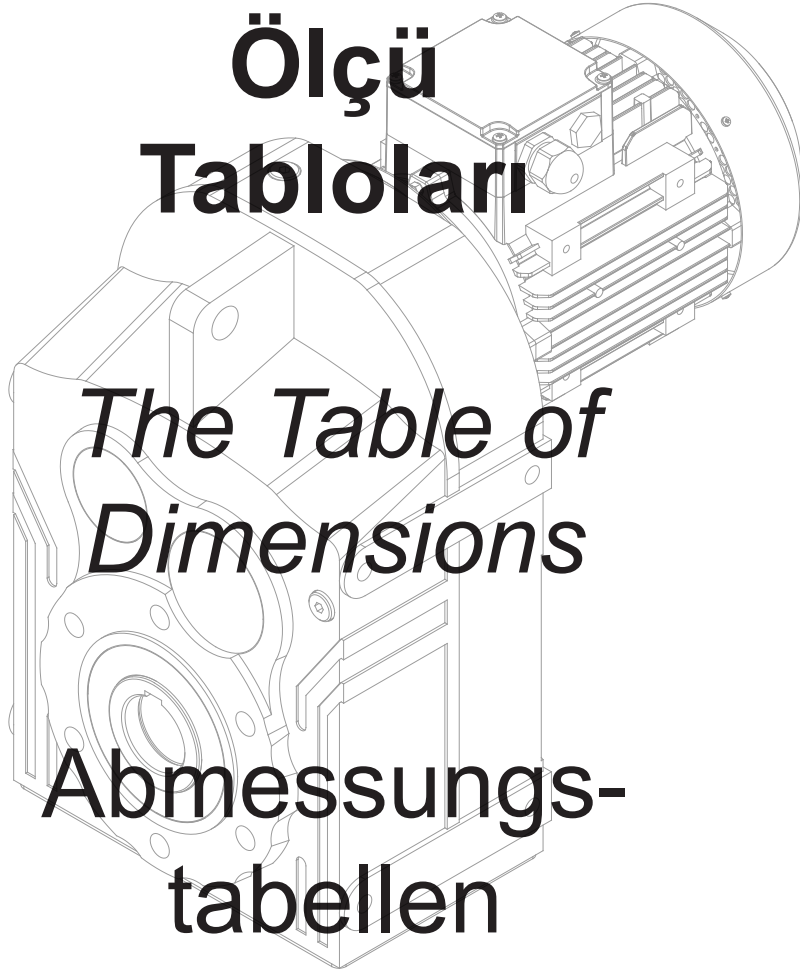

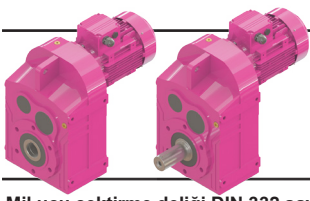

# Ölçü Sayfaları Dimension Pages Abmessungsseiten

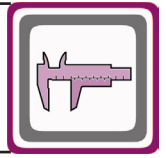

Mil ucu çektirme deliği DIN 332 sayfa 2 / Tapped center hole according to DIN 332, sheet 2 / Zentrierung mit Gewinde nach DIN 332, Blatt 2

DR072.00  
DR073.00

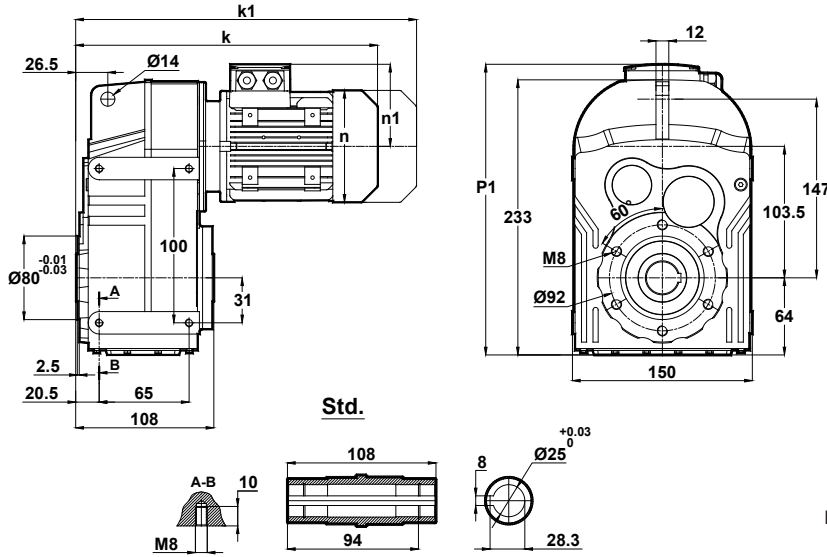

Std.

Klemens Pozisyonları  
Terminal Box Positions  
Klemmenkasten Positionen

	63	71	80	90S	90L	100L
k	298.5	328	362	401	401	449
k1	359.5	419	455	504.5	504.5	557.5
n	121	137	155	176	176	193
n1	97	112	121	132	132	147
p1	286	301	310	321	321	336

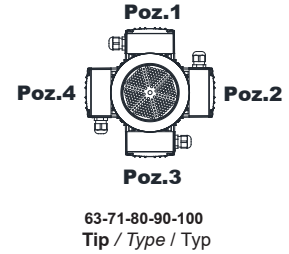

DR072.01  
DR073.01

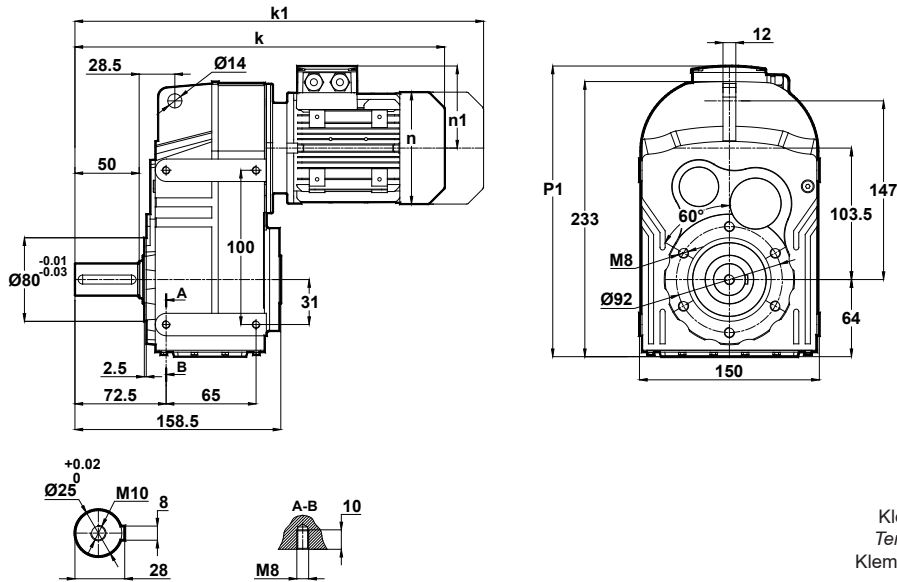

Klemens Pozisyonları  
Terminal Box Positions  
Klemmenkasten Positionen

	63	71	80	90S	90L	100L
k	350.5	380	414	453	453	501
k1	411.5	471	507	556.5	556.5	609.5
n	121	137	155	176	176	193
n1	97	112	121	132	132	147
p1	286	301	310	321	321	336

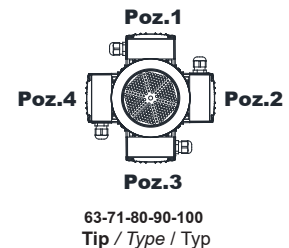

"k1" ölçüsü frenli redüktörlere aittir.  
Dimensions "k1" is for motors with brake.  
Maße "k1" ist für Bremsenmotoren.

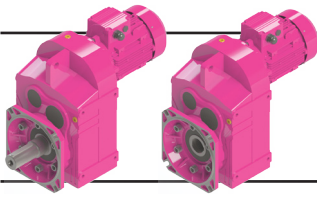

# Ölçü Sayfaları

## Dimension Pages

### Abmessungsseiten

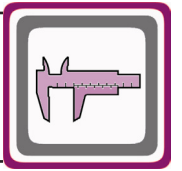

Mil ucu çektirme deliği DIN 332 sayfa 2 / Tapped center hole according to DIN 332, sheet 2 / Zentrierung mit Gewinde nach DIN 332, Blatt 2

DR072.02  
DR073.02

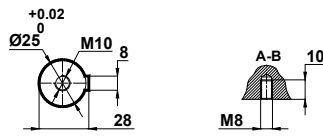
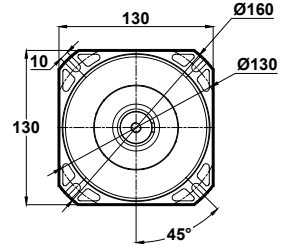
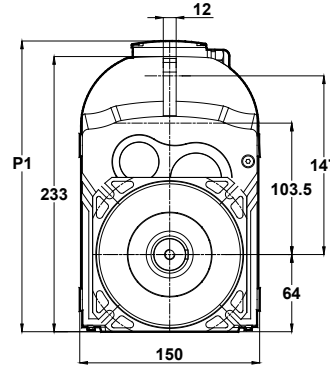
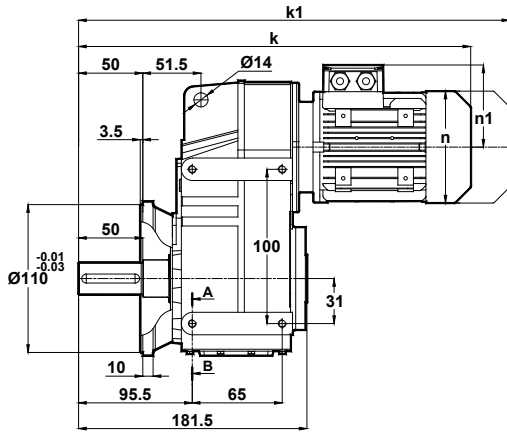

Klemens Pozisyonları  
Terminal Box Positions  
Klemmenkasten Positionen

Opsiyonel Flanş Ölçüleri  
Optional Flange Dimensions  
Auswählbare Flanschabmessungen

	63	71	80	90S	90L	100L
k	373.5	403	437	476	476	534
k1	434.5	494	530	579.5	579.5	632.5
n	121	137	155	176	176	193
n1	97	112	121	132	132	147
p1	286	301	310	321	321	336

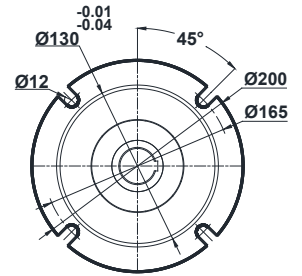
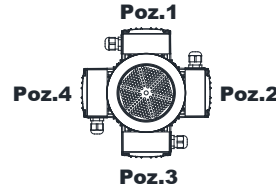

63-71-80-90-100  
Tip / Type / Typ

DR072.03  
DR073.03

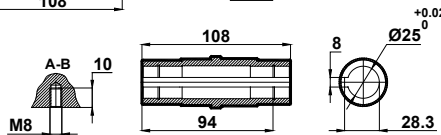
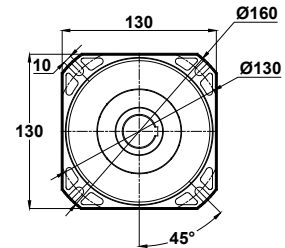
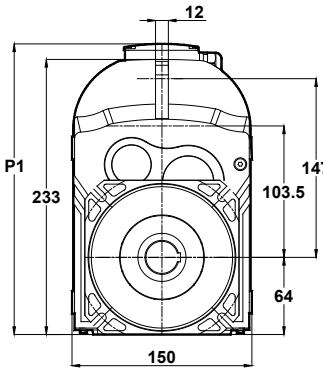
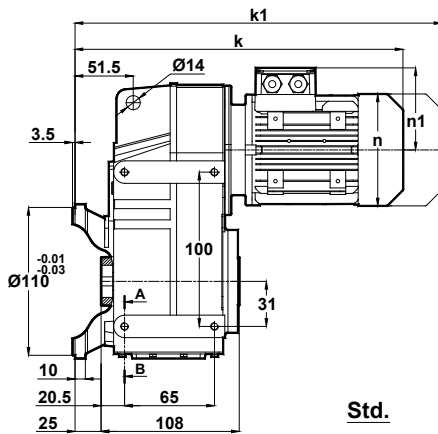

Klemens Pozisyonları  
Terminal Box Positions  
Klemmenkasten Positionen

Opsiyonel Flanş Ölçüleri  
Optional Flange Dimensions  
Auswählbare Flanschabmessungen

	63	71	80	90S	90L	100L
k	323.5	353	387	426	426	474
k1	384.5	444	480	529.5	529.5	582.5
n	121	137	155	176	176	193
n1	97	112	121	132	132	147
p1	286	301	310	321	321	336

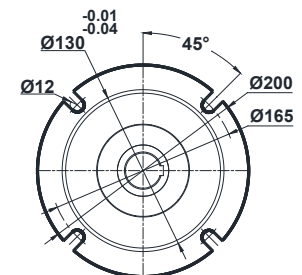
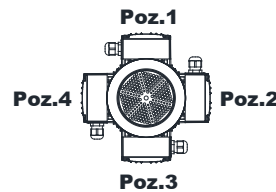

63-71-80-90-100  
Tip / Type / Typ

"k1" ölçüsü frenli redüktörlere aittir.  
Dimensions "k1" is for motors with brake.  
Maße "k1" ist für Bremsenmotoren.

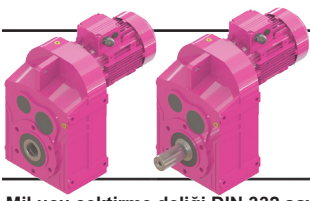

# Ölçü Sayfaları

## Dimension Pages

### Abmessungsseiten

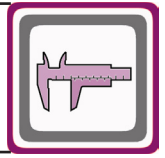

Mil ucu çektirme deliği DIN 332 sayfa 2 / Tapped center hole according to DIN 332, sheet 2 / Zentrierung mit Gewinde nach DIN 332, Blatt 2

DR172.00  
DR173.00

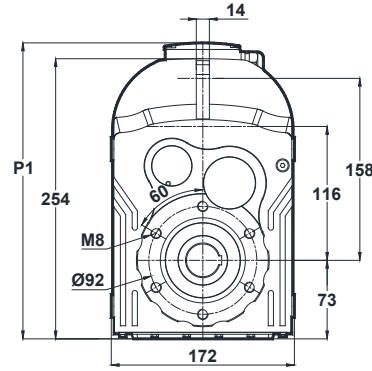
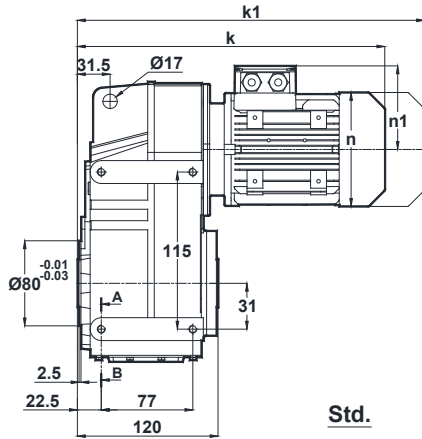

Std.

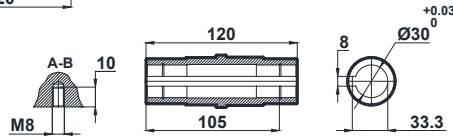

Klemens Pozisyonları  
Terminal Box Positions  
Klemmenkasten Positionen

	63	71	80	90S	90L	100L
k	308	337	371	410	410	458
k1	369	428	464	514.5	514.5	577.5
n	121	137	155	176	176	193
n1	97	112	121	132	132	147
p1	286	301	310	321	321	336

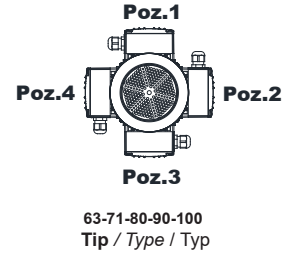

DR172.01  
DR173.01

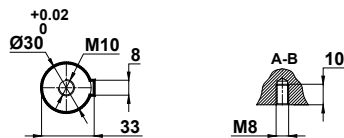
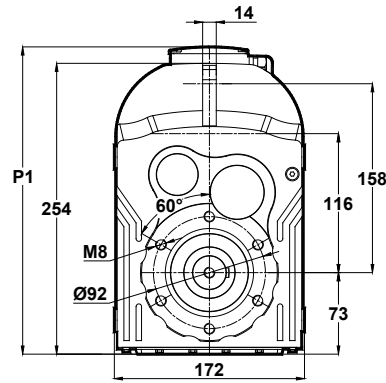
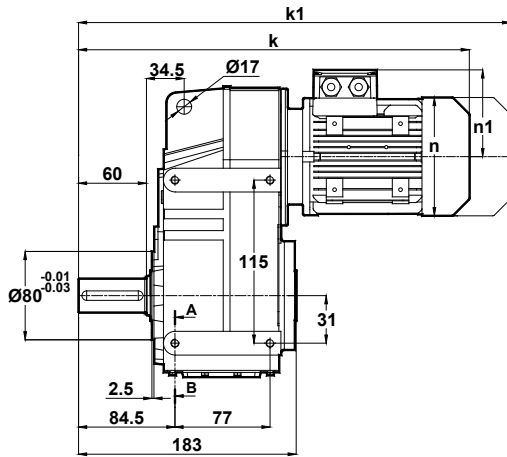

Klemens Pozisyonları  
Terminal Box Positions  
Klemmenkasten Positionen

	63	71	80	90S	90L	100L
k	371	400	434	473	473	521
k1	432	491	527	577.5	577.5	640.5
n	121	137	155	176	176	193
n1	97	112	121	132	132	147
p1	286	301	310	321	321	336

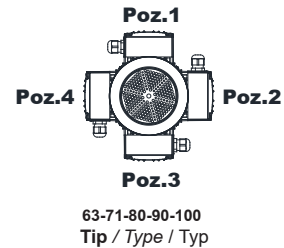

"k1" ölçüsü frenli redüktörlere aittir.  
Dimensions "k1" is for motors with brake.  
Maße "k1" ist für Bremsenmotoren.

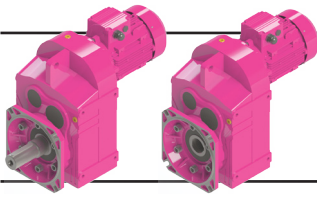

# Ölçü Sayfaları Dimension Pages Abmessungsseiten

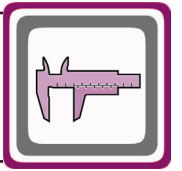

Mil ucu çektirme deliği DIN 332 sayfa 2 / Tapped center hole according to DIN 332, sheet 2 / Zentrierung mit Gewinde nach DIN 332, Blatt 2

DR172.02  
DR173.02

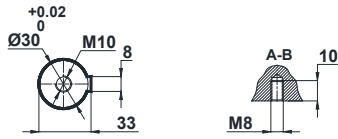
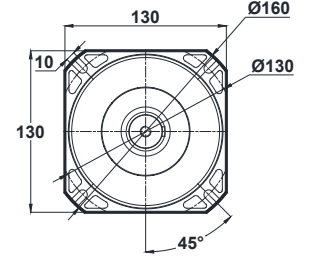
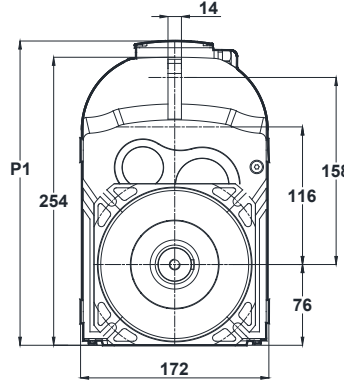
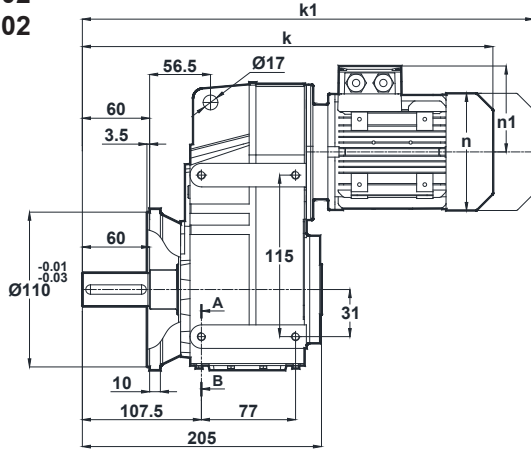

Klemens Pozisyonları  
Terminal Box Positions  
Klemmenkasten Positionen

Opsiyonel Flanş Ölçüleri  
Optional Flange Dimensions  
Auswählbare Flanschabmessungen

	63	71	80	90S	90L	100L
k	393	422	456	495	495	543
k1	454	513	549	599.5	599.5	662.5
n	121	137	155	176	176	193
n1	97	112	121	132	132	147
p1	286	301	310	321	321	336

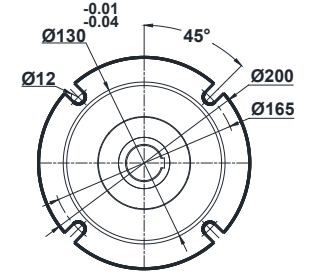
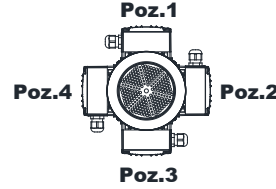

63-71-80-90-100  
Tip / Type / Typ

DR172.03  
DR173.03

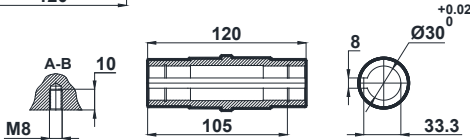
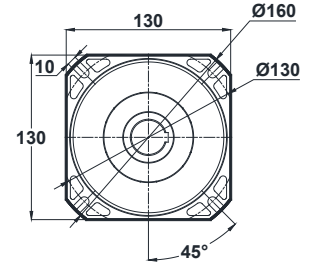
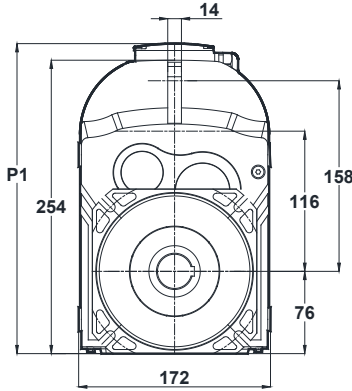
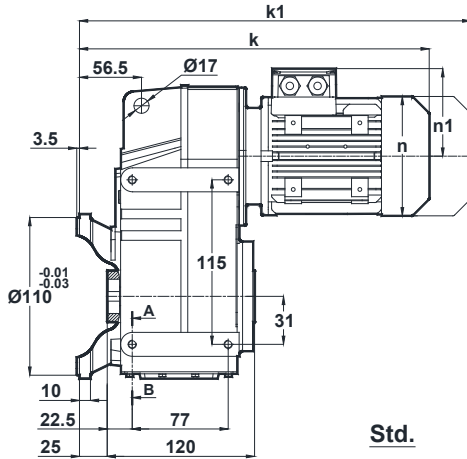

Klemens Pozisyonları  
Terminal Box Positions  
Klemmenkasten Positionen

Opsiyonel Flanş Ölçüleri  
Optional Flange Dimensions  
Auswählbare Flanschabmessungen

	63	71	80	90S	90L	100L
k	333	362	396	435	435	483
k1	394	453	489	539.5	539.5	602.5
n	121	137	155	176	176	193
n1	97	112	121	132	132	147
p1	286	301	310	321	321	336

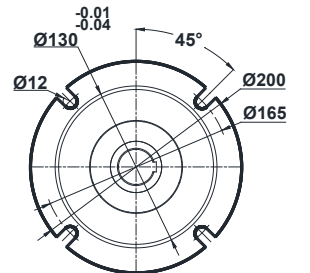
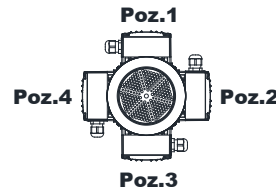

63-71-80-90-100  
Tip / Type / Typ

"k1" ölçüsü frenli redüktörlere aittir.  
Dimensions "k1" is for motors with brake.  
Maße "k1" ist für Bremsenmotoren.

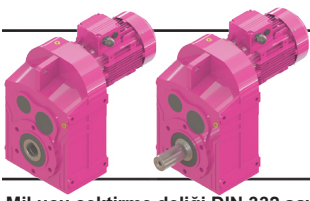

# Ölçü Sayfaları Dimension Pages Abmessungsseiten

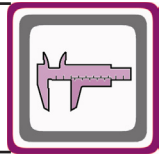

Mil ucu çekirtme deliği DIN 332 sayfa 2 / Tapped center hole according to DIN 332, sheet 2 / Zentrierung mit Gewinde nach DIN 332, Blatt 2

DR272.00  
DR273.00

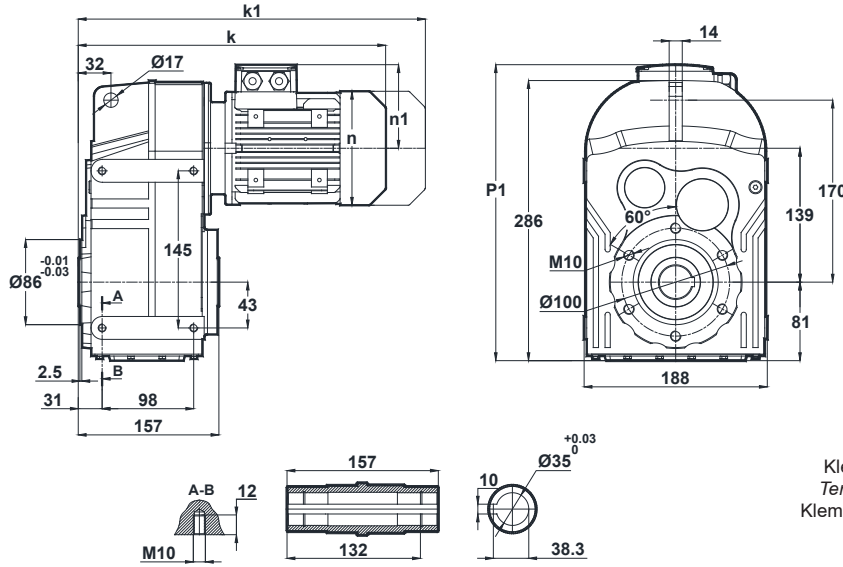

Klemens Pozisyonları  
Terminal Box Positions  
Klemmenkasten Positionen

	63	71	80	90S	90L	100L
k	338	367	401	440	440	488
k1	399	458	494	544.5	544.5	607.5
n	121	137	155	176	176	193
n1	97	112	121	132	132	147
p1	317	332	341	352	352	367

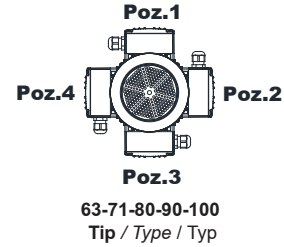

DR272.01  
DR273.01

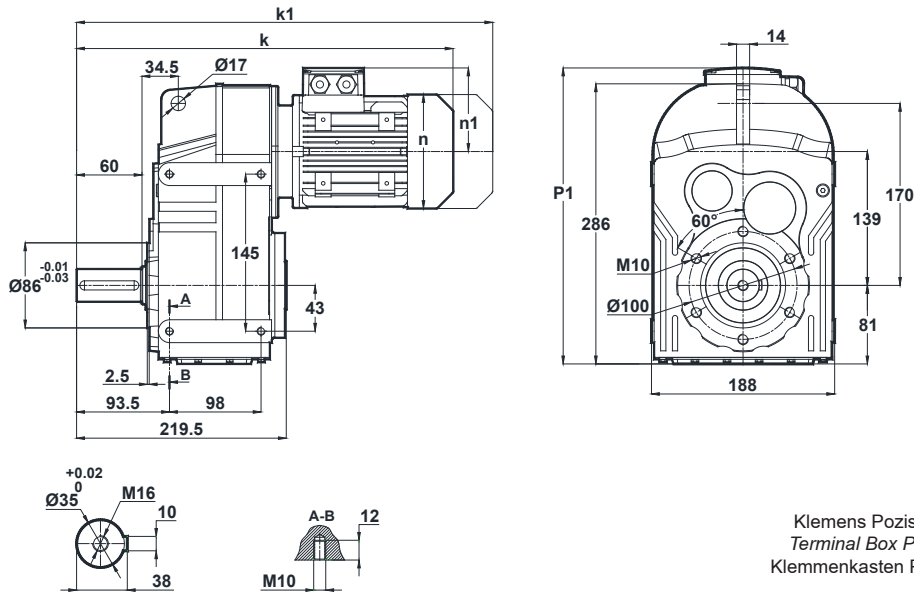

Klemens Pozisyonları  
Terminal Box Positions  
Klemmenkasten Positionen

	63	71	80	90S	90L	100L
k	400	429	463	502	502	550
k1	461	520	556	606.5	606.5	669.5
n	121	137	155	176	176	193
n1	97	112	121	132	132	147
p1	317	332	341	352	352	367

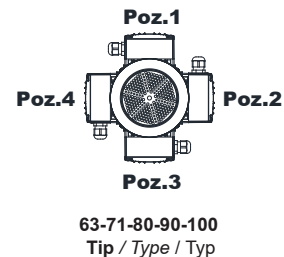

"k1" ölçüsü frenli redüktörlere aittir.  
Dimensions "k1" is for motors with brake.  
Maße "k1" ist für Bremsenmotoren.

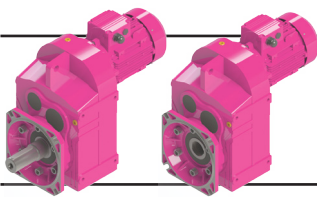

# Ölçü Sayfaları Dimension Pages Abmessungsseiten

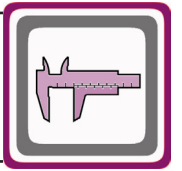

Mil ucu çektirme deliği DIN 332 sayfa 2 / Tapped center hole according to DIN 332, sheet 2 / Zentrierung mit Gewinde nach DIN 332, Blatt 2

DR272.02  
DR273.02

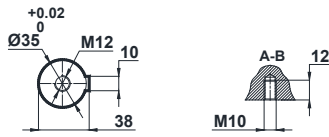
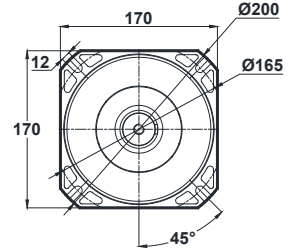
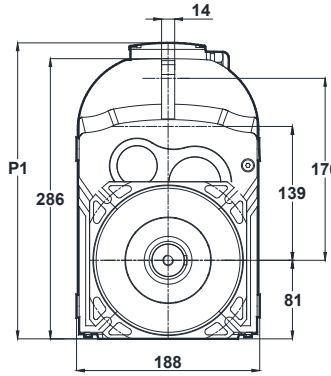
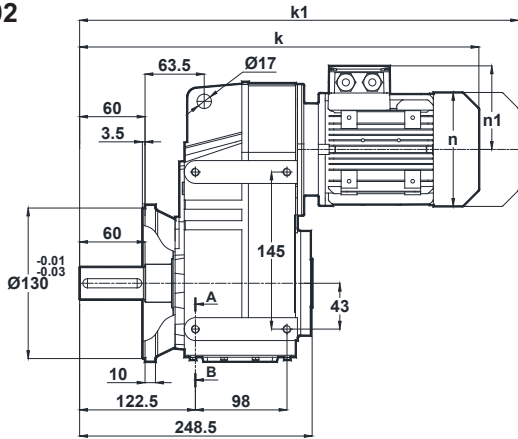

Klemens Pozisyonları  
Terminal Box Positions  
Klemmenkasten Positionen

Opsiyonel Flanş Ölçüleri  
Optional Flange Dimensions  
Auswählbare Flanschabmessungen

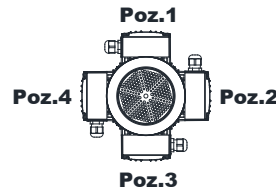

63-71-80-90-100  
Tip / Type / Typ

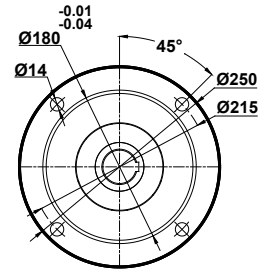

	63	71	80	90S	90L	100L
k	429	458	492	531	531	579
k1	490	549	585	635.5	635.5	698.5
n	121	137	155	176	176	193
n1	97	112	121	132	132	147
p1	317	332	341	352	352	367

DR272.03  
DR273.03

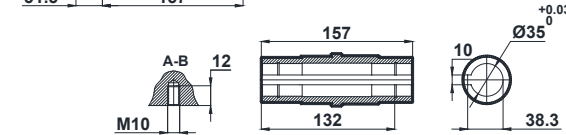
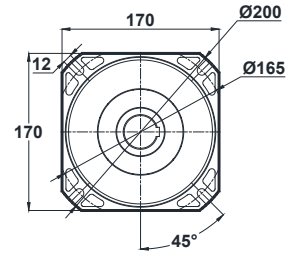
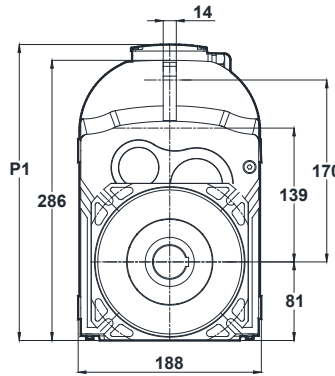
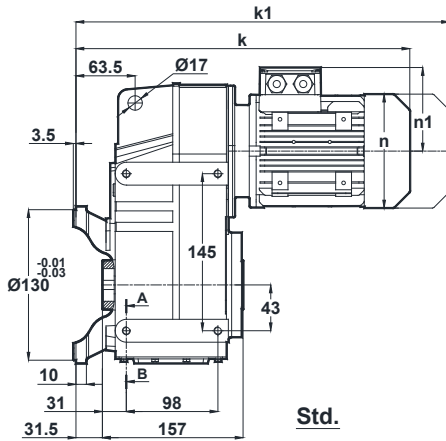

Klemens Pozisyonları  
Terminal Box Positions  
Klemmenkasten Positionen

Opsiyonel Flanş Ölçüleri  
Optional Flange Dimensions  
Auswählbare Flanschabmessungen

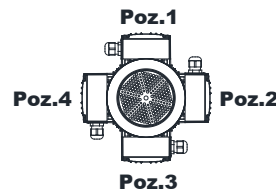

63-71-80-90-100  
Tip / Type / Typ

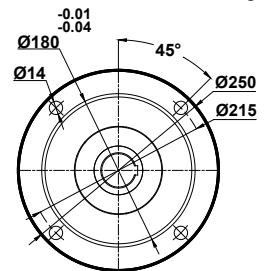

	63	71	80	90S	90L	100L
k	369	398	432	471	471	737
k1	430	489	525	575.5	575.5	856.5
n	121	137	155	176	176	193
n1	97	112	121	132	132	147
p1	317	332	341	352	352	367

"k1" ölçüsü frenli redüktörlere aittir.  
Dimensions "k1" is for motors with brake.  
Maße "k1" ist für Bremsenmotoren.

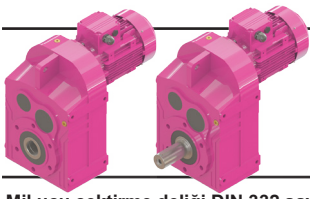

# Ölçü Sayfaları Dimension Pages Abmessungsseiten

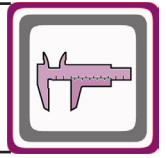

Mil ucu çektirme deliği DIN 332 sayfa 2 / Tapped center hole according to DIN 332, sheet 2 / Zentrierung mit Gewinde nach DIN 332, Blatt 2

DR275.00  
DR276.00

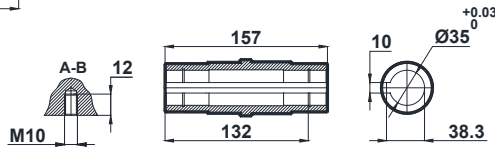
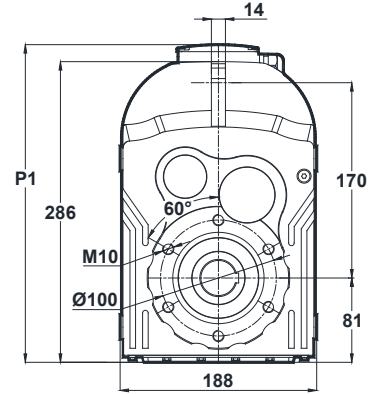
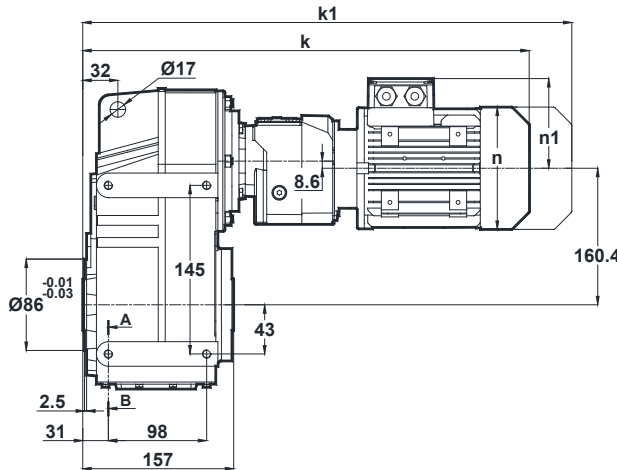

	63	71
k	484	513
k1	545	604
n	121	137
n1	97	112
p1	309	324

Klemens Pozisyonları  
Terminal Box Positions  
Klemmenkasten Positionen

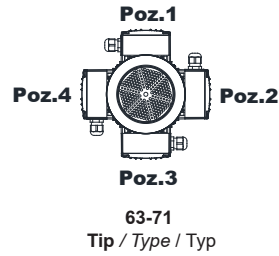

DR275.01  
DR276.01

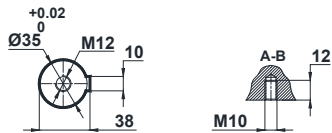
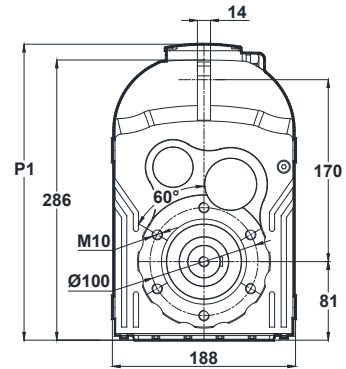
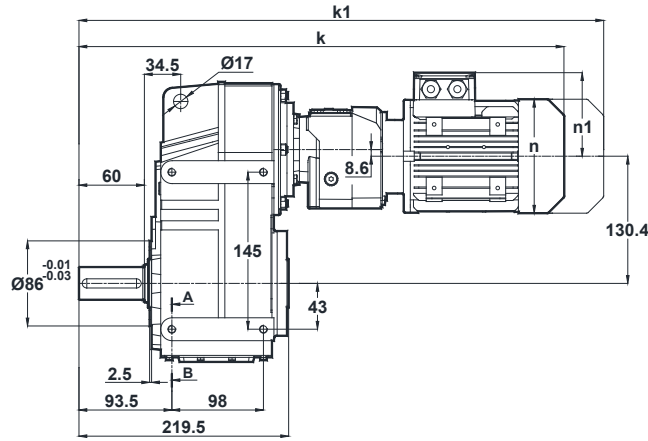

	63	71
k	546	575
k1	607	666
n	121	137
n1	97	112
p1	309	324

Klemens Pozisyonları  
Terminal Box Positions  
Klemmenkasten Positionen

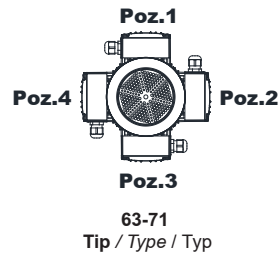

"k1" ölçüsü frenli redüktörlere aittir.  
Dimensions "k1" is for motors with brake.  
Maße "k1" ist für Bremsenmotoren.

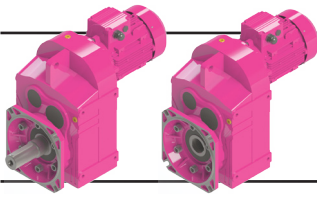

# Ölçü Sayfaları Dimension Pages Abmessungsseiten

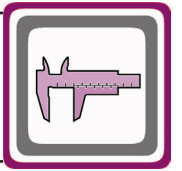

Mil ucu çektirme deliği DIN 332 sayfa 2 / Tapped center hole according to DIN 332, sheet 2 / Zentrierung mit Gewinde nach DIN 332, Blatt 2

DR275.02  
DR276.02

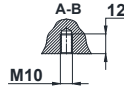
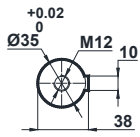
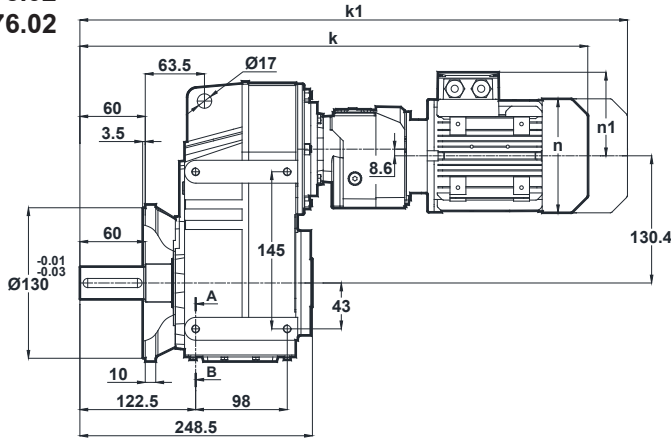

	63	71
k	575	604
k1	636	695
n	121	137
n1	97	112
p1	309	324

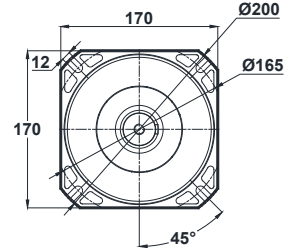
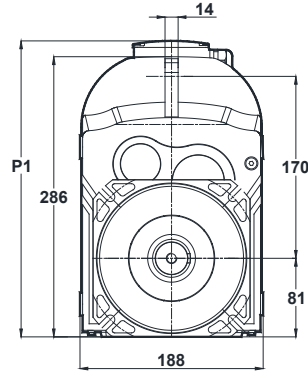

Klemens Pozisyonları  
Terminal Box Positions  
Klemmenkasten Positionen

Opsiyonel Flaş Ölçüleri  
Optional Flange Dimensions  
Auswählbare Flanschabmessungen

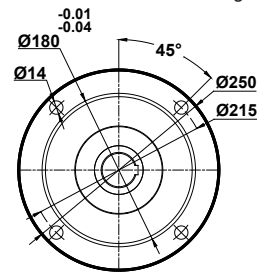
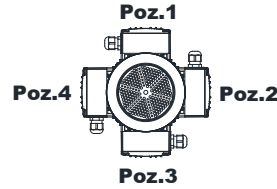

63-71  
Tip / Type / Typ

DR275.03  
DR276.03

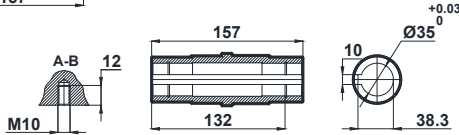
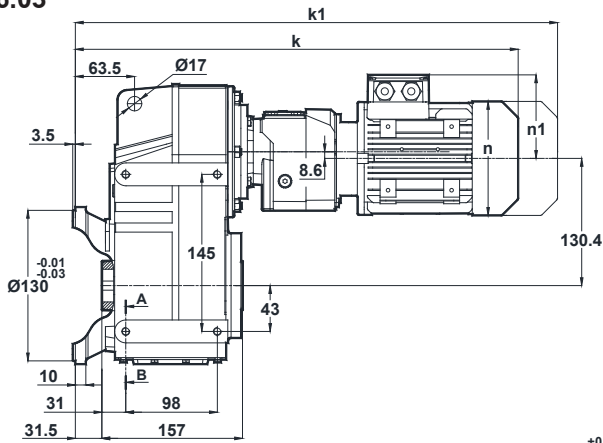

	63	71
k	515	544
k1	576	635
n	121	137
n1	97	112
p1	309	324

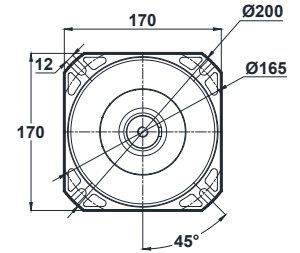
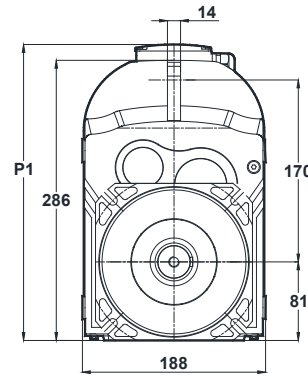

Klemens Pozisyonları  
Terminal Box Positions  
Klemmenkasten Positionen

Opsiyonel Flaş Ölçüleri  
Optional Flange Dimensions  
Auswählbare Flanschabmessungen

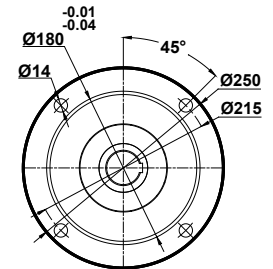
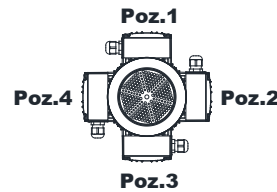

63-71  
Tip / Type / Typ

"k1" ölçüsü frenli redüktörlere aittir.  
Dimensions "k1" is for motors with brake.  
Maße "k1" ist für Bremsenmotoren.

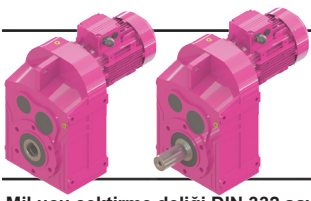

# Ölçü Sayfaları

## Dimension Pages

### Abmessungsseiten

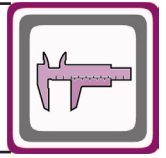

Mil ucu çektirme deliği DIN 332 sayfa 2 / Tapped center hole according to DIN 332, sheet 2 / Zentrierung mit Gewinde nach DIN 332, Blatt 2

DR282.00  
DR283.00

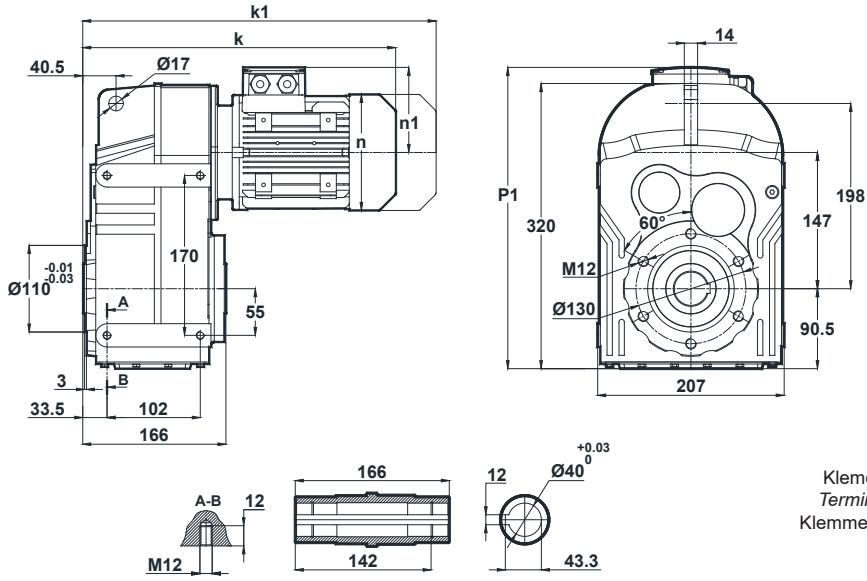

Klemens Pozisyonları  
Terminal Box Positions  
Klemmenkasten Positionen

	71	80	90S	90L	100L	112M	132S	132M
k	370	404	443	443	491	515	598	598
k1	461	497	547.5	547.5	610.5	619.5	728	728
n	137	155	176	176	193	215	257	257
n1	112	121	132	132	147	158	179	179
p1	349	358	369	369	384	395	417	417

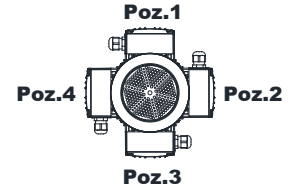

71-80-90-100-112-132  
Tip / Type / Typ

DR282.01  
DR283.01

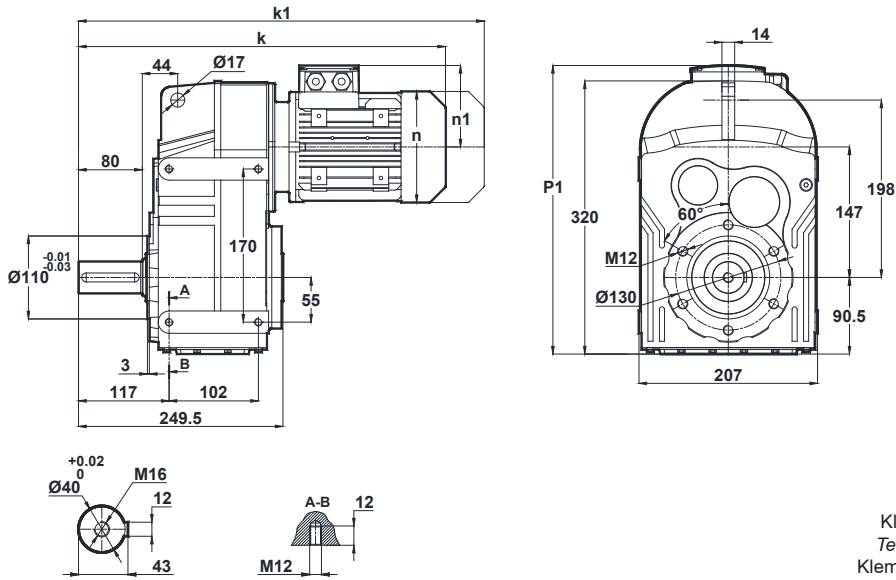

Klemens Pozisyonları  
Terminal Box Positions  
Klemmenkasten Positionen

	71	80	90S	90L	100L	112M	132S	132M
k	454	488	527	527	575	599	682	682
k1	545	581	631.5	631.5	694.5	703.5	812	812
n	137	155	176	176	193	215	257	257
n1	112	121	132	132	147	158	179	179
p1	349	358	369	369	384	395	417	417

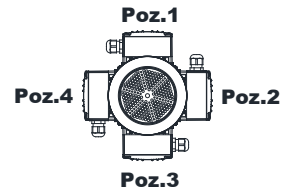

71-80-90-100-112-132  
Tip / Type / Typ

"k1" ölçüsü frenli redüktörlere aittir.  
Dimensions "k1" is for motors with brake.  
Maße "k1" ist für Bremsenmotoren.

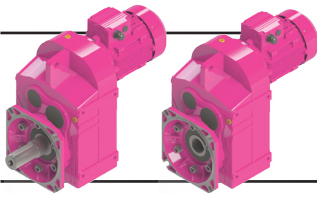

# Ölçü Sayfaları Dimension Pages Abmessungsseiten

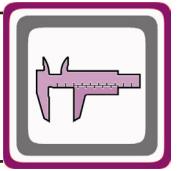

Mil ucu çektirme deliği DIN 332 sayfa 2 / Tapped center hole according to DIN 332, sheet 2 / Zentrierung mit Gewinde nach DIN 332, Blatt 2

DR282.02  
DR283.02

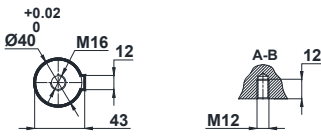
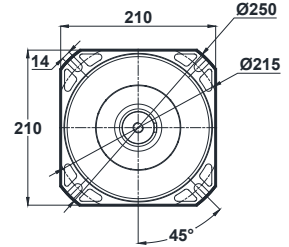
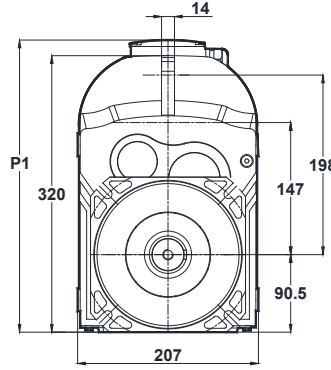
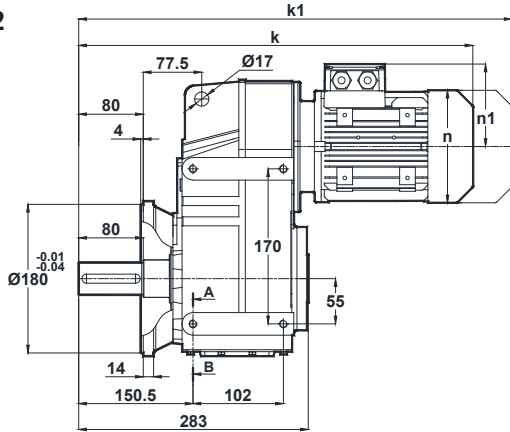

Klemens Pozisyonları  
Terminal Box Positions  
Klemmenkasten Positionen

Opsiyonel Flaş Ölçüleri  
Optional Flange Dimensions  
Auswählbare Flanschabmessungen

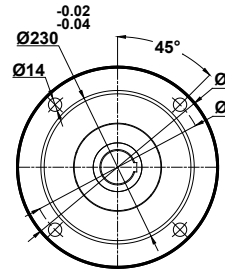
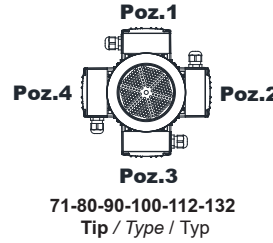

	71	80	90S	90L	100L	112M	132S	132M
k	487	521	560	560	608	632	715	715
k1	578	614	664.5	664.5	727.5	736.5	845	845
n	137	155	176	176	193	215	257	257
n1	112	121	132	132	147	158	179	179
p1	349	358	369	369	384	395	417	417

DR282.03  
DR283.03

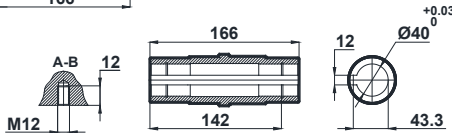
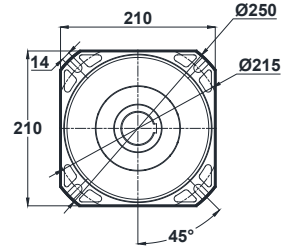
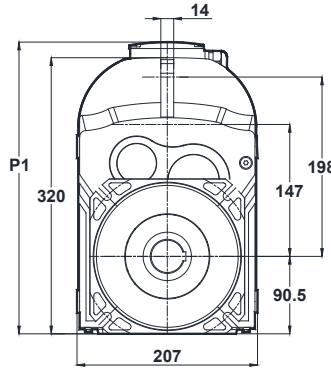
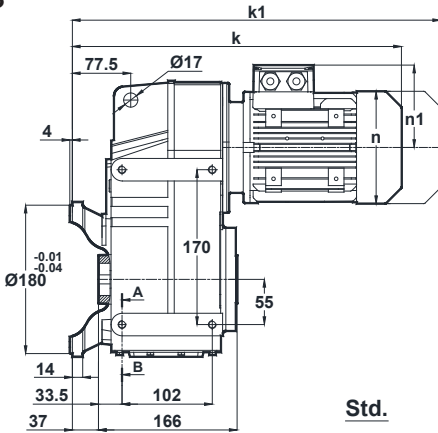

Klemens Pozisyonları  
Terminal Box Positions  
Klemmenkasten Positionen

Opsiyonel Flaş Ölçüleri  
Optional Flange Dimensions  
Auswählbare Flanschabmessungen

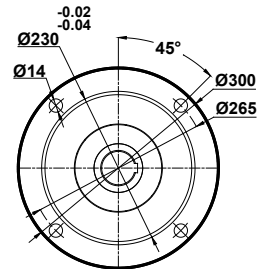
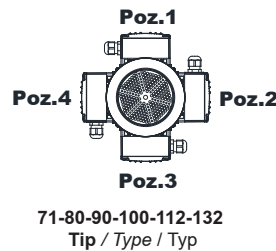

	71	80	90S	90L	100L	112M	132S	132M
k	407	441	480	480	528	552	635	635
k1	498	534	584.5	584.5	647.5	656.5	765	765
n	137	155	176	176	193	215	257	257
n1	112	121	132	132	147	158	179	179
p1	349	358	369	369	384	395	417	417

"k1" ölçüsü frenli redüktörlere aittir.  
Dimensions "k1" is for motors with brake.  
Maße "k1" ist für Bremsenmotoren.

Diğer opsiyonel flaş ölçüleri için sayfa 326'ya bakınız.  
Please see on page 326 for other optional flange dimensions  
Siehe Seite 326 für andere auswählbare Flanschabmessungen

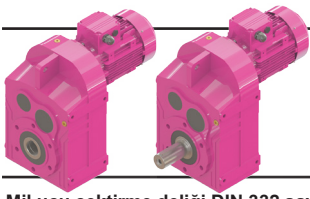

# Ölçü Sayfaları

## Dimension Pages

### Abmessungsseiten

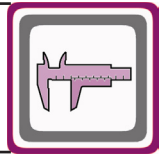

Mil ucu çektirme deliği DIN 332 sayfa 2 / Tapped center hole according to DIN 332, sheet 2 / Zentrierung mit Gewinde nach DIN 332, Blatt 2

DR285.00  
DR286.00

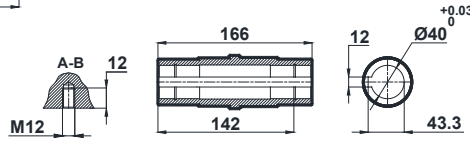
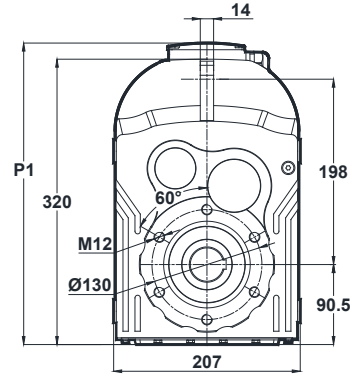
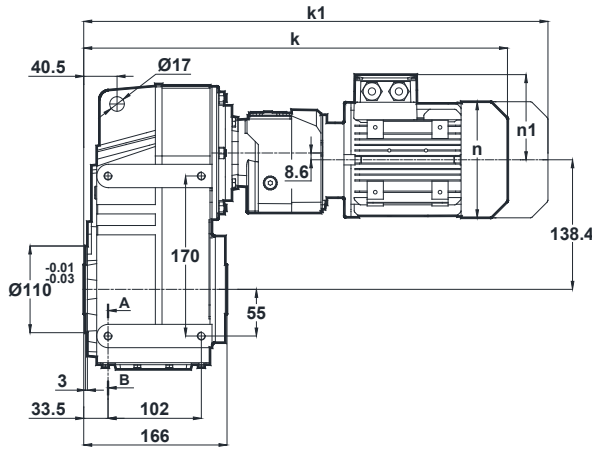

Klemens Pozisyonları  
Terminal Box Positions  
Klemmenkasten Positionen

	63	71
k	492	521
k1	553	612
n	121	137
n1	97	112
p1	326	341

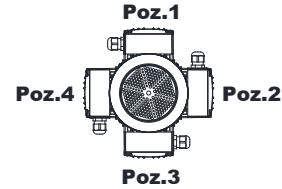

63-71  
Tip / Type / Typ

DR285.01  
DR286.01

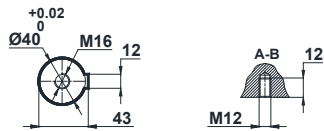
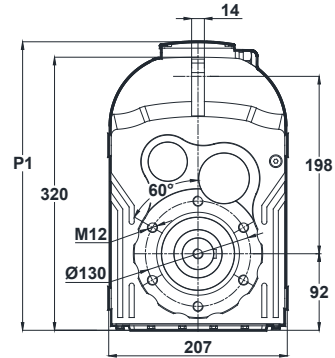
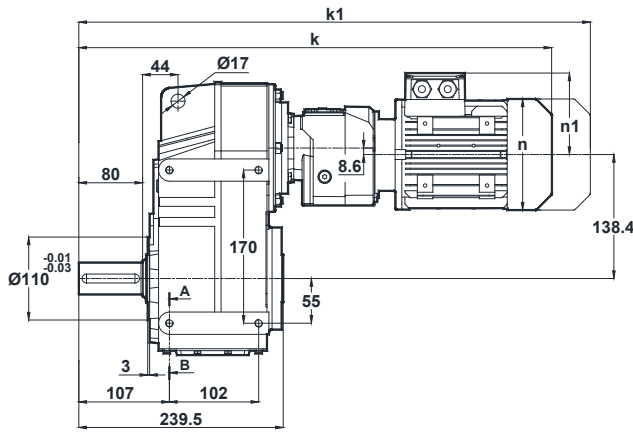

Klemens Pozisyonları  
Terminal Box Positions  
Klemmenkasten Positionen

	63	71
k	576	605
k1	637	696
n	121	137
n1	97	112
p1	326	341

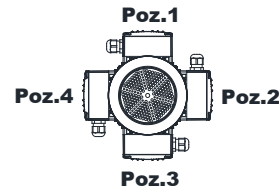

63-71  
Tip / Type / Typ

"k1" ölçüsü frenli redüktörlere aittir.  
Dimensions "k1" is for motors with brake.  
Maße "k1" ist für Bremsenmotoren.

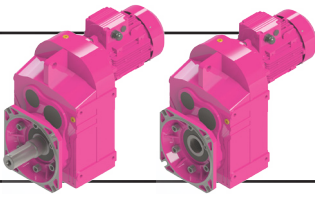

# Ölçü Sayfaları Dimension Pages Abmessungenseiten

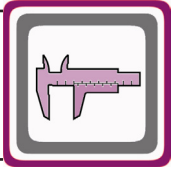

Mil ucu çektirme deliği DIN 332 sayfa 2 / Tapped center hole according to DIN 332, sheet 2 / Zentrierung mit Gewinde nach DIN 332, Blatt 2

DR285.02  
DR286.02

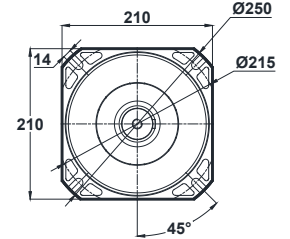
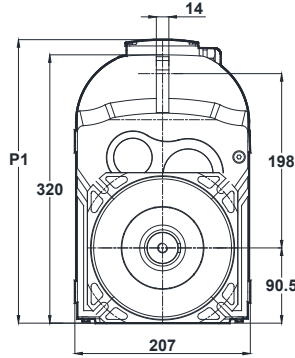
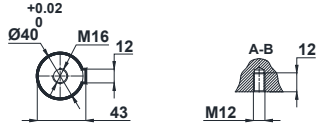
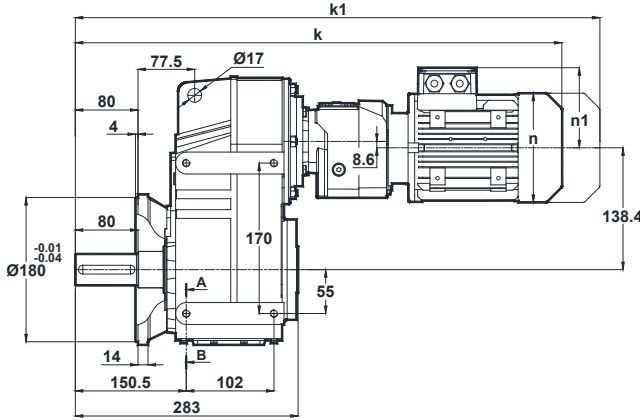

Klemens Pozisyonları  
Terminal Box Positions  
Klemmenkasten Positionen

Opsiyonel Flanş Ölçüleri  
Optional Flange Dimensions  
Auswählbare Flanschabmessungen

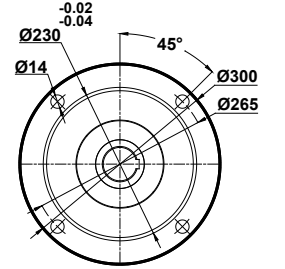
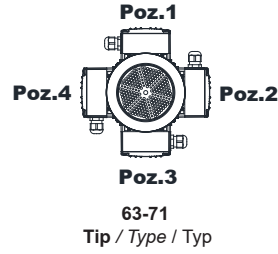

	63	71
k	609	638
k1	670	729
n	121	137
n1	97	112
p1	326	341

Diğer opsiyonel flanş ölçüleri için sayfa 326'ya bakınız.  
Please see on page 326 for other optional flange dimensions  
Siehe Seite 326 für andere auswählbare Flanschabmessungen

DR285.03  
DR286.03

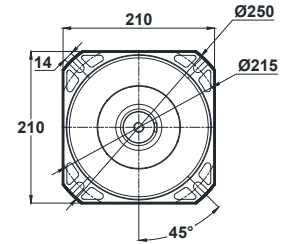
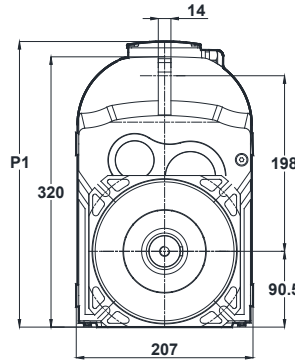
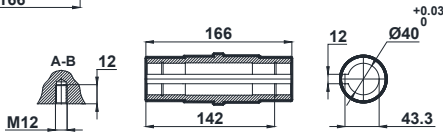
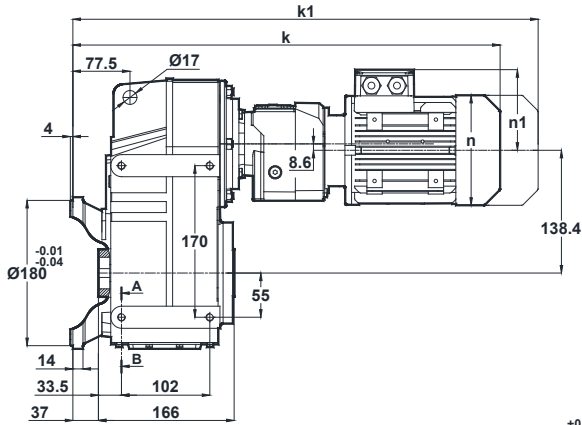

Klemens Pozisyonları  
Terminal Box Positions  
Klemmenkasten Positionen

Opsiyonel Flanş Ölçüleri  
Optional Flange Dimensions  
Auswählbare Flanschabmessungen

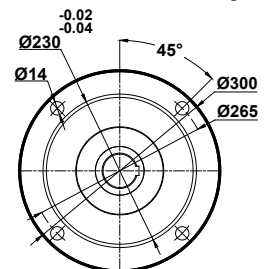
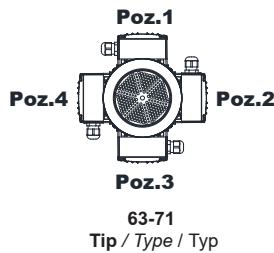

	63	71
k	529	558
k1	590	649
n	121	137
n1	97	112
p1	326	341

"k1" ölçüsü frenli redüktörlere aittir.  
Dimensions "k1" is for motors with brake.  
Maße "k1" ist für Bremsenmotoren.

Diğer opsiyonel flanş ölçüleri için sayfa 326'ya bakınız.  
Please see on page 326 for other optional flange dimensions  
Siehe Seite 326 für andere auswählbare Flanschabmessungen

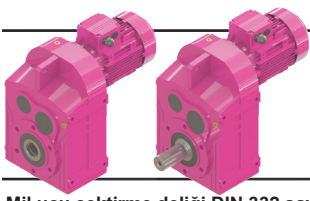

# Ölçü Sayfaları

## Dimension Pages

### Abmessungsseiten

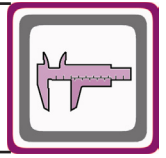

Mil ucu çektirme deliği DIN 332 sayfa 2 / Tapped center hole according to DIN 332, sheet 2 / Zentrierung mit Gewinde nach DIN 332, Blatt 2

DR372.00  
DR373.00

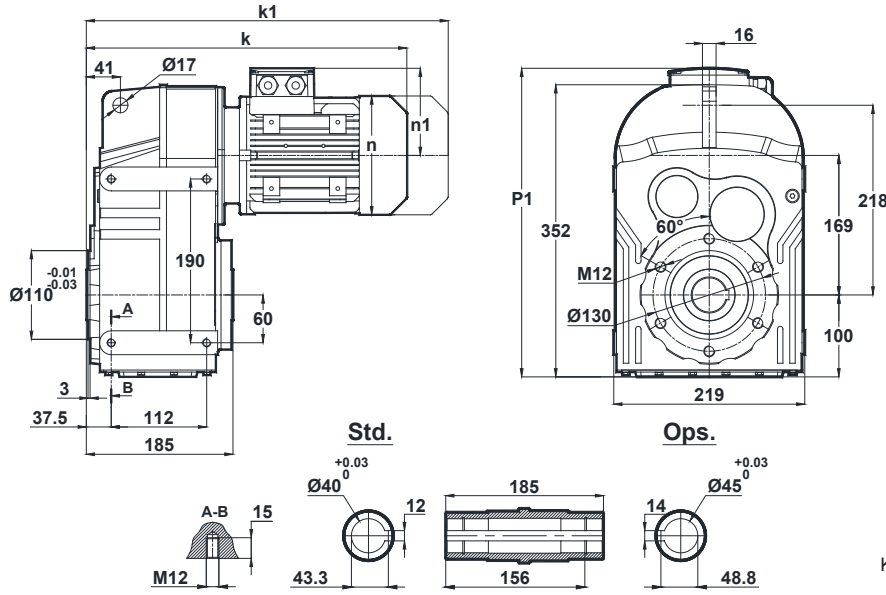

Klemens Pozisyonları  
Terminal Box Positions  
Klemmenkasten Positionen

	71	80	90S	90L	100L	112M	132S	132M
k	381	415	454	454	502	526	609	609
k1	472	508	558.5	558.5	621.5	630.5	739	739
n	137	155	176	176	193	215	257	257
n1	112	121	132	132	147	158	179	179
p1	381	390	401	401	416	427	448	448

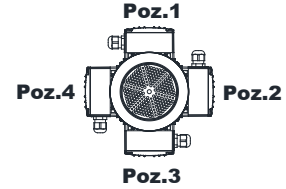

71-80-90-100-112-132  
Tip / Type / Typ

DR372.01  
DR373.01

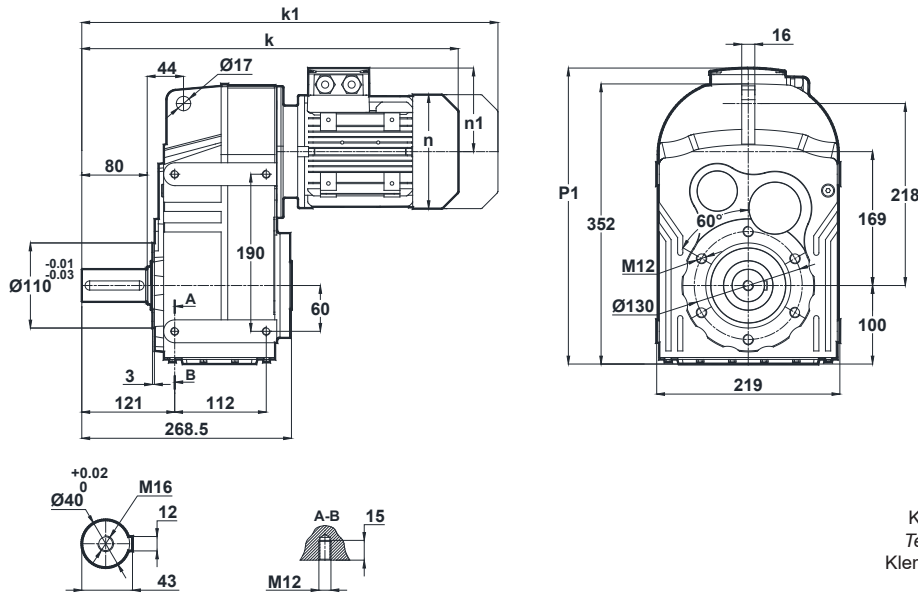

Klemens Pozisyonları  
Terminal Box Positions  
Klemmenkasten Positionen

	71	80	90S	90L	100L	112M	132S	132M
k	464	498	537	537	585	609	692	692
k1	555	591	641.5	641.5	704.5	713.5	822	822
n	137	155	176	176	193	215	257	257
n1	112	121	132	132	147	158	179	179
p1	381	390	401	401	416	427	448	448

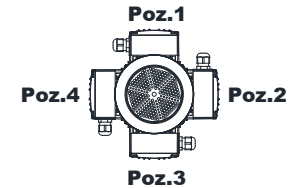

71-80-90-100-112-132  
Tip / Type / Typ

"k1" ölçüsü frenli redüktörlere aittir.  
Dimensions "k1" is for motors with brake.  
Maße "k1" ist für Bremsenmotoren.



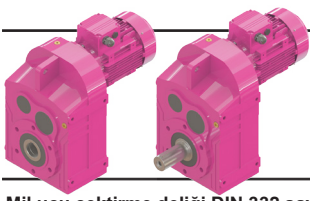

# Ölçü Sayfaları Dimension Pages Abmessungsseiten

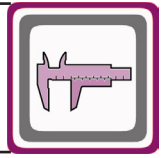

Mil ucu çektirme deliği DIN 332 sayfa 2 / Tapped center hole according to DIN 332, sheet 2 / Zentrierung mit Gewinde nach DIN 332, Blatt 2

DR375.00  
DR376.00

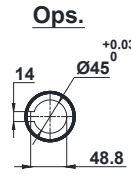
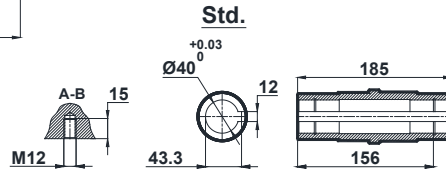
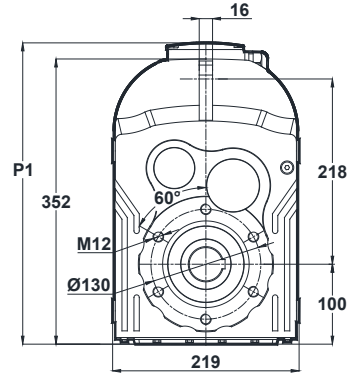
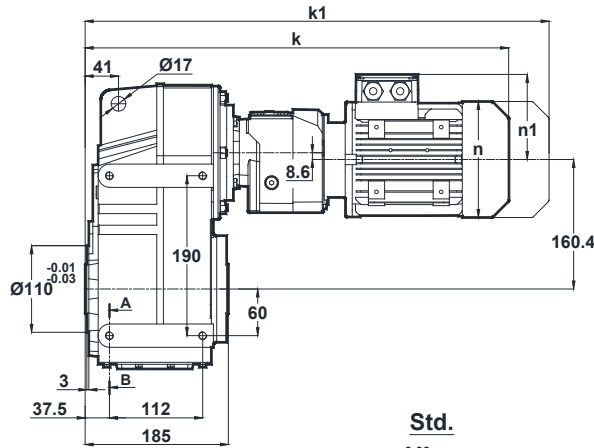

Klemens Pozisyonları  
Terminal Box Positions  
Klemmenkasten Positionen

	63	71	80
k	503	532	566
k1	564	623	659
n	121	137	155
n1	97	112	121
p1	358	373	382

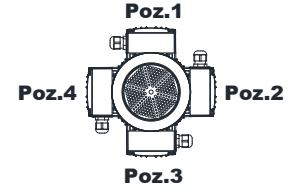

63-71-80  
Tip / Type / Typ

DR375.01  
DR376.01

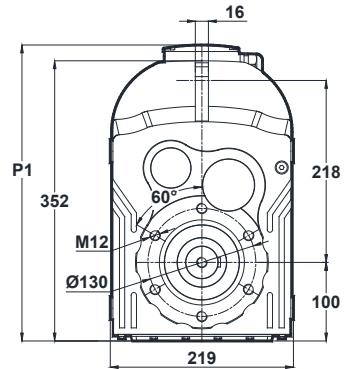
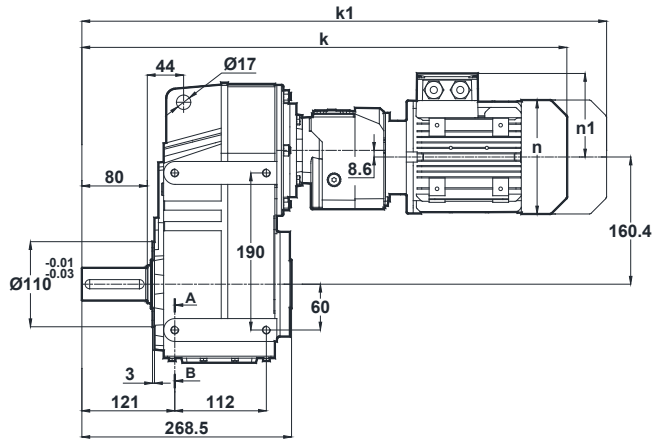

Klemens Pozisyonları  
Terminal Box Positions  
Klemmenkasten Positionen

	63	71	80
k	586	615	649
k1	647	706	742
n	121	137	155
n1	97	112	121
p1	358	373	382

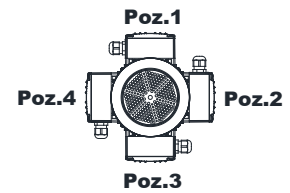

63-71-80  
Tip / Type / Typ

"k1" ölçüsü frenli redüktörlere aittir.  
Dimensions "k1" is for motors with brake.  
Maße "k1" ist für Bremsenmotoren.

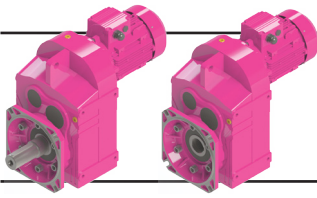

# Ölçü Sayfaları Dimension Pages Abmessungsseiten

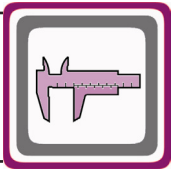

Mil ucu çektirme deliği DIN 332 sayfa 2 / Tapped center hole according to DIN 332, sheet 2 / Zentrierung mit Gewinde nach DIN 332, Blatt 2

DR375.02  
DR376.02

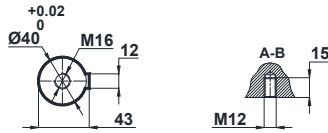
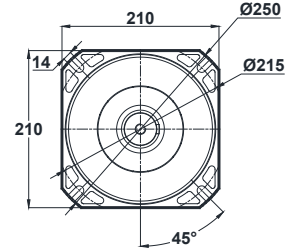
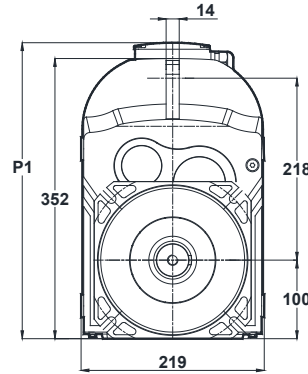
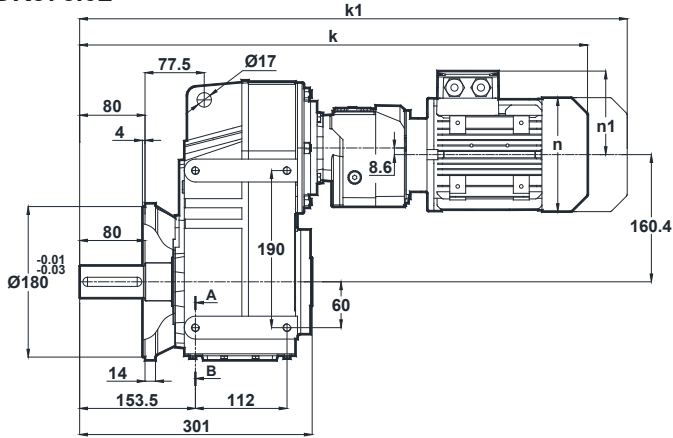

	63	71	80
k	619	648	682
k1	680	739	775
n	121	137	155
n1	97	112	121
p1	358	373	382

Klemens Pozisyonları  
Terminal Box Positions  
Klemmenkasten Positionen

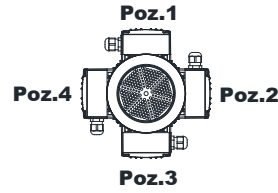

63-71-80  
Tip / Type / Typ

Opsiyonel Flanş Ölçüleri  
Optional Flange Dimensions  
Auswählbare Flanschabmessungen

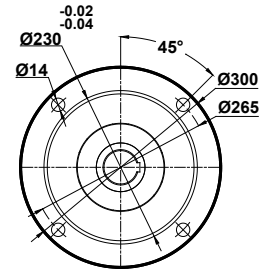

DR375.03  
DR376.03

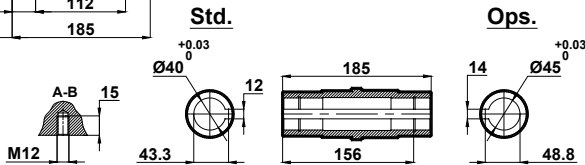
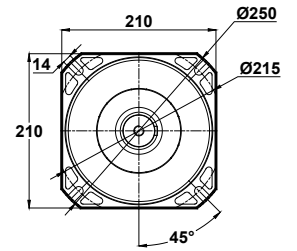
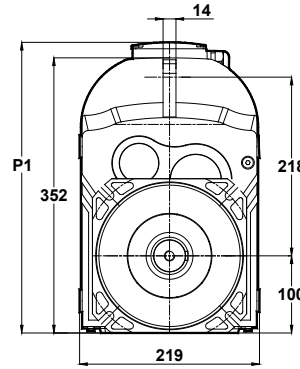
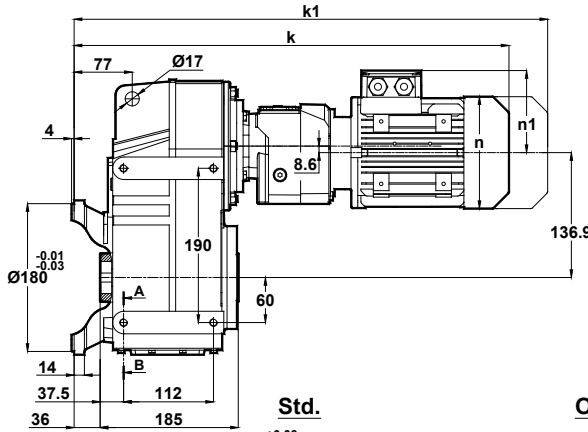

	63	71	80
k	539	568	602
k1	600	659	695
n	121	137	155
n1	97	112	121
p1	358	373	382

Klemens Pozisyonları  
Terminal Box Positions  
Klemmenkasten Positionen

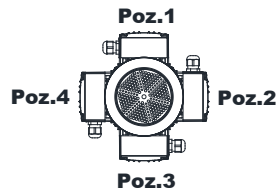

63-71-80  
Tip / Type / Typ

Opsiyonel Flanş Ölçüleri  
Optional Flange Dimensions  
Auswählbare Flanschabmessungen

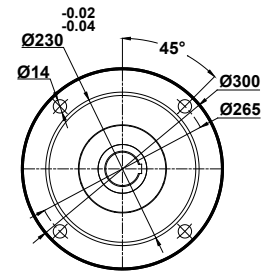

"k1" ölçüsü frenli redüktörlere aittir.  
Dimensions "k1" is for motors with brake.  
Maße "k1" ist für Bremsenmotoren.

Diğer opsiyonel flanş ölçüleri için sayfa 326'ya bakınız.  
Please see on page 326 for other optional flange dimensions  
Siehe Seite 326 für andere auswählbare Flanschabmessungen

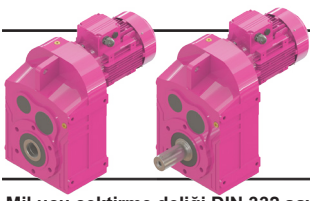

# Ölçü Sayfaları

## Dimension Pages

### Abmessungsseiten

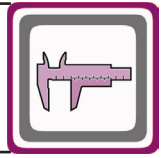

Mil ucu çektirme deliği DIN 332 sayfa 2 / Tapped center hole according to DIN 332, sheet 2 / Zentrierung mit Gewinde nach DIN 332, Blatt 2

DR472.00  
DR473.00

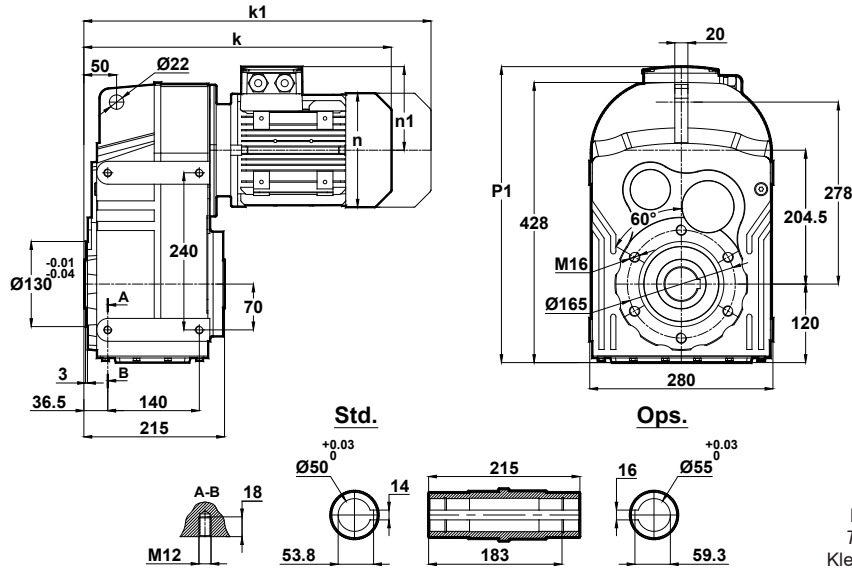

Klemens Pozisyonları  
Terminal Box Positions  
Klemmenkasten Positionen

	71	80	90S	90L	100L	112M	132S	132M	160M	160L
k	405	439	478	478	526	550	637	637	733	733
k1	496	532	582.5	582.5	645.5	645.5	767	767	913	913
n	137	155	176	176	193	215	257	257	315	315
n1	112	121	132	132	147	158	179	179	219	219
p1	437	446	457	457	472	483	504	504	544	544

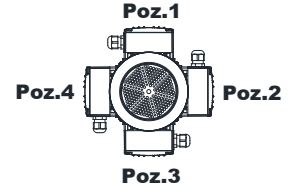

71-80-90-100-112-132-160  
Tip / Type / Typ

DR472.01  
DR473.01

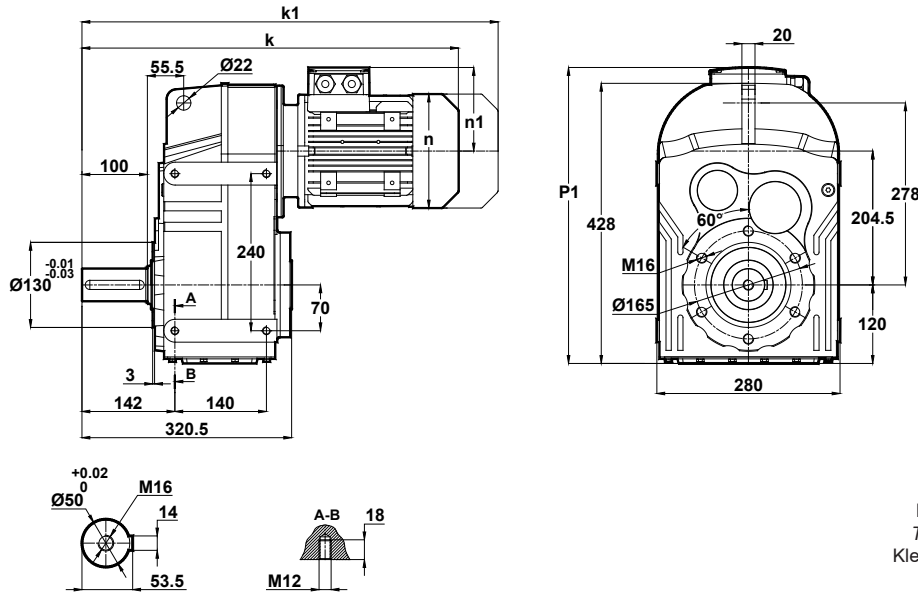

Klemens Pozisyonları  
Terminal Box Positions  
Klemmenkasten Positionen

	71	80	90S	90L	100L	112M	132S	132M	160M	160L
k	510	544	583	583	631	655	742	742	838	838
k1	601	637	687.5	687.5	750.5	759.5	872	872	1018	1018
n	137	155	176	176	193	215	257	257	315	315
n1	112	121	132	132	147	158	179	179	219	219
p1	437	446	457	457	472	483	504	504	544	544

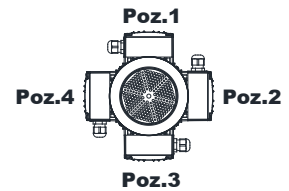

71-80-90-100-112-132-160  
Tip / Type / Typ

"k1" ölçüsü frenli redüktörlere aittir.  
Dimensions "k1" is for motors with brake.  
Maße "k1" ist für Bremsenmotoren.

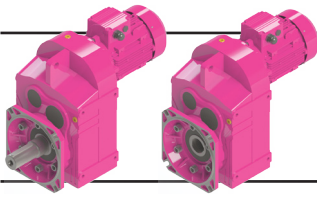

# Ölçü Sayfaları Dimension Pages Abmessungsseiten

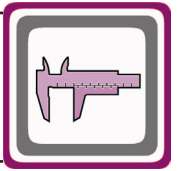

Mil ucu çektirme deliği DIN 332 sayfa 2 / Tapped center hole according to DIN 332, sheet 2 / Zentrierung mit Gewinde nach DIN 332, Blatt 2

DR472.02  
DR473.02

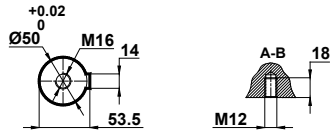
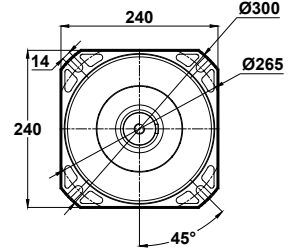
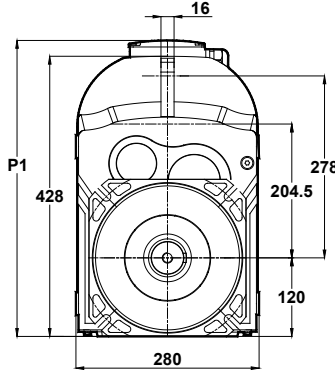
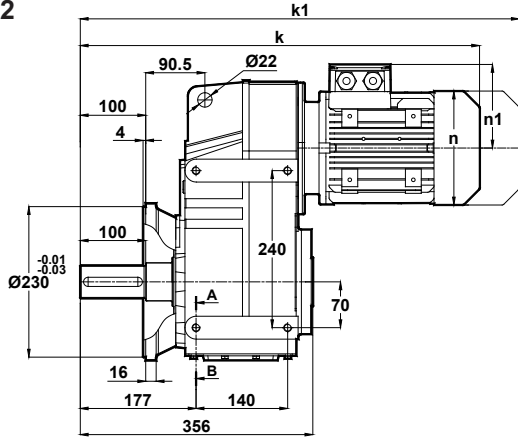

Klemens Pozisyonları  
Terminal Box Positions  
Klemmenkasten Positionen

Opsiyonel Flaş Ölçüleri  
Optional Flange Dimensions  
Auswählbare Flanschabmessungen

	71	80	90S	90L	100L	112M	132S	132M	160M	160L
k	545	579	618	618	666	690	777	777	873	873
k1	636	672	722.5	722.5	785.5	794.5	907	907	1053	1053
n	137	155	176	176	193	215	257	257	315	315
n1	112	121	132	132	147	158	179	179	219	219
p1	437	446	457	457	472	483	504	504	544	544

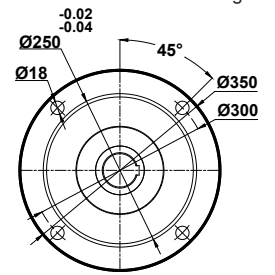
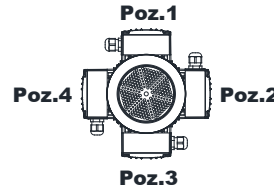

71-80-90-100-112-132-160  
Tip / Type / Typ

Diğer opsiyonel flaş ölçüleri için sayfa 326'ya bakınız.  
Please see on page 326 for other optional flange dimensions  
Siehe Seite 326 für andere auswählbare Flanschabmessungen

DR472.03  
DR473.03

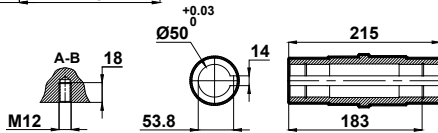
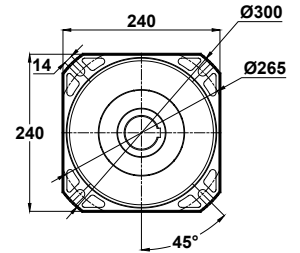
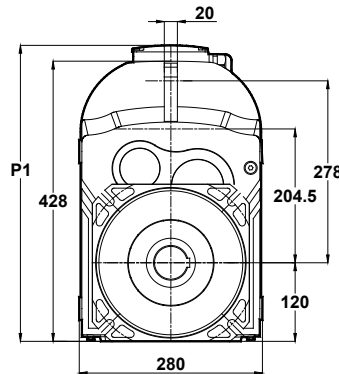
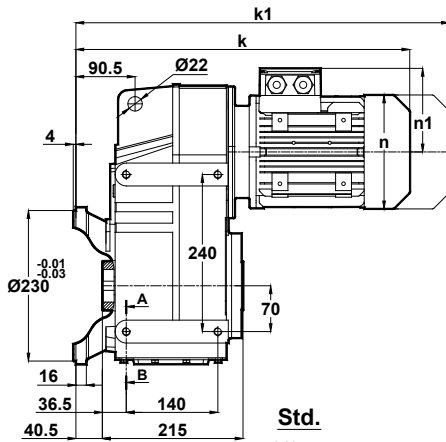

Klemens Pozisyonları  
Terminal Box Positions  
Klemmenkasten Positionen

Opsiyonel Flaş Ölçüleri  
Optional Flange Dimensions  
Auswählbare Flanschabmessungen

	71	80	90S	90L	100L	112M	132S	132M	160M	160L
k	445	479	518	518	566	590	677	677	773	773
k1	536	572	622.5	622.5	685.5	694.5	807	807	953	953
n	137	155	176	176	193	215	257	257	315	315
n1	112	121	132	132	147	158	179	179	219	219
p1	437	446	457	457	472	483	504	504	544	544

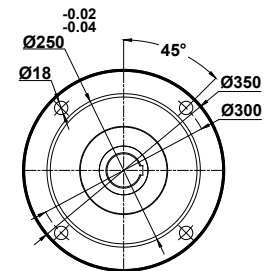
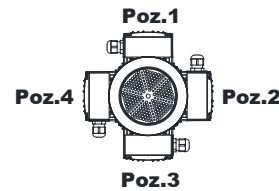

71-80-90-100-112-132-160  
Tip / Type / Typ

"k1" ölçüsü frenli redüktörlere aittir.  
Dimensions "k1" is for motors with brake.  
Maße "k1" ist für Bremsenmotoren.

Diğer opsiyonel flaş ölçüleri için sayfa 326'ya bakınız.  
Please see on page 326 for other optional flange dimensions  
Siehe Seite 326 für andere auswählbare Flanschabmessungen

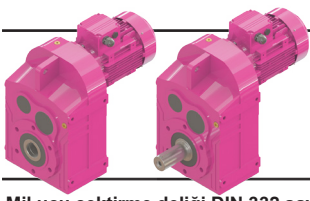

# Ölçü Sayfaları Dimension Pages Abmessungsseiten

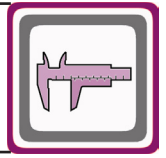

Mil ucu çektirme deliği DIN 332 sayfa 2 / Tapped center hole according to DIN 332, sheet 2 / Zentrierung mit Gewinde nach DIN 332, Blatt 2

DR474.00

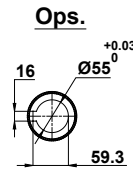
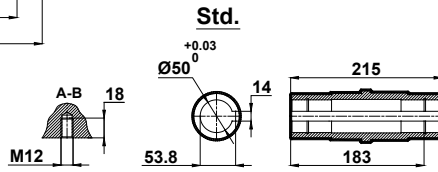
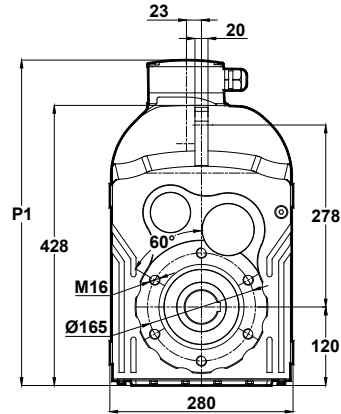
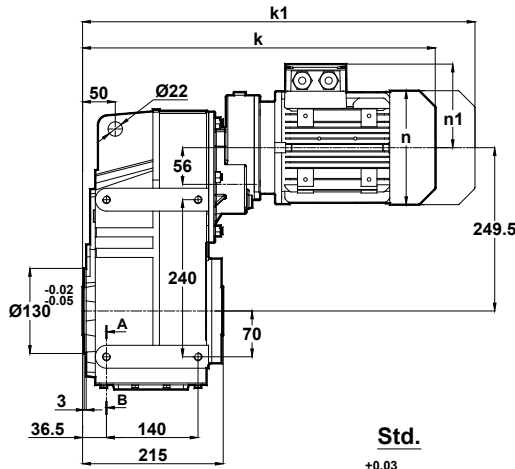

Klemens Pozisyonları  
Terminal Box Positions  
Klemmenkasten Positionen

	63	71	80
k	456	484	518
k1	517	575	611
n	121	137	155
n1	97	112	121
p1	467	482	491

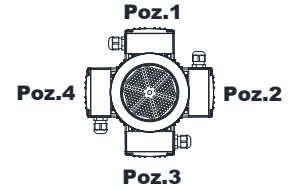

63-71-80  
Tip / Type / Typ

DR474.01

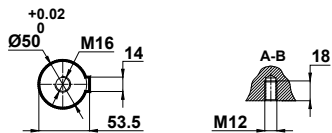
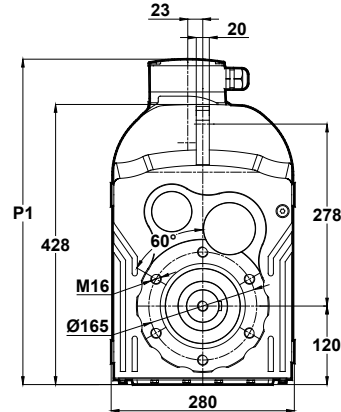
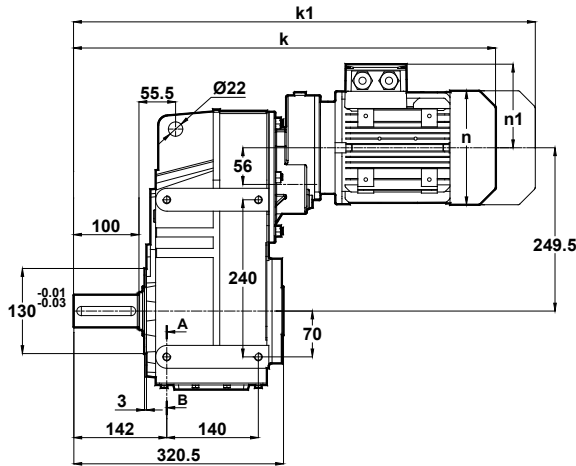

Klemens Pozisyonları  
Terminal Box Positions  
Klemmenkasten Positionen

	63	71	80
k	561	589	623
k1	622	680	716
n	121	137	155
n1	97	112	121
p1	467	482	491

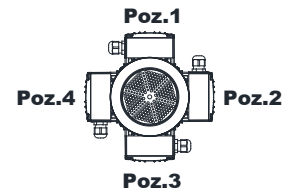

63-71-80  
Tip / Type / Typ

"k1" ölçüsü frenli redüktörlere aittir.  
Dimensions "k1" is for motors with brake.  
Maße "k1" ist für Bremsenmotoren.

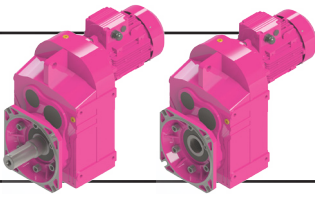

# Ölçü Sayfaları Dimension Pages Abmessungsseiten

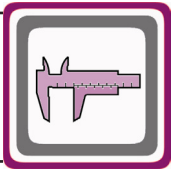

Mil ucu çektirme deliği DIN 332 sayfa 2 / Tapped center hole according to DIN 332, sheet 2 / Zentrierung mit Gewinde nach DIN 332, Blatt 2

## DR474.02

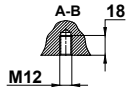
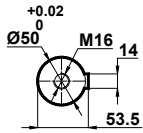
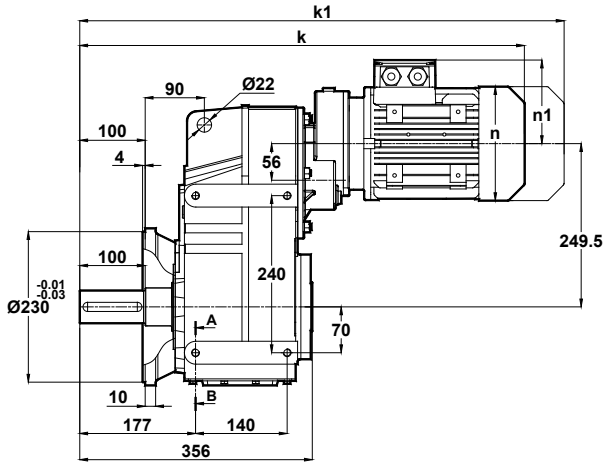

	63	71	80
k	596	624	658
k1	657	715	751
n	121	137	155
n1	97	112	121
p1	467	482	491

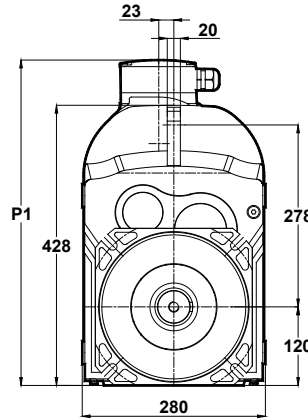

Klemens Pozisyonları  
Terminal Box Positions  
Klemmenkasten Positionen

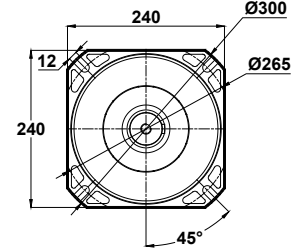

Opsiyonel Flanş Ölçüleri  
Optional Flange Dimensions  
Auswählbare Flanschabmessungen

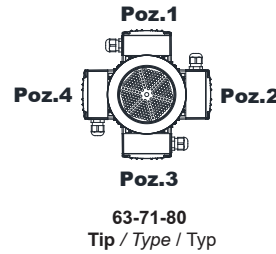

63-71-80  
Tip / Type / Typ

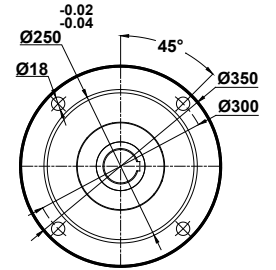

Diğer opsiyonel flanş ölçüleri için sayfa 326'ya bakınız.  
Please see on page 326 for other optional flange dimensions  
Siehe Seite 326 für andere auswählbare Flanschabmessungen

## DR474.03

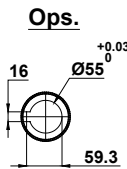
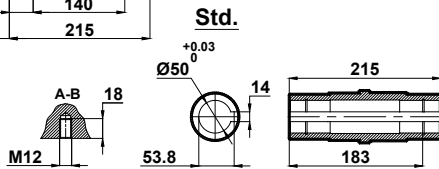
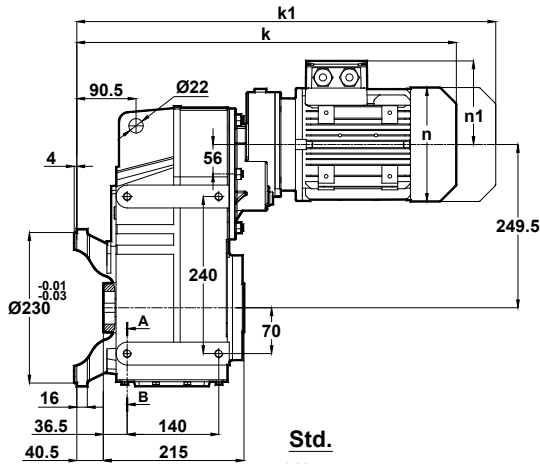

	63	71	80
k	496	524	558
k1	557	615	651
n	121	137	155
n1	97	112	121
p1	467	482	491

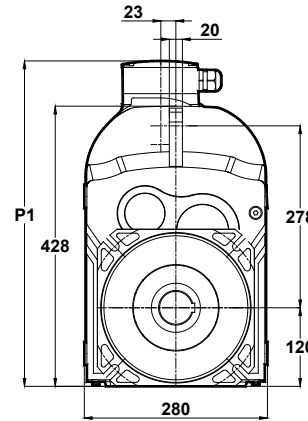

Klemens Pozisyonları  
Terminal Box Positions  
Klemmenkasten Positionen

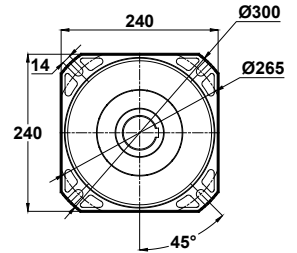

Opsiyonel Flanş Ölçüleri  
Optional Flange Dimensions  
Auswählbare Flanschabmessungen

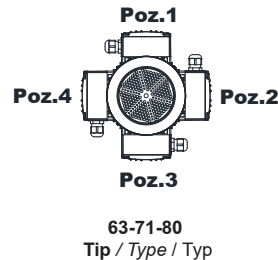

63-71-80  
Tip / Type / Typ

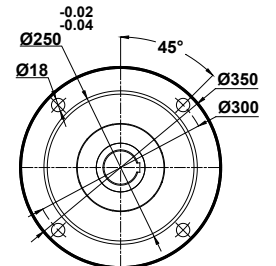

Diğer opsiyonel flanş ölçüleri için sayfa 326'ya bakınız.  
Please see on page 326 for other optional flange dimensions  
Siehe Seite 326 für andere auswählbare Flanschabmessungen

"k1" ölçüsü frenli redüktörlere aittir.  
Dimensions "k1" is for motors with brake.  
Maße "k1" ist für Bremsenmotoren.

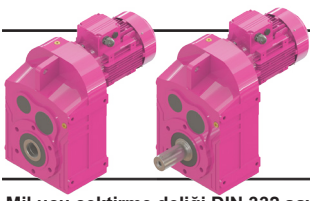

# Ölçü Sayfaları Dimension Pages Abmessungsseiten

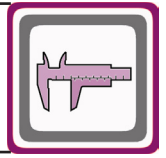

Mil ucu çektirme deliği DIN 332 sayfa 2 / Tapped center hole according to DIN 332, sheet 2 / Zentrierung mit Gewinde nach DIN 332, Blatt 2

DR475.00  
DR476.00

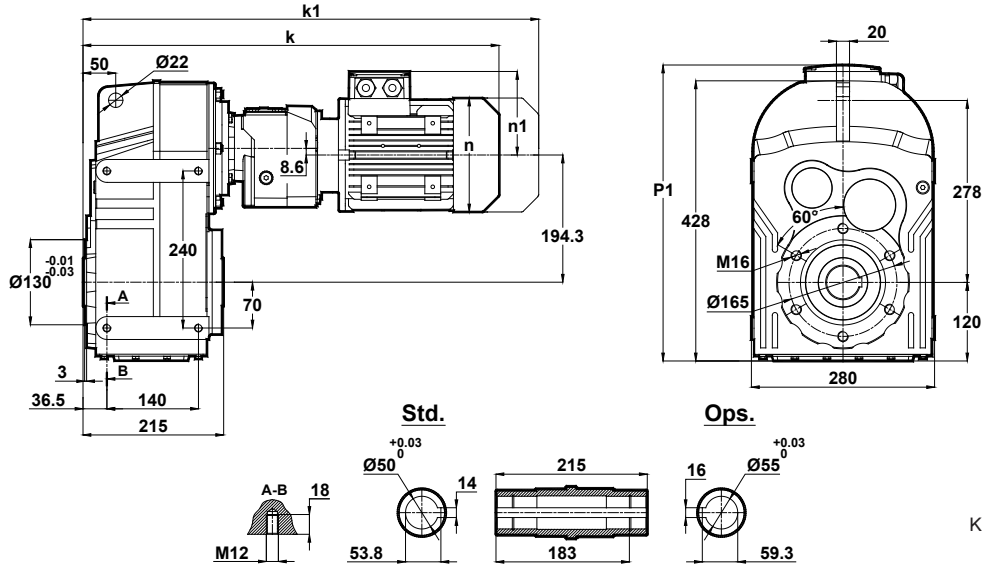

	63	71
k	558	585
k1	618	676
n	121	137
n1	97	112
p1	-	-

Klemens Pozisyonları  
Terminal Box Positions  
Klemmenkasten Positionen

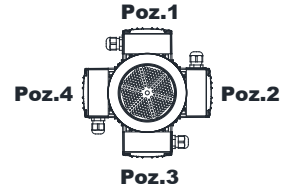

63-71  
Tip / Type / Typ

DR475.01  
DR476.01

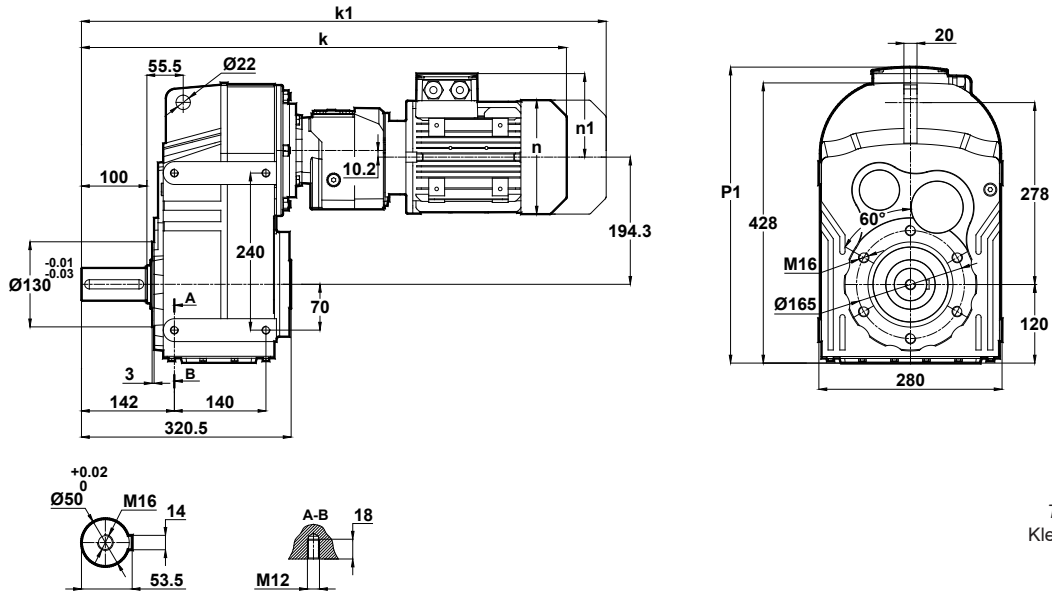

	63	71
k	663	690
k1	724	781
n	121	137
n1	97	112
p1	-	-

Klemens Pozisyonları  
Terminal Box Positions  
Klemmenkasten Positionen

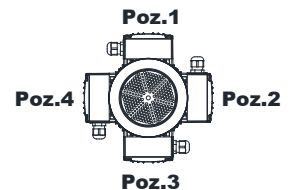

63-71  
Tip / Type / Typ

"k1" ölçüsü frenli redüktörlere aittir.  
Dimensions "k1" is for motors with brake.  
Maße "k1" ist für Bremsenmotoren.

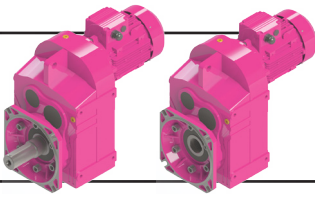

# Ölçü Sayfaları

## Dimension Pages

### Abmessungsseiten

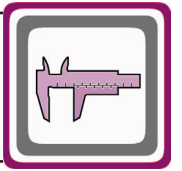

Mil ucu çektirme deliği DIN 332 sayfa 2 / Tapped center hole according to DIN 332, sheet 2 / Zentrierung mit Gewinde nach DIN 332, Blatt 2

DR475.02  
DR476.02

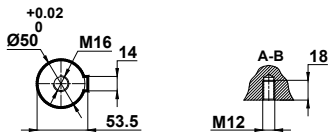
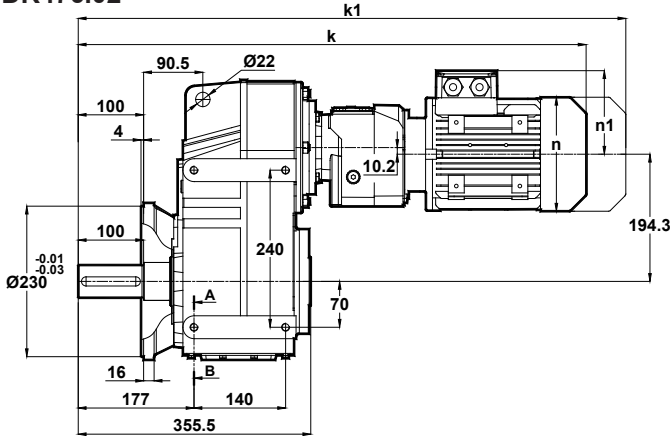

	63	71
k	698	725
k1	759	816
n	121	137
n1	97	112
p1	-	-

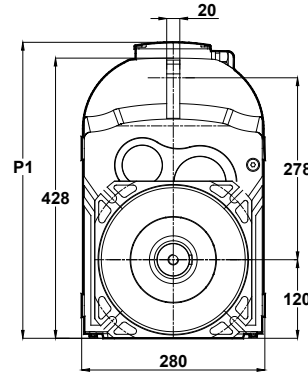

Klemens Pozisyonları  
Terminal Box Positions  
Klemmenkasten Positionen

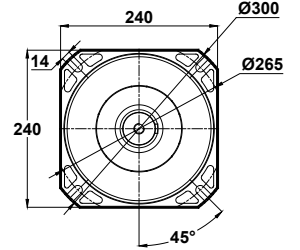

Opsiyonel Flanş Ölçüleri  
Optional Flange Dimensions  
Auswählbare Flanschabmessungen

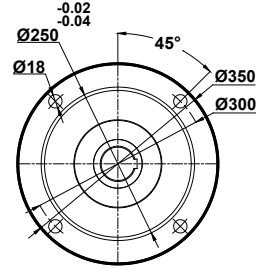
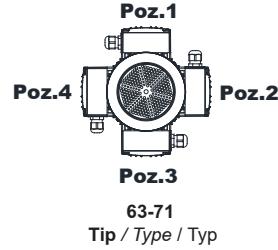

Diğer opsiyonel flanş ölçüleri için sayfa 326'ya bakınız.  
Please see on page 326 for other optional flange dimensions  
Siehe Seite 326 für andere auswählbare Flanschabmessungen

DR475.03  
DR476.03

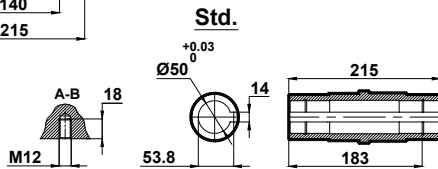
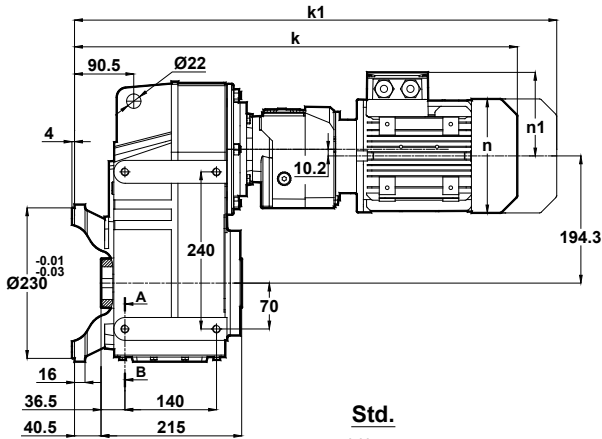

	63	71
k	598	625
k1	659	716
n	121	137
n1	97	112
p1	-	-

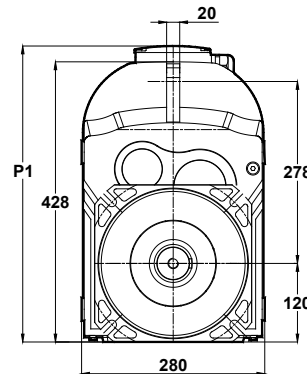

Ops.  
Klemens Pozisyonları  
Terminal Box Positions  
Klemmenkasten Positionen

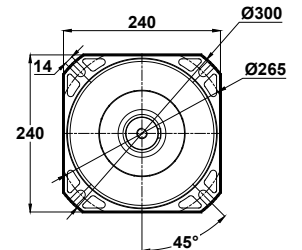

Opsiyonel Flanş Ölçüleri  
Optional Flange Dimensions  
Auswählbare Flanschabmessungen

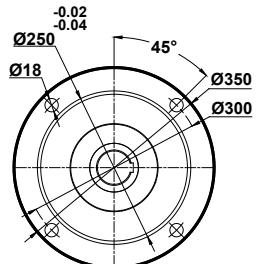
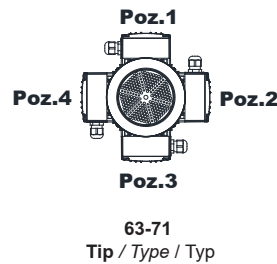

Diğer opsiyonel flanş ölçüleri için sayfa 326'ya bakınız.  
Please see on page 326 for other optional flange dimensions  
Siehe Seite 326 für andere auswählbare Flanschabmessungen

"k1" ölçüsü frenli redüktörlere aittir.  
Dimensions "k1" is for motors with brake.  
Maße "k1" ist für Bremsenmotoren.

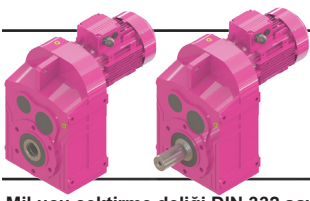

# Ölçü Sayfaları Dimension Pages Abmessungsseiten

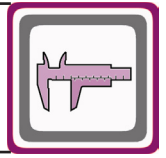

Mil ucu çektirme deliği DIN 332 sayfa 2 / Tapped center hole according to DIN 332, sheet 2 / Zentrierung mit Gewinde nach DIN 332, Blatt 2

DR572.00  
DR573.00

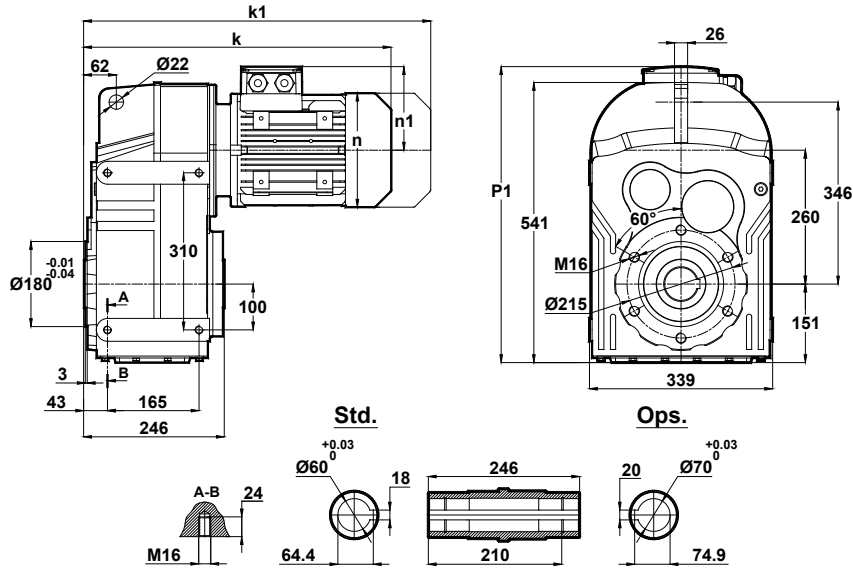

Klemens Pozisyonları  
Terminal Box Positions  
Klemmenkasten Positionen

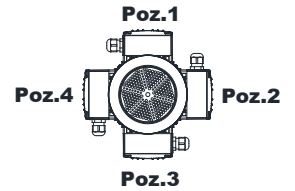

80-90-100-112-132-160-180  
Tip / Type / Typ

	80	90S	90L	100L	112M	132S	132M	160M	160L	180M	180L
k	461	500	500	544	569	654	654	750	750	821	821
k1	554	604.5	604.5	663.5	673.5	784	784	930	930	991.5	991.5
n	155	176	176	193	215	257	257	315	315	347	347
n1	121	132	132	147	158	179	179	219	219	234	234
p1	-	543	543	558	569	590	590	636	636	655	655

DR572.01  
DR573.01

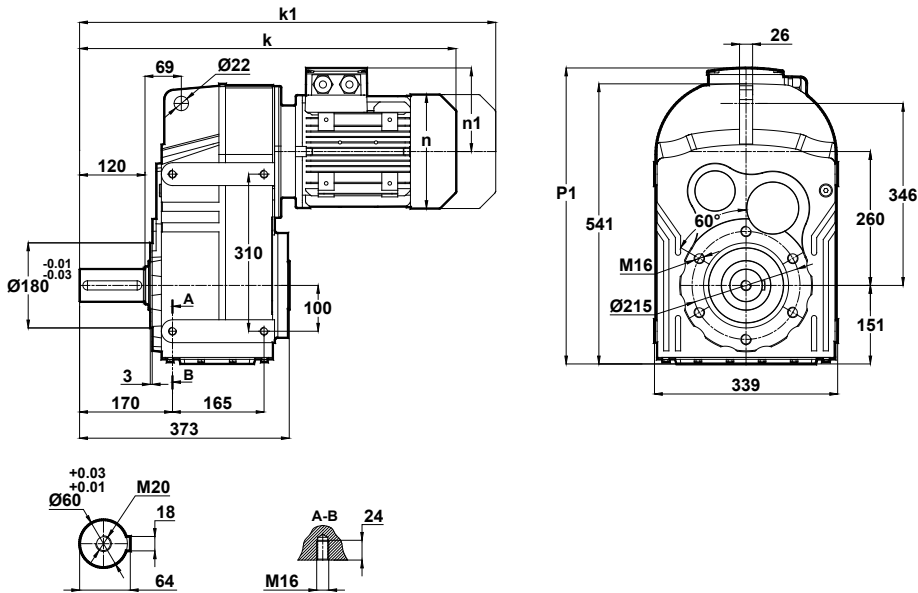

Klemens Pozisyonları  
Terminal Box Positions  
Klemmenkasten Positionen

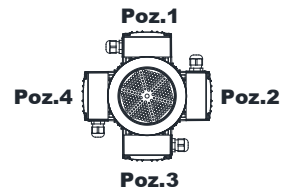

80-90-100-112-132-160-180  
Tip / Type / Typ

	80	90S	90L	100L	112M	132S	132M	160M	160L	180M	180L
k	588	627	627	671	696	781	781	877	877	948	948
k1	681	731.5	731.5	790.5	800.5	911	911	1057	1057	1118.5	1118.5
n	155	176	176	193	215	257	257	315	315	347	347
n1	121	132	132	147	158	179	179	219	219	234	234
p1	-	543	543	558	569	590	590	636	636	655	655

"k1" ölçüsü frenli redüktörlere aittir.  
Dimensions "k1" is for motors with brake.  
Maße "k1" ist für Bremsenmotoren.

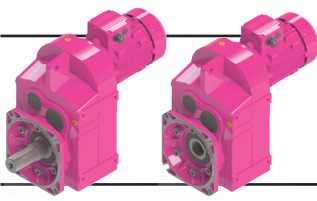

# Ölçü Sayfaları Dimension Pages Abmessungsseiten

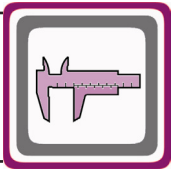

Mil ucu çektirme deliği DIN 332 sayfa 2 / Tapped center hole according to DIN 332, sheet 2 / Zentrierung mit Gewinde nach DIN 332, Blatt 2

DR572.02  
DR573.02

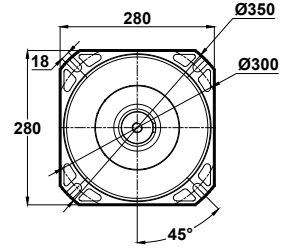
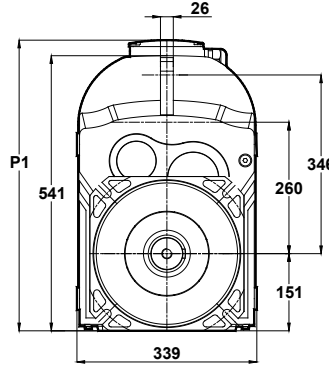
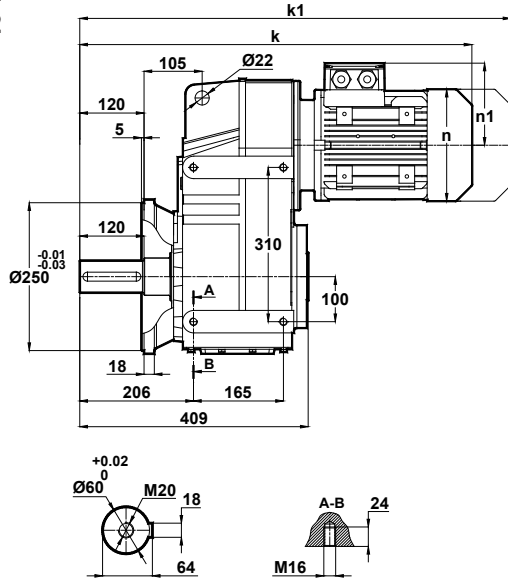

Klemens Pozisyonları  
Terminal Box Positions  
Klemmenkasten Positionen

Opsiyonel Flanş Ölçüleri  
Optional Flange Dimensions  
Auswählbare Flanschabmessungen

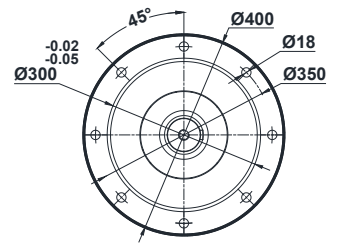
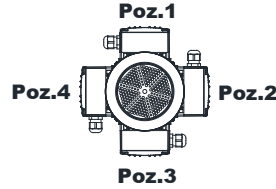

80-90-100-112-132-160-180  
Tip / Type / Typ

	80	90S	90L	100L	112M	132S	132M	160M	160L	180M	180L
k	624	663	663	707	732	817	817	913	913	984	984
k1	717	767.5	767.5	826.5	836.5	947	947	1093	1093	1154.5	1154.5
n	155	176	176	193	215	257	257	315	315	347	347
n1	121	132	132	147	158	179	179	219	219	234	234
p1	-	543	543	558	569	590	590	636	636	655	655

Diğer opsiyonel flanş ölçüleri için sayfa 326'ya bakınız.  
Please see on page 326 for other optional flange dimensions  
Siehe Seite 326 für andere auswählbare Flanschabmessungen

DR572.03  
DR573.03

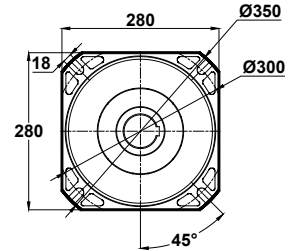
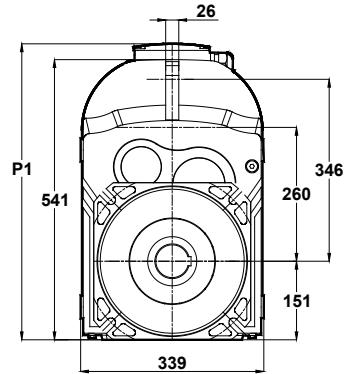
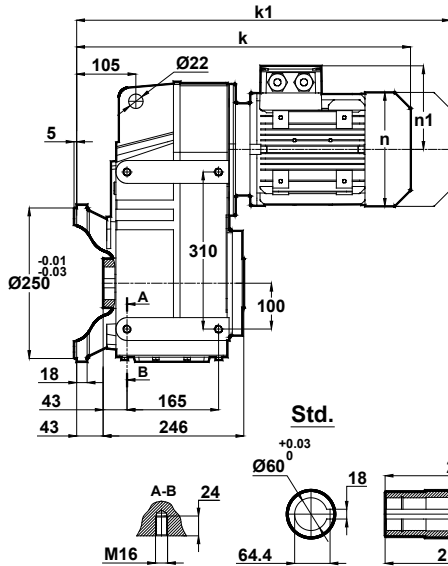

Klemens Pozisyonları  
Terminal Box Positions  
Klemmenkasten Positionen

Opsiyonel Flanş Ölçüleri  
Optional Flange Dimensions  
Auswählbare Flanschabmessungen

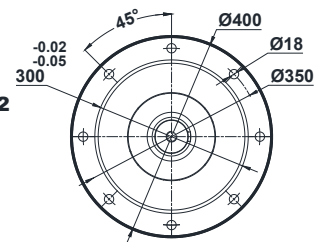
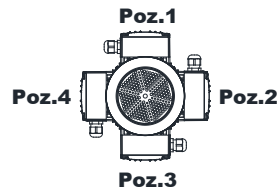

80-90-100-112-132-160-180  
Tip / Type / Typ

	80	90S	90L	100L	112M	132S	132M	160M	160L	180M	180L
k	504	543	543	587	612	697	697	793	793	864	864
k1	597	647.5	647.5	706.5	716.5	827	827	973	973	1034.5	1034.5
n	155	176	176	193	215	257	257	315	315	347	347
n1	121	132	132	147	158	179	179	219	219	234	234
p1	-	543	543	558	569	590	590	636	636	655	655

"k1" ölçüsü frenli redüktörlere aittir.  
Dimensions "k1" is for motors with brake.  
Maße "k1" ist für Bremsenmotoren.

Diğer opsiyonel flanş ölçüleri için sayfa 326'ya bakınız.  
Please see on page 326 for other optional flange dimensions  
Siehe Seite 326 für andere auswählbare Flanschabmessungen

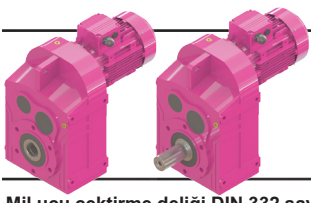

# Ölçü Sayfaları Dimension Pages Abmessungsseiten

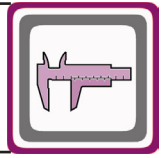

Mil ucu çekirme deliği DIN 332 sayfa 2 / Tapped center hole according to DIN 332, sheet 2 / Zentrierung mit Gewinde nach DIN 332, Blatt 2

DR574.00

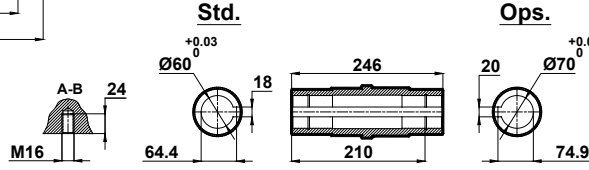
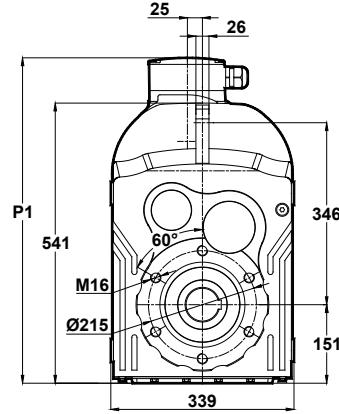
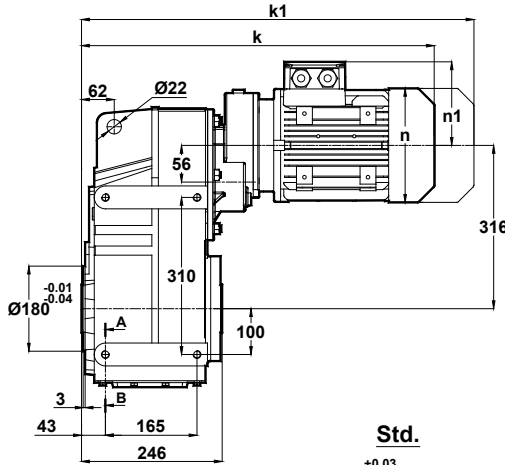

Klemens Pozisyonları  
Terminal Box Positions  
Klemmenkasten Positionen

	71	80	90S	90L
k	520	554	593	593
k1	611	647	697.5	697.5
n	137	155	176	176
n1	112	121	132	132
p1	579	588	599	599

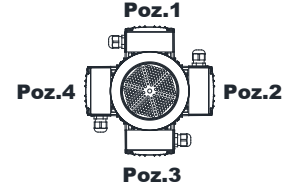

71-80-90  
Tip / Type / Typ

DR574.01

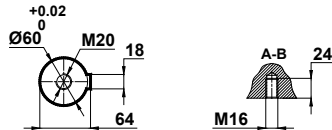
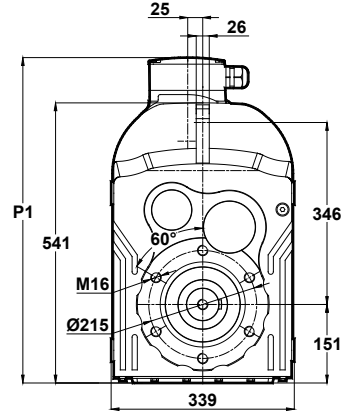
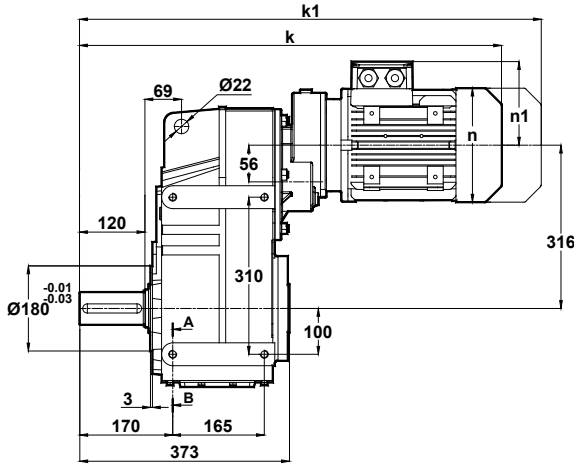

Klemens Pozisyonları  
Terminal Box Positions  
Klemmenkasten Positionen

	71	80	90S	90L
k	647	681	720	720
k1	738	774	824.5	824.5
n	137	155	176	176
n1	112	121	132	132
p1	579	588	599	599

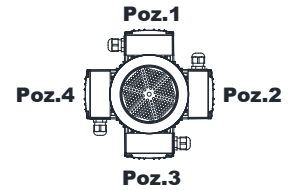

71-80-90  
Tip / Type / Typ

"k1" ölçüsü frenli redüktörlere aittir.  
Dimensions "k1" is for motors with brake.  
Maße "k1" ist für Bremsenmotoren.

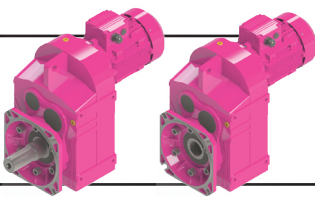

# Ölçü Sayfaları Dimension Pages Abmessungsseiten

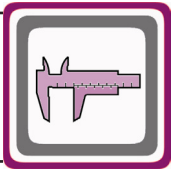

Mil ucu çektirme deliği DIN 332 sayfa 2 / Tapped center hole according to DIN 332, sheet 2 / Zentrierung mit Gewinde nach DIN 332, Blatt 2

## DR574.02

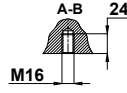
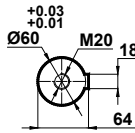
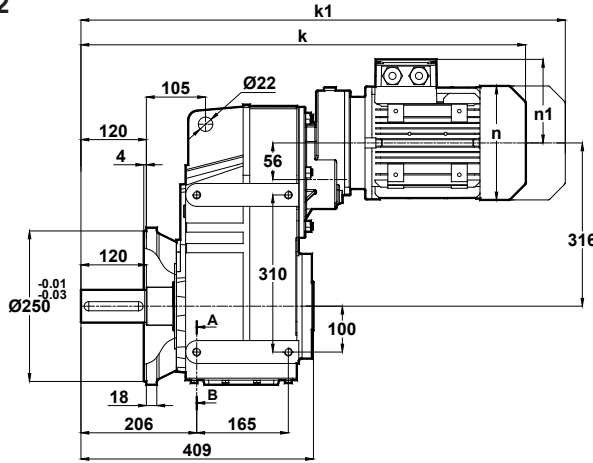

	71	80	90S	90L
k	683	717	756	756
k1	774	810	860.5	860.5
n	137	155	176	176
n1	112	121	132	132
p1	579	588	599	599

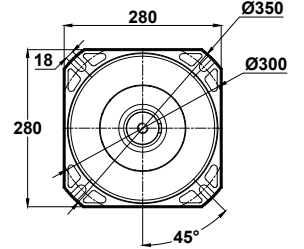
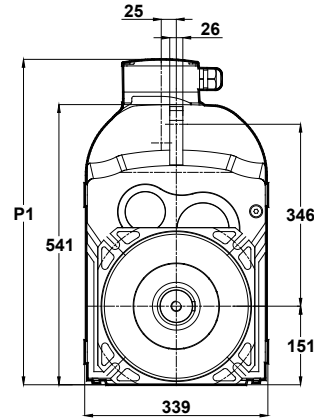

Klemens Pozisyonları  
Terminal Box Positions  
Klemmenkasten Positionen

Opsiyonel Flanş Ölçüleri  
Optional Flange Dimensions  
Auswählbare Flanschabmessungen

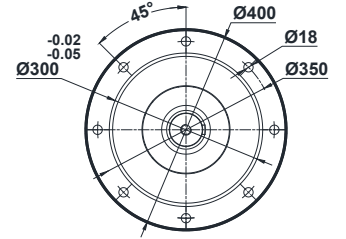
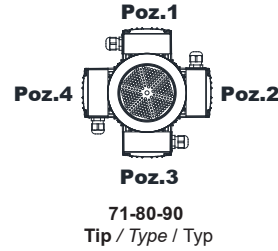

## DR574.03

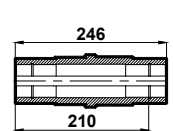
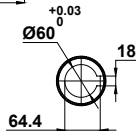
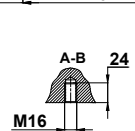
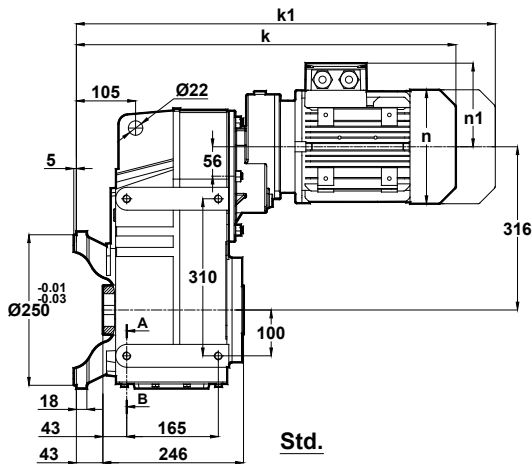

	71	80	90S	90L
k	563	597	636	636
k1	654	690	740.5	740.5
n	137	155	176	176
n1	112	121	132	132
p1	579	588	599	599

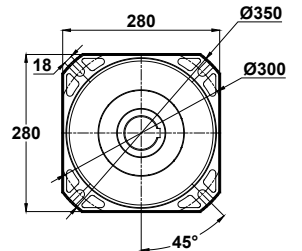
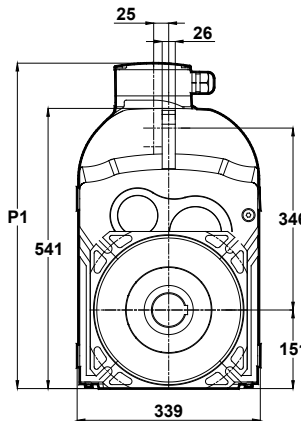

Ops.

Klemens Pozisyonları  
Terminal Box Positions  
Klemmenkasten Positionen

Opsiyonel Flanş Ölçüleri  
Optional Flange Dimensions  
Auswählbare Flanschabmessungen

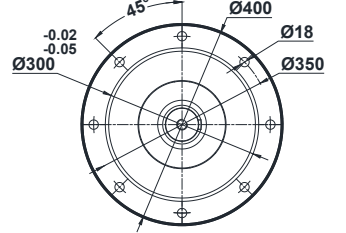
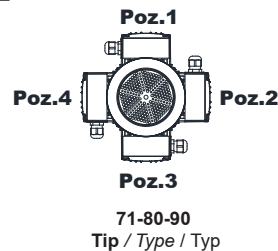

"k1" ölçüsü frenli redüktörlere aittir.  
Dimensions "k1" is for motors with brake.  
Maße "k1" ist für Bremsenmotoren.

Diğer opsiyonel flanş ölçüleri için sayfa 326'ya bakınız.  
Please see on page 326 for other optional flange dimensions  
Siehe Seite 326 für andere auswählbare Flanschabmessungen

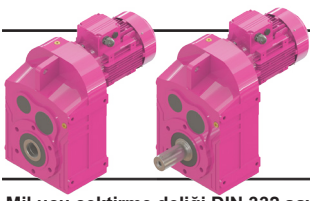

# Ölçü Sayfaları Dimension Pages Abmessungsseiten

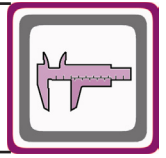

Mil ucu çekirtme deliği DIN 332 sayfa 2 / Tapped center hole according to DIN 332, sheet 2 / Zentrierung mit Gewinde nach DIN 332, Blatt 2

DR575.00  
DR576.00

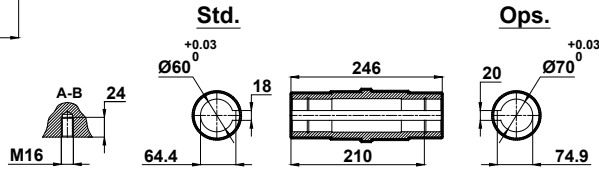
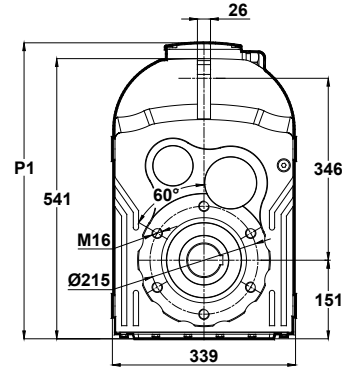
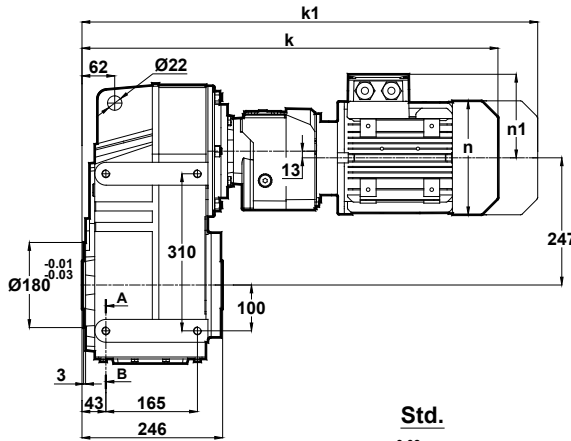

Klemens Pozisyonları  
Terminal Box Positions  
Klemmenkasten Positionen

	63	71
k	622	650
k1	683	741
n	121	137
n1	97	112
p1	-	-

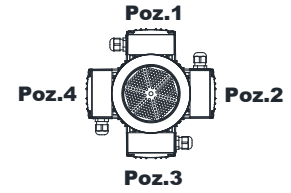

63-71  
Tip / Type / Typ

DR575.01  
DR576.01

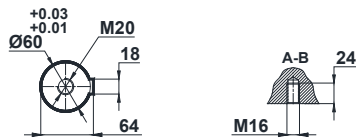
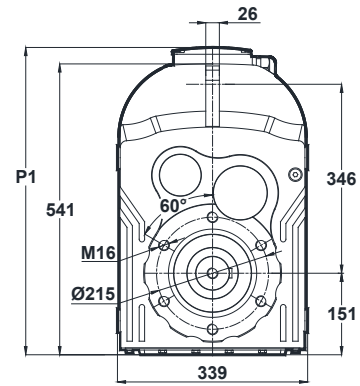
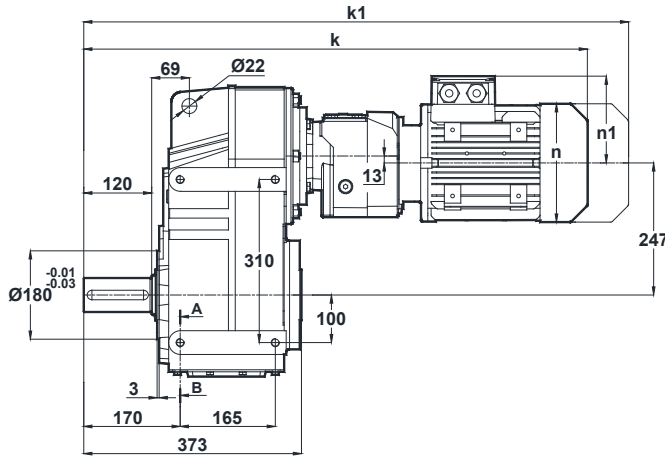

Klemens Pozisyonları  
Terminal Box Positions  
Klemmenkasten Positionen

	63	71
k	749	777
k1	810	868
n	121	137
n1	97	112
p1	-	-

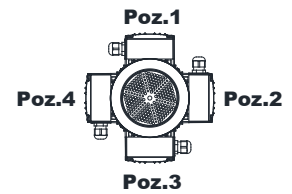

63-71  
Tip / Type / Typ

"k1" ölçüsü frenli redüktörlere aittir.  
Dimensions "k1" is for motors with brake.  
Maße "k1" ist für Bremsenmotoren.

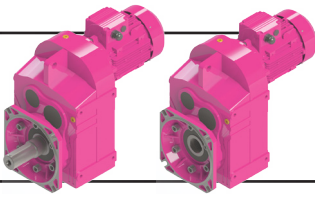

# Ölçü Sayfaları Dimension Pages Abmessungsseiten

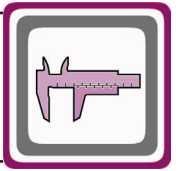

Mil ucu çektirme deliği DIN 332 sayfa 2 / Tapped center hole according to DIN 332, sheet 2 / Zentrierung mit Gewinde nach DIN 332, Blatt 2

DR575.02  
DR576.02

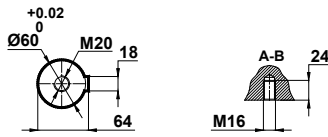
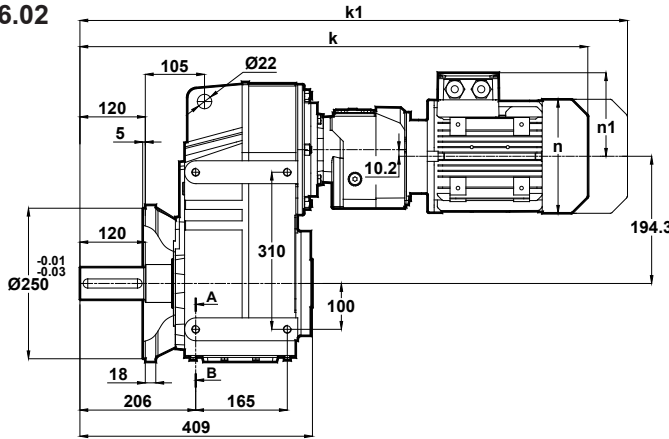

	63	71
k	785	813
k1	846	904
n	121	137
n1	97	112
p1	-	-

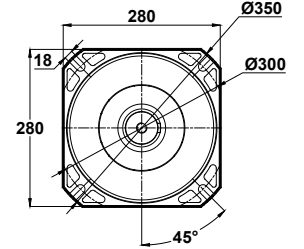
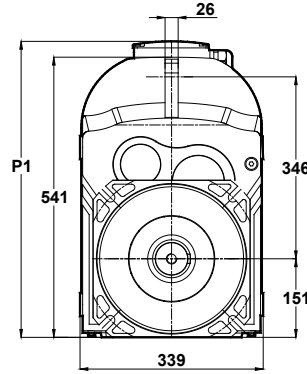

Klemens Pozisyonları  
Terminal Box Positions  
Klemmenkasten Positionen

Opsiyonel Flanş Ölçüleri  
Optional Flange Dimensions  
Auswählbare Flanschabmessungen

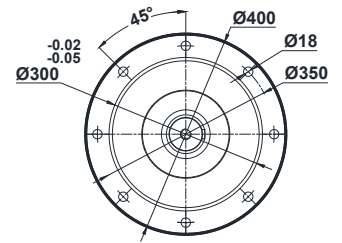
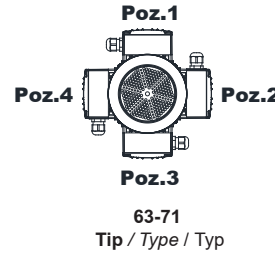

63-71

Tip / Type / Typ

Diğer opsiyonel flanş ölçüleri için sayfa 326'ya bakınız.  
Please see on page 326 for other optional flange dimensions  
Siehe Seite 326 für andere auswählbare Flanschabmessungen

DR575.03  
DR576.03

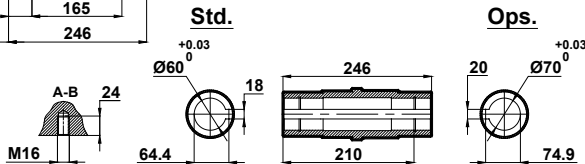
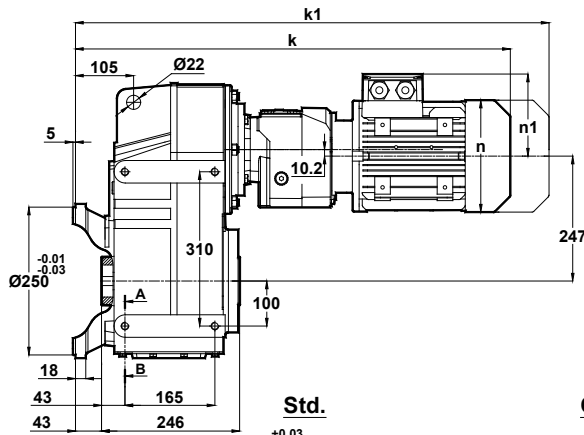

	63	71
k	665	693
k1	726	784
n	121	137
n1	97	112
p1	-	-

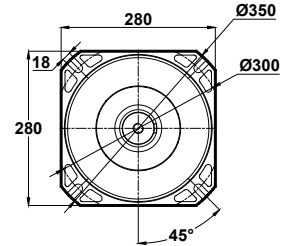
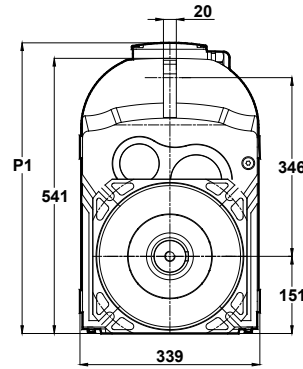

Klemens Pozisyonları  
Terminal Box Positions  
Klemmenkasten Positionen

Opsiyonel Flanş Ölçüleri  
Optional Flange Dimensions  
Auswählbare Flanschabmessungen

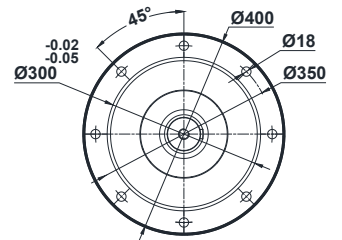
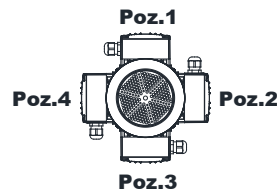

63-71

Tip / Type / Typ

Diğer opsiyonel flanş ölçüleri için sayfa 326'ya bakınız.  
Please see on page 326 for other optional flange dimensions  
Siehe Seite 326 für andere auswählbare Flanschabmessungen

"k1" ölçüsü frenli redüktörlere aittir.  
Dimensions "k1" is for motors with brake.  
Maße "k1" ist für Bremsenmotoren.

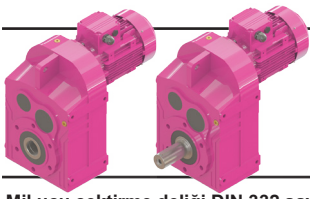

# Ölçü Sayfaları Dimension Pages Abmessungsseiten

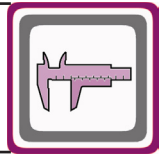

Mil ucu çektirme deliği DIN 332 sayfa 2 / Tapped center hole according to DIN 332, sheet 2 / Zentrierung mit Gewinde nach DIN 332, Blatt 2

DR672.00  
DR673.00

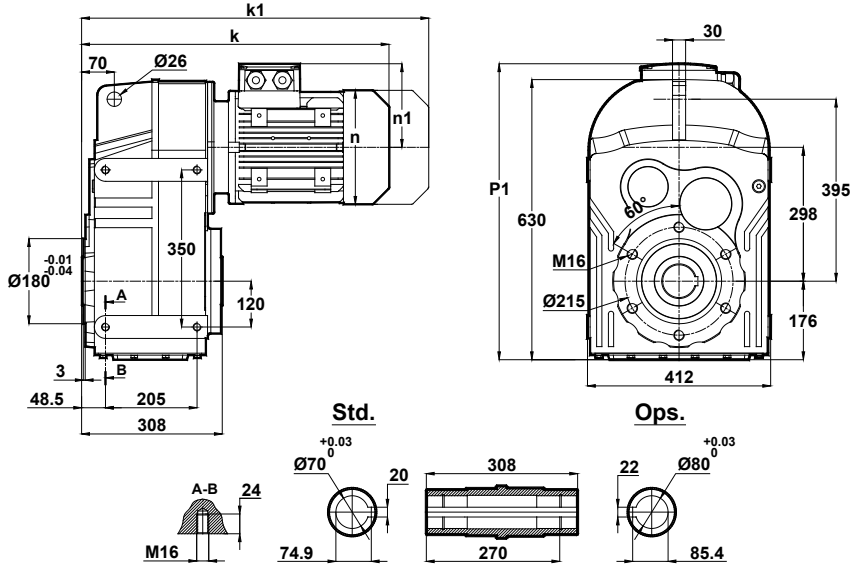

	100L	112M	132S	132M	160M	160L	180M	180L	200L
k	593	617	704	704	800	800	871	871	913
k1	712.5	721.5	834	834	980	980	1041.5	1041.5	1099.5
n	193	215	257	257	315	315	347	347	390
n1	147	158	179	179	219	219	234	234	275
p1	-	632	653	653	699	699	718	718	749

Klemens Pozisyonları  
Terminal Box Positions  
Klemmenkasten Positionen

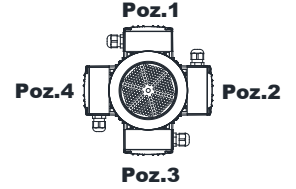

100-112-132-160-180-200  
Tip / Type / Typ

DR672.01  
DR673.01

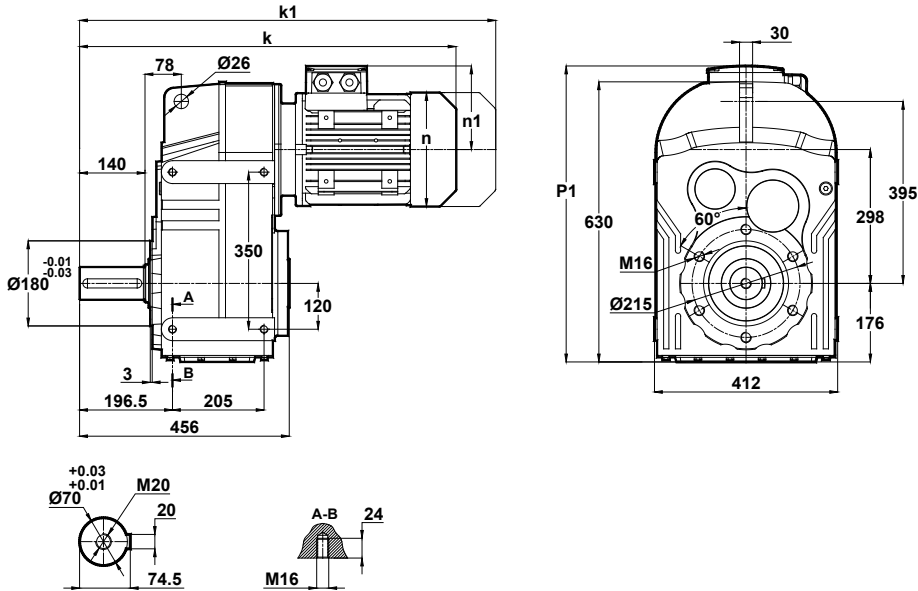

	100L	112M	132S	132M	160M	160L	180M	180L	200L
k	741	765	852	852	948	948	1019	1019	1061
k1	860.5	869.5	982	982	1128	1128	1189.5	1189.5	1247.5
n	193	215	257	257	315	315	347	347	390
n1	147	158	179	179	219	219	234	234	275
p1	-	632	653	653	699	699	718	718	749

Klemens Pozisyonları  
Terminal Box Positions  
Klemmenkasten Positionen

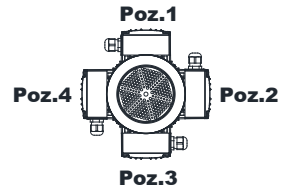

100-112-132-160-180-200  
Tip / Type / Typ

"k1" ölçüsü frenli redüktörlere aittir.  
Dimensions "k1" is for motors with brake.  
Maße "k1" ist für Bremsenmotoren.

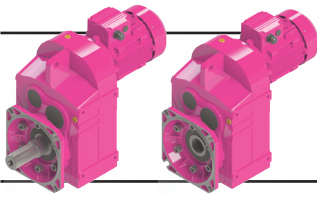

# Ölçü Sayfaları Dimension Pages Abmessungsseiten

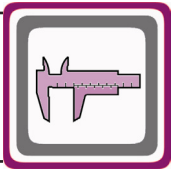

Mil ucu çektirme deliği DIN 332 sayfa 2 / Tapped center hole according to DIN 332, sheet 2 / Zentrierung mit Gewinde nach DIN 332, Blatt 2

DR672.02  
DR673.02

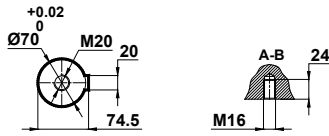
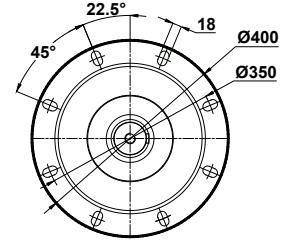
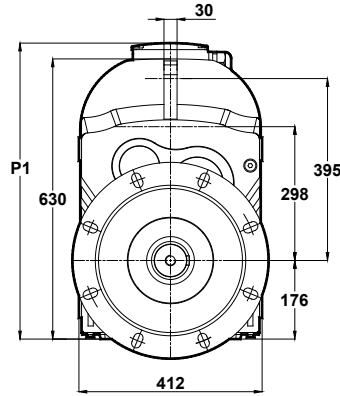
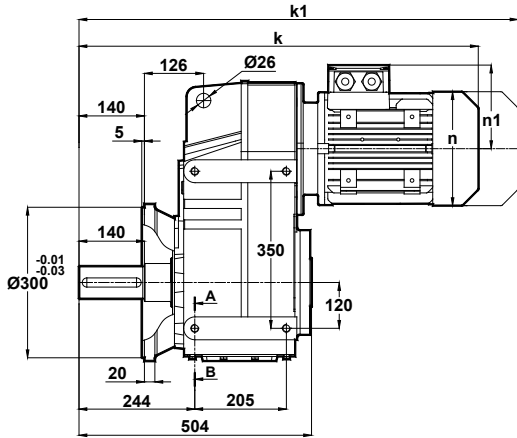

Klemens Pozisyonları  
Terminal Box Positions  
Klemmenkasten Positionen

Opsiyonel Flaş Ölçüleri  
Optional Flange Dimensions  
Auswählbare Flanschabmessungen

	100L	112M	132S	132M	160M	160L	180M	180L	200L
k	789	813	900	900	996	996	1067	1067	1109
k1	908.5	917.5	1030	1030	1176	1176	1237.5	1237.5	1295.5
n	193	215	257	257	315	315	347	347	390
n1	147	158	179	179	219	219	234	234	275
p1	-	632	653	653	699	699	718	718	749

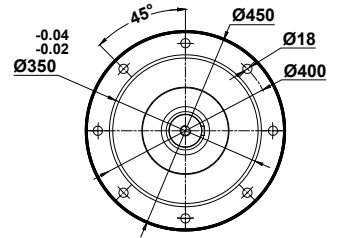
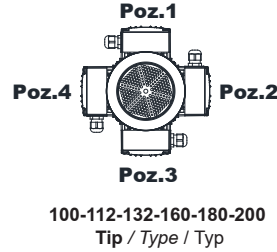

Diğer opsiyonel flaş ölçüleri için sayfa 326'ya bakınız.  
Please see on page 326 for other optional flange dimensions  
Siehe Seite 326 für andere auswählbare Flanschabmessungen

DR672.03  
DR673.03

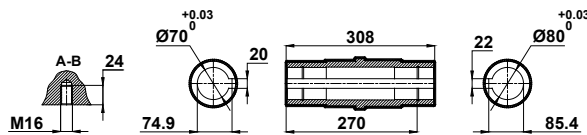
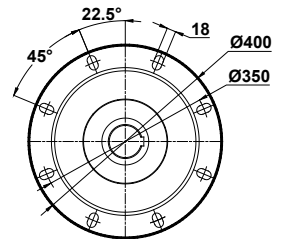
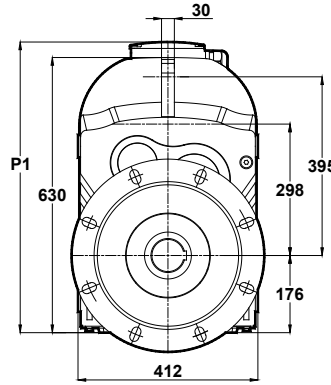
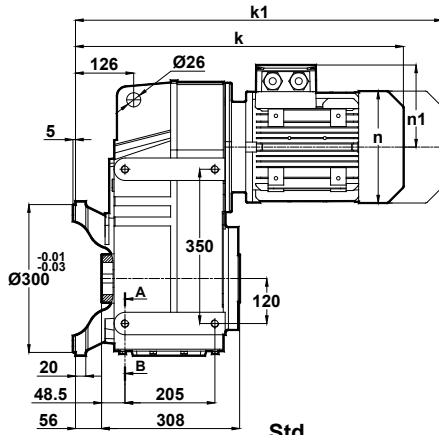

Klemens Pozisyonları  
Terminal Box Positions  
Klemmenkasten Positionen

Opsiyonel Flaş Ölçüleri  
Optional Flange Dimensions  
Auswählbare Flanschabmessungen

	100L	112M	132S	132M	160M	160L	180M	180L	200L
k	649	673	760	760	856	856	927	927	969
k1	768.5	777.5	890	890	1036	1036	1097.5	1097.5	1155.5
n	193	215	257	257	315	315	347	347	390
n1	147	158	179	179	219	219	234	234	275
p1	-	632	653	653	699	699	718	718	749

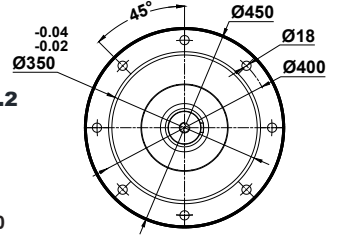
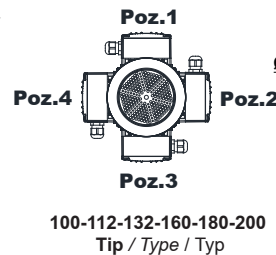

Diğer opsiyonel flaş ölçüleri için sayfa 326'ya bakınız.  
Please see on page 326 for other optional flange dimensions  
Siehe Seite 326 für andere auswählbare Flanschabmessungen

"k1" ölçüsü frenli redüktörlere aittir.  
Dimensions "k1" is for motors with brake.  
Maße "k1" ist für Bremsenmotoren.

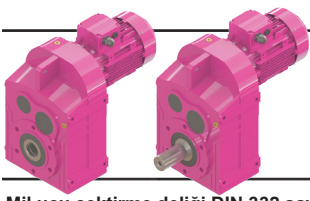

# Ölçü Sayfaları Dimension Pages Abmessungsseiten

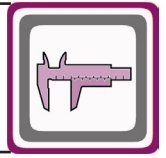

Mil ucu çektirme deliği DIN 332 sayfa 2 / Tapped center hole according to DIN 332, sheet 2 / Zentrierung mit Gewinde nach DIN 332, Blatt 2

DR674.00

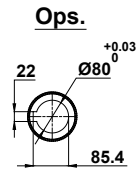
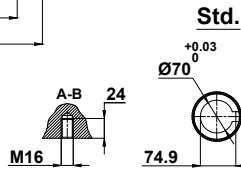
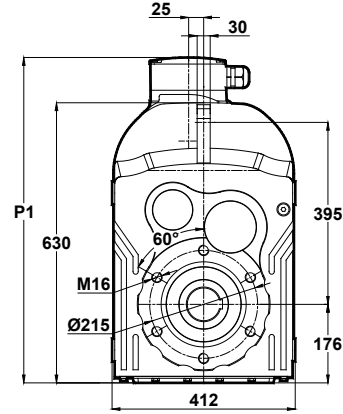
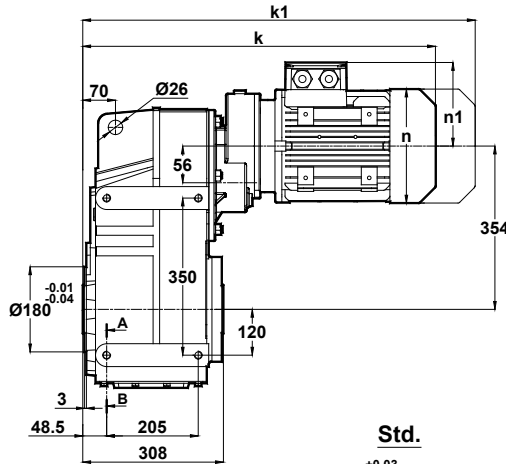

Klemens Pozisyonları  
Terminal Box Positions  
Klemmenkasten Positionen

	71	80	90S	90L
k	573	607	646	646
k1	664	700	750.5	750.5
n	137	155	176	176
n1	112	121	132	132
p1	642	651	662	662

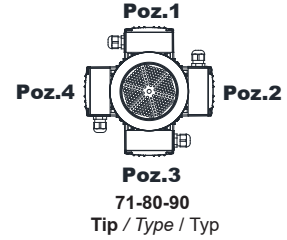

DR674.01

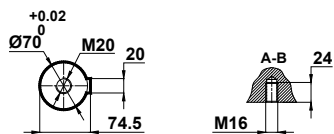
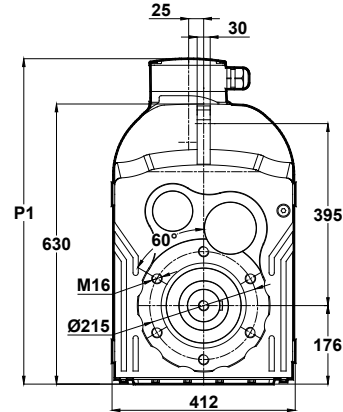
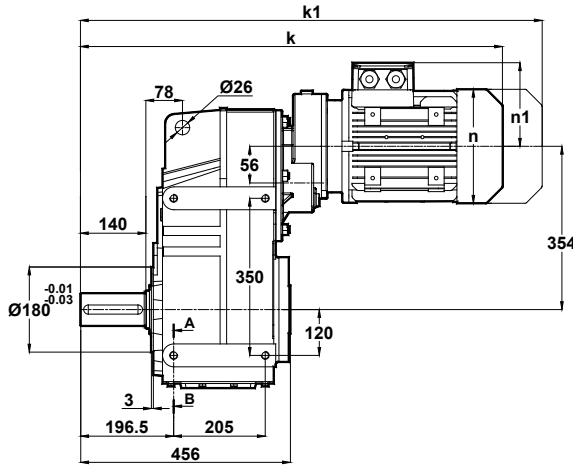

Klemens Pozisyonları  
Terminal Box Positions  
Klemmenkasten Positionen

	71	80	90S	90L
k	721	755	794	794
k1	812	848	898.5	898.5
n	137	155	176	176
n1	112	121	132	132
p1	642	651	662	662

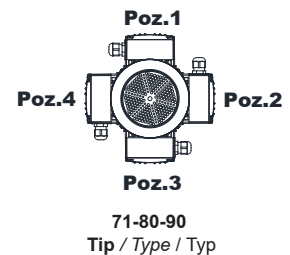

"k1" ölçüsü frenli redüktörlere aittir.  
Dimensions "k1" is for motors with brake.  
Maße "k1" ist für Bremsenmotoren.

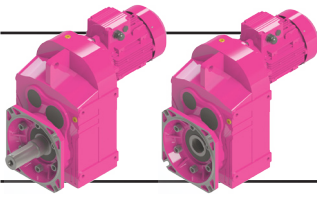

# Ölçü Sayfaları Dimension Pages Abmessungsseiten

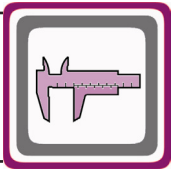

Mil ucu çektirme deliği DIN 332 sayfa 2 / Tapped center hole according to DIN 332, sheet 2 / Zentrierung mit Gewinde nach DIN 332, Blatt 2

## DR674.02

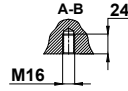
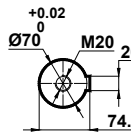
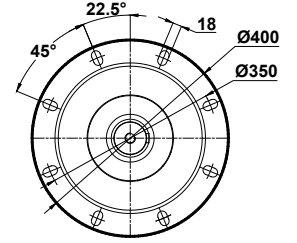
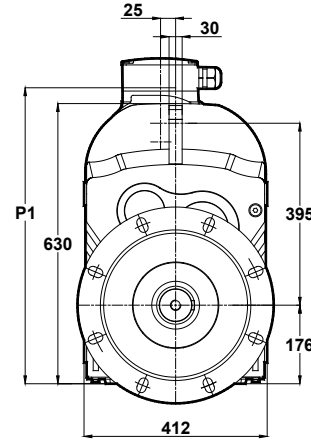
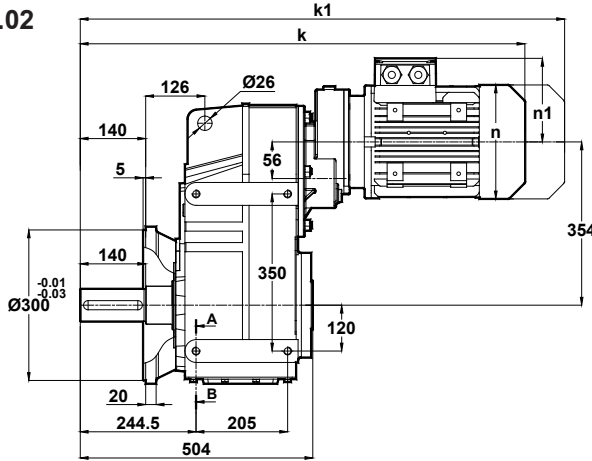

Klemens Pozisyonları  
Terminal Box Positions  
Klemmenkasten Positionen

Opsiyonel Flanş Ölçüleri  
Optional Flange Dimensions  
Auswählbare Flanschabmessungen

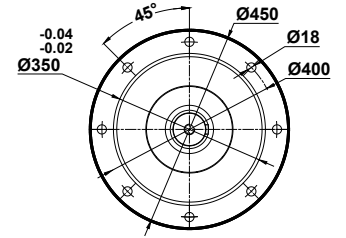
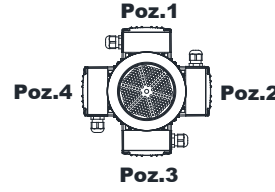

	71	80	90S	90L
k	769	803	842	842
k1	860	896	946.5	946.5
n	137	155	176	176
n1	112	121	132	132
p1	642	651	662	662

71-80-90  
Tip / Type / Typ

Diğer opsiyonel flanş ölçüleri için sayfa 326'ya bakınız.  
Please see on page 326 for other optional flange dimensions  
Siehe Seite 326 für andere auswählbare Flanschabmessungen

## DR674.03

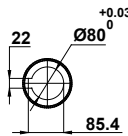
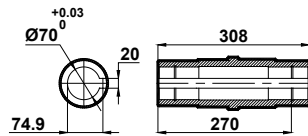
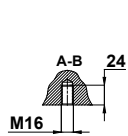
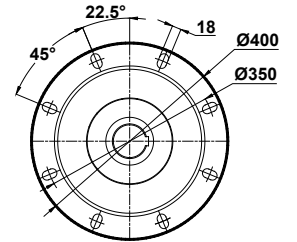
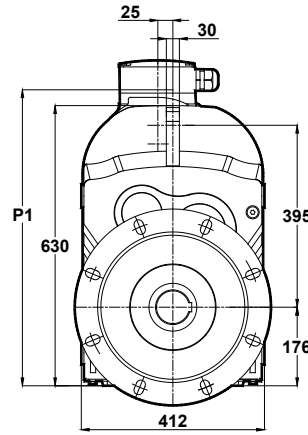
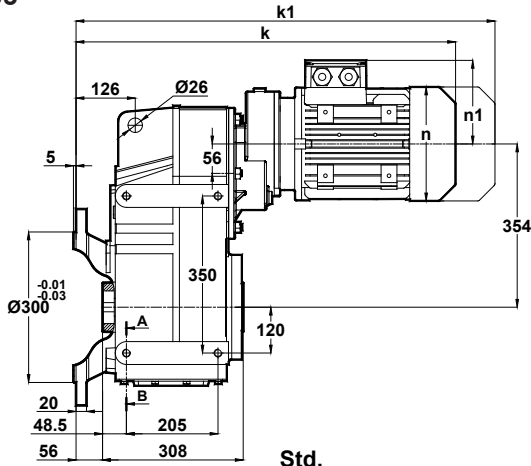

Klemens Pozisyonları  
Terminal Box Positions  
Klemmenkasten Positionen

Opsiyonel Flanş Ölçüleri  
Optional Flange Dimensions  
Auswählbare Flanschabmessungen

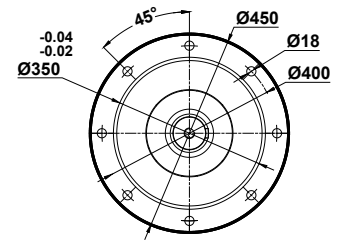
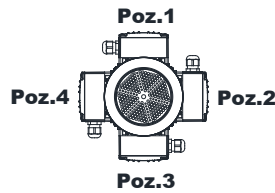

	71	80	90S	90L
k	629	663	702	702
k1	720	756	806.5	806.5
n	137	155	176	176
n1	112	121	132	132
p1	642	651	662	662

71-80-90  
Tip / Type / Typ

"k1" ölçüsü frenli redüktörlere aittir.  
Dimensions "k1" is for motors with brake.  
Maße "k1" ist für Bremsenmotoren.

Diğer opsiyonel flanş ölçüleri için sayfa 326'ya bakınız.  
Please see on page 326 for other optional flange dimensions  
Siehe Seite 326 für andere auswählbare Flanschabmessungen

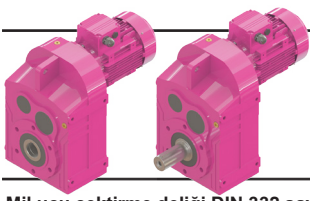

# Ölçü Sayfaları Dimension Pages Abmessungsseiten

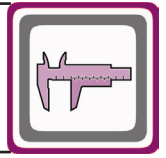

Mil ucu çektirme deliği DIN 332 sayfa 2 / Tapped center hole according to DIN 332, sheet 2 / Zentrierung mit Gewinde nach DIN 332, Blatt 2

DR675.00  
DR676.00

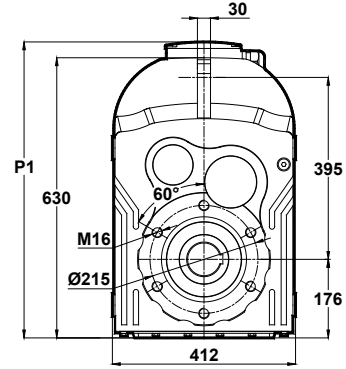
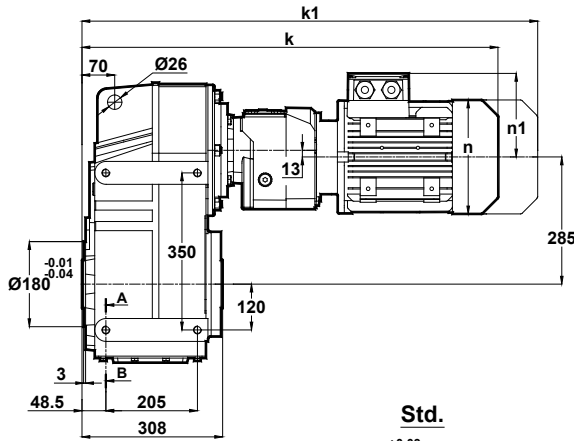

Std.

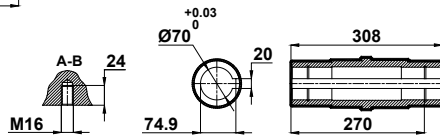

Ops.

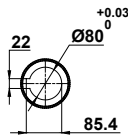

Klemens Pozisyonları  
Terminal Box Positions  
Klemmenkasten Positionen

	63	71	80
k	677	705	739
k1	738	796	832
n	121	137	155
n1	97	112	121
p1	-	-	-

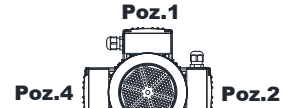

Poz.1

63-71-80

Tip / Type / Typ

DR675.01  
DR676.01

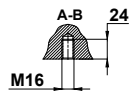
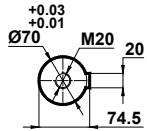
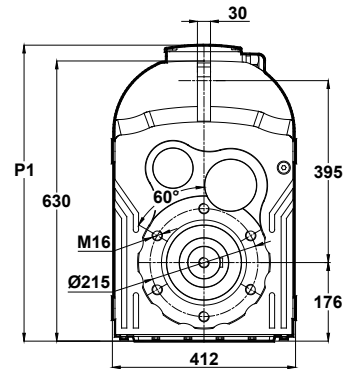
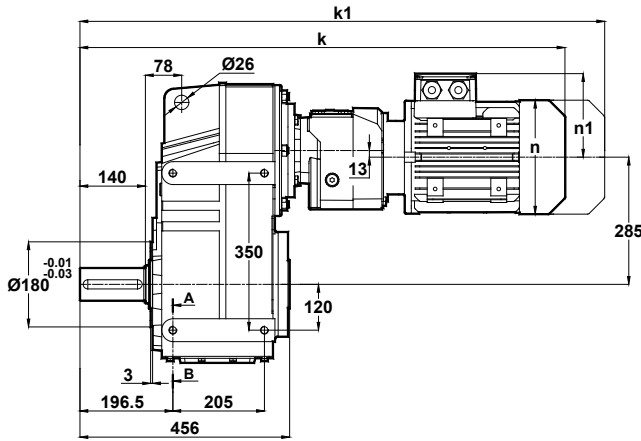

Klemens Pozisyonları  
Terminal Box Positions  
Klemmenkasten Positionen

	63	71	80
k	825	853	887
k1	886	944	980
n	121	137	155
n1	97	112	121
p1	-	-	-

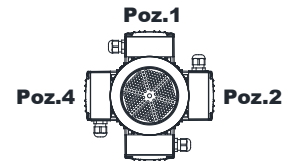

Poz.1

63-71-80

Tip / Type / Typ

"k1" ölçüsü frenli redüktörlere aittir.  
Dimensions "k1" is for motors with brake.  
Maße "k1" ist für Bremsenmotoren.

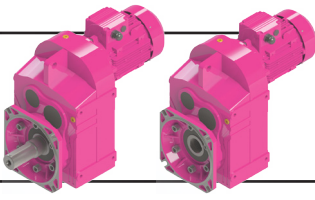

# Ölçü Sayfaları Dimension Pages Abmessungsseiten

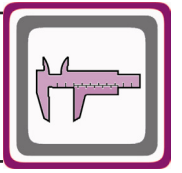

Mil ucu çektirme deliği DIN 332 sayfa 2 / Tapped center hole according to DIN 332, sheet 2 / Zentrierung mit Gewinde nach DIN 332, Blatt 2

DR675.02  
DR676.02

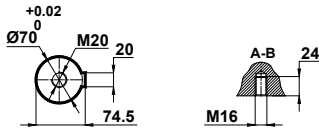
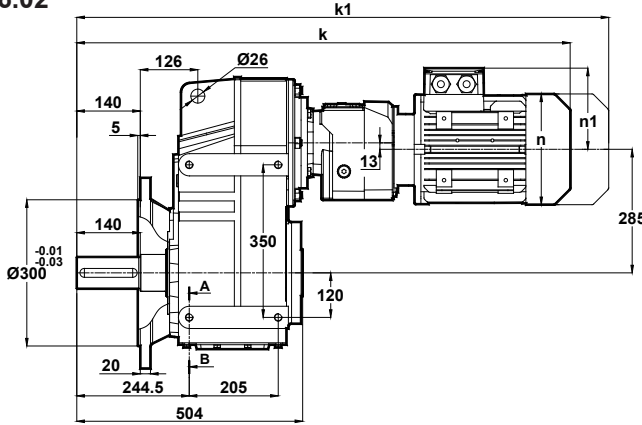

	63	71	80
k	873	901	935
k1	934	992	1028
n	121	137	155
n1	97	112	121
p1	-	-	-

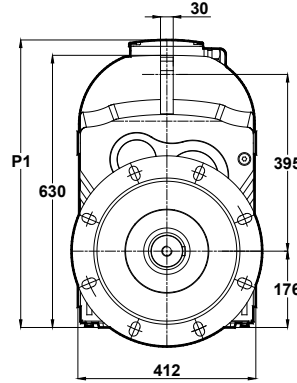

Klemens Pozisyonları  
Terminal Box Positions  
Klemmenkasten Positionen

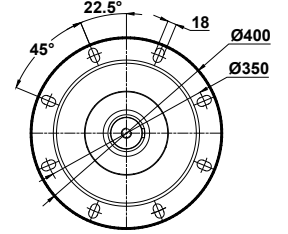

Opsiyonel Flaş Ölçüleri  
Optional Flange Dimensions  
Auswählbare Flanschabmessungen

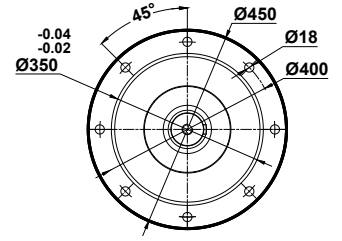
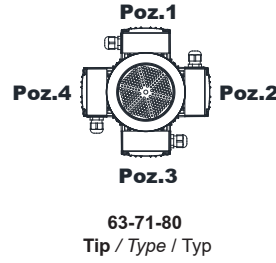

63-71-80  
Tip / Type / Typ

DR675.03  
DR676.03

Diğer opsiyonel flaş ölçüleri için sayfa 326'ya bakınız.  
Please see on page 326 for other optional flange dimensions  
Siehe Seite 326 für andere auswählbare Flanschabmessungen

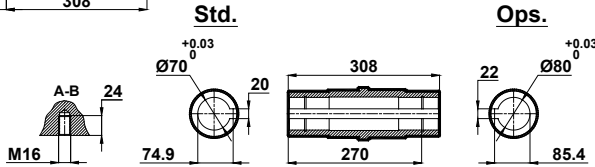
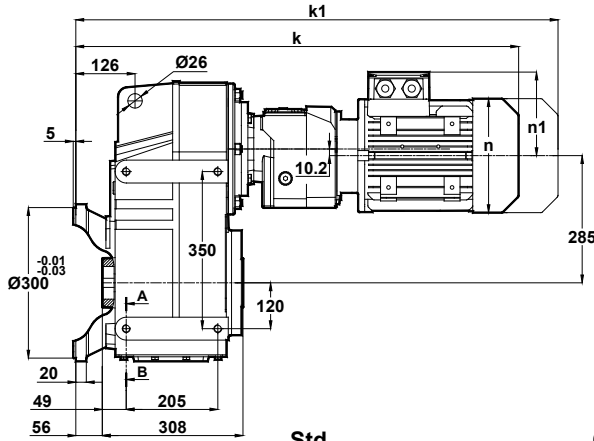

	63	71	80
k	733	761	795
k1	794	852	888
n	121	137	155
n1	97	112	121
p1	-	-	-

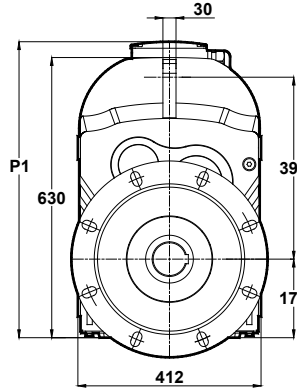

Klemens Pozisyonları  
Terminal Box Positions  
Klemmenkasten Positionen

Opsiyonel Flaş Ölçüleri  
Optional Flange Dimensions  
Auswählbare Flanschabmessungen

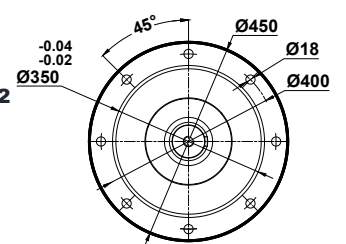
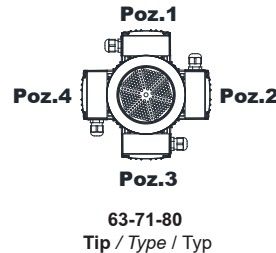

63-71-80  
Tip / Type / Typ

"k1" ölçüsü frenli redüktörlere aittir.  
Dimensions "k1" is for motors with brake.  
Maße "k1" ist für Bremsenmotoren.

Diğer opsiyonel flaş ölçüleri için sayfa 326'ya bakınız.  
Please see on page 326 for other optional flange dimensions  
Siehe Seite 326 für andere auswählbare Flanschabmessungen

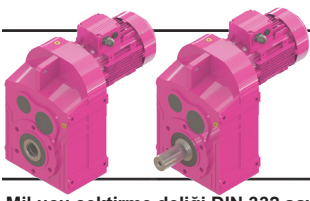

# Ölçü Sayfaları Dimension Pages Abmessungsseiten

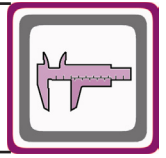

Mil ucu çektirme deliği DIN 332 sayfa 2 / Tapped center hole according to DIN 332, sheet 2 / Zentrierung mit Gewinde nach DIN 332, Blatt 2

DR772.00  
DR773.00

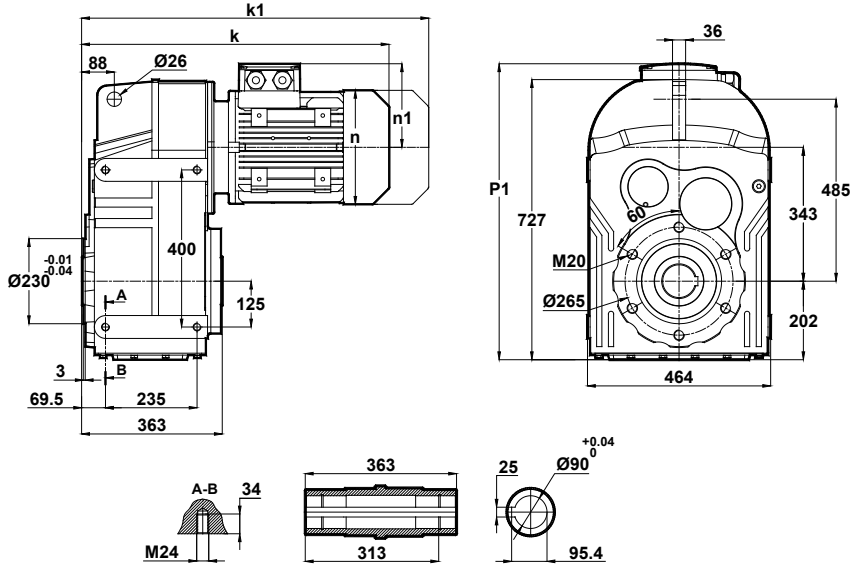

Klemens Pozisyonları  
Terminal Box Positions  
Klemmenkasten Positionen

	100L	112M	132S	132M	160M	160L	180M	180L	200L	225S	225M
k	585	655	742	742	838	838	909	909	951	977	1002
k1	704.5	759.5	872	872	1018	1018	1079.5	1079.5	1137.5	1142	1167
n	193	215	257	257	315	315	347	347	390	434	434
n1	147	158	179	179	219	219	234	234	275	285	285
p1	-	-	724	724	770	770	789	789	820	830	830

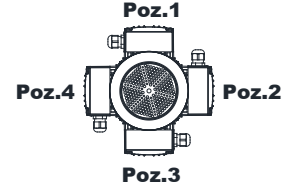

100-112-132-160-180-200-225  
Tip / Type / Typ

DR772.01  
DR773.01

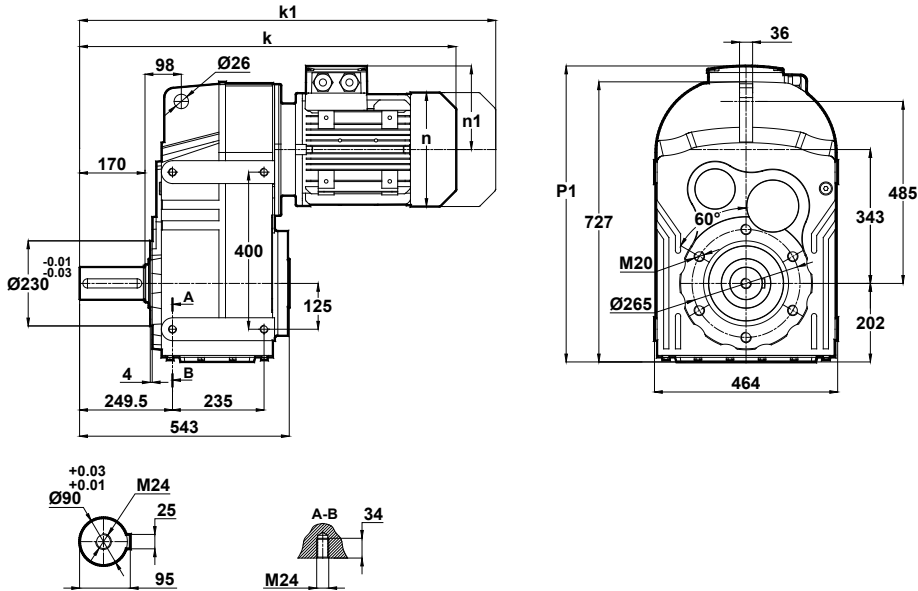

Klemens Pozisyonları  
Terminal Box Positions  
Klemmenkasten Positionen

	100L	112M	132S	132M	160M	160L	180M	180L	200L	225S	225M
k	733	835	922	922	1018	1018	1089	1089	1131	1157	1182
k1	852.5	939.5	1052	1052	1198	1198	1259.5	1259.5	1317.5	1322	1347
n	193	215	257	257	315	315	347	347	390	434	434
n1	147	158	179	179	219	219	234	234	275	285	285
p1	-	-	724	724	770	770	789	789	820	830	830

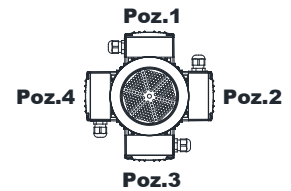

100-112-132-160-180-200-225  
Tip / Type / Typ

"k1" ölçüsü frenli redüktörlere aittir.  
Dimensions "k1" is for motors with brake.  
Maße "k1" ist für Bremsenmotoren.

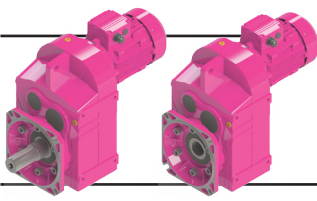

# Ölçü Sayfaları Dimension Pages Abmessungsseiten

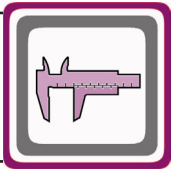

Mil ucu çektirme deliği DIN 332 sayfa 2 / Tapped center hole according to DIN 332, sheet 2 / Zentrierung mit Gewinde nach DIN 332, Blatt 2

DR772.02  
DR773.02

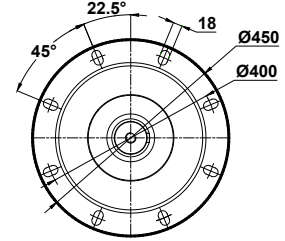
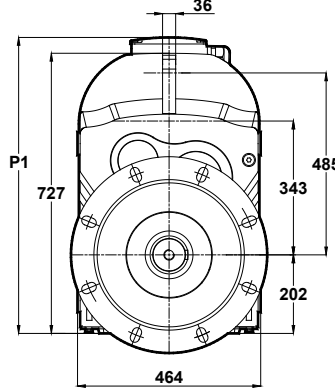
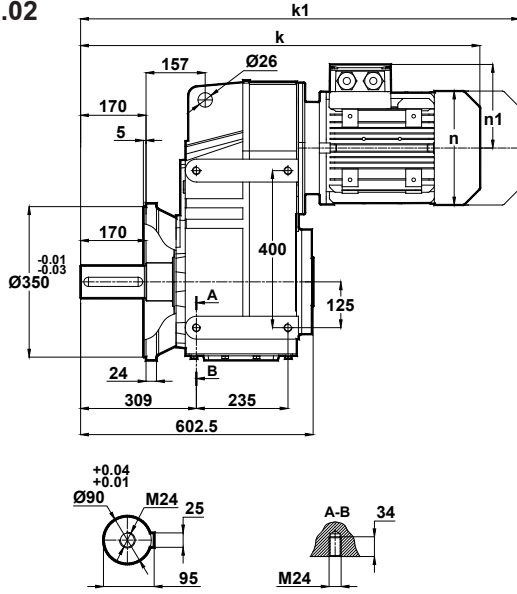

Klemens Pozisyonları  
Terminal Box Positions  
Klemmenkasten Positionen

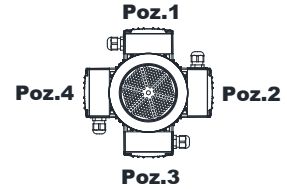

100-112-132-160-180-200-225  
Tip / Type / Typ

Opsiyonel flanş ölçüleri için sayfa 326'ya bakınız.  
Please see on page 326 for optional flange dimensions  
Siehe Seite 326 für auswählbare Flanschabmessungen

	100L	112M	132S	132M	160M	160L	180M	180L	200L	225S	225M
k	781	895	982	982	1078	1078	1149	1149	1191	1217	1242
k1	900.5	999.5	1112	1112	1258	1258	1319.5	1319.5	1377.5	1382	1407
n	193	215	257	257	315	315	347	347	390	434	434
n1	147	158	179	179	219	219	234	234	275	285	285
p1	-	-	724	724	770	770	789	789	820	830	830

DR772.03  
DR773.03

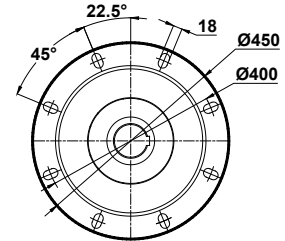
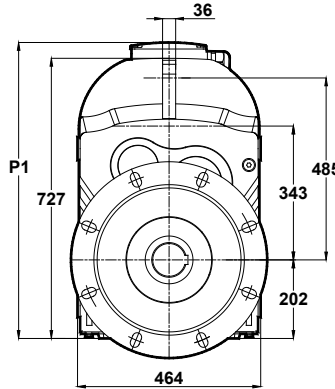
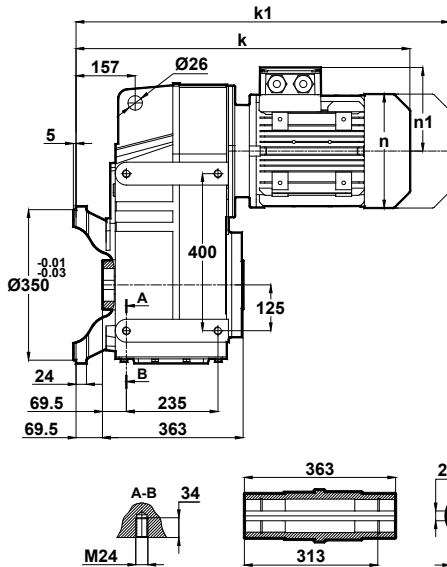

Klemens Pozisyonları  
Terminal Box Positions  
Klemmenkasten Positionen

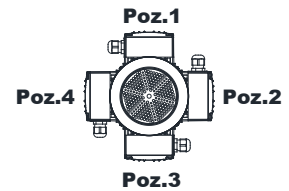

100-112-132-160-180-200-225  
Tip / Type / Typ

Opsiyonel flanş ölçüleri için sayfa 326'ya bakınız.  
Please see on page 326 for optional flange dimensions  
Siehe Seite 326 für auswählbare Flanschabmessungen

	100L	112M	132S	132M	160M	160L	180M	180L	200L	225S	225M
k	641	725	812	812	908	908	979	979	1021	1047	1072
k1	760.5	829.5	942	942	1088	1088	1149.5	1149.5	1207.5	1212	1237
n	193	215	257	257	315	315	347	347	390	434	434
n1	147	158	179	179	219	219	234	234	275	285	285
p1	-	-	724	724	770	770	789	789	820	830	830

"k1" ölçüsü frenli redüktörlere aittir.  
Dimensions "k1" is for motors with brake.  
Maße "k1" ist für Bremsenmotoren.

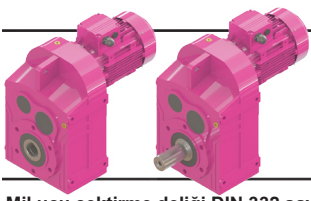

# Ölçü Sayfaları Dimension Pages Abmessungsseiten

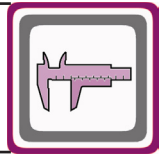

Mil ucu çektirme deliği DIN 332 sayfa 2 / Tapped center hole according to DIN 332, sheet 2 / Zentrierung mit Gewinde nach DIN 332, Blatt 2

DR774.00

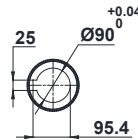
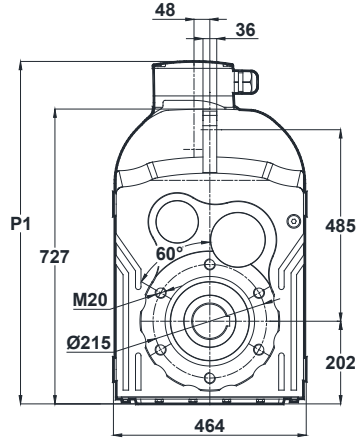
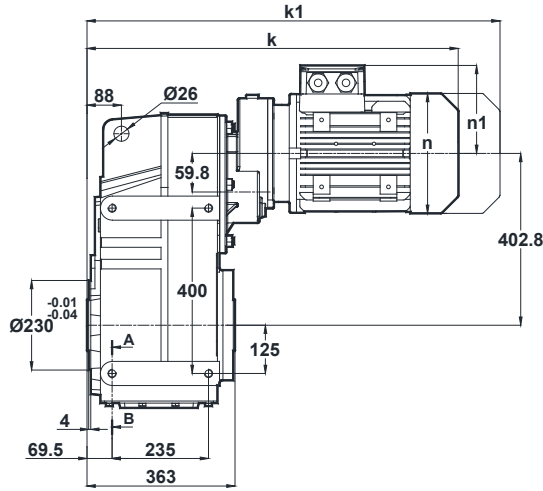

Klemens Pozisyonları  
Terminal Box Positions  
Klemmenkasten Positionen

	80	90S	90L	100L
k	664	703	703	747
k1	757	807.5	807.5	866.5
n	155	176	176	193
n1	121	132	132	147
p1	-	737	737	752

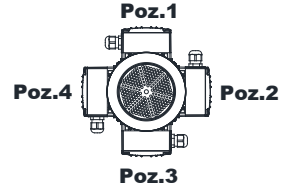

80-90-100  
Tip / Type / Typ

DR774.01

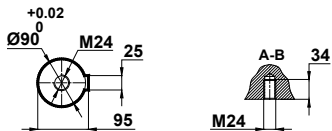
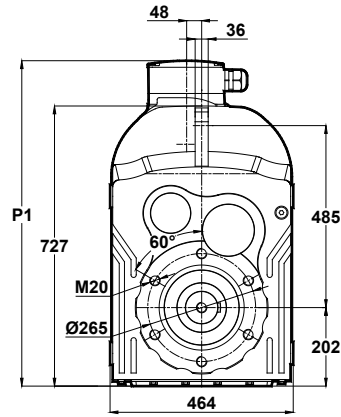
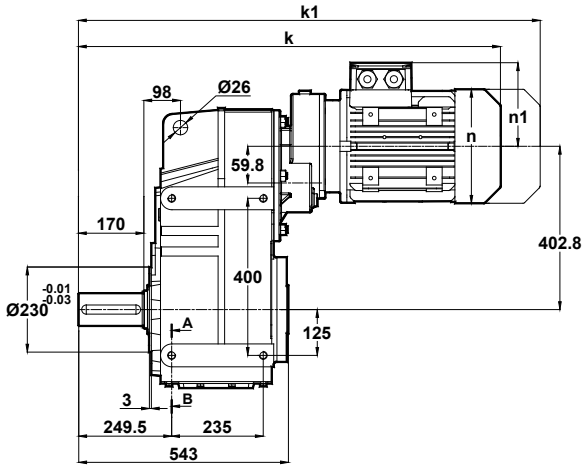

Klemens Pozisyonları  
Terminal Box Positions  
Klemmenkasten Positionen

	80	90S	90L	100L
k	844	883	883	927
k1	937	987.5	987.5	1046.5
n	155	176	176	193
n1	121	132	132	147
p1	-	737	737	752

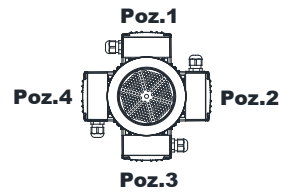

80-90-100  
Tip / Type / Typ

"k1" ölçüsü frenli redüktörlere aittir.  
Dimensions "k1" is for motors with brake.  
Maße "k1" ist für Bremsenmotoren.

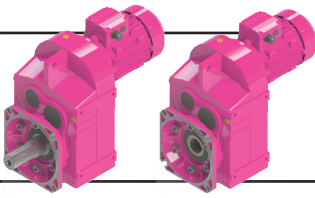

# Ölçü Sayfaları Dimension Pages Abmessungsseiten

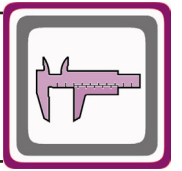

Mil ucu çektirme deliği DIN 332 sayfa 2 / Tapped center hole according to DIN 332, sheet 2 / Zentrierung mit Gewinde nach DIN 332, Blatt 2

## DR774.02

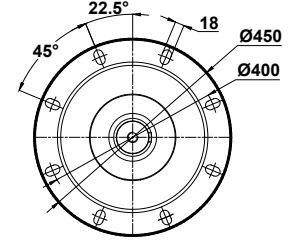
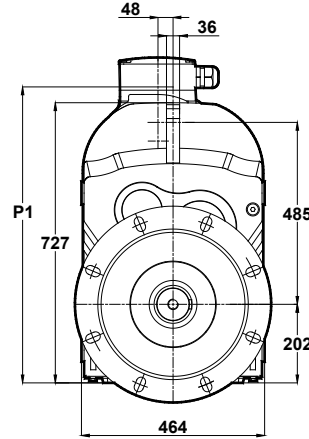
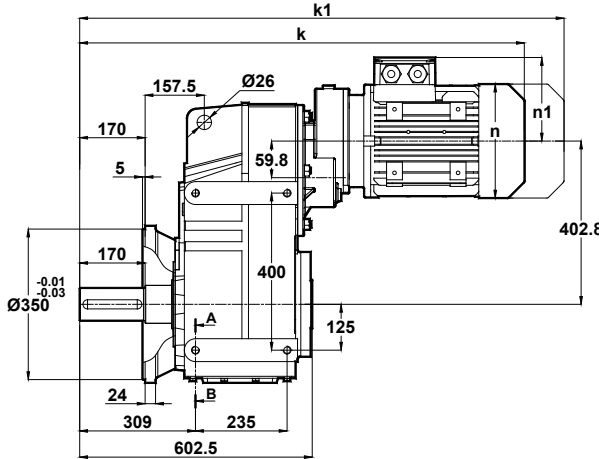

Klemens Pozisyonları  
Terminal Box Positions  
Klemmenkasten Positionen

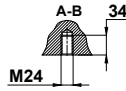
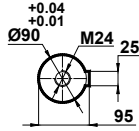

	80	90S	90L	100L
k	904	943	943	987
k1	997	1047.5	1047.5	1106.5
n	155	176	176	193
n1	121	132	132	147
p1	-	737	737	752

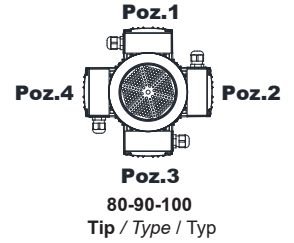

Opsiyonel flanş ölçüleri için sayfa 326'ya bakınız.  
Please see on page 326 for optional flange dimensions  
Siehe Seite 326 für auswählbare Flanschabmessungen

## DR774.03

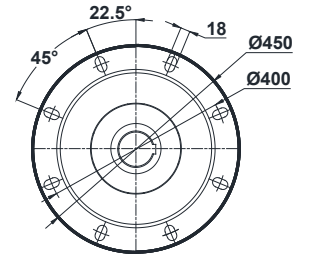
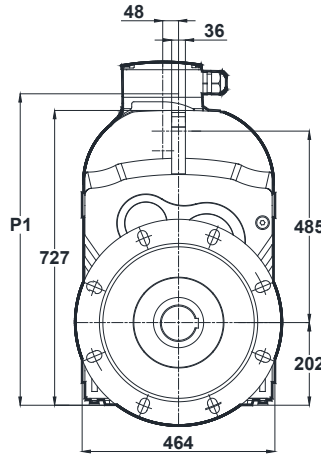
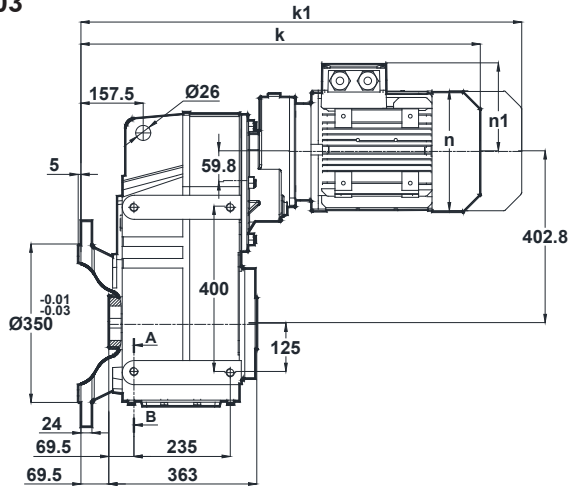

Klemens Pozisyonları  
Terminal Box Positions  
Klemmenkasten Positionen

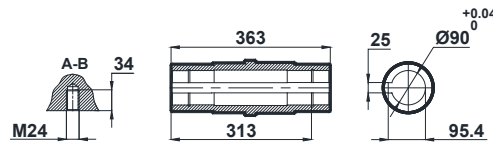

	80	90S	90L	100L
k	734	773	773	817
k1	827	877.5	877.5	936.5
n	155	176	176	193
n1	121	132	132	147
p1	-	737	737	752

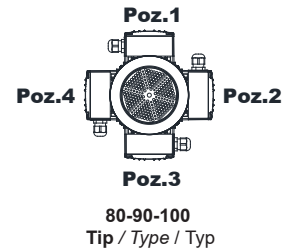

Opsiyonel flanş ölçüleri için sayfa 326'ya bakınız.  
Please see on page 326 for optional flange dimensions  
Siehe Seite 326 für auswählbare Flanschabmessungen

"k1" ölçüsü frenli redüktörlere aittir.  
Dimensions "k1" is for motors with brake.  
Maße "k1" ist für Bremsenmotoren.

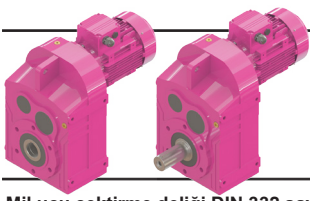

# Ölçü Sayfaları Dimension Pages Abmessungsseiten

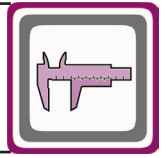

Mil ucu çekirtme deliği DIN 332 sayfa 2 / Tapped center hole according to DIN 332, sheet 2 / Zentrierung mit Gewinde nach DIN 332, Blatt 2

DR775.00  
DR776.00

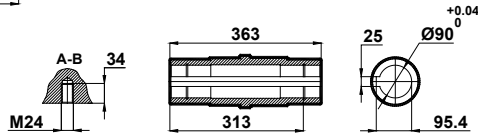
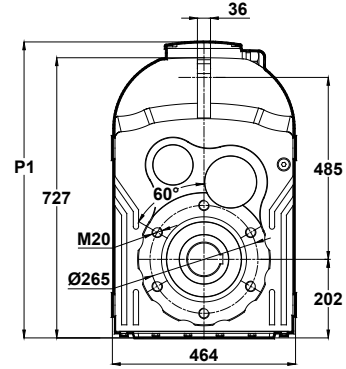
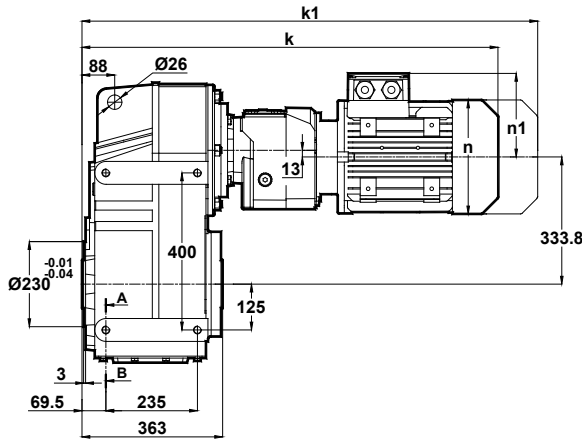

Klemens Pozisyonları  
Terminal Box Positions  
Klemmenkasten Positionen

	71	80	90S	90L
k	775	809	848	848
k1	866	902	952.5	952.5
n	137	155	176	176
n1	112	121	132	132
p1	-	-	-	-

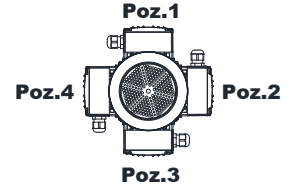

71-80-90  
Tip / Type / Typ

DR775.01  
DR776.01

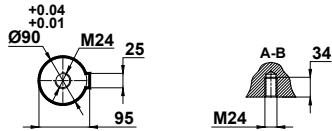
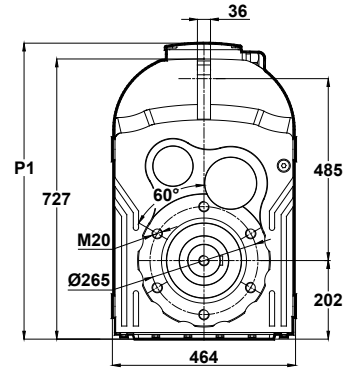
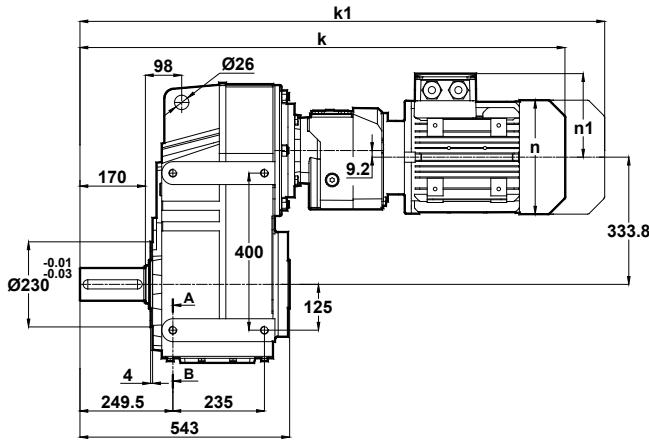

Klemens Pozisyonları  
Terminal Box Positions  
Klemmenkasten Positionen

	71	80	90S	90L
k	955	989	1028	1028
k1	1046	1082	1132.5	1132.5
n	137	155	176	176
n1	112	121	132	132
p1	-	-	-	-

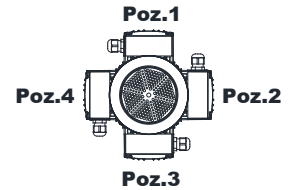

71-80-90  
Tip / Type / Typ

"k1" ölçüsü frenli redüktörlere aittir.  
Dimensions "k1" is for motors with brake.  
Maße "k1" ist für Bremsenmotoren.

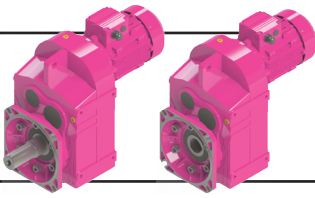

# Ölçü Sayfaları Dimension Pages Abmessungsseiten

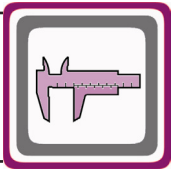

Mil ucu çektirme deliği DIN 332 sayfa 2 / Tapped center hole according to DIN 332, sheet 2 / Zentrierung mit Gewinde nach DIN 332, Blatt 2

DR775.02  
DR776.02

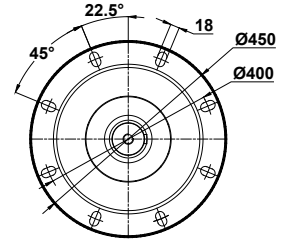
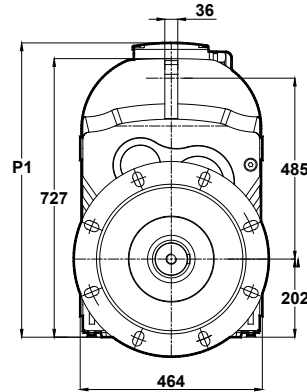
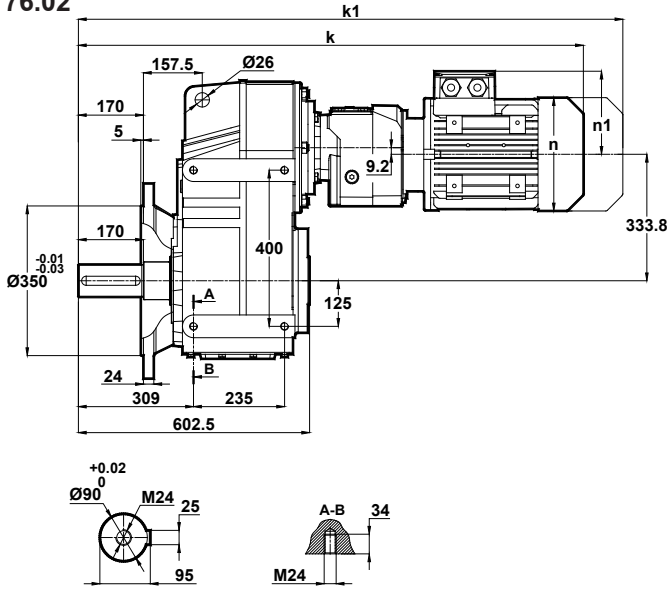

Klemens Pozisyonları  
Terminal Box Positions  
Klemmenkasten Positionen

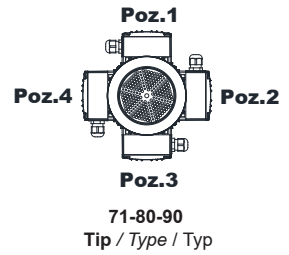

	71	80	90S	90L
k	1015	1049	1088	1088
k1	1106	1142	1192.5	1192.5
n	137	155	176	176
n1	112	121	132	132
p1	-	-	-	-

Opsiyonel flanş ölçüleri için sayfa 326'ya bakınız.  
Please see on page 326 for optional flange dimensions  
Siehe Seite 326 für auswählbare Flanschabmessungen

DR775.03  
DR776.03

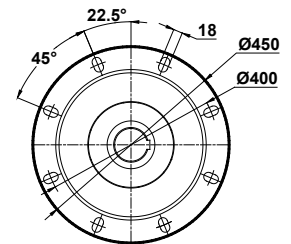
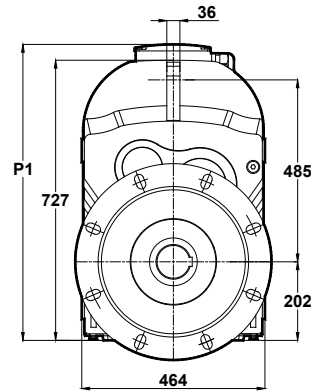
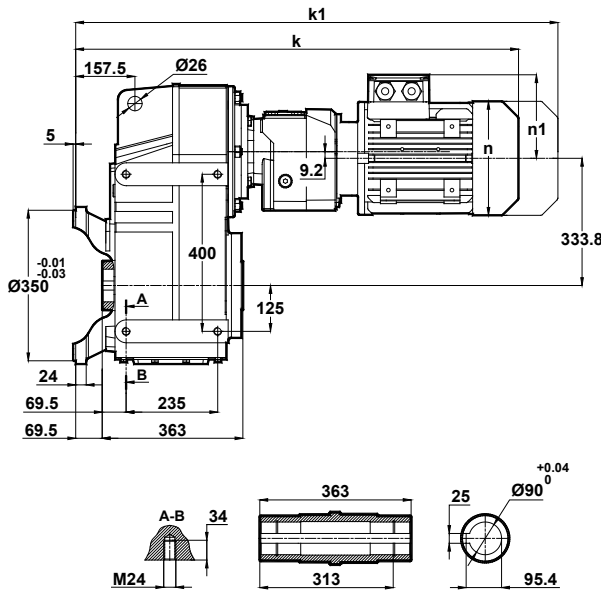

Klemens Pozisyonları  
Terminal Box Positions  
Klemmenkasten Positionen

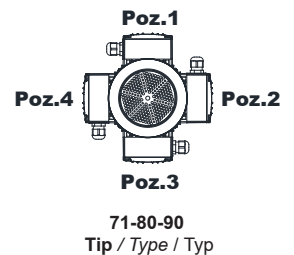

	71	80	90S	90L
k	845	879	918	918
k1	936	972	1022.5	1022.5
n	137	155	176	176
n1	112	121	132	132
p1	-	-	-	-

Opsiyonel flanş ölçüleri için sayfa 326'ya bakınız.  
Please see on page 326 for optional flange dimensions  
Siehe Seite 326 für auswählbare Flanschabmessungen

"k1" ölçüsü frenli redüktörlere aittir.  
Dimensions "k1" is for motors with brake.  
Maße "k1" ist für Bremsenmotoren.

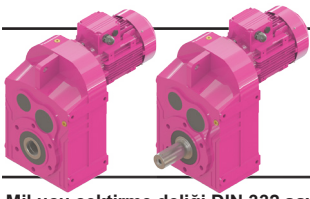

# Ölçü Sayfaları Dimension Pages Abmessungsseiten

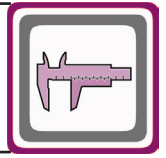

Mil ucu çektirme deliği DIN 332 sayfa 2 / Tapped center hole according to DIN 332, sheet 2 / Zentrierung mit Gewinde nach DIN 332, Blatt 2

DR872.00  
DR873.00

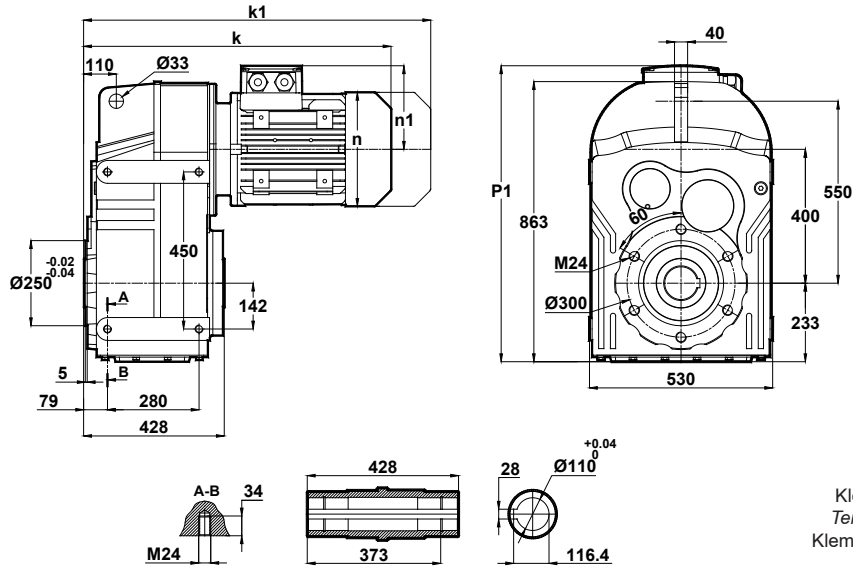

Klemens Pozisyonları  
Terminal Box Positions  
Klemmenkasten Positionen

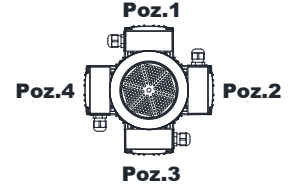

132-160-180-200-225-250-280  
Tip / Type / Typ

	132S	132M	160M	160L	180M	180L	200L	225S	225M	250M	280S	280M
k	809	809	885	885	956	956	998	1027	1052	1155	1216	1216
k1	939	939	1065	1065	1126.5	1126.5	1184.5	1192	1217	1325.5	1389	1395
n	257	257	315	315	347	347	390	434	434	480	544	544
n1	179	179	219	219	234	234	275	285	285	322	350	350
p1	-	-	-	-	877	877	908	918	918	955	983	983

DR872.01  
DR873.01

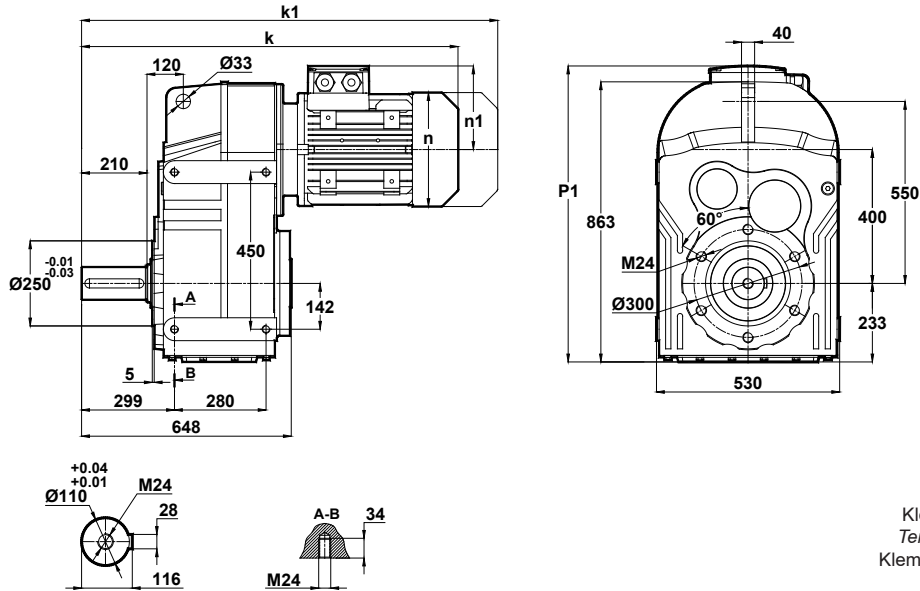

Klemens Pozisyonları  
Terminal Box Positions  
Klemmenkasten Positionen

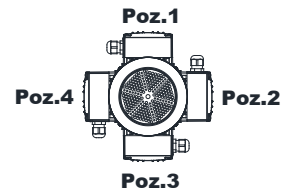

132-160-180-200-225-250-280  
Tip / Type / Typ

	132S	132M	160M	160L	180M	180L	200L	225S	225M	250M	280S	280M
k	1029	1029	1105	1105	1176	1176	1218	1247	1272	1375	1436	1436
k1	1159	1159	1285	1285	1346.5	1346.5	1404.5	1412	1437	1545.5	1609	1615
n	257	257	315	315	347	347	390	434	434	480	544	544
n1	179	179	219	219	234	234	275	285	285	322	350	350
p1	-	-	-	-	877	877	908	918	918	955	983	983

"k1" ölçüsü frenli redüktörlere aittir.  
Dimensions "k1" is for motors with brake.  
Maße "k1" ist für Bremsenmotoren.

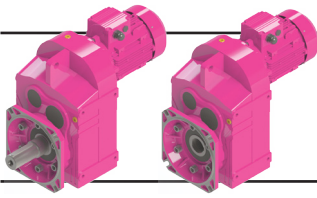

# Ölçü Sayfaları Dimension Pages Abmessungsseiten

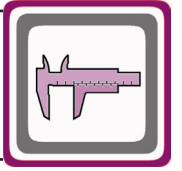

Mil ucu çektirme deliği DIN 332 sayfa 2 / Tapped center hole according to DIN 332, sheet 2 / Zentrierung mit Gewinde nach DIN 332, Blatt 2

DR872.02  
DR873.02

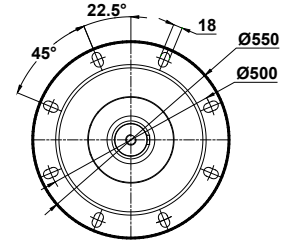
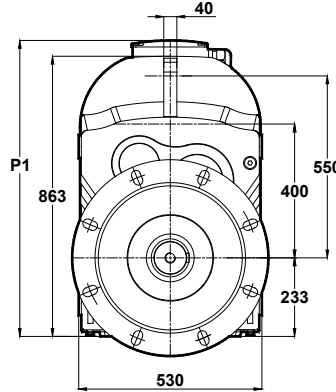
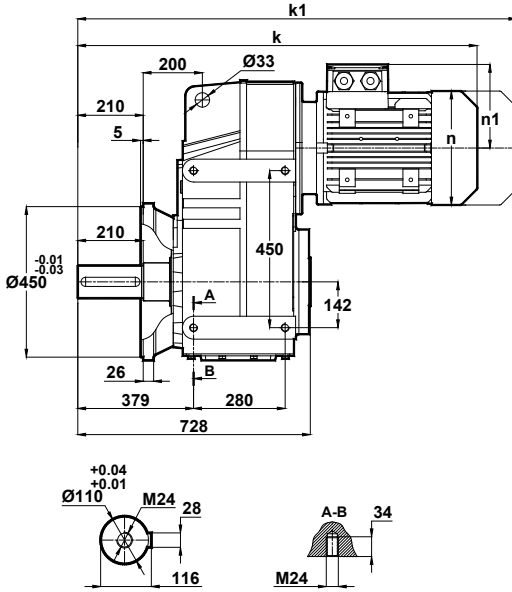

Klemens Pozisyonları  
Terminal Box Positions  
Klemmenkasten Positionen

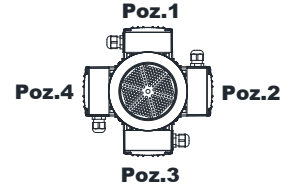

132-160-180-200-225-250-280  
Tip / Type / Typ

Opsiyonel flanş ölçüleri için sayfa 326'ya bakınız.  
Please see on page 326 for optional flange dimensions  
Siehe Seite 326 für auswählbare Flanschabmessungen

	132S	132M	160M	160L	180M	180L	200L	225S	225M	250M	280S	280M
k	1109	1109	1185	1185	1256	1256	1298	1327	1352	1455	1516	1516
k1	1239	1239	1365	1365	1426.5	1426.5	1484.5	1492	1517	1625.5	1689	1695
n	257	257	315	315	347	347	390	434	434	480	544	544
n1	179	179	219	219	234	234	275	285	285	322	350	350
p1	-	-	-	-	877	877	908	918	918	955	983	983

DR872.03  
DR873.03

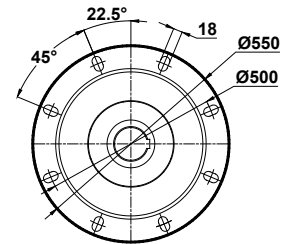
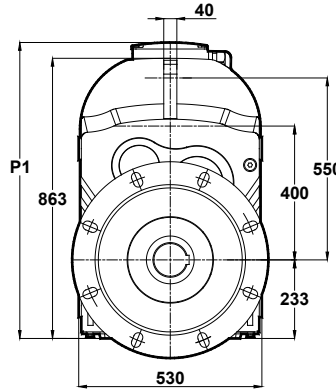
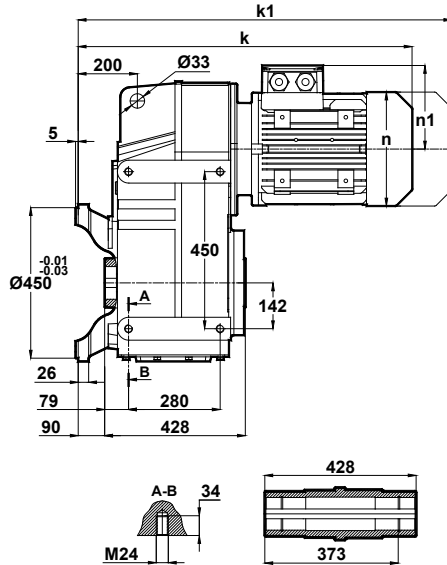

Klemens Pozisyonları  
Terminal Box Positions  
Klemmenkasten Positionen

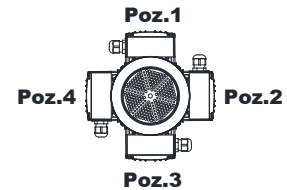

132-160-180-200-225-250-280  
Tip / Type / Typ

Opsiyonel flanş ölçüleri için sayfa 326'ya bakınız.  
Please see on page 326 for optional flange dimensions  
Siehe Seite 326 für auswählbare Flanschabmessungen

	132S	132M	160M	160L	180M	180L	200L	225S	225M	250M	280S	280M
k	899	899	975	975	1046	1046	1088	1117	1142	1245	1306	1306
k1	1029	1029	1155	1155	1216.5	1216.5	1274.5	1282	1307	1415.5	1479	1479
n	257	257	315	315	347	347	390	434	434	480	544	544
n1	179	179	219	219	234	234	275	285	285	322	350	350
p1	-	-	-	-	877	877	908	918	918	955	983	983

"k1" ölçüsü frenli redüktörlere aittir.  
Dimensions "k1" is for motors with brake.  
Maße "k1" ist für Bremsenmotoren.

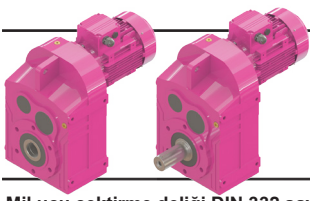

# Ölçü Sayfaları Dimension Pages Abmessungsseiten

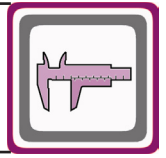

Mil ucu çektirme deliği DIN 332 sayfa 2 / Tapped center hole according to DIN 332, sheet 2 / Zentrierung mit Gewinde nach DIN 332, Blatt 2

DR874.00

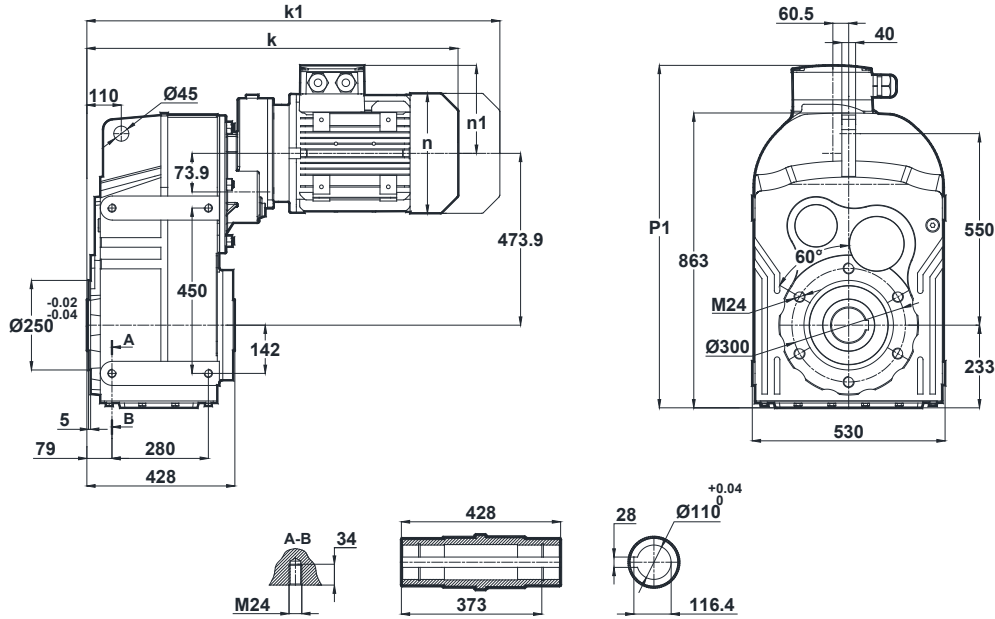

Klemens Pozisyonları  
Terminal Box Positions  
Klemmenkasten Positionen

	100L	112M	132S	132M
k	820	844	931	931
k1	939.5	948.5	1061	1061
n	193	215	257	257
n1	147	158	179	179
p1	-	-	886	886

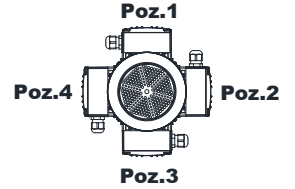

100-112-132  
Tip / Type / Typ

DR874.01

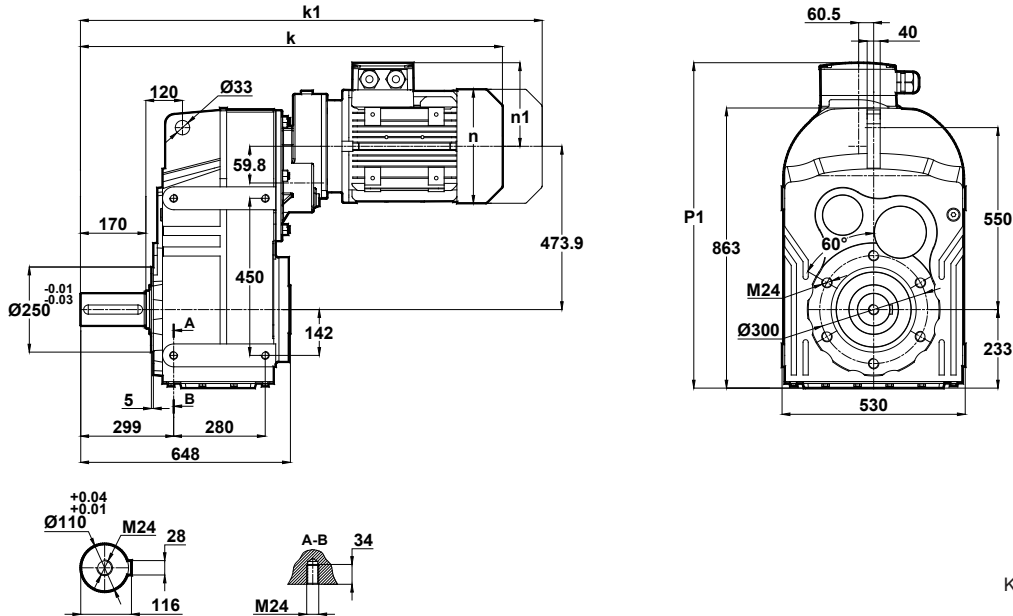

Klemens Pozisyonları  
Terminal Box Positions  
Klemmenkasten Positionen

	100L	112M	132S	132M
k	1040	1064	1151	1151
k1	1159.5	1168.5	1281	1281
n	193	215	257	257
n1	147	158	179	179
p1	-	-	886	886

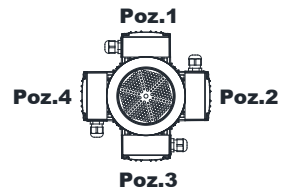

100-112-132  
Tip / Type / Typ

"k1" ölçüsü frenli redüktörlere aittir.  
Dimensions "k1" is for motors with brake.  
Maße "k1" ist für Bremsenmotoren.

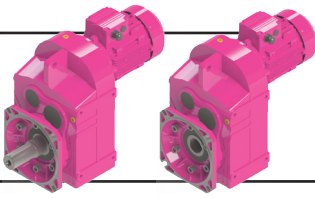

# Ölçü Sayfaları Dimension Pages Abmessungsseiten

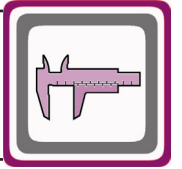

Mil ucu çektirme deliği DIN 332 sayfa 2 / Tapped center hole according to DIN 332, sheet 2 / Zentrierung mit Gewinde nach DIN 332, Blatt 2

## DR874.02

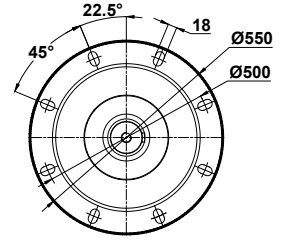
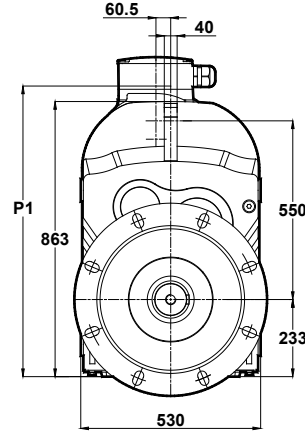
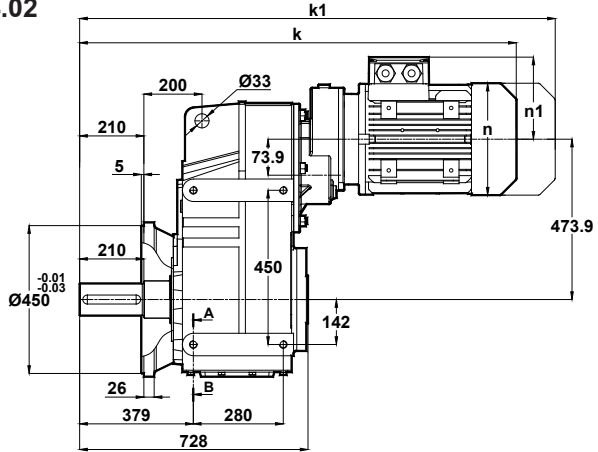

Klemens Pozisyonları  
Terminal Box Positions  
Klemmenkasten Positionen

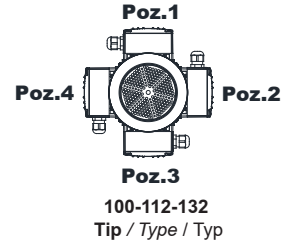
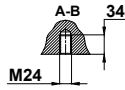
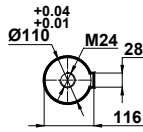

	100L	112M	132S	132M
k	1120	1144	1231	1231
k1	1239.5	1248.5	1361	1361
n	193	215	257	257
n1	147	158	179	179
p1	-	-	886	886

Opsiyonel flanş ölçüleri için sayfa 326'ya bakınız.  
Please see on page 326 for optional flange dimensions  
Siehe Seite 326 für auswählbare Flanschabmessungen

## DR874.03

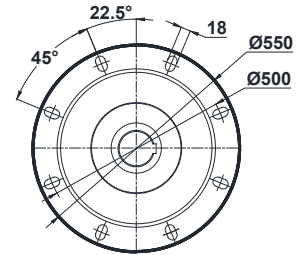
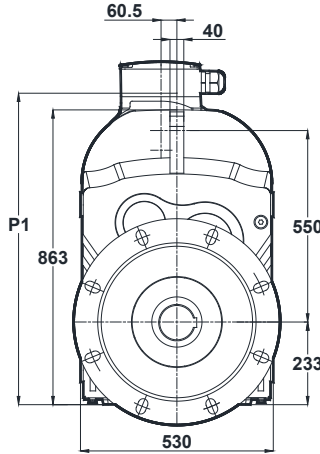
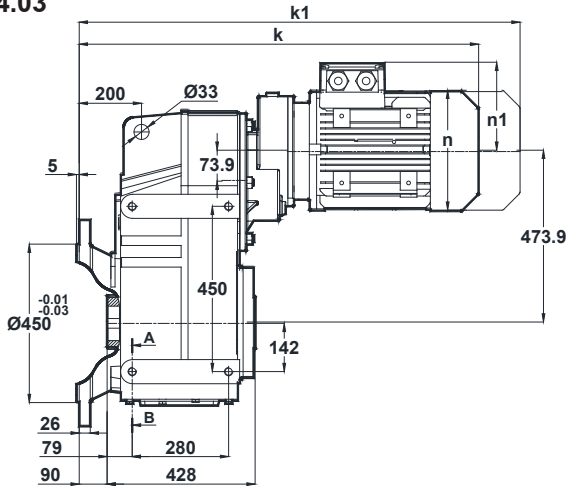

Klemens Pozisyonları  
Terminal Box Positions  
Klemmenkasten Positionen

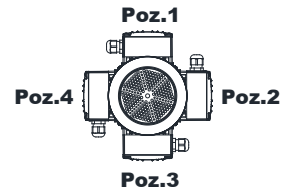
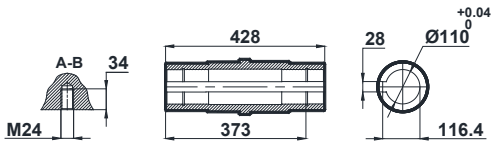

	100L	112M	132S	132M
k	910	934	1021	1021
k1	1029.5	1038.5	1151	1151
n	193	215	257	257
n1	147	158	179	179
p1	-	-	886	886

100-112-132  
Tip / Type / Typ

Opsiyonel flanş ölçüleri için sayfa 326'ya bakınız.  
Please see on page 326 for optional flange dimensions  
Siehe Seite 326 für auswählbare Flanschabmessungen

"k1" ölçüsü frenli redüktörlere aittir.  
Dimensions "k1" is for motors with brake.  
Maße "k1" ist für Bremsenmotoren.

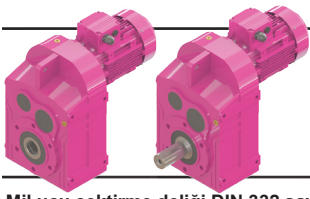

# Ölçü Sayfaları

## Dimension Pages

### Abmessungsseiten

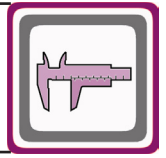

Mil ucu çektirme deliği DIN 332 sayfa 2 / Tapped center hole according to DIN 332, sheet 2 / Zentrierung mit Gewinde nach DIN 332, Blatt 2

DR875.00  
DR876.00

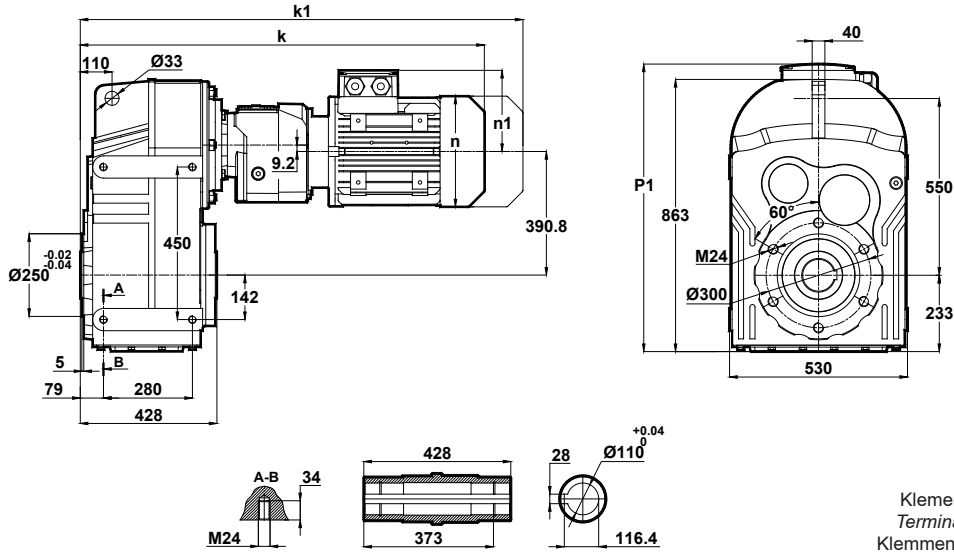

Klemens Pozisyonları  
Terminal Box Positions  
Klemmenkasten Positionen

	71	80	90S	90L	100L
k	838	872	911	911	958
k1	929	965	1015.5	1015.5	1077.5
n	137	155	176	176	193
n1	112	121	132	132	147
p1	736	745	756	756	771

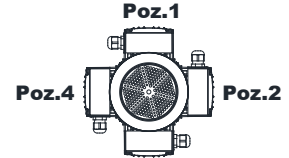

71-80-90-100  
Tip / Type / Typ

DR875.01  
DR876.01

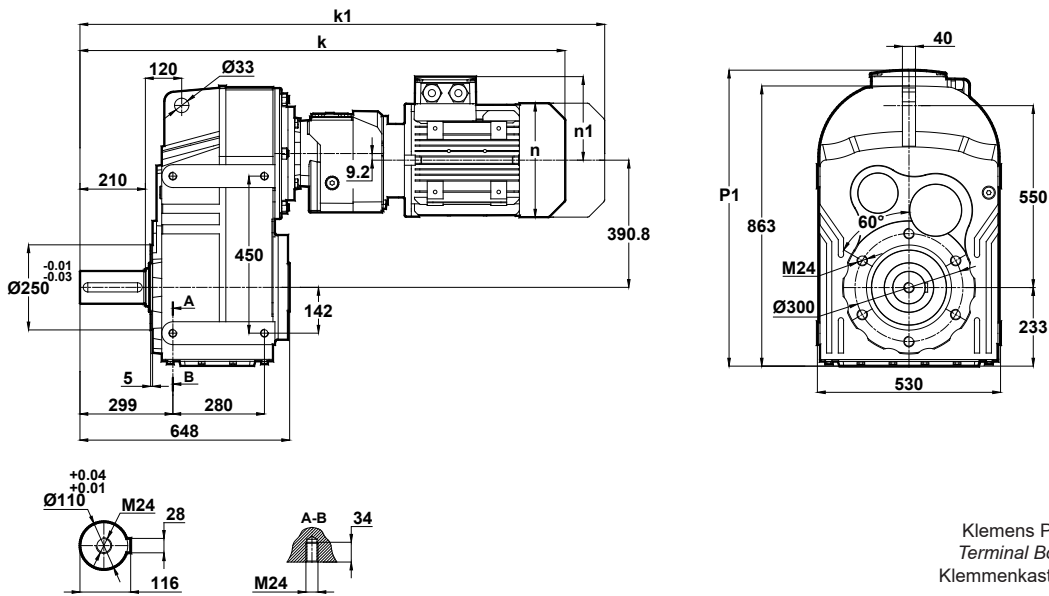

Klemens Pozisyonları  
Terminal Box Positions  
Klemmenkasten Positionen

	71	80	90S	90L	100L
k	1058	1092	1131	1131	1178
k1	1149	1185	1235.5	1235.5	1297.5
n	137	155	176	176	193
n1	112	121	132	132	147
p1	736	745	756	756	771

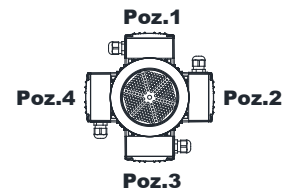

71-80-90-100  
Tip / Type / Typ

"k1" ölçüsü frenli redüktörlere aittir.  
Dimensions "k1" is for motors with brake.  
Maße "k1" ist für Bremsenmotoren.

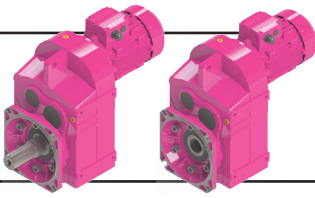

# Ölçü Sayfaları

## Dimension Pages

### Abmessungsseiten

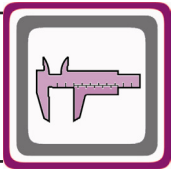

Mil ucu çektirme deliği DIN 332 sayfa 2 / Tapped center hole according to DIN 332, sheet 2 / Zentrierung mit Gewinde nach DIN 332, Blatt 2

DR875.02  
DR876.02

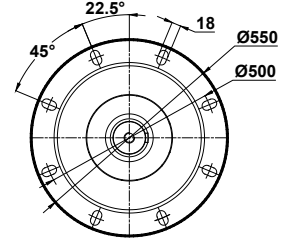
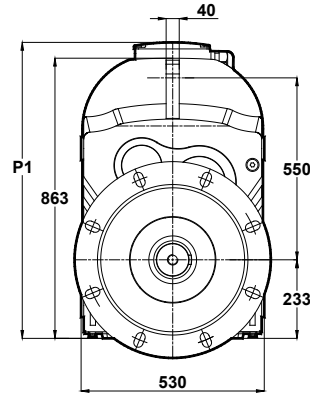
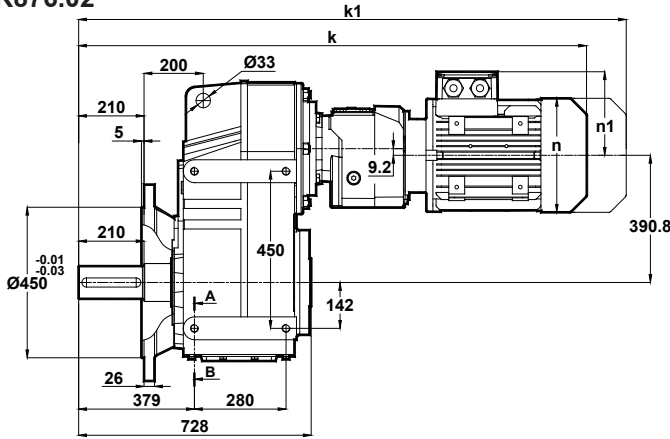

Klemens Pozisyonları  
Terminal Box Positions  
Klemmenkasten Positionen

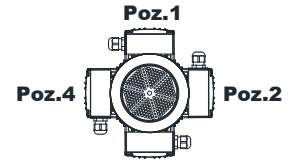

71-80-90-100  
Tip / Type / Typ

Opsiyonel flanş ölçüleri için sayfa 326'ya bakınız.  
Please see on page 326 for optional flange dimensions  
Siehe Seite 326 für auswählbare Flanschabmessungen

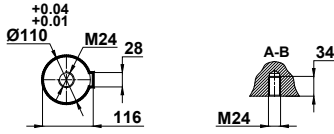

	71	80	90S	90L	100L
k	1138	1172	1211	1211	1258
k1	1229	1265	1315.5	1315.5	1377.5
n	137	155	176	176	193
n1	112	121	132	132	147
p1	736	745	756	756	771

DR875.03  
DR876.03

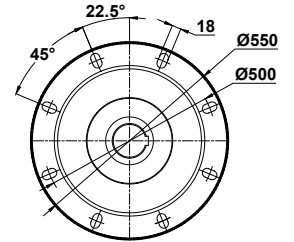
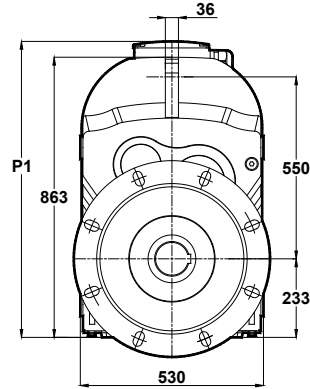
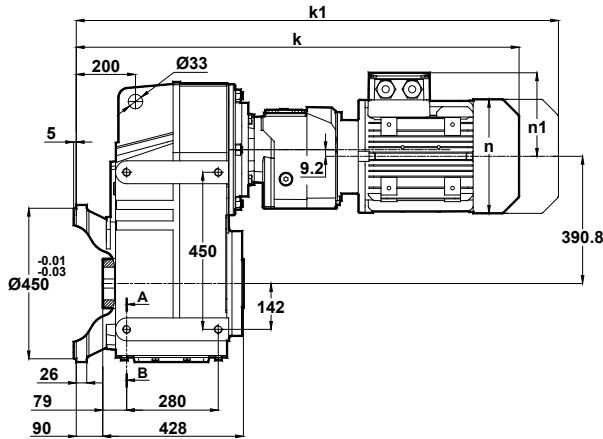

Klemens Pozisyonları  
Terminal Box Positions  
Klemmenkasten Positionen

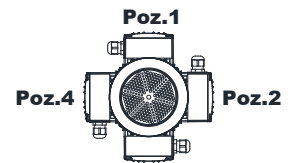

71-80-90-100  
Tip / Type / Typ

Opsiyonel flanş ölçüleri için sayfa 326'ya bakınız.  
Please see on page 326 for optional flange dimensions  
Siehe Seite 326 für auswählbare Flanschabmessungen

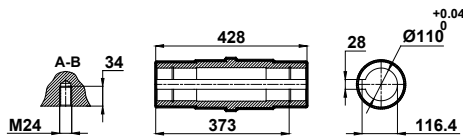

	71	80	90S	90L	100L
k	928	962	1001	1001	1048
k1	1019	1055	1105.5	1105.5	1167.5
n	137	155	176	176	193
n1	112	121	132	132	147
p1	736	745	756	756	771

"k1" ölçüsü frenli redüktörlere aittir.  
Dimensions "k1" is for motors with brake.  
Maße "k1" ist für Bremsenmotoren.

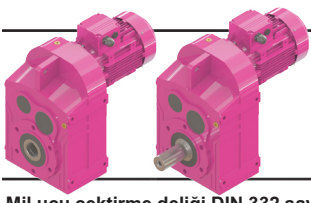

# Ölçü Sayfaları

## Dimension Pages

### Abmessungsseiten

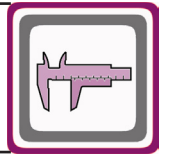

Mil ucu çektirme deliği DIN 332 sayfa 2 / Tapped center hole according to DIN 332, sheet 2 / Zentrierung mit Gewinde nach DIN 332, Blatt 2

DR972.00  
DR973.00

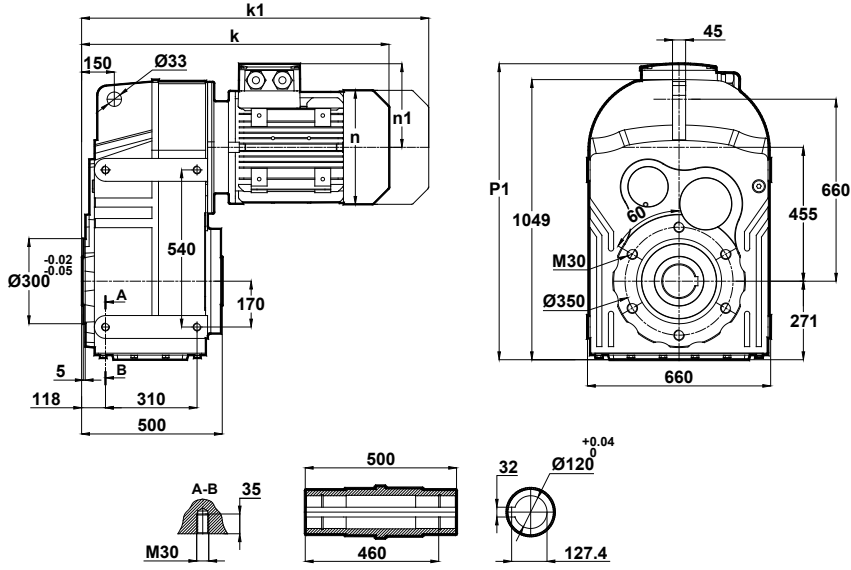

Klemens Pozisyonları  
Terminal Box Positions  
Klemmenkasten Positionen

Poz.1

Poz.4 Poz.2

Poz.3

160-180-200-225-250-280-315  
Tip / Type / Typ

	160M	160L	180M	180L	200L	225S	225M	250M	280S	280M	315S	315M
k	952	952	1023	1023	1065	1081	1106	1209	1270	1270	1425	1425
k1	1132	1132	1193.5	1193.5	1251.5	1246	1271	1379.5	1443	1449	-	-
n	315	315	347	347	390	434	434	480	544	544	614	614
n1	219	219	234	234	275	285	285	322	350	350	510	510
p1	-	-	-	-	-	-	-	-	1076	1076	1236	1236

DR972.01  
DR973.01

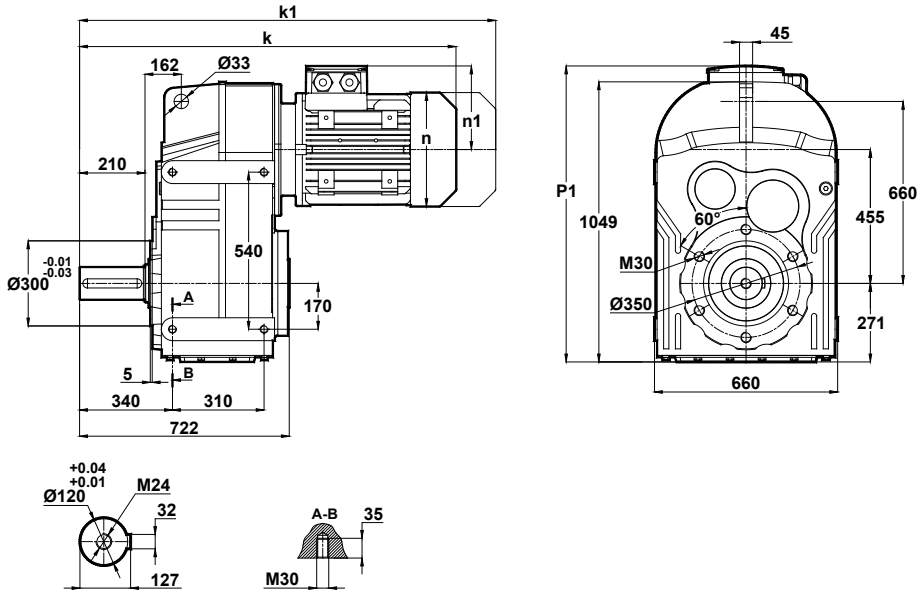

Klemens Pozisyonları  
Terminal Box Positions  
Klemmenkasten Positionen

Poz.1

Poz.4 Poz.2

Poz.3

160-180-200-225-250-280-315  
Tip / Type / Typ

	160M	160L	180M	180L	200L	225S	225M	250M	280S	280M	315S	315M
k	1174	1174	1245	1245	1287	1303	1328	1431	1492	1492	1647	1647
k1	1354	1354	1415.5	1415.5	1473.5	1468	1493	1601.5	1665	1498	-	-
n	315	315	347	347	390	434	434	480	544	544	614	614
n1	219	219	234	234	275	285	285	322	350	350	510	510
p1	-	-	-	-	-	-	-	-	1076	1076	1236	1236

"k1" ölçüsü frenli redüktörlere aittir.  
Dimensions "k1" is for motors with brake.  
Maße "k1" ist für Bremsenmotoren.

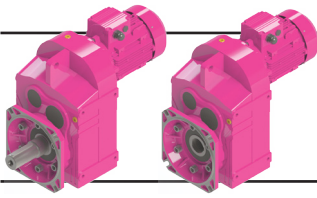

# Ölçü Sayfaları Dimension Pages Abmessungsseiten

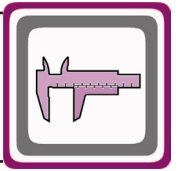

Mil ucu çektirme deliği DIN 332 sayfa 2 / Tapped center hole according to DIN 332, sheet 2 / Zentrierung mit Gewinde nach DIN 332, Blatt 2

DR972.02  
DR973.02

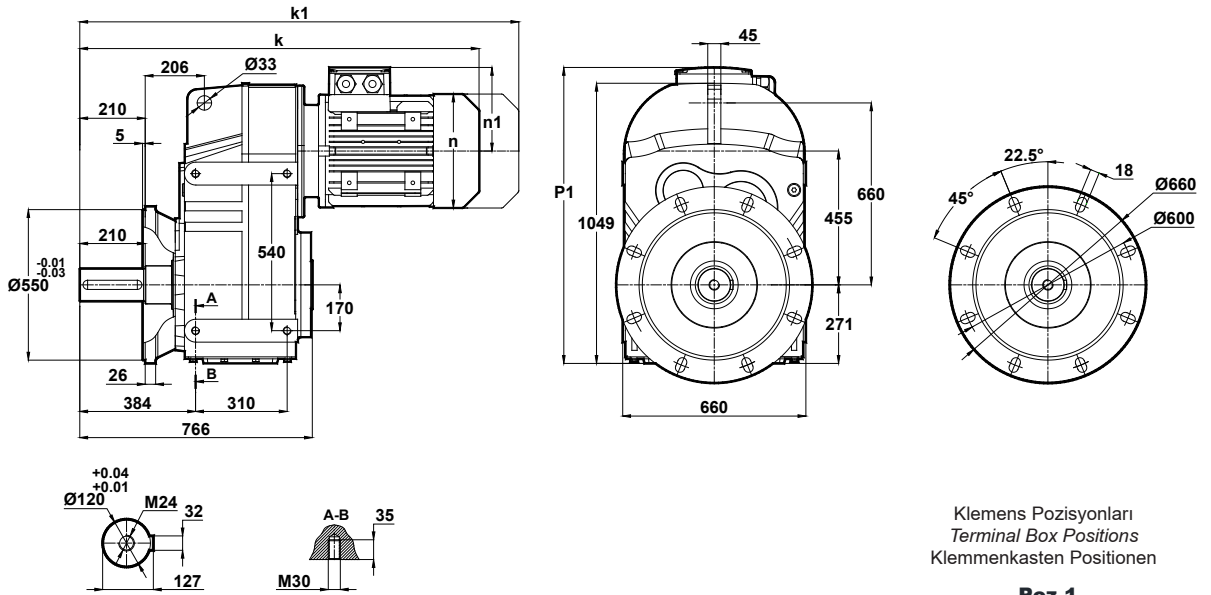

Klemens Pozisyonları  
Terminal Box Positions  
Klemmenkasten Positionen

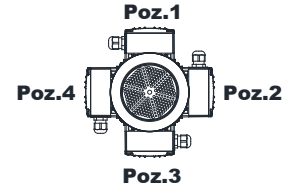

160-180-200-225-250-280-315  
Tip / Type / Typ

	160M	160L	180M	180L	200L	225S	225M	250M	280S	280M	315S	315M
k	1218	1218	1289	1289	1331	1347	1372	1475	1536	1536	1691	1691
k1	1398	1398	1459.5	1459.5	1517.5	1512	1537	1645.5	1709	1715	-	-
n	315	315	347	347	390	434	434	480	544	544	614	614
n1	219	219	234	234	275	285	285	322	350	350	510	510
p1	-	-	-	-	-	-	-	-	1076	1076	1236	1236

DR972.03  
DR973.03

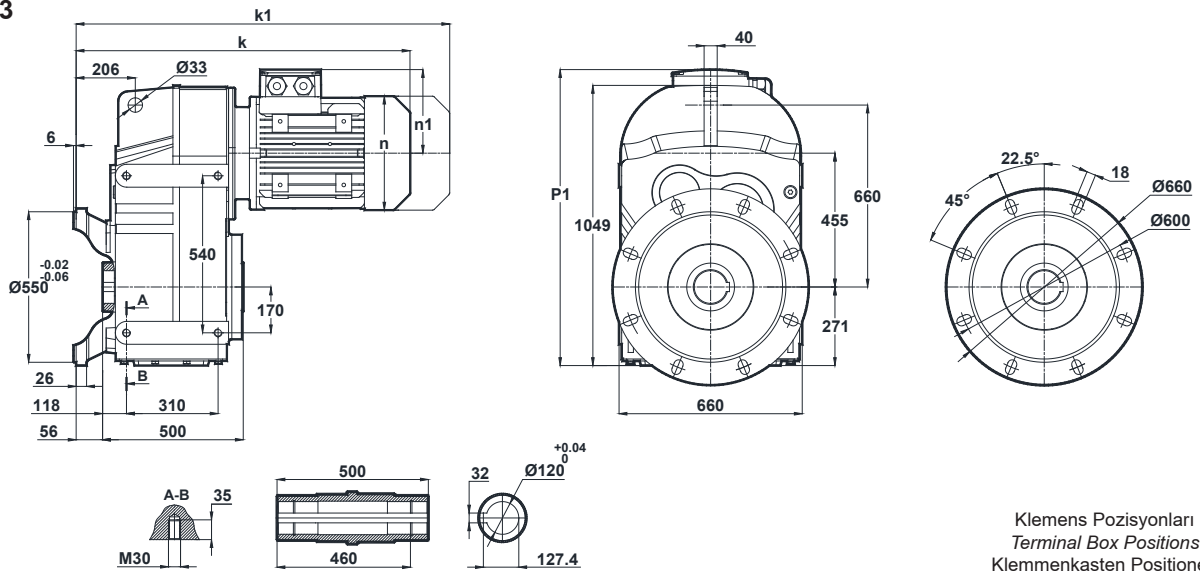

Klemens Pozisyonları  
Terminal Box Positions  
Klemmenkasten Positionen

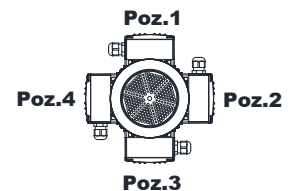

160-180-200-225-250-280-315  
Tip / Type / Typ

	160M	160L	180M	180L	200L	225S	225M	250M	280S	280M	315S	315M
k	1008	1008	1079	1079	1121	1137	1162	1265	1326	1326	1481	1481
k1	1188	1188	1249.5	1249.5	1307.5	1302	1327	1435.5	1499	1505	-	-
n	315	315	347	347	390	434	434	480	544	544	614	614
n1	219	219	234	234	275	285	285	322	350	350	510	510
p1	-	-	-	-	-	-	-	-	1076	1076	1236	1236

"k1" ölçüsü frenli redüktörlere aittir.  
Dimensions "k1" is for motors with brake.  
Maße "k1" ist für Bremsenmotoren.

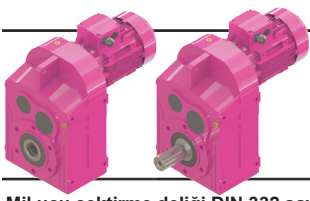

# Ölçü Sayfaları Dimension Pages Abmessungenseiten

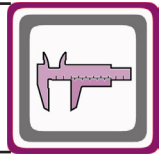

Mil ucu çektirme deliği DIN 332 sayfa 2 / Tapped center hole according to DIN 332, sheet 2 / Zentrierung mit Gewinde nach DIN 332, Blatt 2

## DR974.00

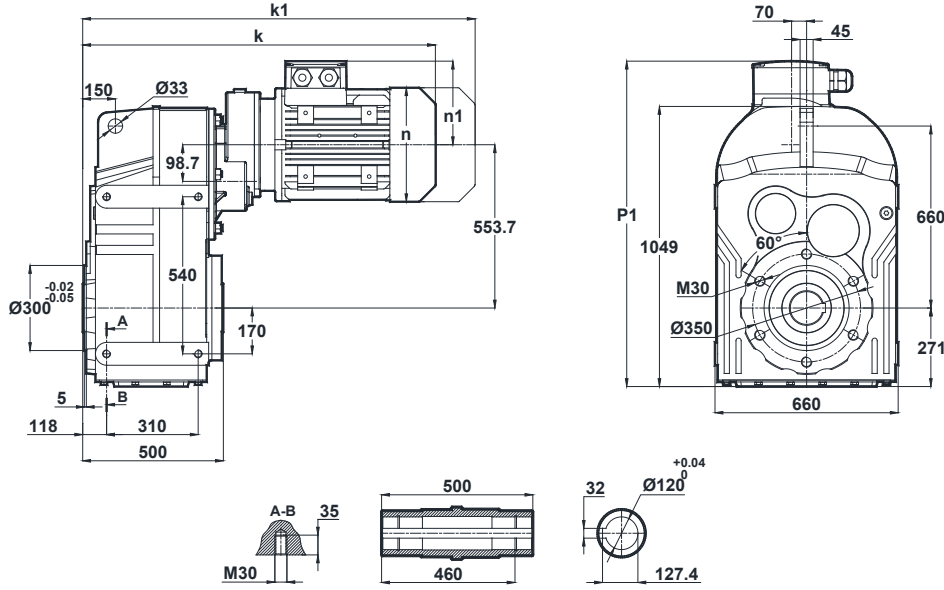

Klemens Pozisyonları  
Terminal Box Positions  
Klemmenkasten Positionen

	100L	112M	132S	132M
k	921	945	1032	1032
k1	1040.5	1049.5	1162	1162
n	193	215	257	257
n1	147	158	179	179
p1	-	-	-	-

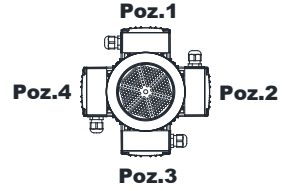

100-112-132  
Tip / Type / Typ

## DR974.01

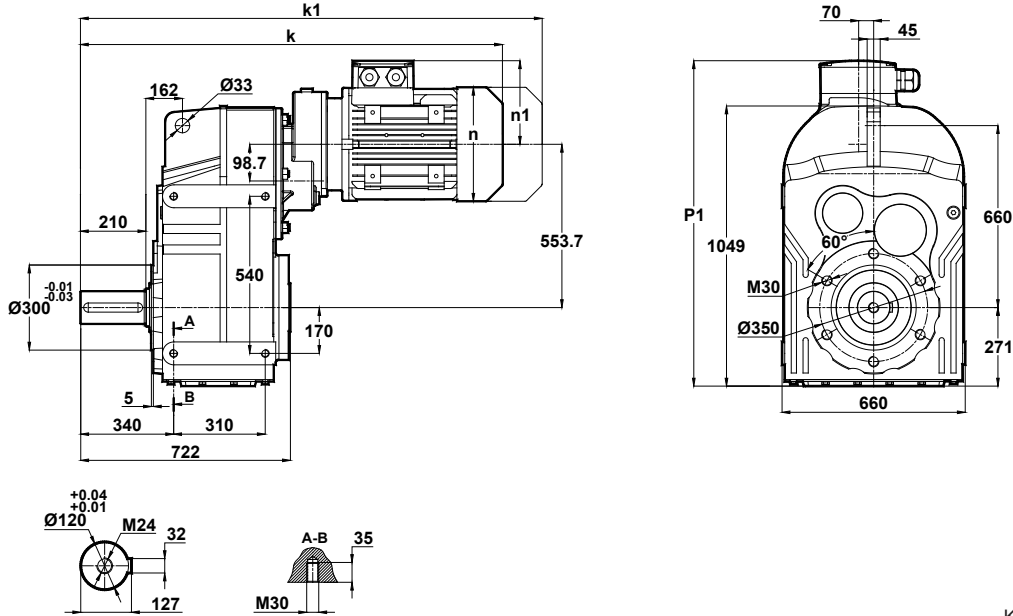

Klemens Pozisyonları  
Terminal Box Positions  
Klemmenkasten Positionen

	100L	112M	132S	132M
k	1143	1167	1254	1254
k1	1262.5	1271.5	1384	1384
n	193	215	257	257
n1	147	158	179	179
p1	-	-	-	-

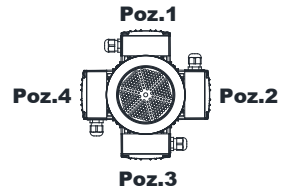

100-112-132  
Tip / Type / Typ

"k1" ölçüsü frenli redüktörlere aittir.  
Dimensions "k1" is for motors with brake.  
Maße "k1" ist für Bremsenmotoren.

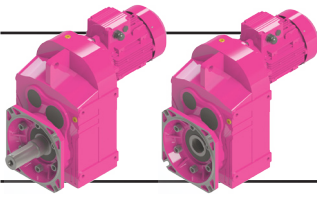

# Ölçü Sayfaları Dimension Pages Abmessungsseiten

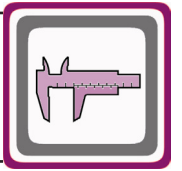

Mil ucu çektirme deliği DIN 332 sayfa 2 / Tapped center hole according to DIN 332, sheet 2 / Zentrierung mit Gewinde nach DIN 332, Blatt 2

## DR974.02

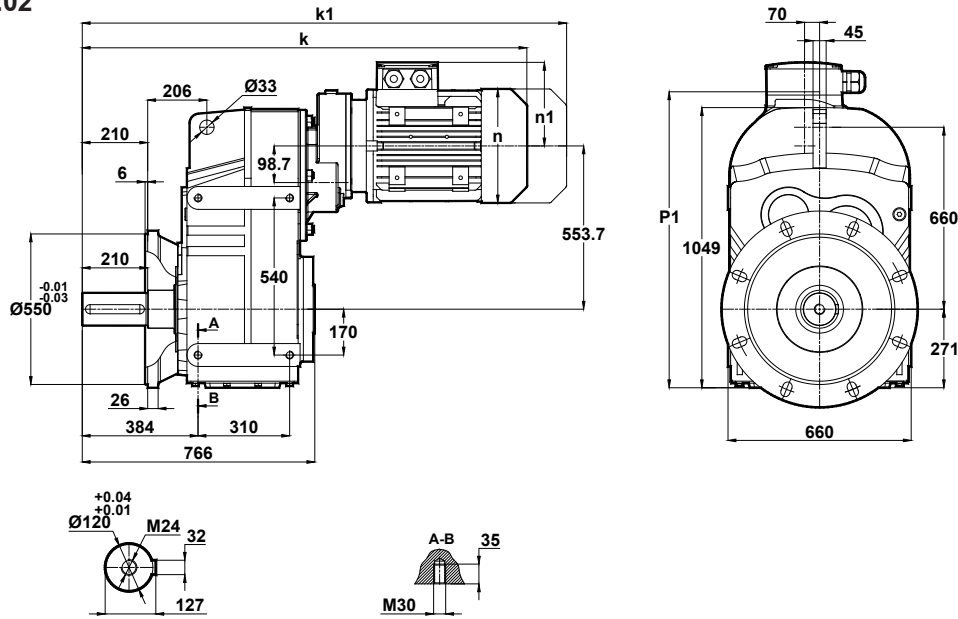

Klemens Pozisyonları  
Terminal Box Positions  
Klemmenkasten Positionen

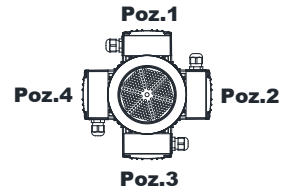

100-112-132  
Tip / Type / Typ

	100L	112M	132S	132M
k	1187	1211	1298	1298
k1	1306.5	1315.5	1428	1428
n	193	215	257	257
n1	147	158	179	179
p1	-	-	-	-

## DR974.03

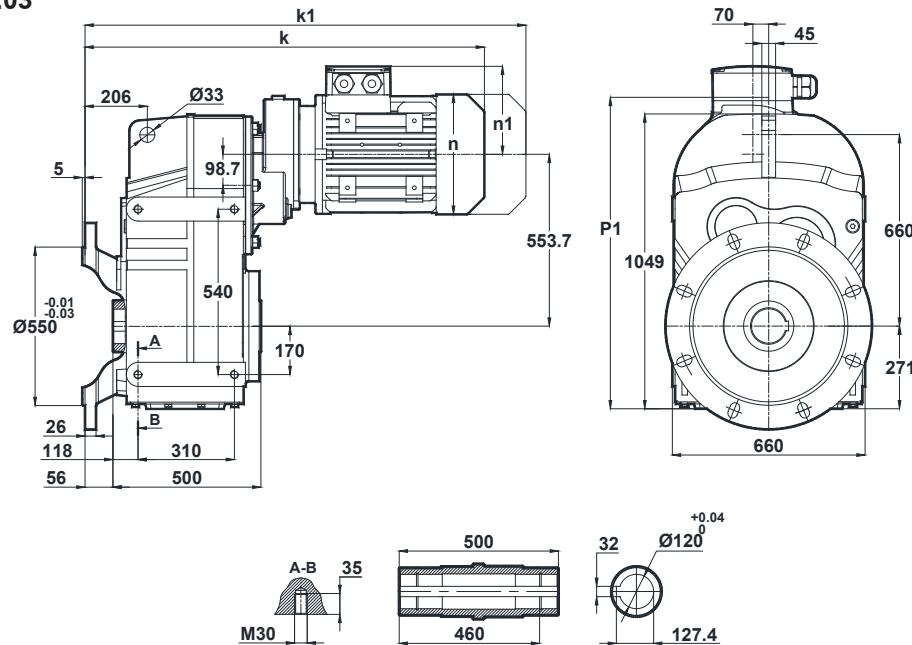

Klemens Pozisyonları  
Terminal Box Positions  
Klemmenkasten Positionen

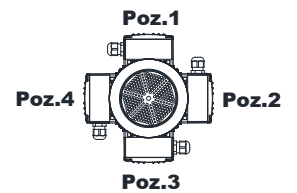

100-112-132  
Tip / Type / Typ

	100L	112M	132S	132M
k	977	1001	1088	1088
k1	1096.5	1105.5	1218	1218
n	193	215	257	257
n1	147	158	179	179
p1	-	-	-	-

"k1" ölçüsü frenli redüktörlere aittir.  
Dimensions "k1" is for motors with brake.  
Maße "k1" ist für Bremsenmotoren.

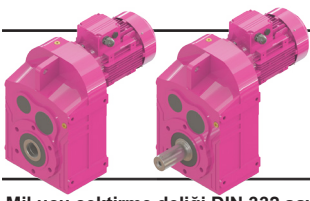

# Ölçü Sayfaları Dimension Pages Abmessungsseiten

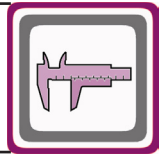

Mil ucu çekirtme deliği DIN 332 sayfa 2 / Tapped center hole according to DIN 332, sheet 2 / Zentrierung mit Gewinde nach DIN 332, Blatt 2

DR975.00  
DR976.00

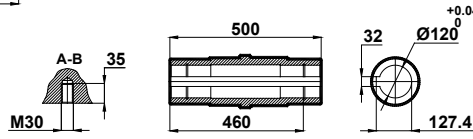
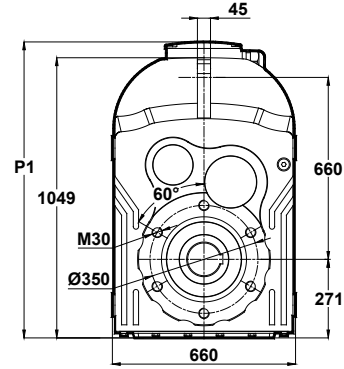
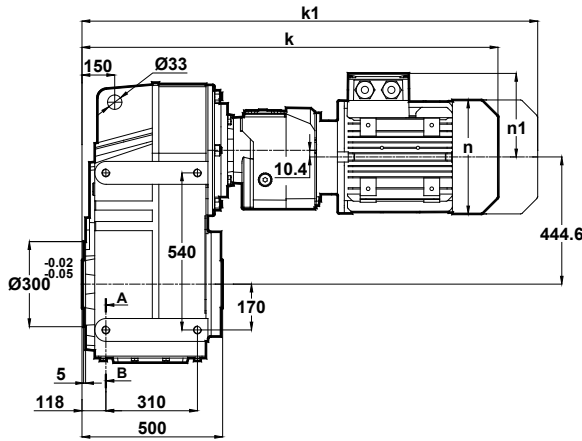

Klemens Pozisyonları  
Terminal Box Positions  
Klemmenkasten Positionen

	80	90S	90L	100L
k	1000	1039	1039	1083
k1	1093	1143.5	1143.5	1202.5
n	155	176	176	193
n1	121	132	132	147
p1	-	-	-	-

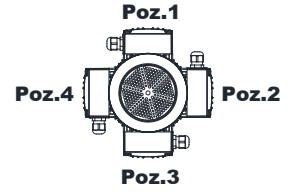

80-90-100  
Tip / Type / Typ

DR975.01  
DR976.01

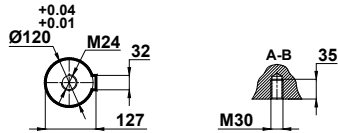
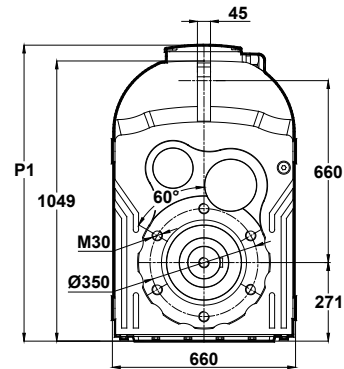
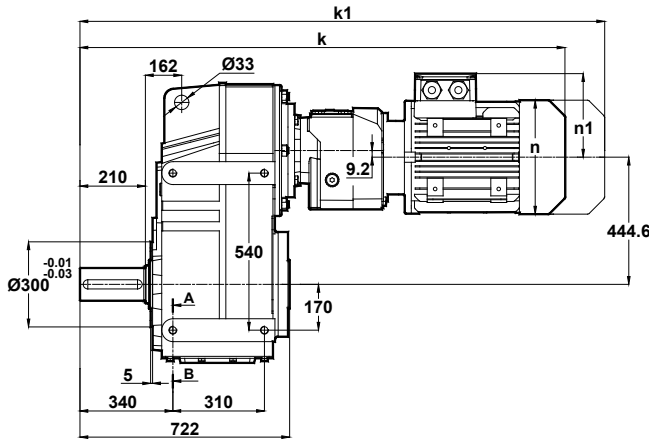

Klemens Pozisyonları  
Terminal Box Positions  
Klemmenkasten Positionen

	80	90S	90L	100L
k	1222	1261	1261	1305
k1	1315	1365.5	1365.5	1424.5
n	155	176	176	193
n1	121	132	132	147
p1	-	-	-	-

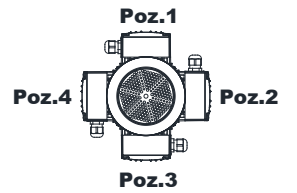

80-90-100  
Tip / Type / Typ

"k1" ölçüsü frenli redüktörlere aittir.  
Dimensions "k1" is for motors with brake.  
Maße "k1" ist für Bremsenmotoren.

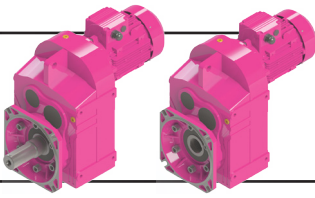

# Ölçü Sayfaları

## Dimension Pages

### Abmessungsseiten

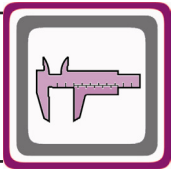

Mil ucu çektirme deliği DIN 332 sayfa 2 / Tapped center hole according to DIN 332, sheet 2 / Zentrierung mit Gewinde nach DIN 332, Blatt 2

DR975.02  
DR976.02

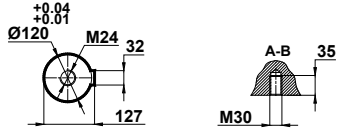
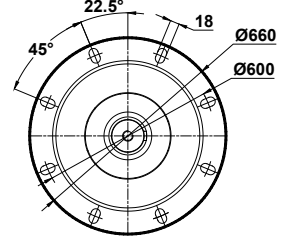
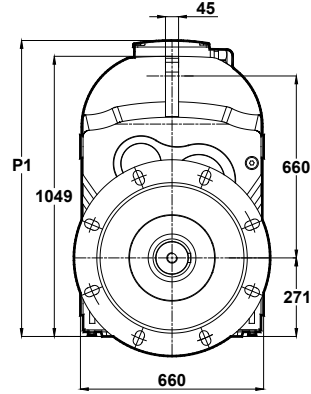
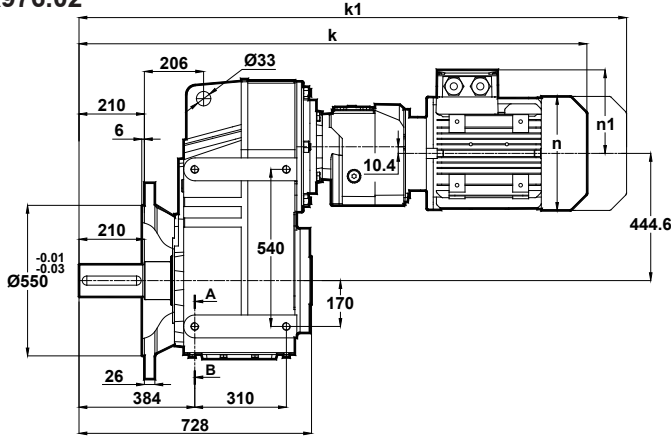

	80	90S	90L	100L
k	1266	1305	1305	1349
k1	1359	1409.5	1409.5	1468.5
n	155	176	176	193
n1	121	132	132	147
p1	-	-	-	-

Klemens Pozisyonları  
Terminal Box Positions  
Klemmenkasten Positionen

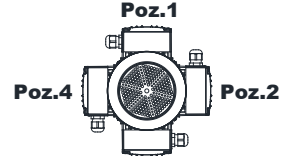

Poz.1

80-90-100  
Tip / Type / Typ

DR975.03  
DR976.03

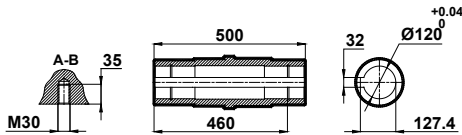
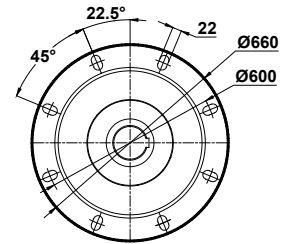
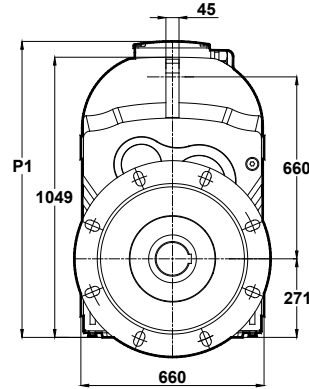
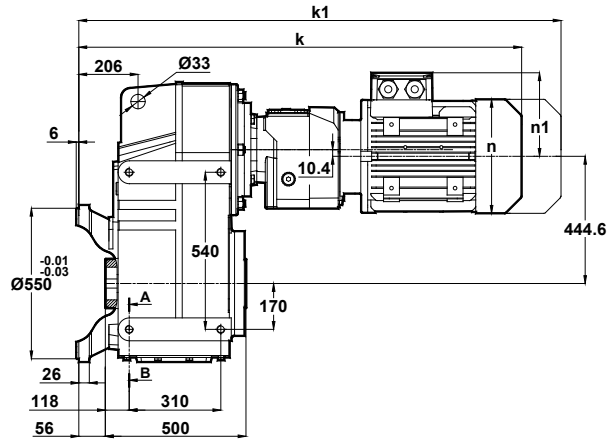

	80	90S	90L	100L
k	1056	1095	1095	1139
k1	1149	1199.5	1199.5	1258.5
n	155	176	176	193
n1	121	132	132	147
p1	-	-	-	-

Klemens Pozisyonları  
Terminal Box Positions  
Klemmenkasten Positionen

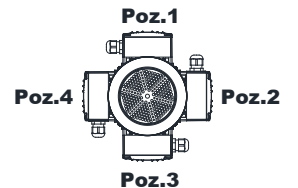

Poz.1

80-90-100  
Tip / Type / Typ

"k1" ölçüsü frenli redüktörlere aittir.  
Dimensions "k1" is for motors with brake.  
Maße "k1" ist für Bremsenmotoren.

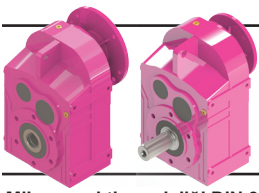

# Ölçü Sayfaları

## Dimension Pages

### Abmessungsseiten

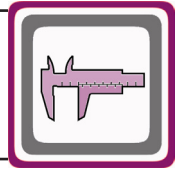

Mil ucu çektirme deliği DIN 332 sayfa 2 / Tapped center hole according to DIN 332, sheet 2 / Zentrierung mit Gewinde nach DIN 332, Blatt 2

DN072.00  
DN073.00

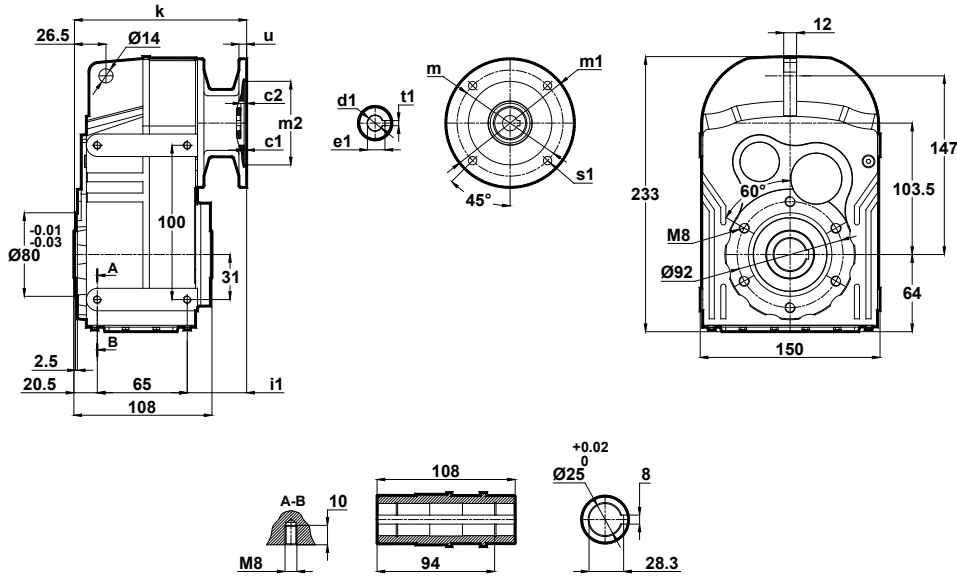

	c1	c2	s1	m	m1	m2(H7)	i1	u	k	d1	t1	e1
63/B5	4	5	10	115	140	95	55	10	145	11	4	12.8
63/B14	2.5	5	5.5	75	90	60	55	10	145	11	4	12.8
71/B5	4	5	11	130	160	110	56	12	146.5	14	5	16.3
71/B14	3	4.5	7	85	105	70	56	10	146.5	14	5	16.3
80/B5	4	5	12	165	200	130	71	12	161.5	19	6	21.8
80/B14	4	5	7	100	120	80	71	12	161.5	19	6	21.8
90/B5	4	5	12	165	200	130	71	12	161.5	24	8	27.3
90/B14	4	5	9	115	140	95	71	12	161.5	24	8	27.3
100/B5	4	5	15	215	250	180	82	12	172.5	28	8	31.3
100/B14	4	5.5	9	130	160	110	82	12	172.5	28	8	31.3

DN072.01  
DN073.01

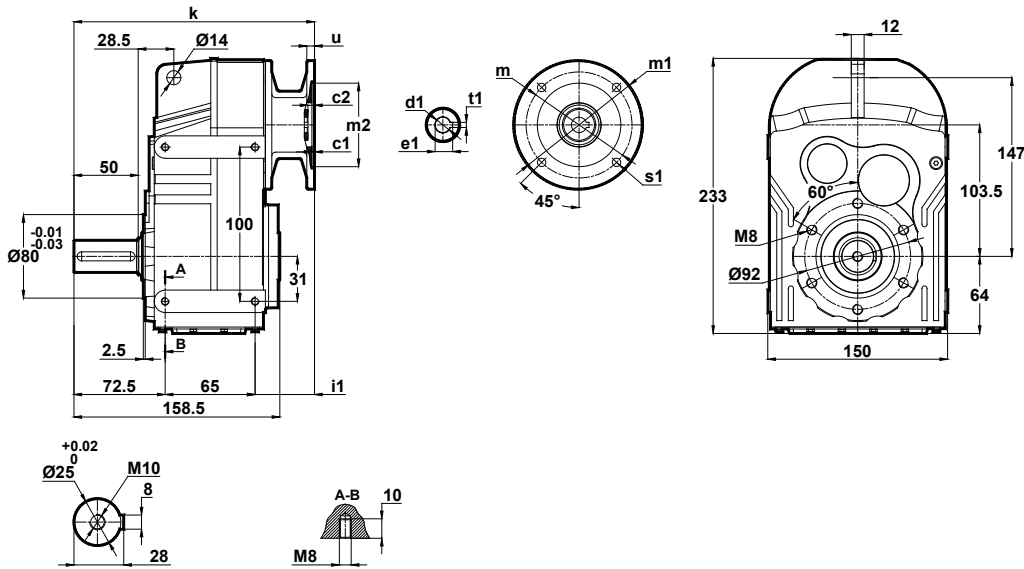

	c1	c2	s1	m	m1	m2(H7)	i1	u	k	d1	t1	e1
63/B5	4	5	10	115	140	95	55	10	197	11	4	12.8
63/B14	2.5	5	5.5	75	90	60	55	10	197	11	4	12.8
71/B5	4	5	11	130	160	110	56	12	198.5	14	5	16.3
71/B14	3	4.5	7	85	105	70	56	10	198.5	14	5	16.3
80/B5	4	5	12	165	200	130	71	12	213.5	19	6	21.8
80/B14	4	5	7	100	120	80	71	12	213.5	19	6	21.8
90/B5	4	5	12	165	200	130	71	12	213.5	24	8	27.3
90/B14	4	5	9	115	140	95	71	12	213.5	24	8	27.3
100/B5	4	5	15	215	250	180	82	12	224.5	28	8	31.3
100/B14	4	5.5	9	130	160	110	82	12	224.5	28	8	31.3

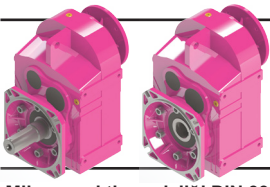

# Ölçü Sayfaları Dimension Pages Abmessungenseiten

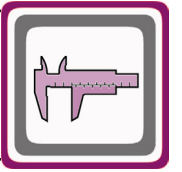

Mil ucu çektirme deliği DIN 332 sayfa 2 / Tapped center hole according to DIN 332, sheet 2 / Zentrierung mit Gewinde nach DIN 332, Blatt 2

DN072.02  
DN073.02

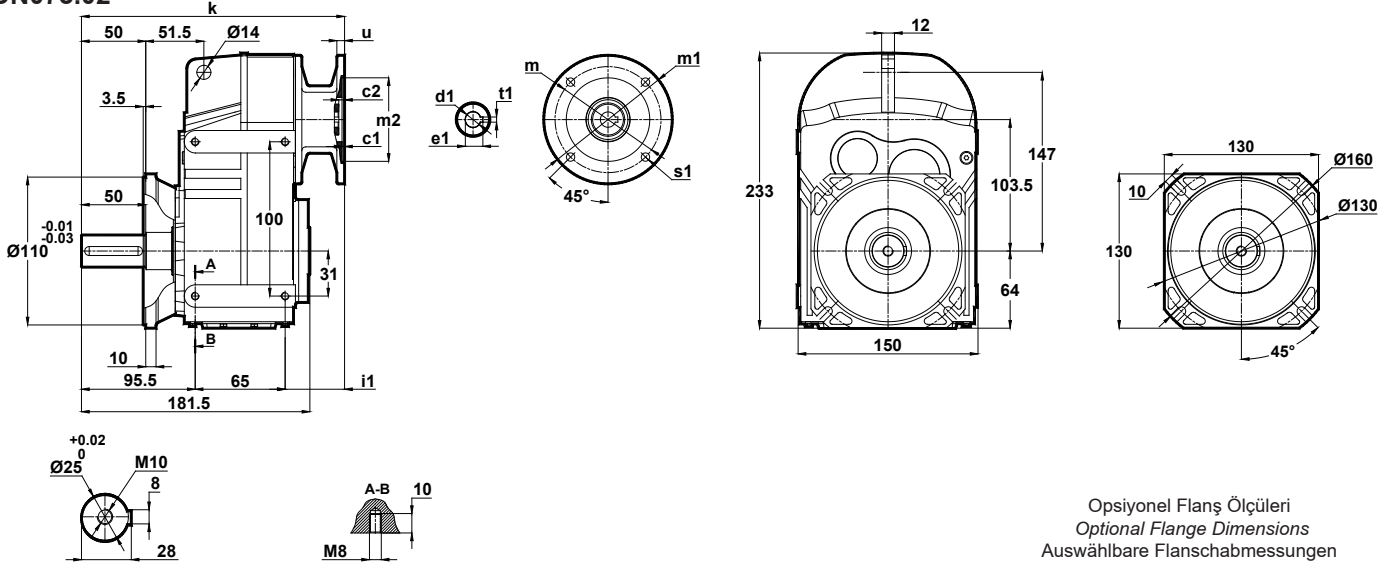

Opsiyonel Flanş Ölçüleri  
Optional Flange Dimensions  
Auswählbare Flanschabmessungen

	c1	c2	s1	m	m1	m2(H7)	i1	u	k	d1	t1	e1
63/B5	4	5	10	115	140	95	55	10	220	11	4	12.8
63/B14	2.5	5	5.5	75	90	60	55	10	220	11	4	12.8
71/B5	4	5	11	130	160	110	56	12	221.5	14	5	16.3
71/B14	3	4.5	7	85	105	70	56	10	221.5	14	5	16.3
80/B5	4	5	12	165	200	130	71	12	236.5	19	6	21.8
80/B14	4	5	7	100	120	80	71	12	236.5	19	6	21.8
90/B5	4	5	12	165	200	130	71	12	236.5	24	8	27.3
90/B14	4	5	9	115	140	95	71	12	236.5	24	8	27.3
100/B5	4	5	15	215	250	180	82	12	247.5	28	8	31.3
100/B14	4	5.5	9	130	160	110	82	12	247.5	28	8	31.3

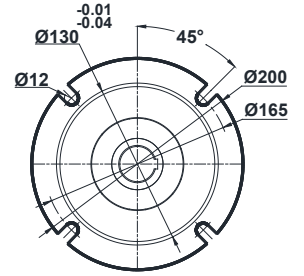

DN072.03  
DN073.03

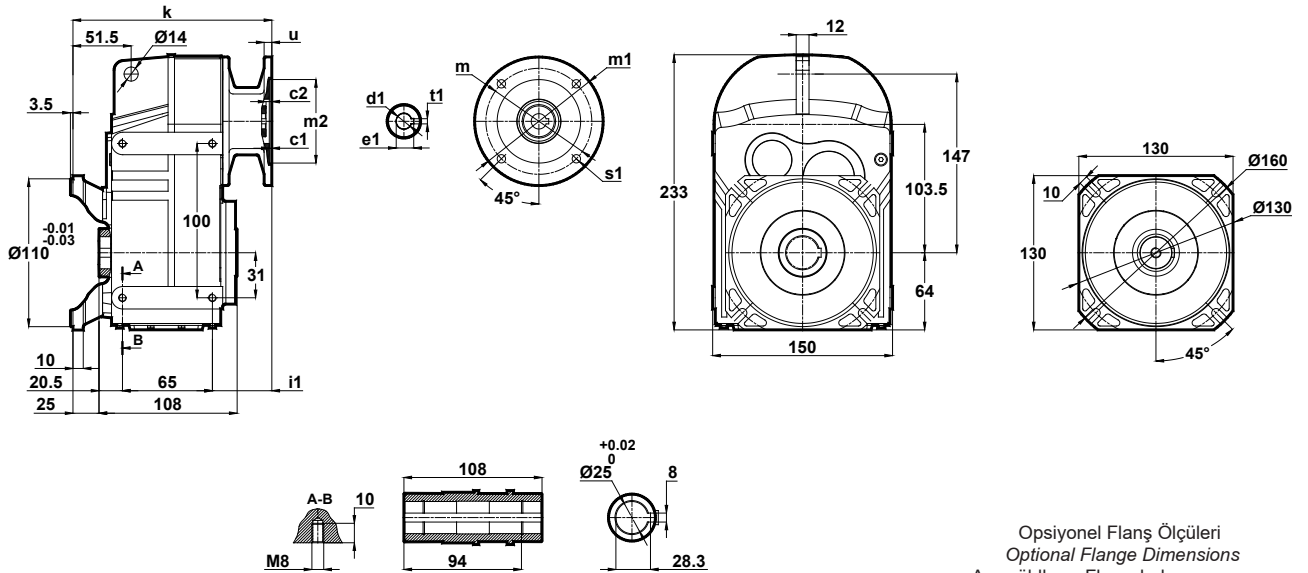

Opsiyonel Flanş Ölçüleri  
Optional Flange Dimensions  
Auswählbare Flanschabmessungen

	c1	c2	s1	m	m1	m2(H7)	i1	u	k	d1	t1	e1
63/B5	4	5	10	115	140	95	55	10	170	11	4	12.8
63/B14	2.5	5	5.5	75	90	60	55	10	170	11	4	12.8
71/B5	4	5	11	130	160	110	56	12	171.5	14	5	16.3
71/B14	3	4.5	7	85	105	70	56	10	171.5	14	5	16.3
80/B5	4	5	12	165	200	130	71	12	186.5	19	6	21.8
80/B14	4	5	7	100	120	80	71	12	186.5	19	6	21.8
90/B5	4	5	12	165	200	130	71	12	186.5	24	8	27.3
90/B14	4	5	9	115	140	95	71	12	186.5	24	8	27.3
100/B5	4	5	15	215	250	180	82	12	197.5	28	8	31.3
100/B14	4	5.5	9	130	160	110	82	12	197.5	28	8	31.3

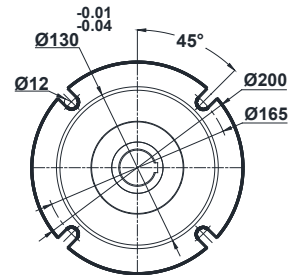

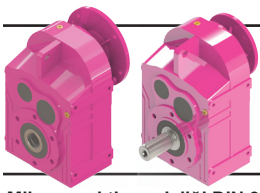

# Ölçü Sayfaları

## Dimension Pages

### Abmessungsseiten

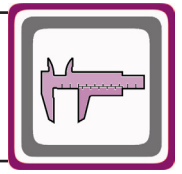

Mil ucu çektirme deliği DIN 332 sayfa 2 / Tapped center hole according to DIN 332, sheet 2 / Zentrierung mit Gewinde nach DIN 332, Blatt 2

DN172.00  
DN173.00

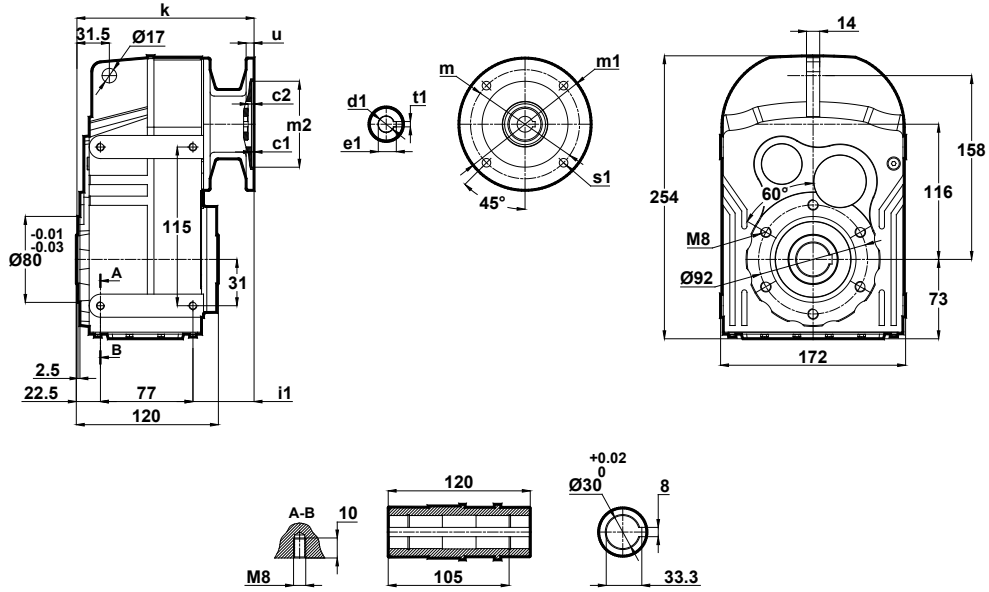

	c1	c2	s1	m	m1	m2(H7)	i1	u	k	d1	t1	e1
63/B5	4		10	115	140	95						
63/B14	2.5	5	5.5	75	90	60	55	10	154	11	4	12.8
71/B5	4	5	11	130	160	110	56	12	156	14	5	16.3
71/B14	3	4.5	7	85	105	70		10				
80/B5	4	5	12	165	200	130	71	12	171	19	6	21.8
80/B14			7	100	120	80						
90/B5	4	5	12	165	200	130	71	12	171	24	8	27.3
90/B14			9	115	140	95						
100/B5	4	5	15	215	250	180	82	12	182	28	8	31.3
100/B14		5.5	9	130	160	110						

DN172.01  
DN173.01

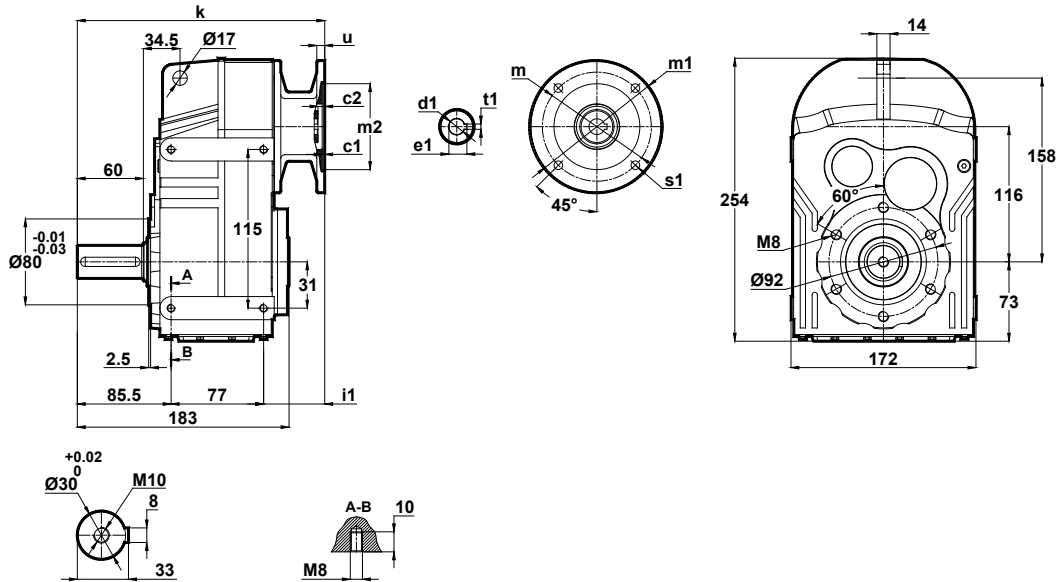

	c1	c2	s1	m	m1	m2(H7)	i1	u	k	d1	t1	e1
63/B5	4		10	115	140	95						
63/B14	2.5	5	5.5	75	90	60	55	10	217	11	4	12.8
71/B5	4	5	11	130	160	110	56	12	219	14	5	16.3
71/B14	3	4.5	7	85	105	70		10				
80/B5	4	5	12	165	200	130	71	12	234	19	6	21.8
80/B14			7	100	120	80						
90/B5	4	5	12	165	200	130	71	12	234	24	8	27.3
90/B14			9	115	140	95						
100/B5	4	5	15	215	250	180	82	12	245	28	8	31.3
100/B14		5.5	9	130	160	110						

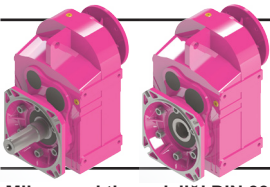

# Ölçü Sayfaları Dimension Pages Abmessungsseiten

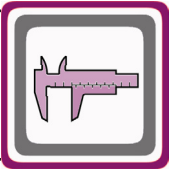

Mil ucu çektirme deliği DIN 332 sayfa 2 / Tapped center hole according to DIN 332, sheet 2 / Zentrierung mit Gewinde nach DIN 332, Blatt 2

DN172.02  
DN173.02

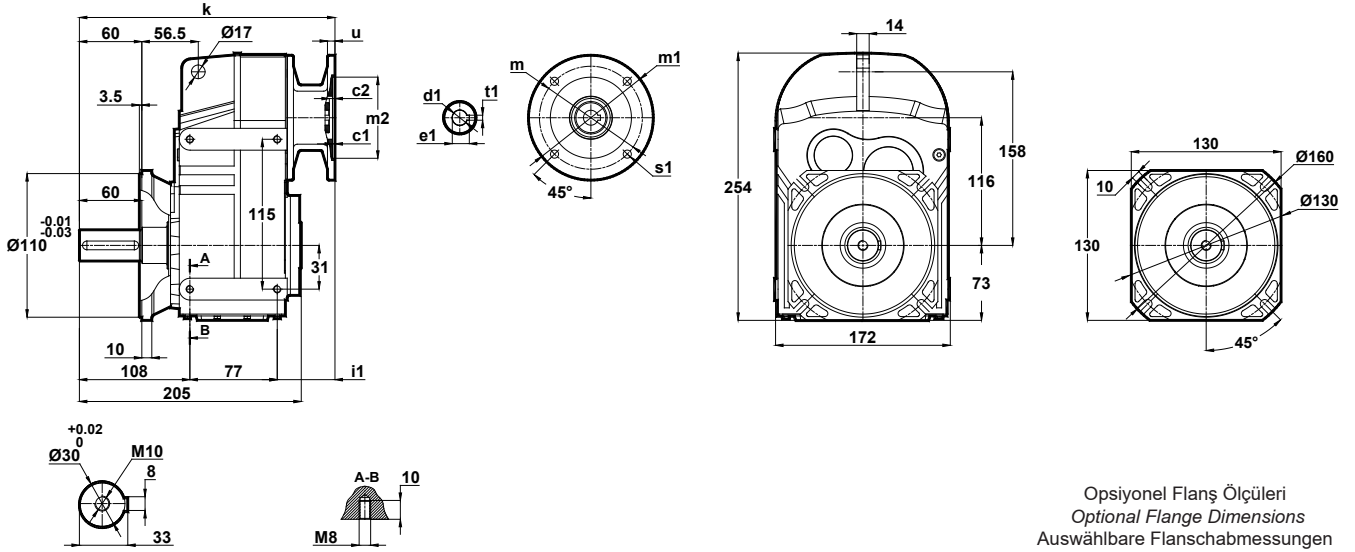

Opsiyonel Flanş Ölçüleri  
Optional Flange Dimensions  
Auswählbare Flanschabmessungen

	c1	c2	s1	m	m1	m2(H7)	i1	u	k	d1	t1	e1
63/B5	4	5	10	115	140	95	55	10	239	11	4	12.8
63/B14	2.5		5.5	75	90	60						
71/B5	4	5	11	130	160	110	56	12	241	14	5	16.3
71/B14	3	4.5	7	85	105	70		10				
80/B5	4	5	12	165	200	130	71	12	256	19	6	21.8
80/B14			7	100	120	80						
90/B5	4	5	12	165	200	130	71	12	256	24	8	27.3
90/B14			9	115	140	95						
100/B5	4	5	15	215	250	180	82	12	267	28	8	31.3
100/B14		5.5	9	130	160	110						

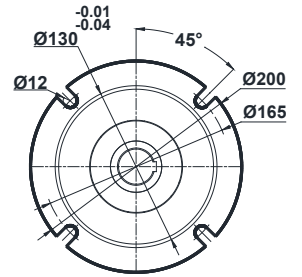

DN172.03  
DN173.03

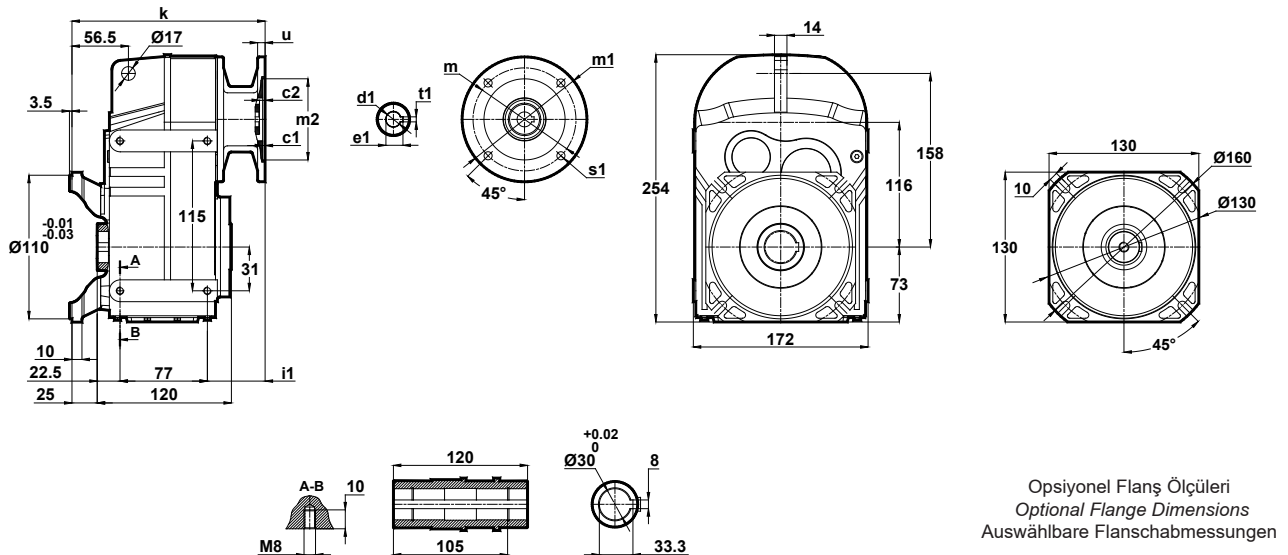

Opsiyonel Flanş Ölçüleri  
Optional Flange Dimensions  
Auswählbare Flanschabmessungen

	c1	c2	s1	m	m1	m2(H7)	i1	u	k	d1	t1	e1
63/B5	4	5	10	115	140	95	55	10	179	11	4	12.8
63/B14	2.5		5.5	75	90	60						
71/B5	4	5	11	130	160	110	56	12	181	14	5	16.3
71/B14	3	4.5	7	85	105	70		10				
80/B5	4	5	12	165	200	130	71	12	196	19	6	21.8
80/B14			7	100	120	80						
90/B5	4	5	12	165	200	130	71	12	196	24	8	27.3
90/B14			9	115	140	95						
100/B5	4	5	15	215	250	180	82	12	207	28	8	31.3
100/B14		5.5	9	130	160	110						

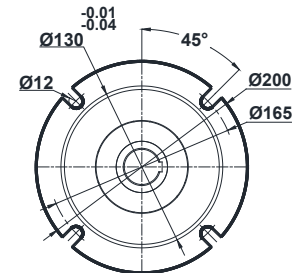

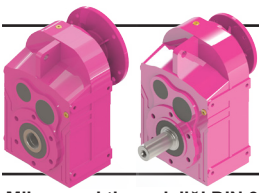

# Ölçü Sayfaları

## Dimension Pages

### Abmessungsseiten

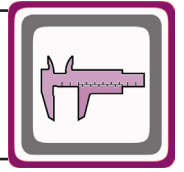

Mil ucu çekirme deliği DIN 332 sayfa 2 / Tapped center hole according to DIN 332, sheet 2 / Zentrierung mit Gewinde nach DIN 332, Blatt 2

DN272.00  
DN273.00

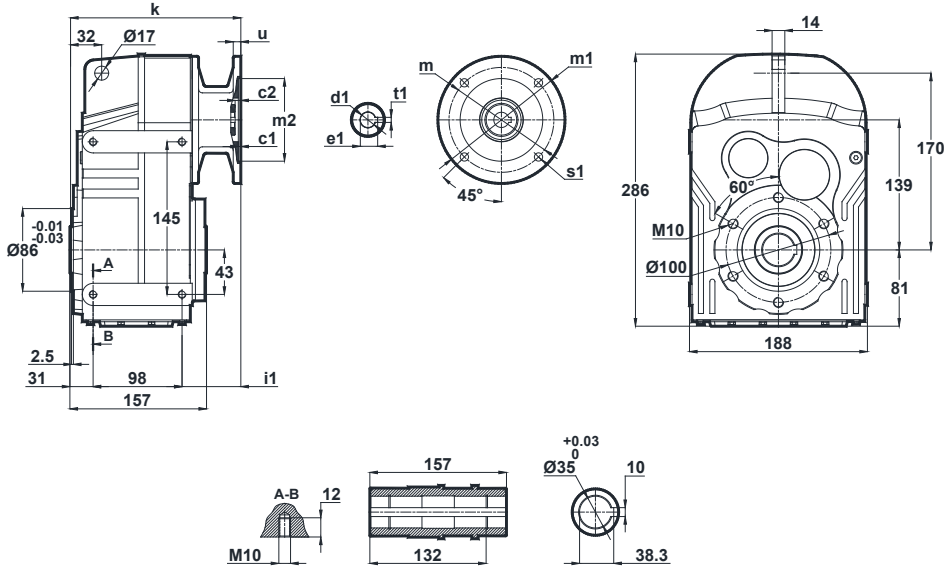

	c1	c2	s1	m	m1	m2(H7)	i1	u	k	d1	t1	e1
63/B5	4	5	10	115	140	95	55	10	184	11	4	12.8
63/B14	2.5	5	5.5	75	90	60	55	10	184	11	4	12.8
71/B5	4	5	11	130	160	110	56	12	186	14	5	16.3
71/B14	3	4.5	7	85	105	70	56	10	186	14	5	16.3
80/B5	4	5	12	165	200	130	71	12	201	19	6	21.8
80/B14	4	5	7	100	120	80	71	12	201	19	6	21.8
90/B5	4	5	12	165	200	130	71	12	201	24	8	27.3
90/B14	4	5	9	115	140	95	71	12	201	24	8	27.3
100/B5	4	5	15	215	250	180	82	12	212	28	8	31.3
100/B14	4	5.5	9	130	160	110	82	12	212	28	8	31.3

DN272.01  
DN273.01

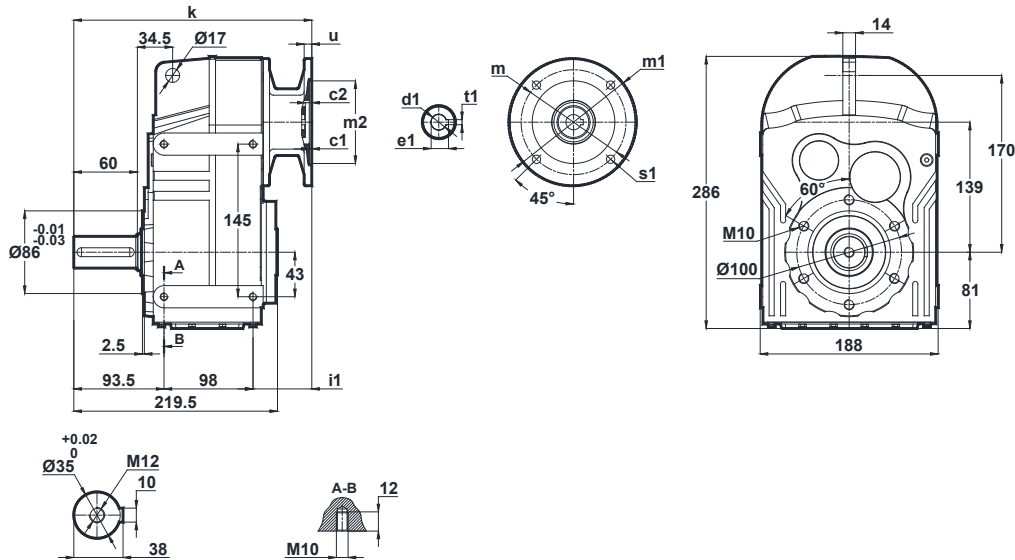

	c1	c2	s1	m	m1	m2(H7)	i1	u	k	d1	t1	e1
63/B5	4	5	10	115	140	95	55	10	246	11	4	12.8
63/B14	2.5	5	5.5	75	90	60	55	10	246	11	4	12.8
71/B5	4	5	11	130	160	110	56	12	248	14	5	16.3
71/B14	3	4.5	7	85	105	70	56	10	248	14	5	16.3
80/B5	4	5	12	165	200	130	71	12	263	19	6	21.8
80/B14	4	5	7	100	120	80	71	12	263	19	6	21.8
90/B5	4	5	12	165	200	130	71	12	263	24	8	27.3
90/B14	4	5	9	115	140	95	71	12	263	24	8	27.3
100/B5	4	5	15	215	250	180	82	12	273	28	8	31.3
100/B14	4	5.5	9	130	160	110	82	12	273	28	8	31.3

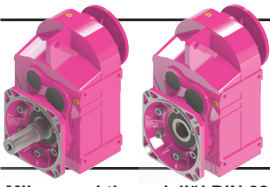

# Ölçü Sayfaları Dimension Pages Abmessungsseiten

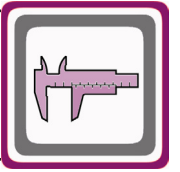

Mil ucu çektirme deliği DIN 332 sayfa 2 / Tapped center hole according to DIN 332, sheet 2 / Zentrierung mit Gewinde nach DIN 332, Blatt 2

DN272.02  
DN273.02

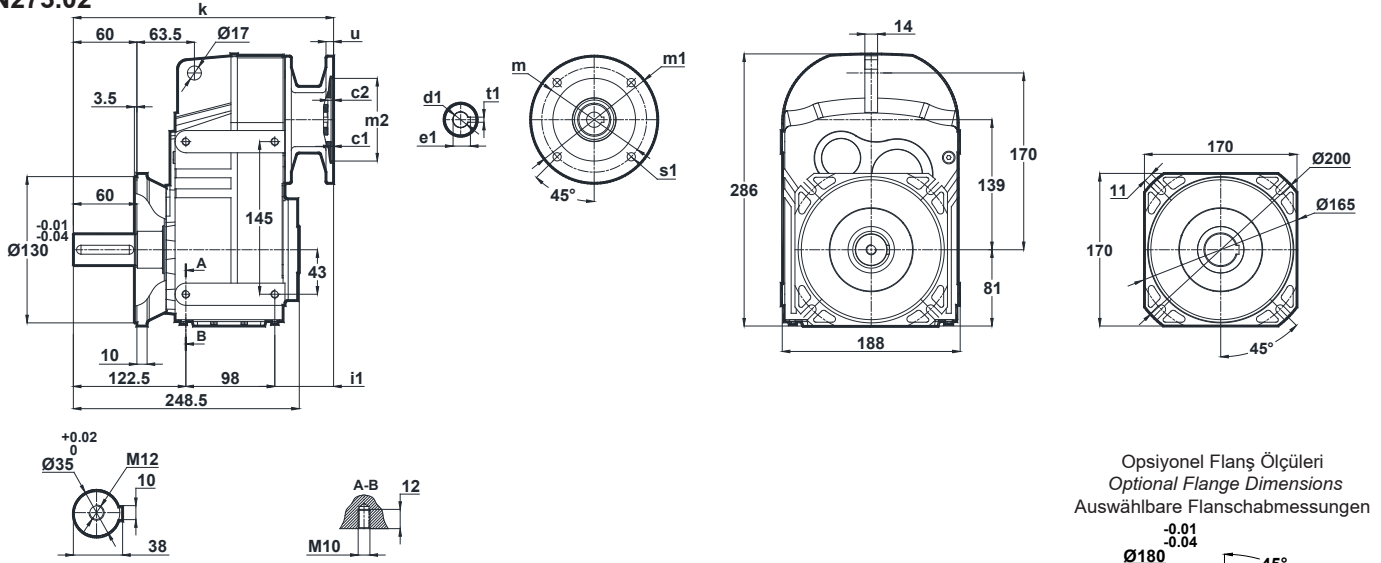

Opsiyonel Flanş Ölçüleri  
Optional Flange Dimensions  
Auswählbare Flanschabmessungen

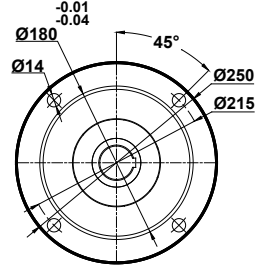

	c1	c2	s1	m	m1	m2(H7)	i1	u	k	d1	t1	e1
63/B5	4	5	10	115	140	95	55	10	275	11	4	12.8
63/B14	2.5	5	5.5	75	90	60						
71/B5	4	5	11	130	160	110	56	12	277	14	5	16.3
71/B14	3	4.5	7	85	105	70						
80/B5	4	5	12	165	200	130	71	12	292	19	6	21.8
80/B14			7	100	120	80						
90/B5	4	5	12	165	200	130	71	12	292	24	8	27.3
90/B14			9	115	140	95						
100/B5	4	5	15	215	250	180	82	12	303	28	8	31.3
100/B14		5.5	9	130	160	110						

DN272.03  
DN273.03

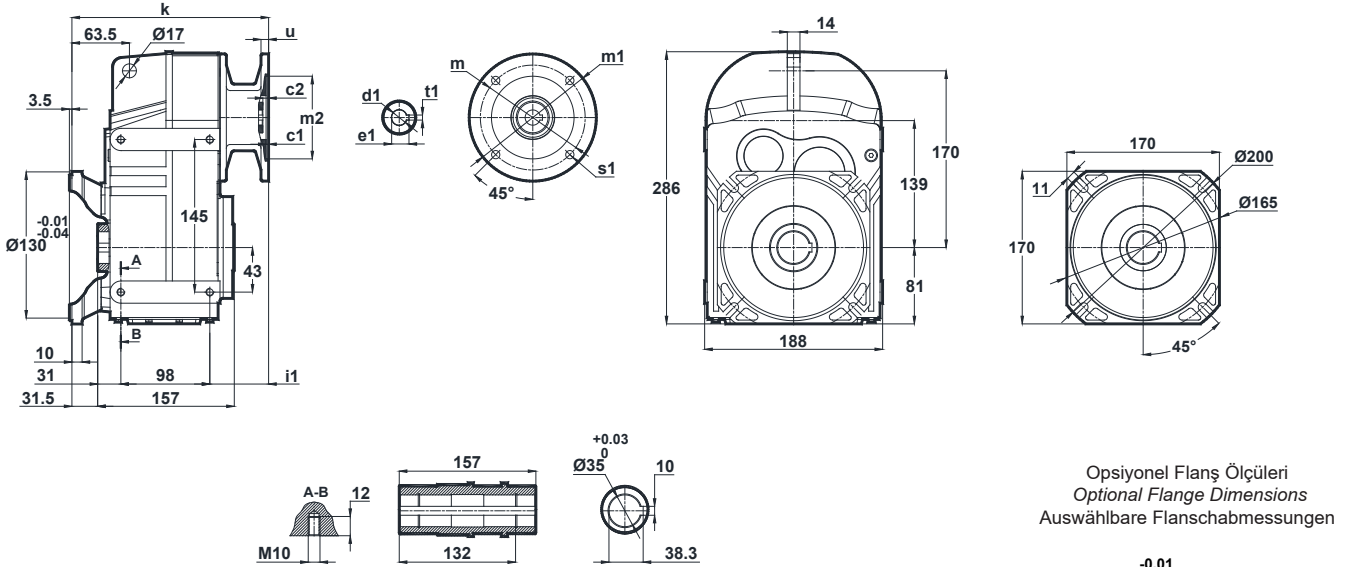

Opsiyonel Flanş Ölçüleri  
Optional Flange Dimensions  
Auswählbare Flanschabmessungen

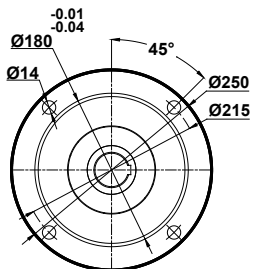

	c1	c2	s1	m	m1	m2(H7)	i1	u	k	d1	t1	e1
63/B5	4	5	10	115	140	95	55	10	215	11	4	12.8
63/B14	2.5	5	5.5	75	90	60						
71/B5	4	5	11	130	160	110	56	12	217	14	5	16.3
71/B14	3	4.5	7	85	105	70						
80/B5	4	5	12	165	200	130	71	12	232	19	6	21.8
80/B14			7	100	120	80						
90/B5	4	5	12	165	200	130	71	12	232	24	8	27.3
90/B14			9	115	140	95						
100/B5	4	5	15	215	250	180	82	12	243	28	8	31.3
100/B14		5.5	9	130	160	110						

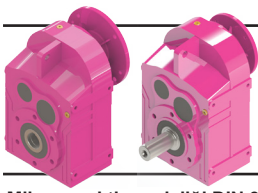

# Ölçü Sayfaları

## Dimension Pages

### Abmessungenseiten

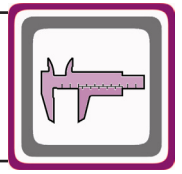

Mil ucu çekirtme deliği DIN 332 sayfa 2 / Tapped center hole according to DIN 332, sheet 2 / Zentrierung mit Gewinde nach DIN 332, Blatt 2

DN275.00  
DN276.00

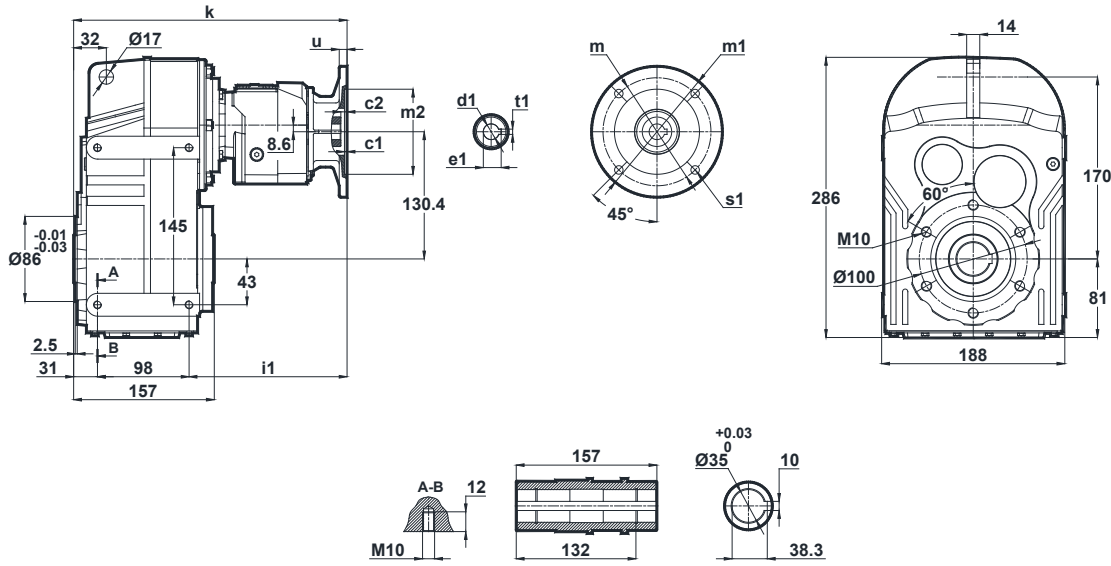

	c1	c2	s1	m	m1	m2(H7)	i1	u	k	d1	t1	e1
63/B5	4	5	10	115	140	95	55	10	333	11	4	12.8
63/B14	2.5	5	5.5	75	90	60	55	10	333	11	4	12.8
71/B5	4	5	11	130	160	110	56	12	335	14	5	16.3
71/B14	3	4.5	7	85	105	70	56	10	335	14	5	16.3

DN275.01  
DN276.01

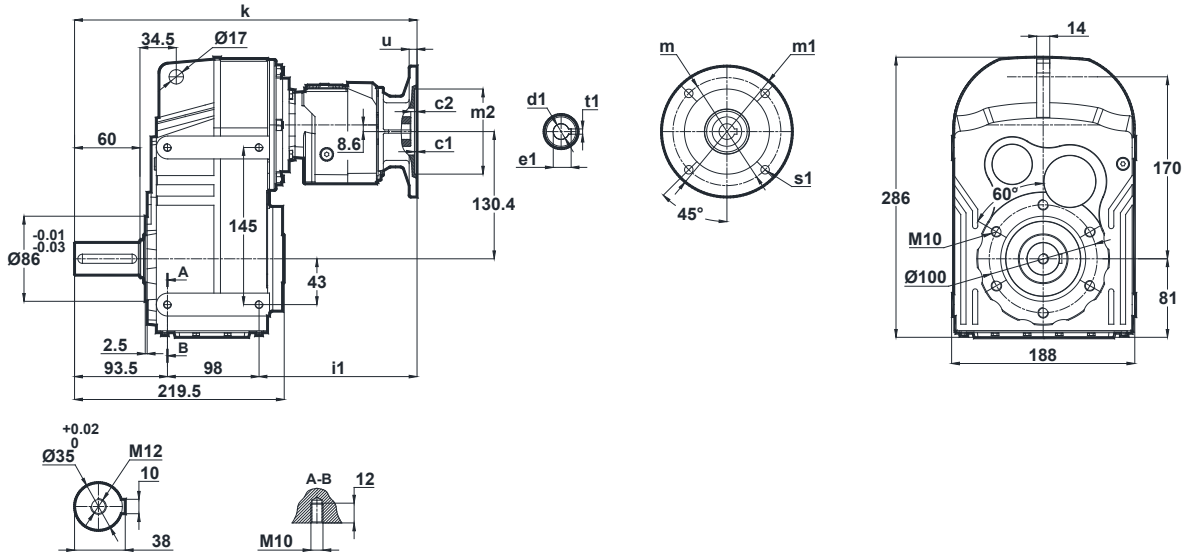

	c1	c2	s1	m	m1	m2(H7)	i1	u	k	d1	t1	e1
63/B5	4	5	10	115	140	95	55	10	395	11	4	12.8
63/B14	2.5	5	5.5	75	90	60	55	10	395	11	4	12.8
71/B5	4	5	11	130	160	110	56	12	397	14	5	16.3
71/B14	3	4.5	7	85	105	70	56	10	397	14	5	16.3

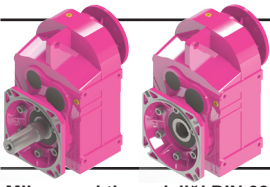

# Ölçü Sayfaları Dimension Pages Abmessungsseiten

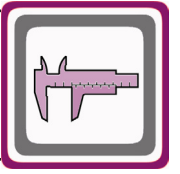

Mil ucu çektirme deliği DIN 332 sayfa 2 / Tapped center hole according to DIN 332, sheet 2 / Zentrierung mit Gewinde nach DIN 332, Blatt 2

DN275.02  
DN276.02

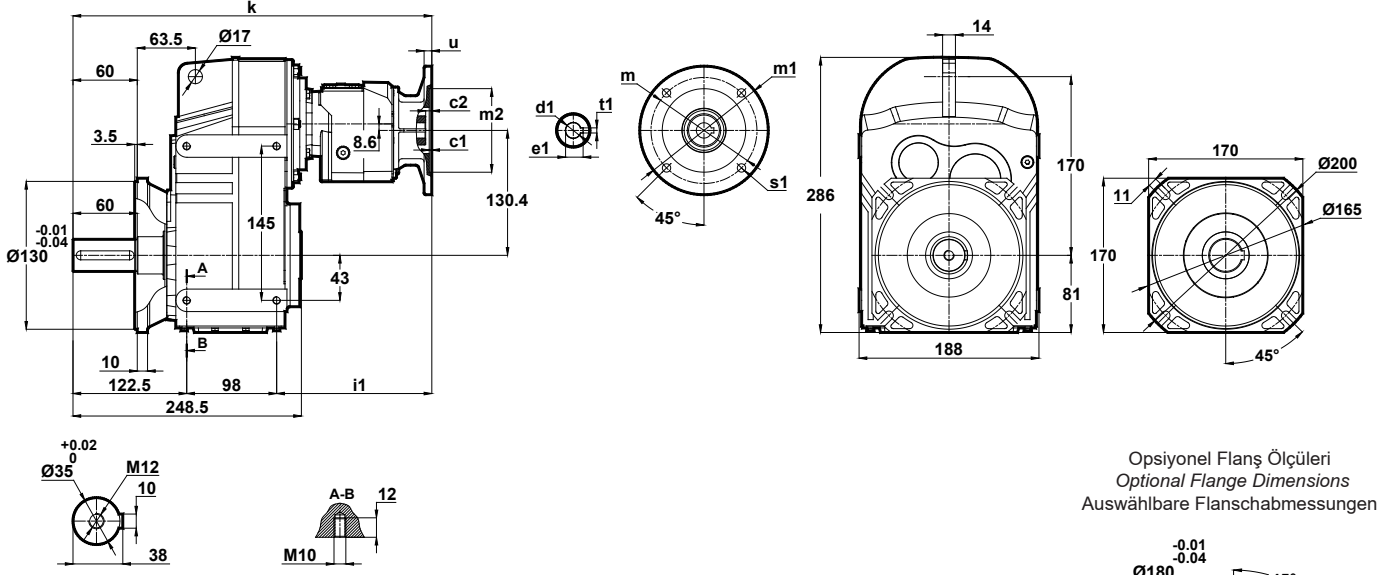

Opsiyonel Flanş Ölçüleri  
Optional Flange Dimensions  
Auswählbare Flanschabmessungen

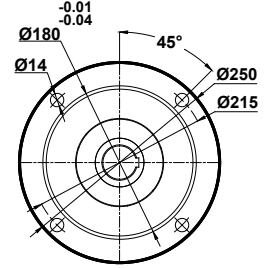

	c1	c2	s1	m	m1	m2(H7)	i1	u	k	d1	t1	e1
63/B5	4	5	10	115	140	95	55	10	424	11	4	12.8
63/B14	2.5	5	5.5	75	90	60	55	10	424	11	4	12.8
71/B5	4	5	11	130	160	110	56	12	426	14	5	16.3
71/B14	3	4.5	7	85	105	70	56	10	426	14	5	16.3

DN275.03  
DN276.03

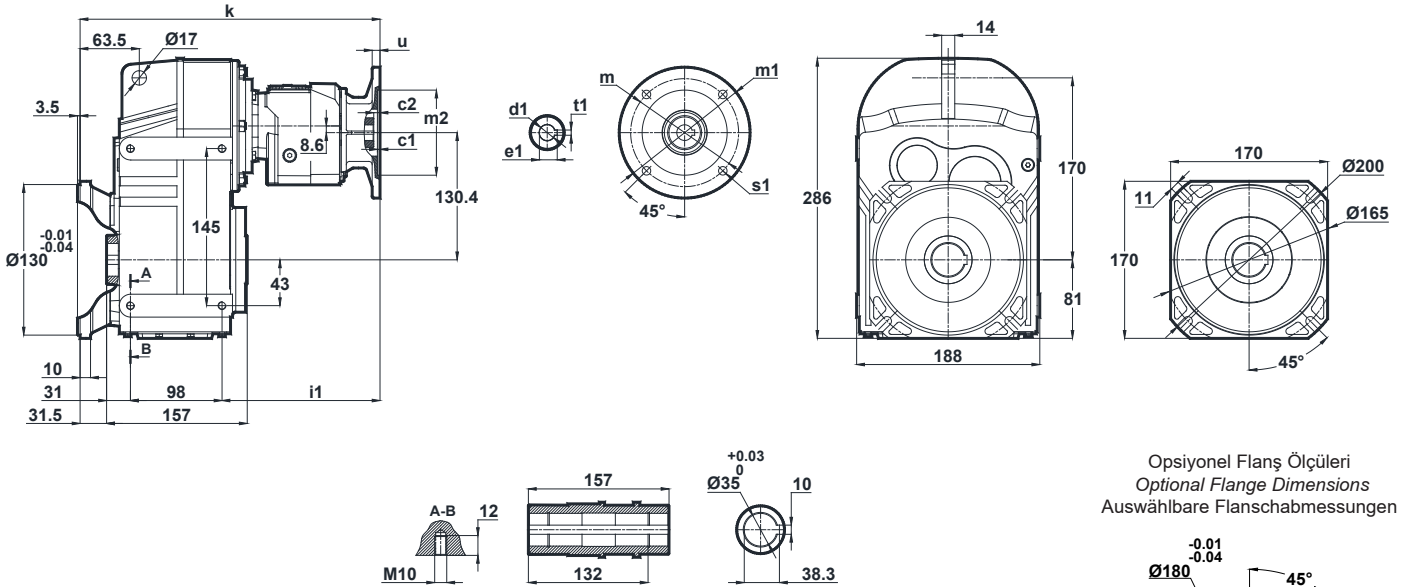

Opsiyonel Flanş Ölçüleri  
Optional Flange Dimensions  
Auswählbare Flanschabmessungen

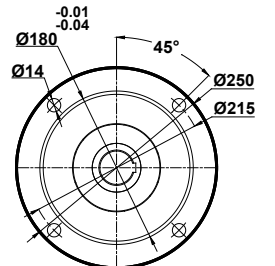

	c1	c2	s1	m	m1	m2(H7)	i1	u	k	d1	t1	e1
63/B5	4	5	10	115	140	95	55	10	364	11	4	12.8
63/B14	2.5	5	5.5	75	90	60	55	10	364	11	4	12.8
71/B5	4	5	11	130	160	110	56	12	366	14	5	16.3
71/B14	3	4.5	7	85	105	70	56	10	366	14	5	16.3

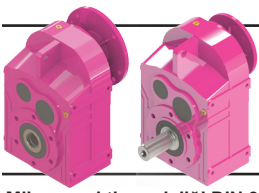

# Ölçü Sayfaları

## Dimension Pages

### Abmessungsseiten

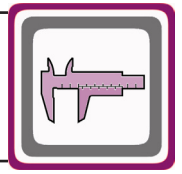

Mil ucu çekirtme deliği DIN 332 sayfa 2 / Tapped center hole according to DIN 332, sheet 2 / Zentrierung mit Gewinde nach DIN 332, Blatt 2

DN282.00  
DN283.00

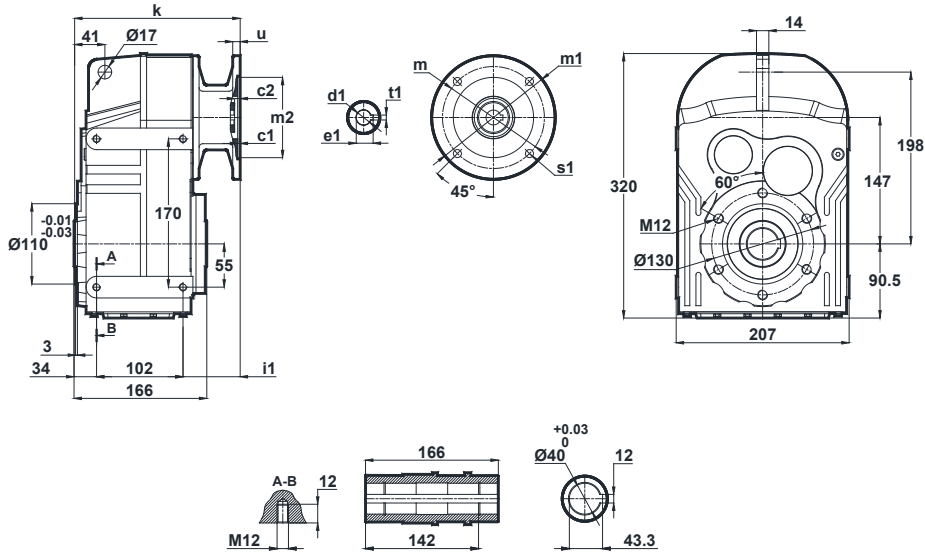

	c1	c2	s1	m	m1	m2(H7)	i1	u	k	d1	t1	e1
63/B5	4	8	9	115	140	95	87	12	223	11	4	12.8
71/B5	4	9	11	130	160	110	58	12	194	14	5	16.3
71/B14	3	8.5	7	85	105	70		10				
80/B5	4	5	12	165	200	130	87	12	223	19	6	21.8
80/B14			7	100	120	80						
90/B5	4	5	12	165	200	130	87	12	223	24	8	27.3
90/B14			9	115	140	95						
100/B5	4	6	15	215	250	180	80	12	216	28	8	31.3
100/B14		5.5	9	130	160	110						
112/B5	4	6	15	215	250	180	80	12	216	28	8	31.3
112/B14		5.5	9	130	160	110						
132/B5	4.5	7	15	265	300	230	127	15	259	38	10	41.3
132/B14		9	11	165	200	130						

DN282.01  
DN283.01

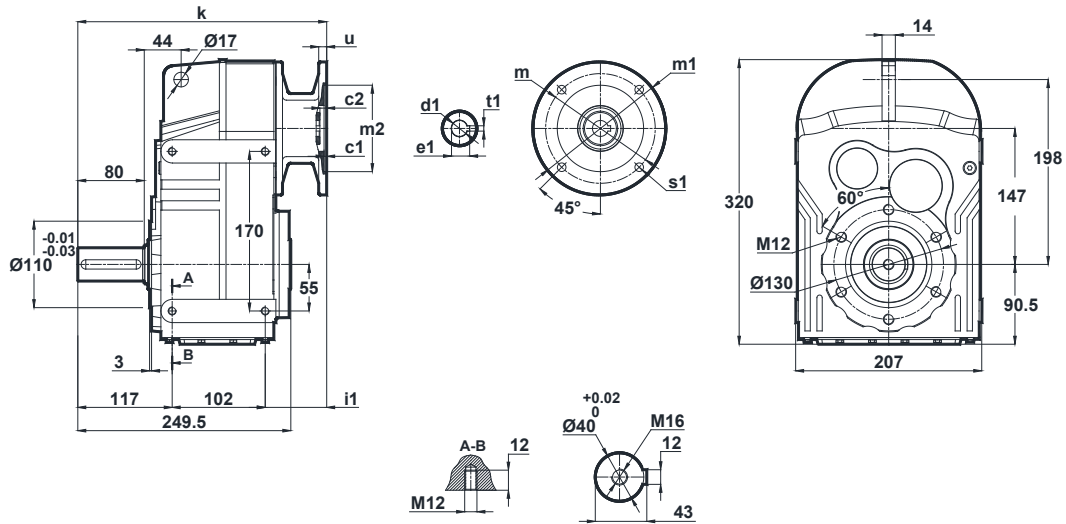

	c1	c2	s1	m	m1	m2(H7)	i1	u	k	d1	t1	e1
63/B5	4	8	9	115	140	95	87	12	307	11	4	12.8
71/B5	4	9	11	130	160	110	58	12	278	14	5	16.3
71/B14	3	8.5	7	85	105	70		10				
80/B5	4	5	12	165	200	130	87	12	307	19	6	21.8
80/B14			7	100	120	80						
90/B5	4	5	12	165	200	130	87	12	307	24	8	27.3
90/B14			9	115	140	95						
100/B5	4	6	15	215	250	180	80	12	300	28	8	31.3
100/B14		5.5	9	130	160	110						
112/B5	4	6	15	215	250	180	80	12	300	28	8	31.3
112/B14		5.5	9	130	160	110						
132/B5	4.5	7	15	265	300	230	127	15	343	38	10	41.3
132/B14		9	11	165	200	130						

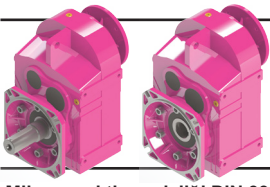

# Ölçü Sayfaları Dimension Pages Abmessungsseiten

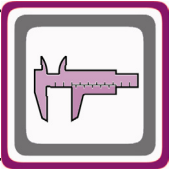

Mil ucu çektirme deliği DIN 332 sayfa 2 / Tapped center hole according to DIN 332, sheet 2 / Zentrierung mit Gewinde nach DIN 332, Blatt 2

DN282.02  
DN283.02

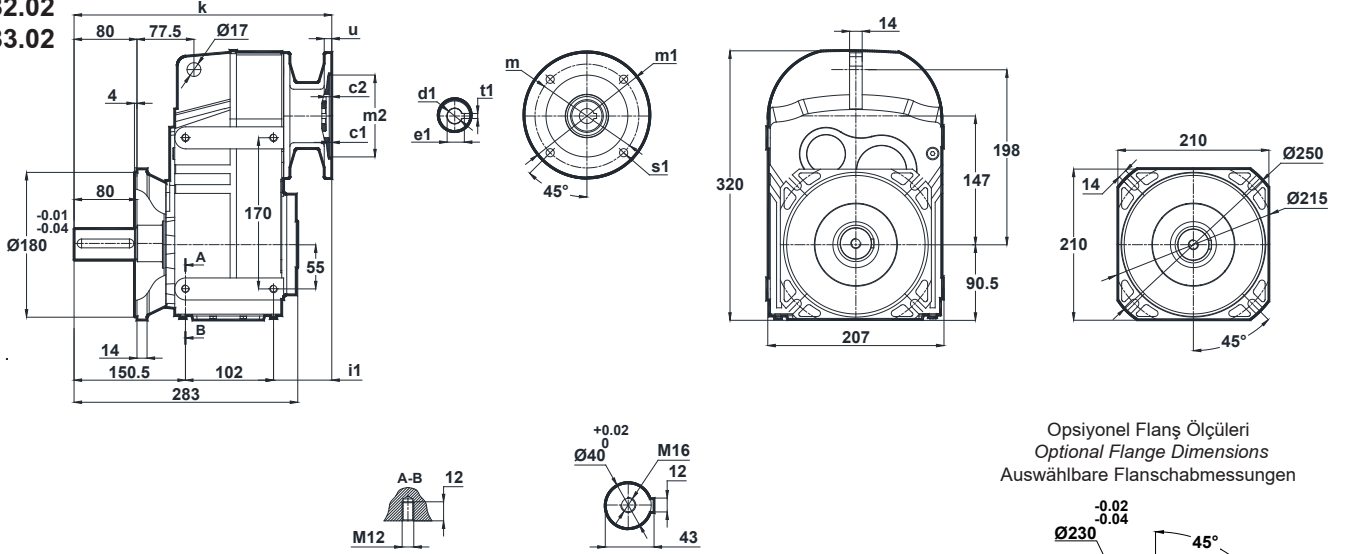

Opsiyonel Flanş Ölçüleri  
Optional Flange Dimensions  
Auswählbare Flanschabmessungen

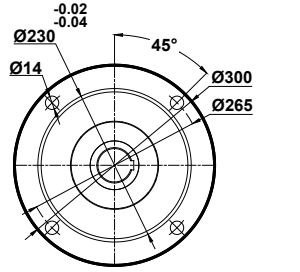

Diğer opsiyonel flanş ölçüleri için sayfa 326'ya bakınız.  
Please see on page 326 for other optional flange dimensions  
Siehe Seite 326 für andere auswählbare Flanschabmessungen

	c1	c2	s1	m	m1	m2(H7)	i1	u	k	d1	t1	e1
63/B5	4	8	9	115	140	95	87	12	340	11	4	12.8
71/B5	4	9	11	130	160	110	58	12	311	14	5	16.3
71/B14	3	8.5	7	85	105	70	58	10	311	14	5	16.3
80/B5	4	5	12	165	200	130	87	12	340	19	6	21.8
80/B14	4	5	7	100	120	80	87	12	340	24	8	27.3
90/B5	4	5	12	165	200	130	87	12	340	24	8	27.3
90/B14	4	5	9	115	140	95	87	12	340	24	8	27.3
100/B5	4	6	15	215	250	180	80	12	333	28	8	31.3
100/B14	4	5.5	9	130	160	110	80	12	333	28	8	31.3
112/B5	4	6	15	215	250	180	80	12	333	28	8	31.3
112/B14	4	5.5	9	130	160	110	80	12	333	28	8	31.3
132/B5	4.5	7	15	265	300	230	127	15	376	38	10	41.3
132/B14	4.5	9	11	165	200	130	127	15	376	38	10	41.3

DN282.03  
DN283.03

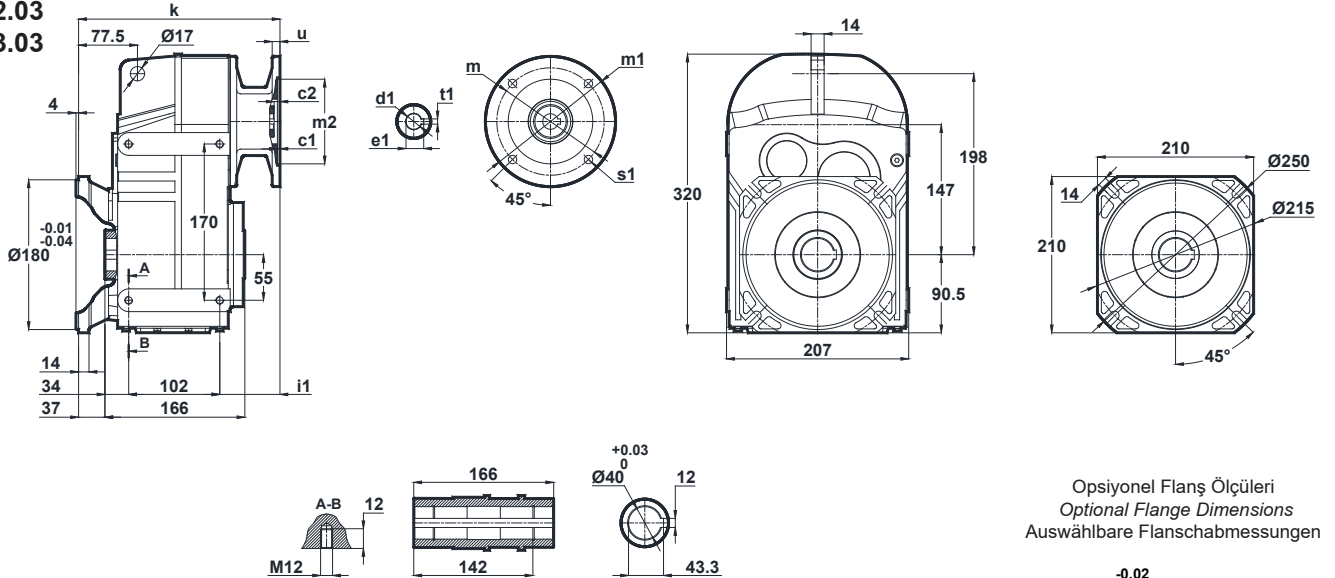

Opsiyonel Flanş Ölçüleri  
Optional Flange Dimensions  
Auswählbare Flanschabmessungen

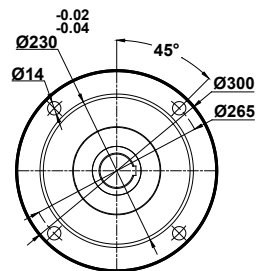

Diğer opsiyonel flanş ölçüleri için sayfa 326'ya bakınız.  
Please see on page 326 for other optional flange dimensions  
Siehe Seite 326 für andere auswählbare Flanschabmessungen

	c1	c2	s1	m	m1	m2(H7)	i1	u	k	d1	t1	e1
63/B5	4	8	9	115	140	95	87	12	260	11	4	12.8
71/B5	4	9	11	130	160	110	58	12	231	14	5	16.3
71/B14	3	8.5	7	85	105	70	58	10	231	14	5	16.3
80/B5	4	5	12	165	200	130	87	12	260	19	6	21.8
80/B14	4	5	7	100	120	80	87	12	260	24	8	27.3
90/B5	4	5	12	165	200	130	87	12	260	24	8	27.3
90/B14	4	5	9	115	140	95	87	12	260	24	8	27.3
100/B5	4	6	15	215	250	180	80	12	253	28	8	31.3
100/B14	4	5.5	9	130	160	110	80	12	253	28	8	31.3
112/B5	4	6	15	215	250	180	80	12	253	28	8	31.3
112/B14	4	5.5	9	130	160	110	80	12	253	28	8	31.3
132/B5	4.5	7	15	265	300	230	127	15	296	38	10	41.3
132/B14	4.5	9	11	165	200	130	127	15	296	38	10	41.3

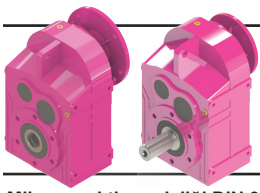

# Ölçü Sayfaları

## Dimension Pages

### Abmessungsseiten

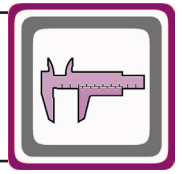

Mil ucu çekirtme deliği DIN 332 sayfa 2 / Tapped center hole according to DIN 332, sheet 2 / Zentrierung mit Gewinde nach DIN 332, Blatt 2

DN285.00  
DN286.00

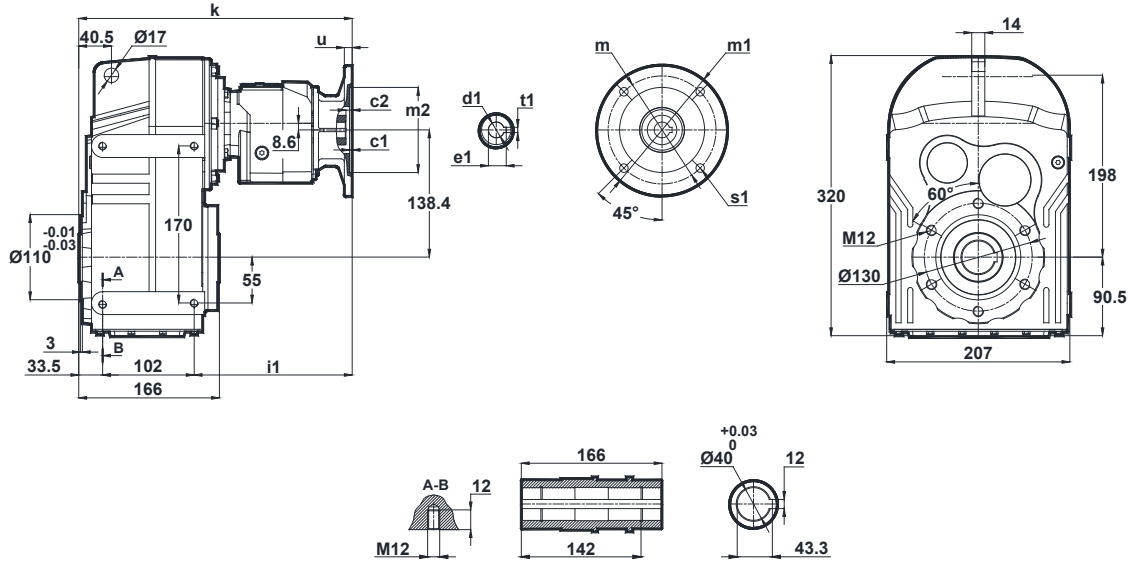

	c1	c2	s1	m	m1	m2(H7)	i1	u	k	d1	t1	e1
63/B5	4		10	115	140	95						
63/B14	2.5	5	5.5	75	90	60	203	10	338	11	4	12.8
71/B5	4	5	11	130	160	110						
71/B14	3	4.5	7	85	105	70	204	10	340	14	5	16.3

DN285.01  
DN286.01

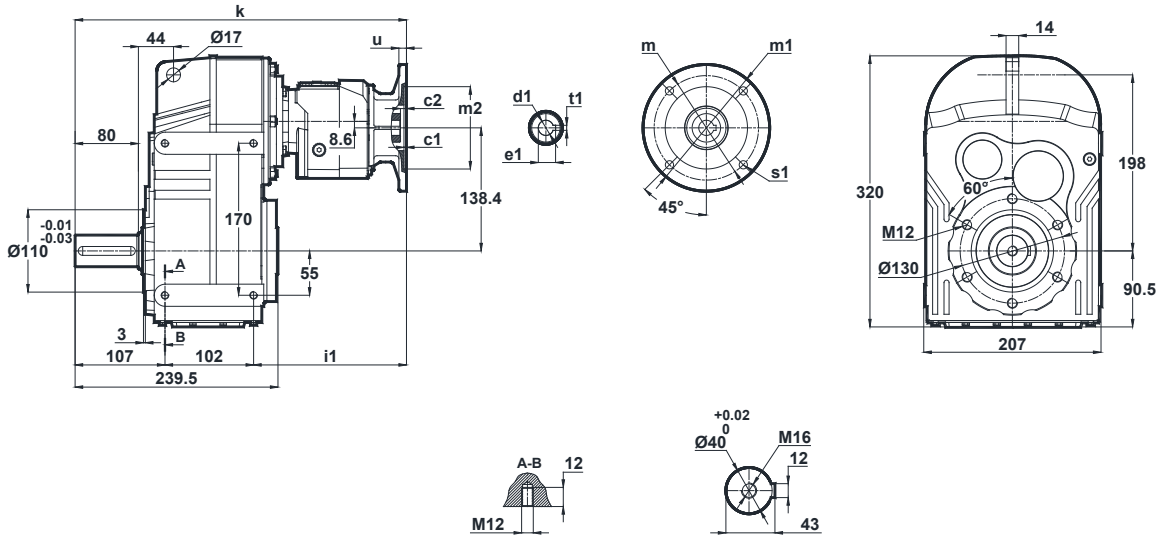

	c1	c2	s1	m	m1	m2(H7)	i1	u	k	d1	t1	e1
63/B5	4		10	115	140	95						
63/B14	2.5	5	5.5	75	90	60	203	10	422	11	4	12.8
71/B5	4	5	11	130	160	110						
71/B14	3	4.5	7	85	105	70	204	10	424	14	5	16.3

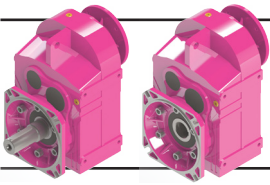

# Ölçü Sayfaları Dimension Pages Abmessungsseiten

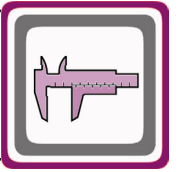

Mil ucu çektirme deliği DIN 332 sayfa 2 / Tapped center hole according to DIN 332, sheet 2 / Zentrierung mit Gewinde nach DIN 332, Blatt 2

DN285.02  
DN286.02

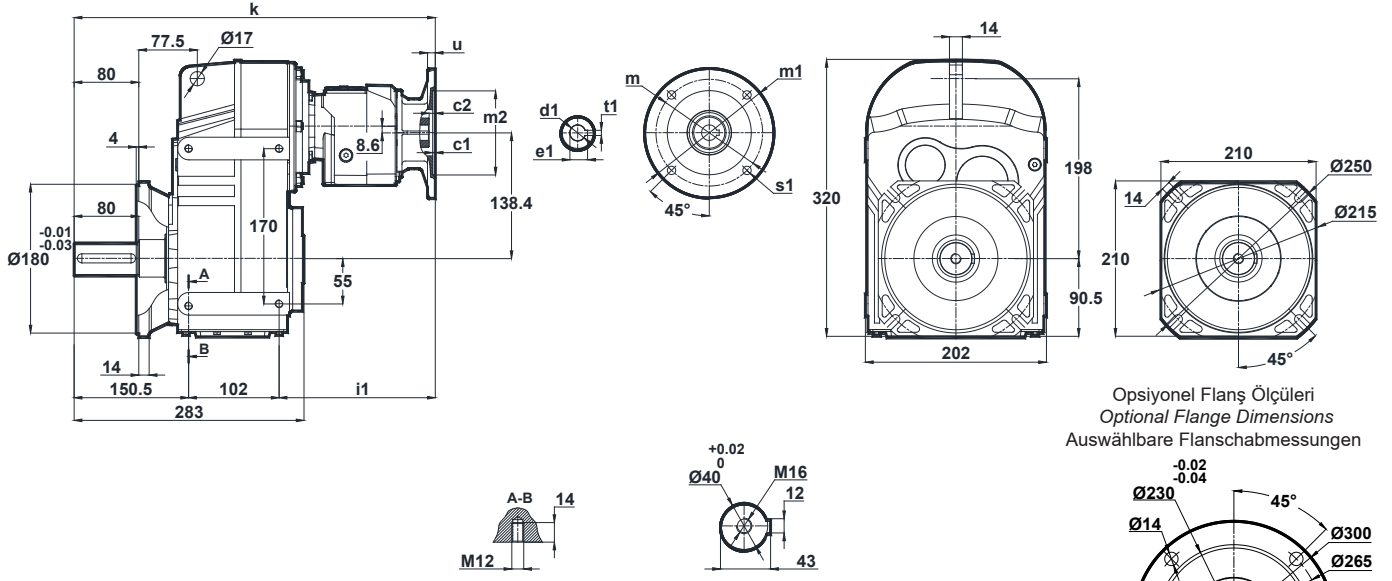

Opsiyonel Flanş Ölçüleri  
Optional Flange Dimensions  
Auswählbare Flanschabmessungen

	c1	c2	s1	m	m1	m2(H7)	i1	u	k	d1	t1	e1
63/B5	4	5	10	115	140	95	203	10	455	11	4	12.8
63/B14	2.5	5	5.5	75	90	60	203	10	455	11	4	12.8
71/B5	4	5	11	130	160	110	204	12	457	14	5	16.3
71/B14	3	4.5	7	85	105	70	204	10	457	14	5	16.3

Diğer opsiyonel flanş ölçüleri için sayfa 326'ya bakınız.  
Please see on page 326 for other optional flange dimensions  
Siehe Seite 326 für andere auswählbare Flanschabmessungen

DN285.03  
DN286.03

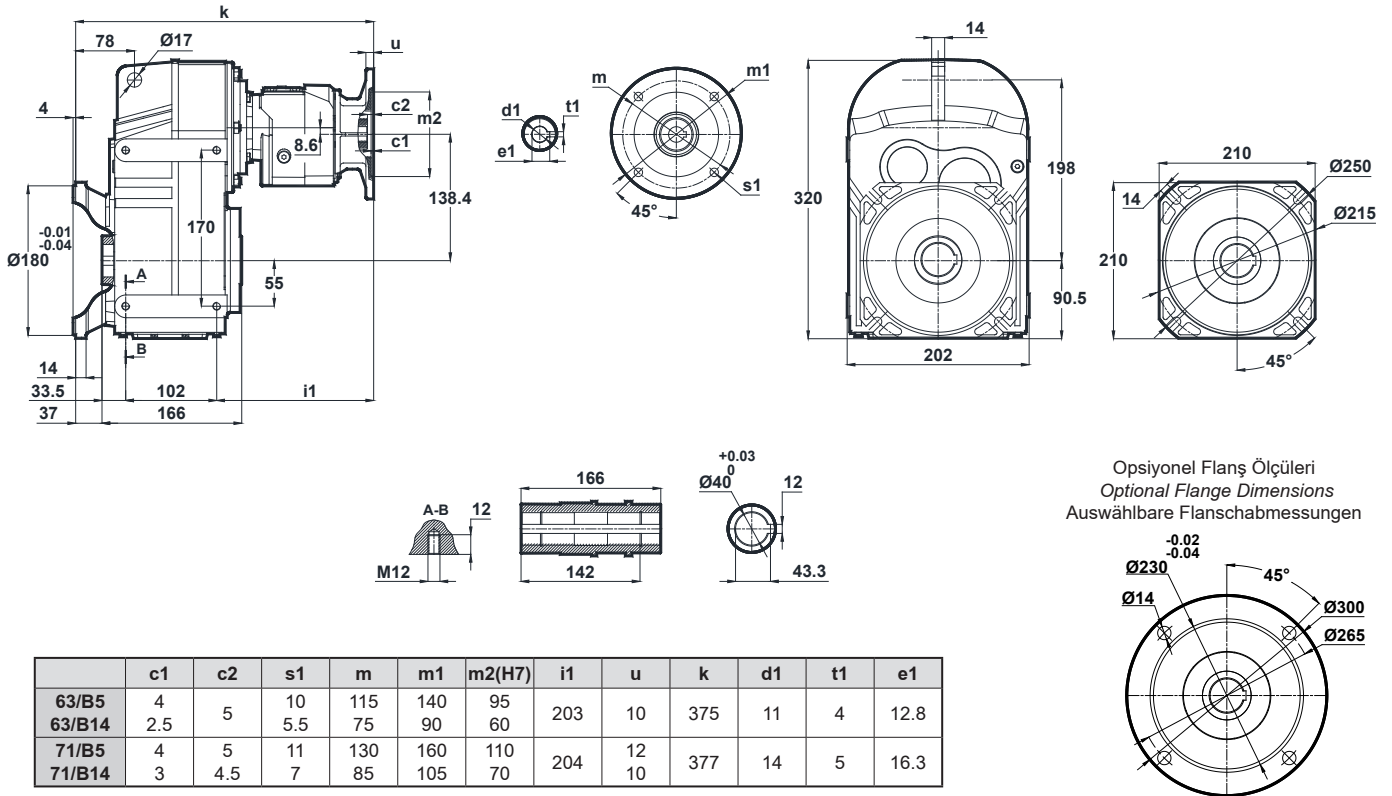

Opsiyonel Flanş Ölçüleri  
Optional Flange Dimensions  
Auswählbare Flanschabmessungen

	c1	c2	s1	m	m1	m2(H7)	i1	u	k	d1	t1	e1
63/B5	4	5	10	115	140	95	203	10	375	11	4	12.8
63/B14	2.5	5	5.5	75	90	60	203	10	375	11	4	12.8
71/B5	4	5	11	130	160	110	204	12	377	14	5	16.3
71/B14	3	4.5	7	85	105	70	204	10	377	14	5	16.3

Diğer opsiyonel flanş ölçüleri için sayfa 326'ya bakınız.  
Please see on page 326 for other optional flange dimensions  
Siehe Seite 326 für andere auswählbare Flanschabmessungen

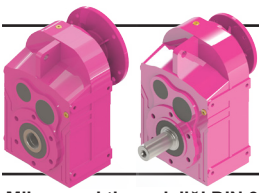

# Ölçü Sayfaları

## Dimension Pages

### Abmessungsseiten

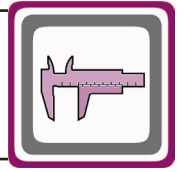

Mil ucu çekirme deliği DIN 332 sayfa 2 / Tapped center hole according to DIN 332, sheet 2 / Zentrierung mit Gewinde nach DIN 332, Blatt 2

DN372.00  
DN373.00

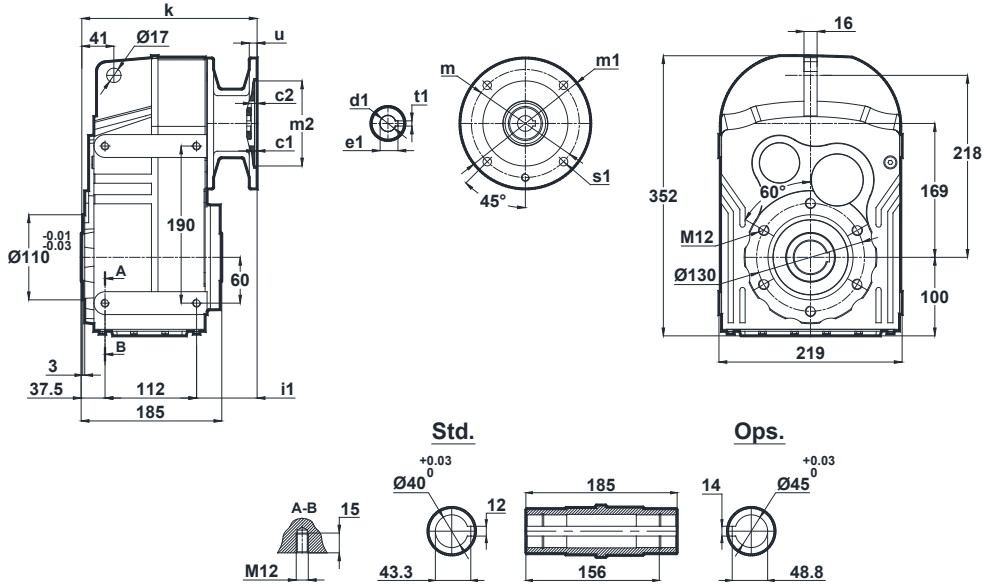

	c1	c2	s1	m	m1	m2(H7)	i1	u	k	d1	t1	e1
71/B5	4	9	11	130	160	110	84	12	205	14	5	16.3
71/B14	3	8.5	7	85	105	70	84	10	10	14	5	16.3
80/B5	4	5	12	165	200	130	84	12	234	19	6	21.8
80/B14	4	5	7	100	120	80	84	12	10	19	6	21.8
90/B5	4	5	12	165	200	130	84	12	234	24	8	27.3
90/B14	4	5	9	115	140	95	84	12	10	24	8	27.3
100/B5	4	6	15	215	250	180	77	12	227	28	8	31.3
100/B14	4	5.5	9	130	160	110	77	12	10	28	8	31.3
112/B5	4	6	15	215	250	180	77	12	227	28	8	31.3
112/B14	4	5.5	9	130	160	110	77	12	10	28	8	31.3
132/B5	4.5	7	15	265	300	230	124	15	270	38	10	41.3
132/B14	4.5	9	11	165	200	130	124	15	10	38	10	41.3

DN372.01  
DN373.01

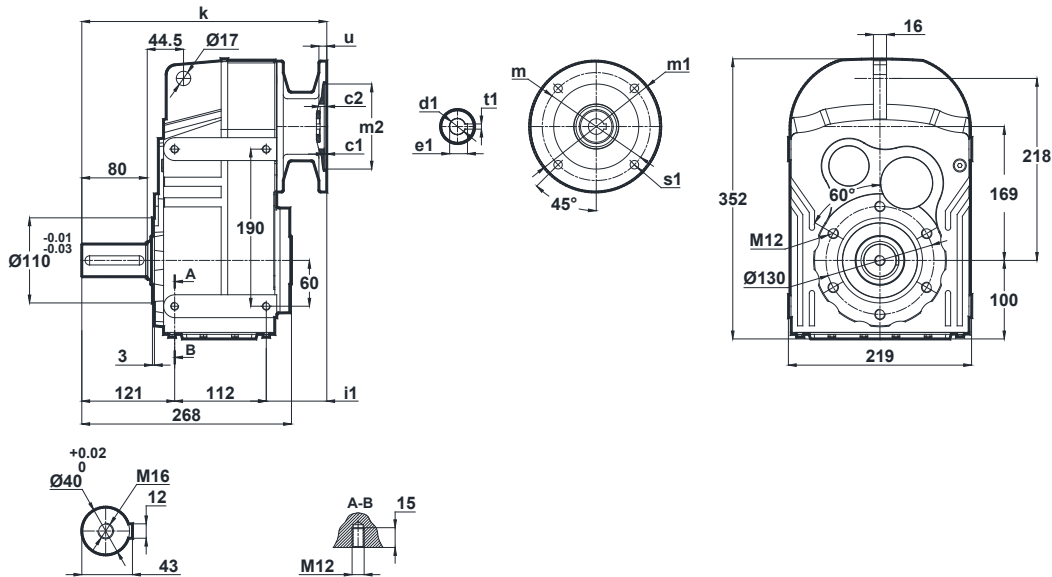

	c1	c2	s1	m	m1	m2(H7)	i1	u	k	d1	t1	e1
71/B5	4	9	11	130	160	110	84	12	288	14	5	16.3
71/B14	3	8.5	7	85	105	70	84	10	10	14	5	16.3
80/B5	4	5	12	165	200	130	84	12	317	19	6	21.8
80/B14	4	5	7	100	120	80	84	12	10	19	6	21.8
90/B5	4	5	12	165	200	130	84	12	317	24	8	27.3
90/B14	4	5	9	115	140	95	84	12	10	24	8	27.3
100/B5	4	6	15	215	250	180	77	12	310	28	8	31.3
100/B14	4	5.5	9	130	160	110	77	12	10	28	8	31.3
112/B5	4	6	15	215	250	180	77	12	310	28	8	31.3
112/B14	4	5.5	9	130	160	110	77	12	10	28	8	31.3
132/B5	4.5	7	15	265	300	230	124	15	353	38	10	41.3
132/B14	4.5	9	11	165	200	130	124	15	10	38	10	41.3

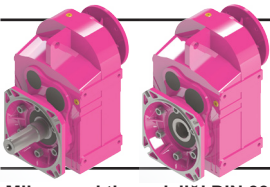

# Ölçü Sayfaları Dimension Pages Abmessungsseiten

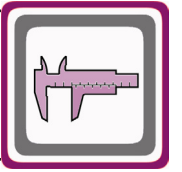

Mil ucu çektirme deliği DIN 332 sayfa 2 / Tapped center hole according to DIN 332, sheet 2 / Zentrierung mit Gewinde nach DIN 332, Blatt 2

DN372.02  
DN373.02

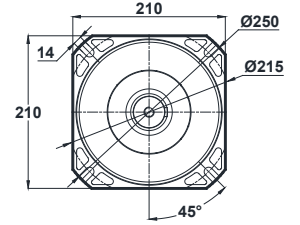
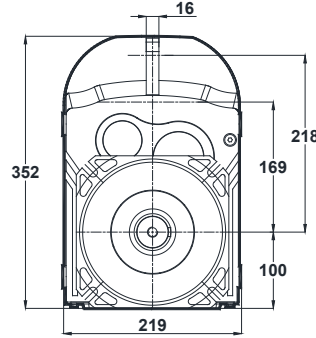
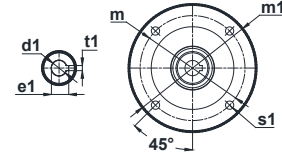
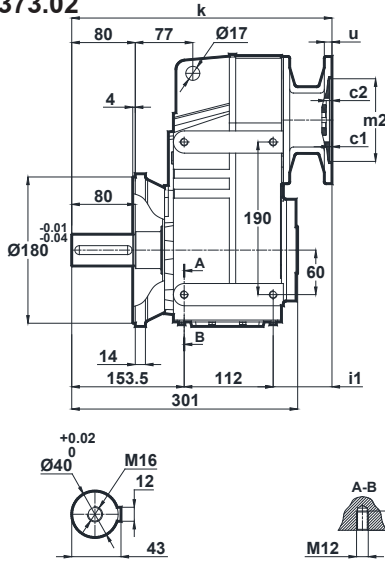

Opsiyonel Flanş Ölçüleri  
Optional Flange Dimensions  
Auswählbare Flanschabmessungen

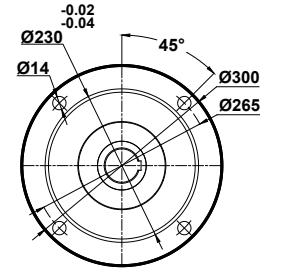

Diğer opsiyonel flanş ölçüleri için sayfa 326'ya bakınız.  
Please see on page 326 for other optional flange dimensions  
Siehe Seite 326 für andere auswählbare Flanschabmessungen

	c1	c2	s1	m	m1	m2(H7)	i1	u	k	d1	t1	e1
71/B5	4	9	11	130	160	110	84	12	311	14	5	16.3
71/B14	3	8.5	7	85	105	70						
80/B5	4	5	12	165	200	130	84	12	340	19	6	21.8
80/B14			7	100	120	80						
90/B5	4	5	12	165	200	130	84	12	340	24	8	27.3
90/B14			9	115	140	95						
100/B5	4	6	15	215	250	180	77	12	333	28	8	31.3
100/B14		5.5	9	130	160	110						
112/B5	4	6	15	215	250	180	77	12	333	28	8	31.3
112/B14		5.5	9	130	160	110						
132/B5	4.5	7	15	265	300	230	124	15	376	38	10	41.3

DN372.03  
DN373.03

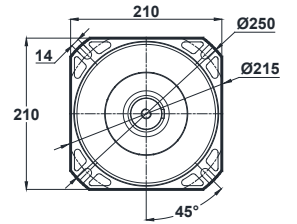
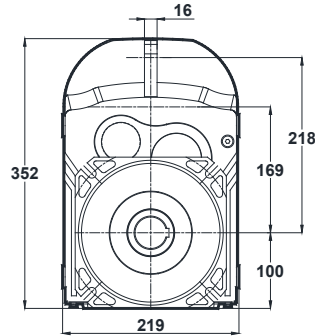
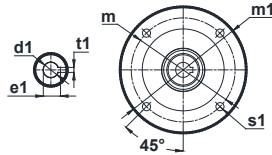
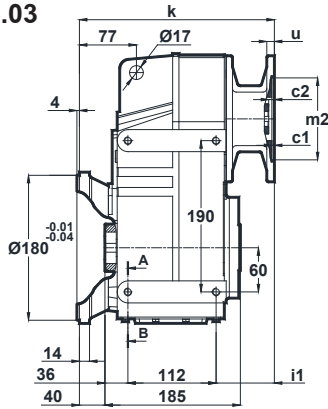

Opsiyonel Flanş Ölçüleri  
Optional Flange Dimensions  
Auswählbare Flanschabmessungen

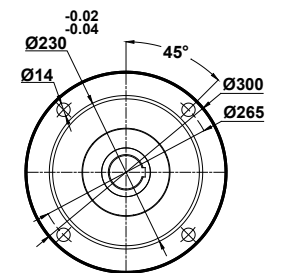

Diğer opsiyonel flanş ölçüleri için sayfa 326'ya bakınız.  
Please see on page 326 for other optional flange dimensions  
Siehe Seite 326 für andere auswählbare Flanschabmessungen

	c1	c2	s1	m	m1	m2(H7)	i1	u	k	d1	t1	e1
71/B5	4	9	11	130	160	110	84	12	231	14	5	16.3
71/B14	3	8.5	7	85	105	70						
80/B5	4	5	12	165	200	130	84	12	260	19	6	21.8
80/B14			7	100	120	80						
90/B5	4	5	12	165	200	130	84	12	260	24	8	27.3
90/B14			9	115	140	95						
100/B5	4	6	15	215	250	180	77	12	253	28	8	31.3
100/B14		5.5	9	130	160	110						
112/B5	4	6	15	215	250	180	77	12	253	28	8	31.3
112/B14		5.5	9	130	160	110						
132/B5	4.5	7	15	265	300	230	124	15	296	38	10	41.3

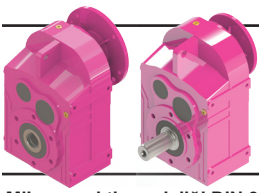

# Ölçü Sayfaları

## Dimension Pages

### Abmessungsseiten

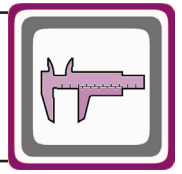

Mil ucu çektirme deliği DIN 332 sayfa 2 / Tapped center hole according to DIN 332, sheet 2 / Zentrierung mit Gewinde nach DIN 332, Blatt 2

DN375.00  
DN376.00

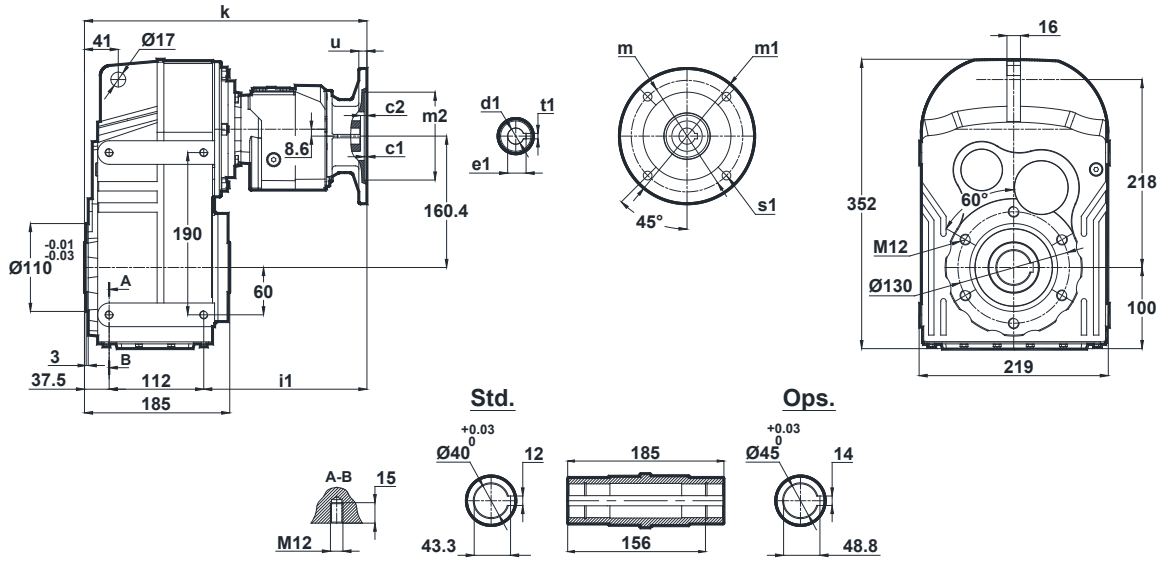

	c1	c2	s1	m	m1	m2(H7)	i1	u	k	d1	t1	e1
63/B5	4	5	10	115	140	95	199	10	349	11	4	12.8
63/B14	2.5		5.5	75	90	60						
71/B5	4	5	11	130	160	110	201	12	351	14	5	16.3
71/B14	3	4.5	7	85	105	70		10				
80/B5	4	5	12	165	200	130	216	12	366	19	6	21.8
80/B14			7	100	120	80						

DN375.01  
DN376.01

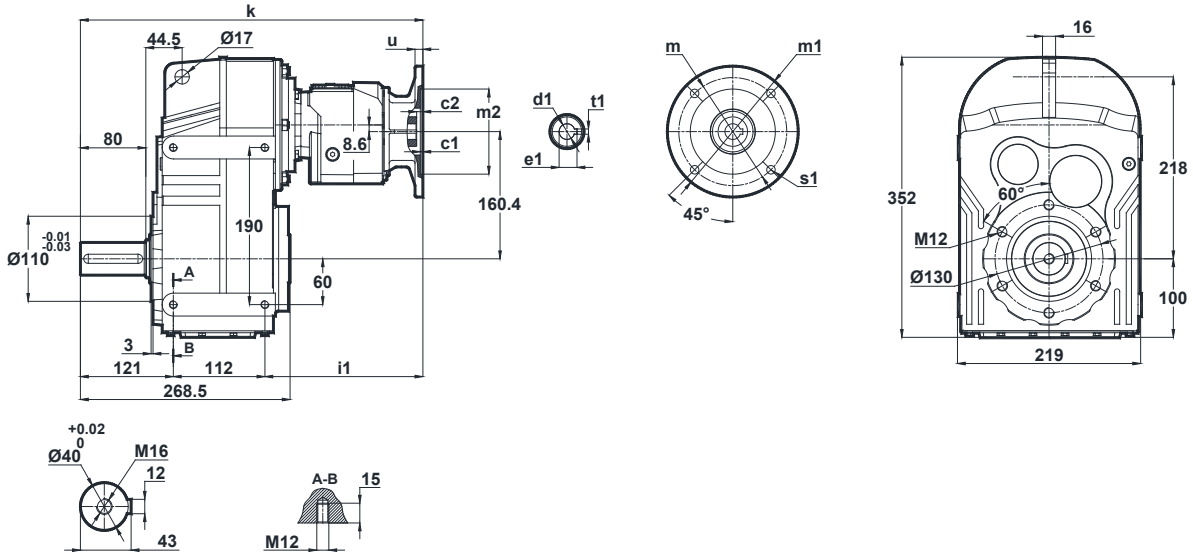

	c1	c2	s1	m	m1	m2(H7)	i1	u	k	d1	t1	e1
63/B5	4	5	10	115	140	95	199	10	432	11	4	12.8
63/B14	2.5		5.5	75	90	60						
71/B5	4	5	11	130	160	110	201	12	434	14	5	16.3
71/B14	3	4.5	7	85	105	70		10				
80/B5	4	5	12	165	200	130	216	12	449	19	6	21.8
80/B14			7	100	120	80						

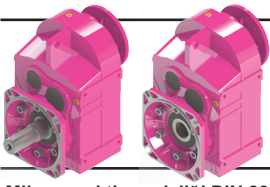

# Ölçü Sayfaları Dimension Pages Abmessungsseiten

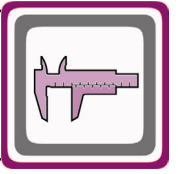

Mil ucu çektirme deliği DIN 332 sayfa 2 / Tapped center hole according to DIN 332, sheet 2 / Zentrierung mit Gewinde nach DIN 332, Blatt 2

DN375.02  
DN376.02

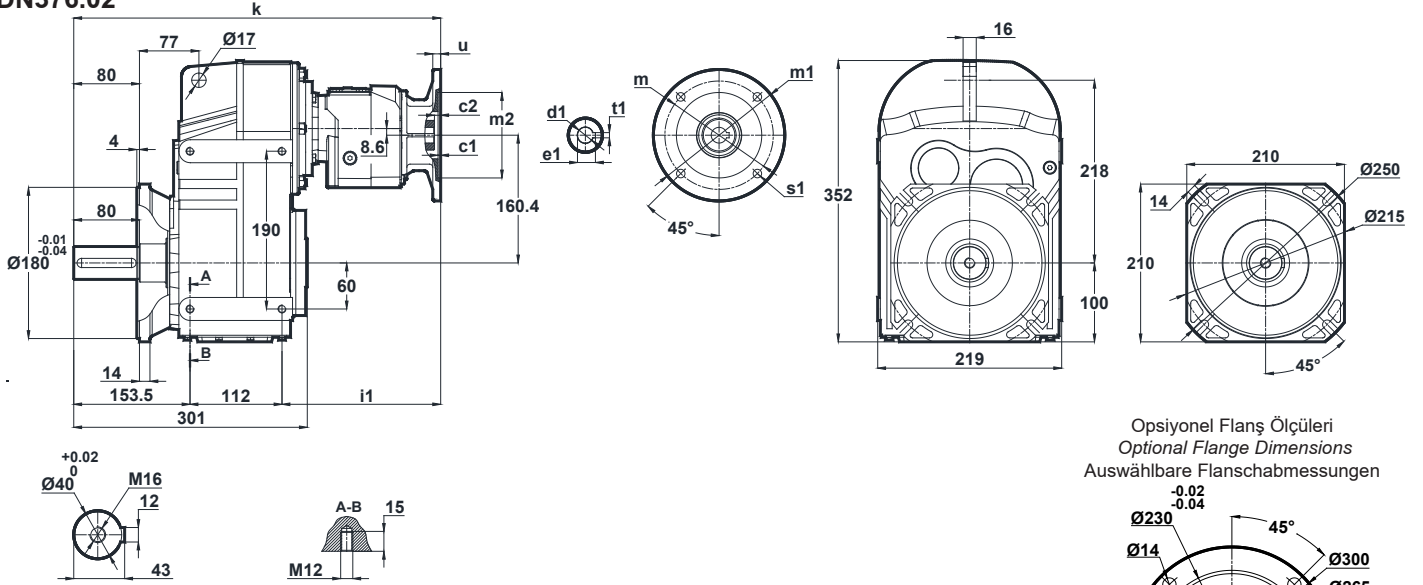

Opsiyonel Flanş Ölçüleri  
Optional Flange Dimensions  
Auswählbare Flanschabmessungen

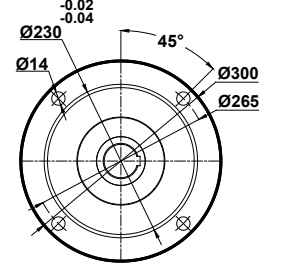

	c1	c2	s1	m	m1	m2(H7)	i1	u	k	d1	t1	e1
63/B5	4	5	10	115	140	95	199	10	465	11	4	12.8
63/B14	2.5	5	5.5	75	90	60	199	10	465	11	4	12.8
71/B5	4	5	11	130	160	110	201	12	467	14	5	16.3
71/B14	3	4.5	7	85	105	70	201	10	467	14	5	16.3
80/B5	4	5	12	165	200	130	216	12	482	19	6	21.8
80/B14	4	5	7	100	120	80	216	12	482	19	6	21.8

DN375.03  
DN376.03

Diğer opsiyonel flanş ölçüleri için sayfa 326'ya bakınız.  
Please see on page 326 for other optional flange dimensions  
Siehe Siete 326 für andere auswählbare Flanschabmessungen

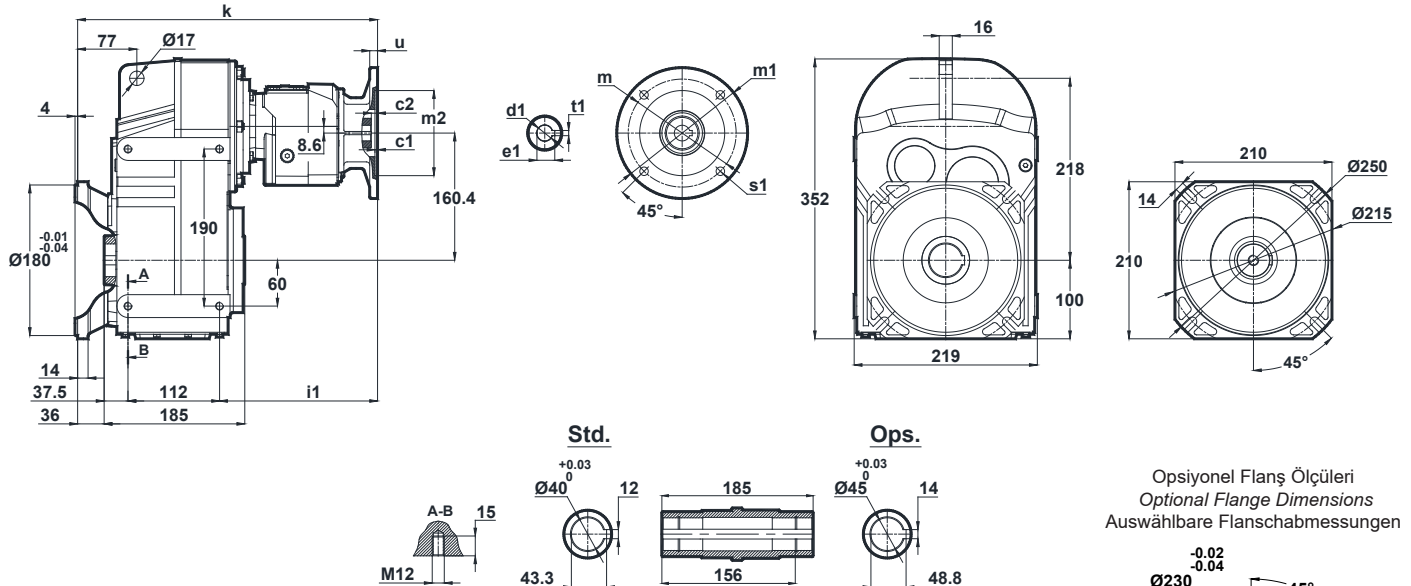

Opsiyonel Flanş Ölçüleri  
Optional Flange Dimensions  
Auswählbare Flanschabmessungen

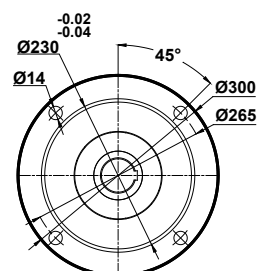

	c1	c2	s1	m	m1	m2(H7)	i1	u	k	d1	t1	e1
63/B5	4	5	10	115	140	95	199	10	385	11	4	12.8
63/B14	2.5	5	5.5	75	90	60	199	10	385	11	4	12.8
71/B5	4	5	11	130	160	110	201	12	387	14	5	16.3
71/B14	3	4.5	7	85	105	70	201	10	387	14	5	16.3
80/B5	4	5	12	165	200	130	216	12	402	19	6	21.8
80/B14	4	5	7	100	120	80	216	12	402	19	6	21.8

Diğer opsiyonel flanş ölçüleri için sayfa 326'ya bakınız.  
Please see on page 326 for other optional flange dimensions  
Siehe Siete 326 für andere auswählbare Flanschabmessungen

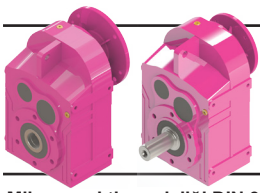

# Ölçü Sayfaları

## Dimension Pages

### Abmessungsseiten

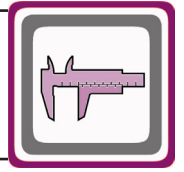

Mil ucu çekirme deliği DIN 332 sayfa 2 / Tapped center hole according to DIN 332, sheet 2 / Zentrierung mit Gewinde nach DIN 332, Blatt 2

DN472.00  
DN473.00

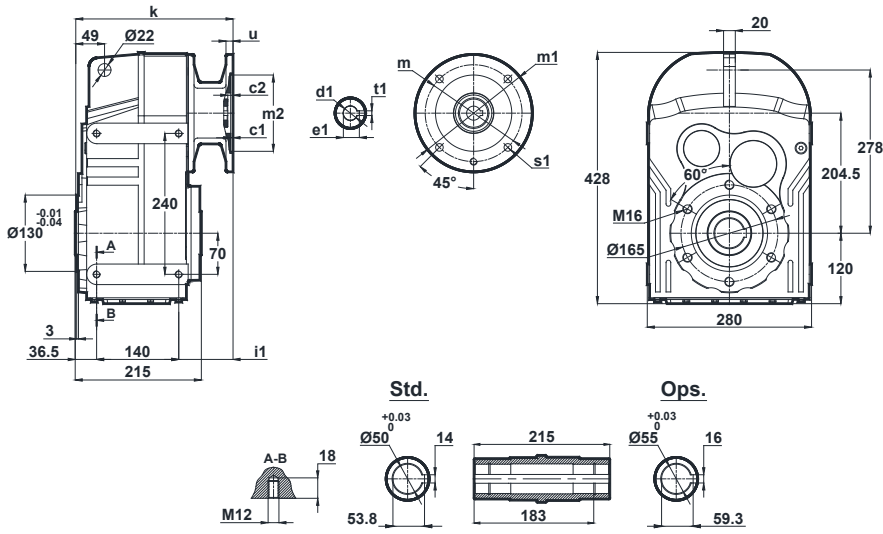

	c1	c2	s1	m	m1	m2(H7)	i1	u	k	d1	t1	e1
71/B5	4	9	11	130	160	110	83	12	260	14	5	16.3
80/B5	4	9	12	165	200	130	83	12	260	19	6	21.8
80/B14			7	100	120	80						
90/B5	4	9	12	165	200	130	83	12	260	24	8	27.3
90/B14			9	115	140	95						
100/B5	5	9	15	215	250	180	100	15	277	28	8	31.3
100/B14	4	9	9	130	160	110						
112/B5	5	9	15	215	250	180	100	15	277	28	8	31.3
112/B14	4	9	9	130	160	110						
132/B5	5	7	15	265	300	230	120	15	297	38	10	41.3
132/B14	4.5	7	11	165	200	130						
160/B5	5.5	10	19	300	350	250	199	20	376	42	12	45.3

DN472.01  
DN473.01

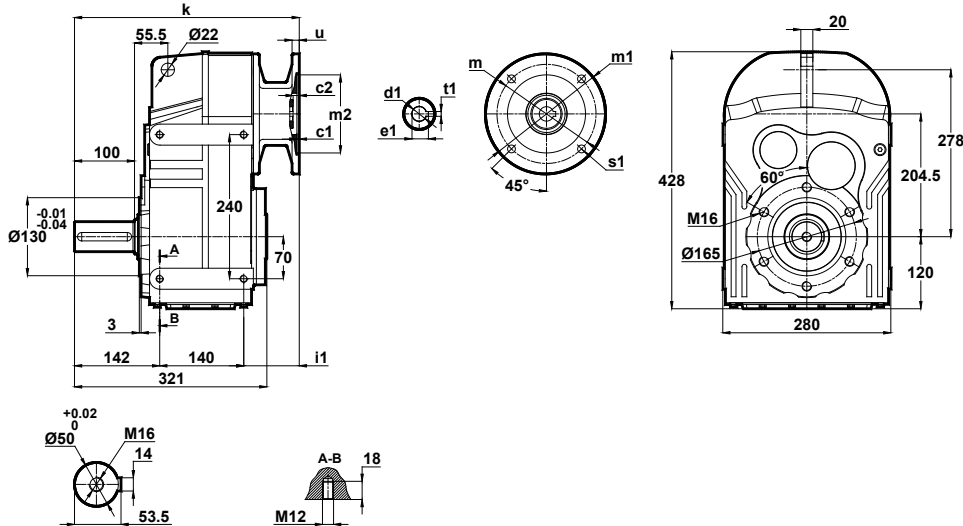

	c1	c2	s1	m	m1	m2(H7)	i1	u	k	d1	t1	e1
71/B5	4	9	11	130	160	110	83	12	365	14	5	16.3
80/B5	4	9	12	165	200	130	83	12	365	19	6	21.8
80/B14			7	100	120	80						
90/B5	4	9	12	165	200	130	83	12	365	24	8	27.3
90/B14			9	115	140	95						
100/B5	5	9	15	215	250	180	100	15	382	28	8	31.3
100/B14	4	9	9	130	160	110						
112/B5	5	9	15	215	250	180	100	15	382	28	8	31.3
112/B14	4	9	9	130	160	110						
132/B5	5	7	15	265	300	230	120	15	402	38	10	41.3
132/B14	4.5	7	11	165	200	130						
160/B5	5.5	10	19	300	350	250	199	20	481	42	12	45.3

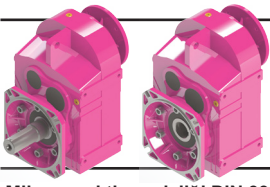

# Ölçü Sayfaları Dimension Pages Abmessungenseiten

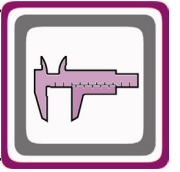

Mil ucu çektirme deliği DIN 332 sayfa 2 / Tapped center hole according to DIN 332, sheet 2 / Zentrierung mit Gewinde nach DIN 332, Blatt 2

DN472.02  
DN473.02

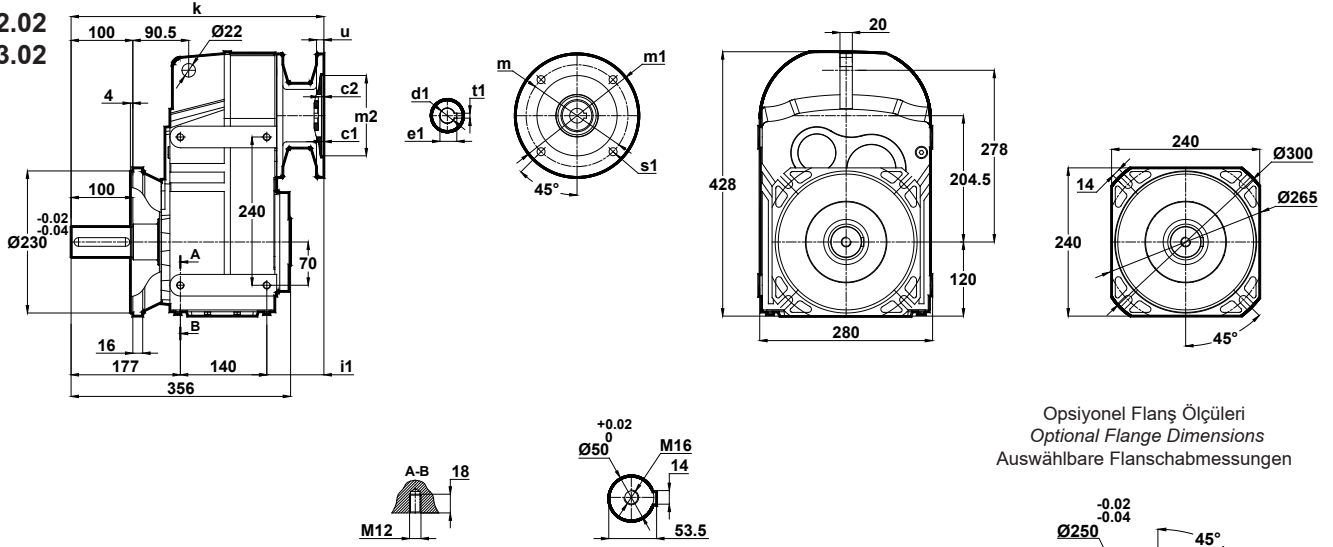

Opsiyonel Flanş Ölçüleri  
Optional Flange Dimensions  
Auswählbare Flanschabmessungen

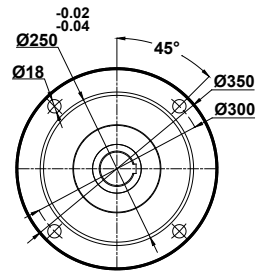

Diğer opsiyonel flanş ölçüleri için sayfa 326'ya bakınız.  
Please see on page 326 for other optional flange dimensions  
Siehe Seite 326 für andere auswählbare Flanschabmessungen

	c1	c2	s1	m	m1	m2(H7)	i1	u	k	d1	t1	e1
71/B5	4	9	11	130	160	110	83	12	400	14	5	16.3
80/B5	4	9	12	165	200	130	83	12	400	19	6	21.8
80/B14			7	100	120	80						
90/B5	4	9	12	165	200	130	83	12	400	24	8	27.3
90/B14			9	115	140	95						
100/B5	5	9	15	215	250	180	100	15	417	28	8	31.3
100/B14	4	9	9	130	160	110						
112/B5	5	9	15	215	250	180	100	15	417	28	8	31.3
112/B14	4	9	9	130	160	110						
132/B5	5	7	15	265	300	230	120	15	437	38	10	41.3
132/B14	4.5	11	11	165	200	130						
160/B5	5.5	10	19	300	350	250	199	20	516	42	12	45.3

DN472.03  
DN473.03

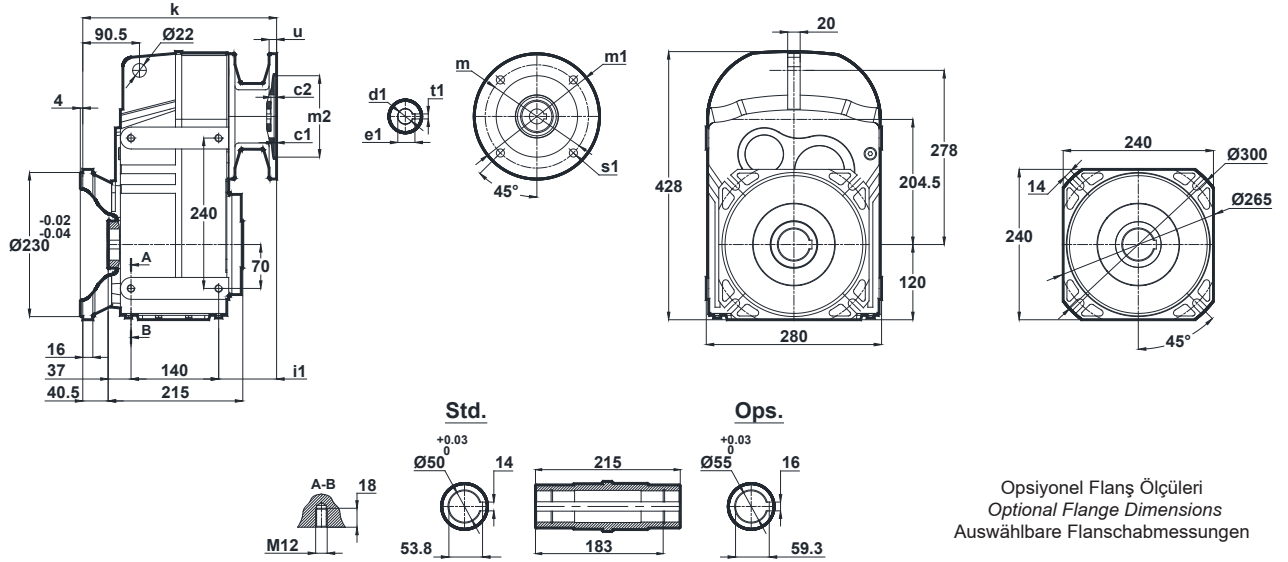

Opsiyonel Flanş Ölçüleri  
Optional Flange Dimensions  
Auswählbare Flanschabmessungen

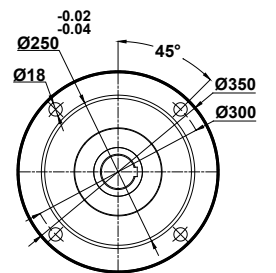

Diğer opsiyonel flanş ölçüleri için sayfa 326'ya bakınız.  
Please see on page 326 for other optional flange dimensions  
Siehe Seite 326 für andere auswählbare Flanschabmessungen

	c1	c2	s1	m	m1	m2(H7)	i1	u	k	d1	t1	e1
71/B5	4	9	11	130	160	110	83	12	300	14	5	16.3
80/B5	4	9	12	165	200	130	83	12	300	19	6	21.8
80/B14			7	100	120	80						
90/B5	4	9	12	165	200	130	83	12	300	24	8	27.3
90/B14			9	115	140	95						
100/B5	5	9	15	215	250	180	100	15	317	28	8	31.3
100/B14	4	9	9	130	160	110						
112/B5	5	9	15	215	250	180	100	15	317	28	8	31.3
112/B14	4	9	9	130	160	110						
132/B5	5	7	15	265	300	230	120	15	337	38	10	41.3
132/B14	4.5	11	11	165	200	130						
160/B5	5.5	10	19	300	350	250	199	20	416	42	12	45.3

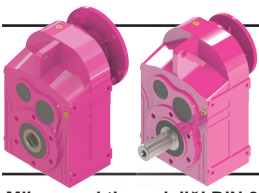

# Ölçü Sayfaları

## Dimension Pages

### Abmessungsseiten

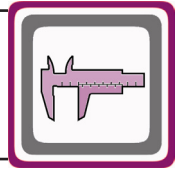

Mil ucu çektirme deliği DIN 332 sayfa 2 / Tapped center hole according to DIN 332, sheet 2 / Zentrierung mit Gewinde nach DIN 332, Blatt 2

**DN474.00**

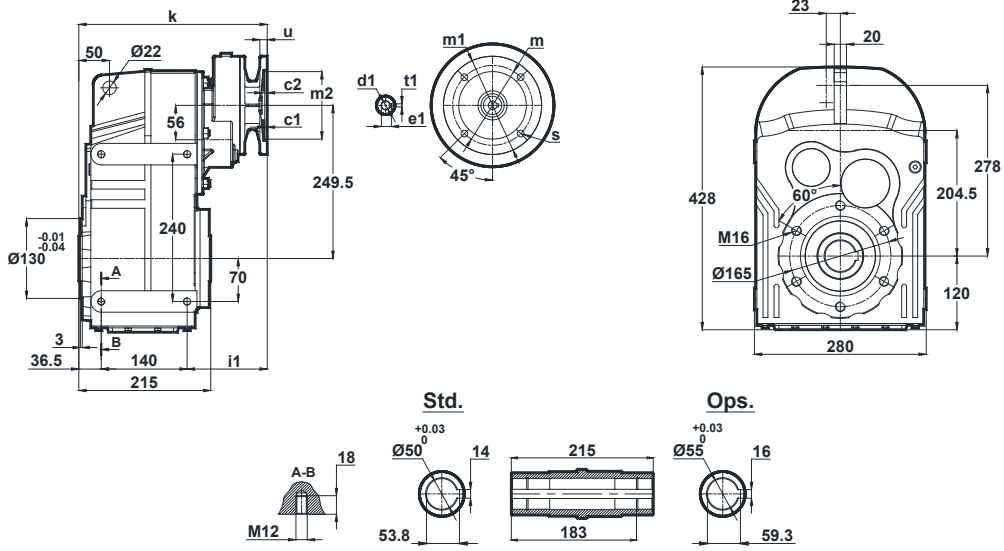

	c1	c2	s1	m	m1	m2(H7)	i1	u	k	d1	t1	e1
<b>63/B5</b>	4	8	9	115	140	95	160	12	337	11	4	12.8
<b>71/B5</b>	4	9	11	130	160	110	131	12	308	14	5	16.3
<b>71/B14</b>	3	8.5	7	85	105	70	10	10				
<b>80/B5</b>	4	5	12	165	200	130	166	12	343	19	6	21.8
<b>80/B14</b>	4	5	7	100	120	80	166	12	343	19	6	21.8

**DN474.01**

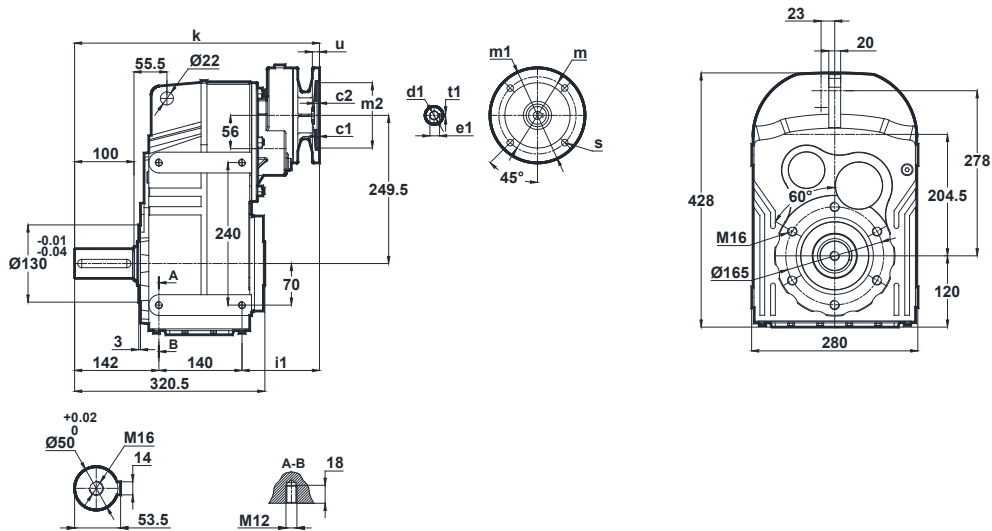

	c1	c2	s1	m	m1	m2(H7)	i1	u	k	d1	t1	e1
<b>63/B5</b>	4	8	9	115	140	95	160	12	442	11	4	12.8
<b>71/B5</b>	4	9	11	130	160	110	131	12	413	14	5	16.3
<b>71/B14</b>	3	8.5	7	85	105	70	10	10				
<b>80/B5</b>	4	5	12	165	200	130	166	12	448	19	6	21.8
<b>80/B14</b>	4	5	7	100	120	80	166	12	448	19	6	21.8

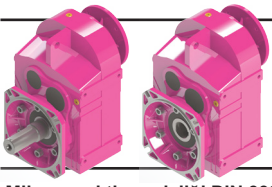

# Ölçü Sayfaları Dimension Pages Abmessungenseiten

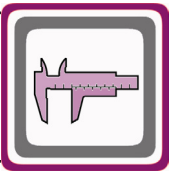

Mil ucu çektirme deliği DIN 332 sayfa 2 / Tapped center hole according to DIN 332, sheet 2 / Zentrierung mit Gewinde nach DIN 332, Blatt 2

## DN474.02

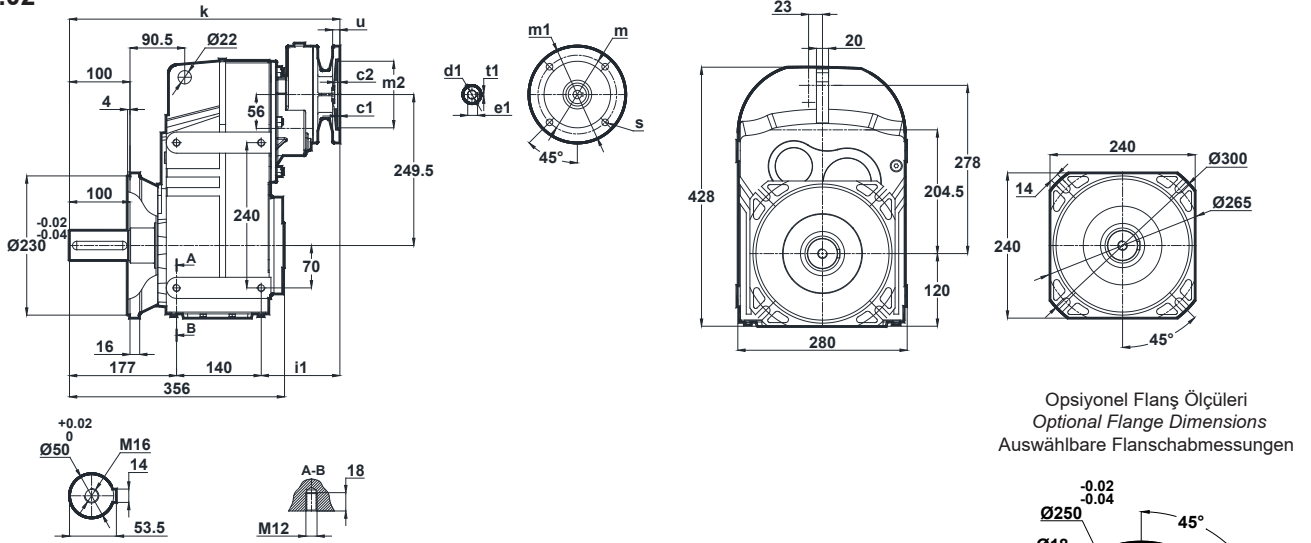

Opsiyonel Flanş Ölçüleri  
Optional Flange Dimensions  
Auswählbare Flanschabmessungen

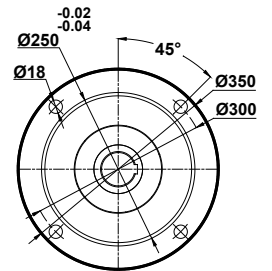

	c1	c2	s1	m	m1	m2(H7)	i1	u	k	d1	t1	e1
63/B5	4	8	9	115	140	95	160	12	477	11	4	12.8
71/B5	4	9	11	130	160	110	131	12	448	14	5	16.3
71/B14	3	8.5	7	85	105	70	70	10	448	14	5	16.3
80/B5	4	5	12	165	200	130	166	12	483	19	6	21.8
80/B14	4	5	7	100	120	80	166	12	483	19	6	21.8

Diğer opsiyonel flanş ölçüleri için sayfa 326'ya bakınız.  
Please see on page 326 for other optional flange dimensions  
Siehe Seite 326 für andere auswählbare Flanschabmessungen

## DN474.03

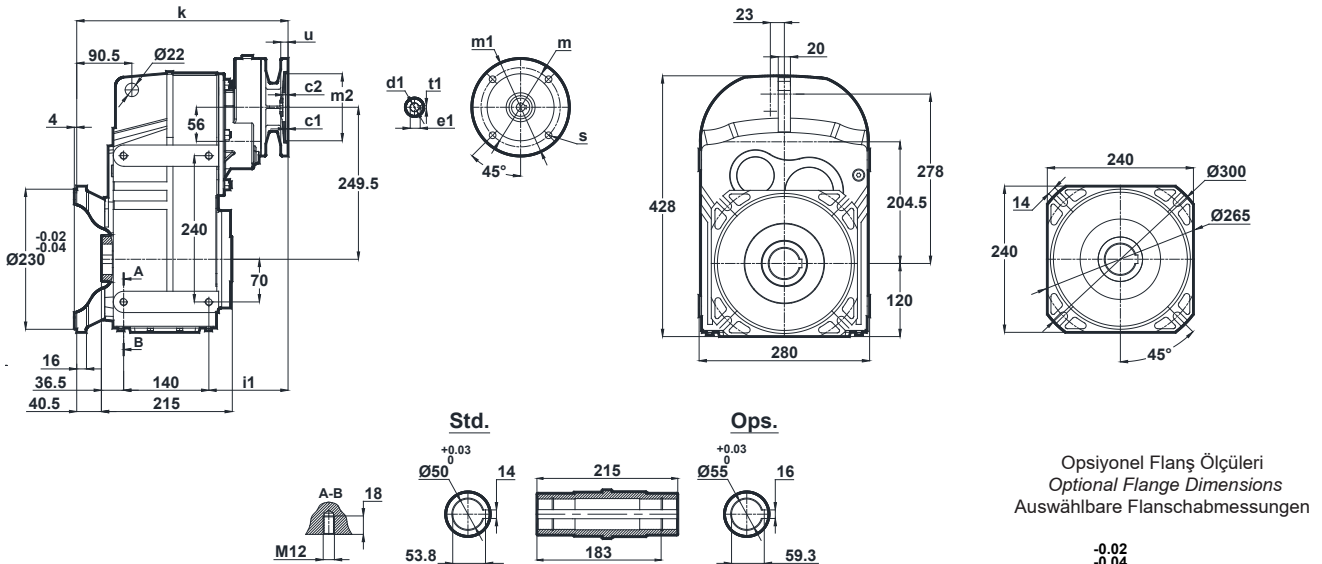

Opsiyonel Flanş Ölçüleri  
Optional Flange Dimensions  
Auswählbare Flanschabmessungen

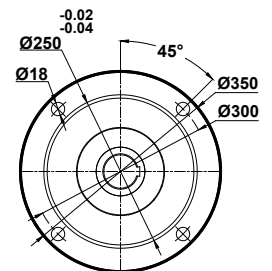

	c1	c2	s1	m	m1	m2(H7)	i1	u	k	d1	t1	e1
63/B5	4	8	9	115	140	95	160	12	377	11	4	12.8
71/B5	4	9	11	130	160	110	131	12	348	14	5	16.3
71/B14	3	8.5	7	85	105	70	70	10	348	14	5	16.3
80/B5	4	5	12	165	200	130	166	12	383	19	6	21.8
80/B14	4	5	7	100	120	80	166	12	383	19	6	21.8

Diğer opsiyonel flanş ölçüleri için sayfa 326'ya bakınız.  
Please see on page 326 for other optional flange dimensions  
Siehe Seite 326 für andere auswählbare Flanschabmessungen

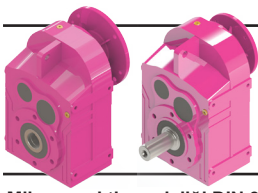

# Ölçü Sayfaları

## Dimension Pages

### Abmessungsseiten

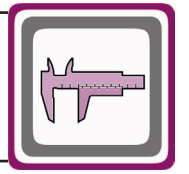

Mil ucu çekirtme deliği DIN 332 sayfa 2 / Tapped center hole according to DIN 332, sheet 2 / Zentrierung mit Gewinde nach DIN 332, Blatt 2

DN475.00  
DN476.00

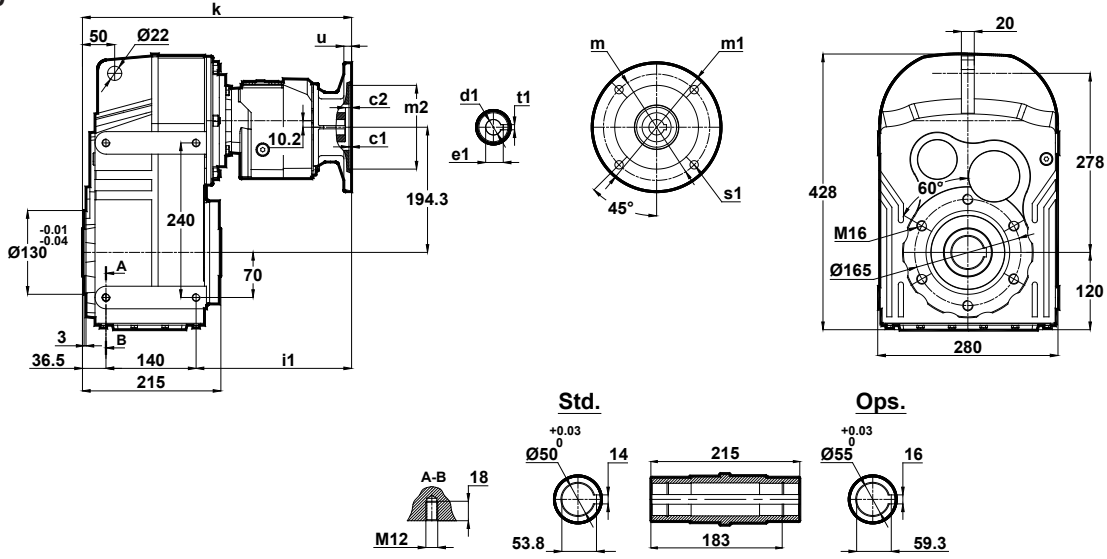

	c1	c2	s1	m	m1	m2(H7)	i1	u	k	d1	t1	e1
63/B5	4	5	10	115	140	95	226	10	402	11	4	12.8
63/B14	2.5	5	5.5	75	90	60	226	10	402	11	4	12.8
71/B5	4	5	11	130	160	110	241	12	404	14	5	16.3
71/B14	3	4.5	7	85	105	70	241	10	404	14	5	16.3

DN475.01  
DN476.01

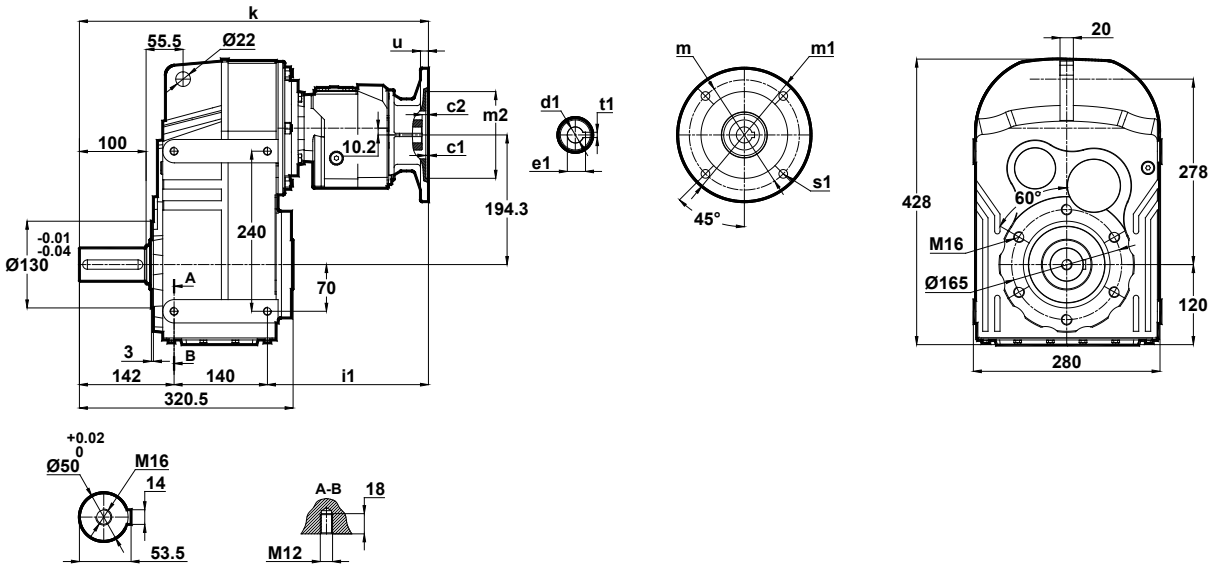

	c1	c2	s1	m	m1	m2(H7)	i1	u	k	d1	t1	e1
63/B5	4	5	10	115	140	95	226	10	507	11	4	12.8
63/B14	2.5	5	5.5	75	90	60	226	10	507	11	4	12.8
71/B5	4	5	11	130	160	110	241	12	509	14	5	16.3
71/B14	3	4.5	7	85	105	70	241	10	509	14	5	16.3

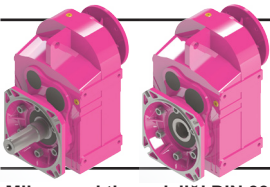

# Ölçü Sayfaları Dimension Pages Abmessungsseiten

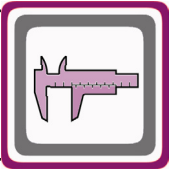

Mil ucu çektirme deliği DIN 332 sayfa 2 / Tapped center hole according to DIN 332, sheet 2 / Zentrierung mit Gewinde nach DIN 332, Blatt 2

DN475.02  
DN476.02

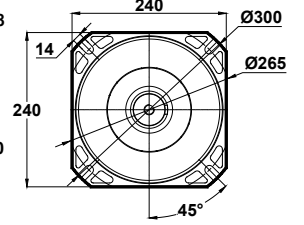
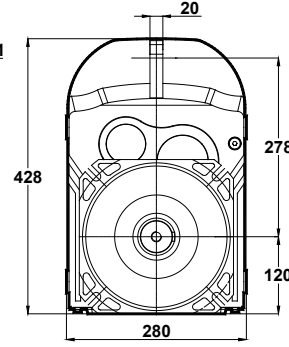
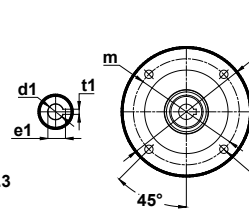
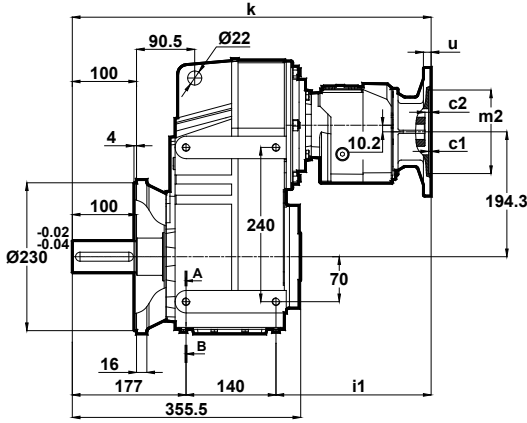

Opsiyonel Flanş Ölçüleri  
Optional Flange Dimensions  
Auswählbare Flanschabmessungen

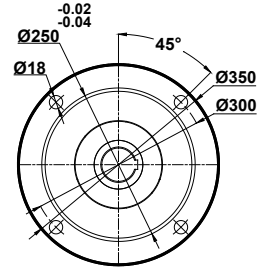
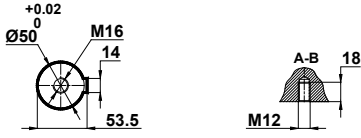

	c1	c2	s1	m	m1	m2(H7)	i1	u	k	d1	t1	e1
63/B5	4		10	115	140	95	226	10	542	11	4	12.8
63/B14	2.5	5	5.5	75	90	60	226	10	542	11	4	12.8
71/B5	4	5	11	130	160	110	241	12	544	14	5	16.3
71/B14	3	4.5	7	85	105	70	241	10	544	14	5	16.3

Diğer opsiyonel flanş ölçüleri için sayfa 326'ya bakınız.  
Please see on page 326 for other optional flange dimensions  
Siehe Seite 326 für andere auswählbare Flanschabmessungen

DN475.03  
DN476.03

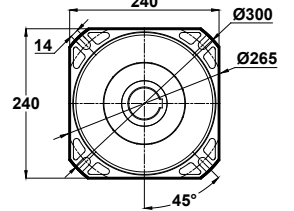
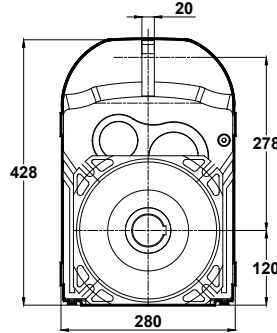
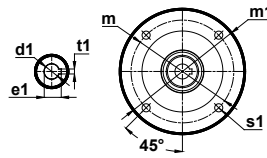
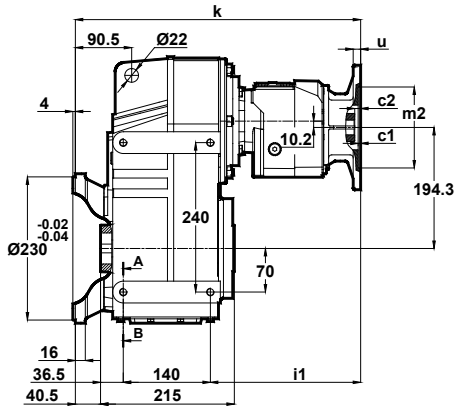

Opsiyonel Flanş Ölçüleri  
Optional Flange Dimensions  
Auswählbare Flanschabmessungen

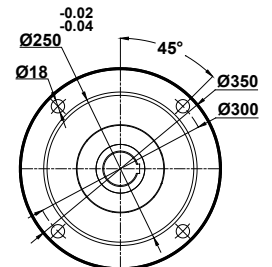
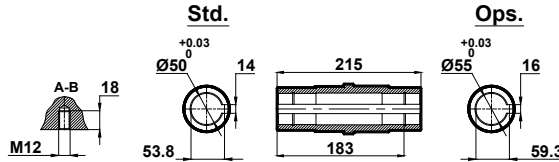

	c1	c2	s1	m	m1	m2(H7)	i1	u	k	d1	t1	e1
63/B5	4	5	10	115	140	95	226	10	442	11	4	12.8
63/B14	2.5	5	5.5	75	90	60	226	10	442	11	4	12.8
71/B5	4	5	11	130	160	110	241	12	444	14	5	16.3
71/B14	3	4.5	7	85	105	70	241	10	444	14	5	16.3

Diğer opsiyonel flanş ölçüleri için sayfa 326'ya bakınız.  
Please see on page 326 for other optional flange dimensions  
Siehe Seite 326 für andere auswählbare Flanschabmessungen

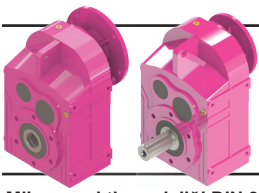

# Ölçü Sayfaları Dimension Pages Abmessungenseiten

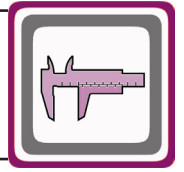

Mil ucu çektirme deliği DIN 332 sayfa 2 / Tapped center hole according to DIN 332, sheet 2 / Zentrierung mit Gewinde nach DIN 332, Blatt 2

DN572.00  
DN573.00

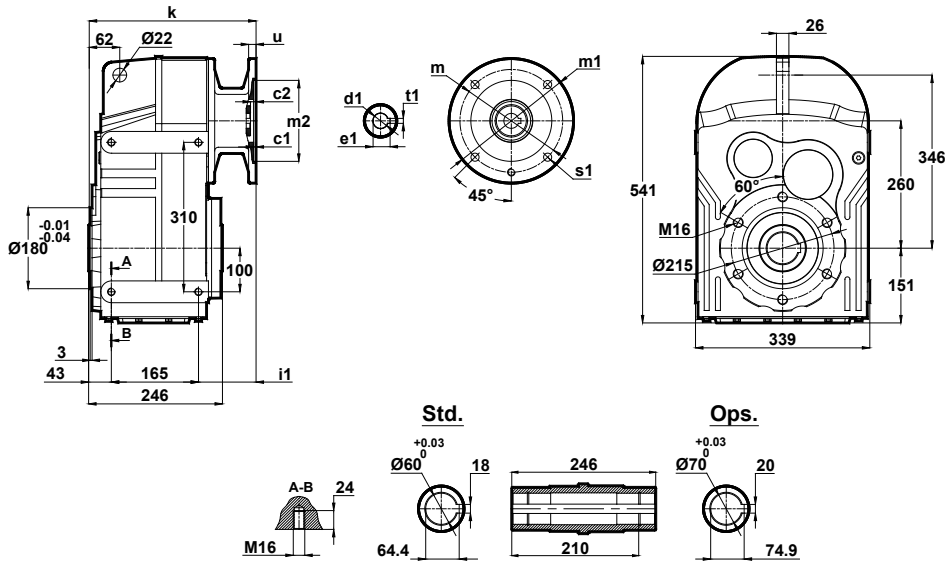

	c1	c2	s1	m	m1	m2(H7)	i1	u	k	d1	t1	e1
80/B5	4	5	12	165	200	130	68	12	277	19	6	21.8
90/B5	4	5	12	165	200	130	68	12	277	24	8	27.3
90/B14	4	5	9	115	140	95	68	12	277	24	8	27.3
100/B5	5	9	15	215	250	180	87	15	295	28	8	31.3
100/B14	4	9	9	130	160	110	87	15	295	28	8	31.3
112/B5	5	9	15	215	250	180	87	15	295	28	8	31.3
112/B14	4	9	9	130	160	110	87	15	295	28	8	31.3
132/B5	5	6	15	265	300	230	105	15	314	38	10	41.3
132/B14	4.5	6	11	165	200	130	105	15	314	38	10	41.3
160/B5	5.5	10	19	300	350	250	185	20	393	42	12	45.3
180/B5	6	10	19	300	350	250	185	20	393	48	14	51.8

DN572.01  
DN573.01

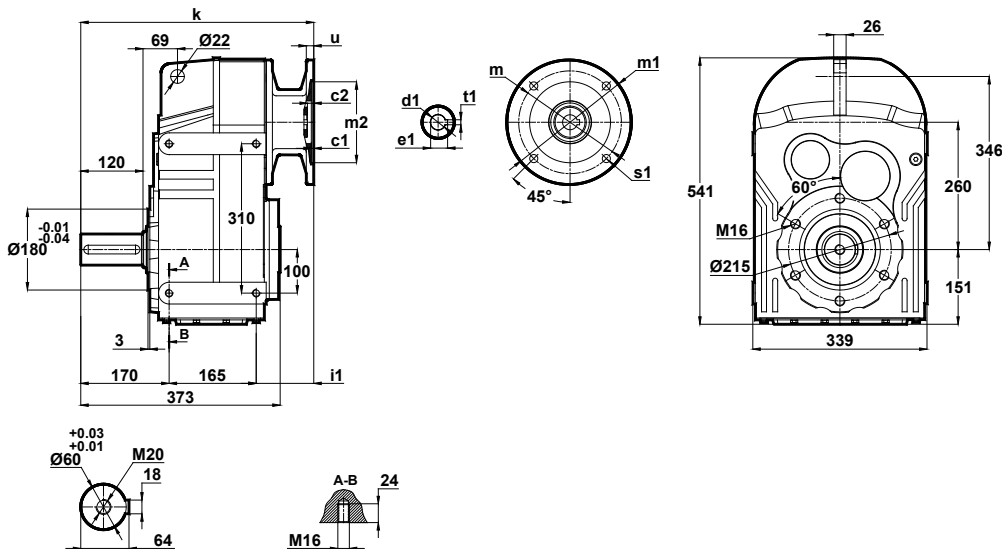

	c1	c2	s1	m	m1	m2(H7)	i1	u	k	d1	t1	e1
80/B5	4	5	12	165	200	130	68	12	404	19	6	21.8
90/B5	4	5	12	165	200	130	68	12	404	24	8	27.3
90/B14	4	5	9	115	140	95	68	12	404	24	8	27.3
100/B5	5	9	15	215	250	180	87	15	422	28	8	31.3
100/B14	4	9	9	130	160	110	87	15	422	28	8	31.3
112/B5	5	9	15	215	250	180	87	15	422	28	8	31.3
112/B14	4	9	9	130	160	110	87	15	422	28	8	31.3
132/B5	5	6	15	265	300	230	105	15	441	38	10	41.3
132/B14	4.5	6	11	165	200	130	105	15	441	38	10	41.3
160/B5	5.5	10	19	300	350	250	185	20	520	42	12	45.3
180/B5	6	10	19	300	350	250	185	20	520	48	14	51.8

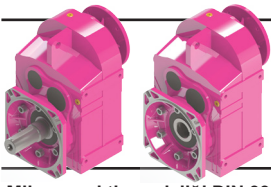

# Ölçü Sayfaları Dimension Pages Abmessungsseiten

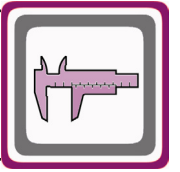

Mil ucu çektirme deliği DIN 332 sayfa 2 / Tapped center hole according to DIN 332, sheet 2 / Zentrierung mit Gewinde nach DIN 332, Blatt 2

DN572.02  
DN573.02

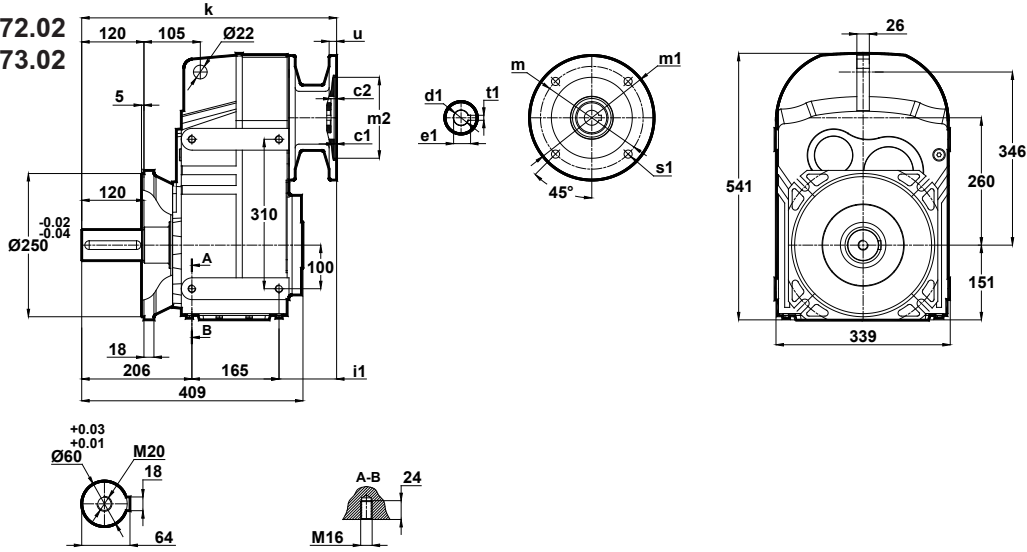

Opsiyonel Flanş Ölçüleri  
Optional Flange Dimensions  
Auswählbare Flanschabmessungen

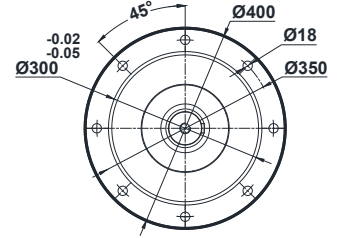

Diğer opsiyonel flanş ölçüleri için sayfa 326'ya bakınız.  
Please see on page 326 for other optional flange dimensions  
Siehe Seite 326 für andere auswählbare Flanschabmessungen

	c1	c2	s1	m	m1	m2(H7)	i1	u	k	d1	t1	e1
80/B5	4	5	12	165	200	130	68	12	440	19	6	21.8
90/B5	4	5	12	165	200	130	68	12	440	24	8	27.3
90/B14	4	5	9	115	140	95	68	12	440	24	8	27.3
100/B5	5	9	15	215	250	180	87	15	458	28	8	31.3
100/B14	4	9	9	130	160	110	87	15	458	28	8	31.3
112/B5	5	9	15	215	250	180	87	15	458	28	8	31.3
112/B14	4	9	9	130	160	110	87	15	458	28	8	31.3
132/B5	5	6	15	265	300	230	105	15	477	38	10	41.3
132/B14	4.5	6	11	165	200	130	105	15	477	38	10	41.3
160/B5	5.5	10	19	300	350	250	185	20	556	42	12	45.3
180/B5	6	10	19	300	350	250	185	20	556	48	14	51.8

DN572.03  
DN573.03

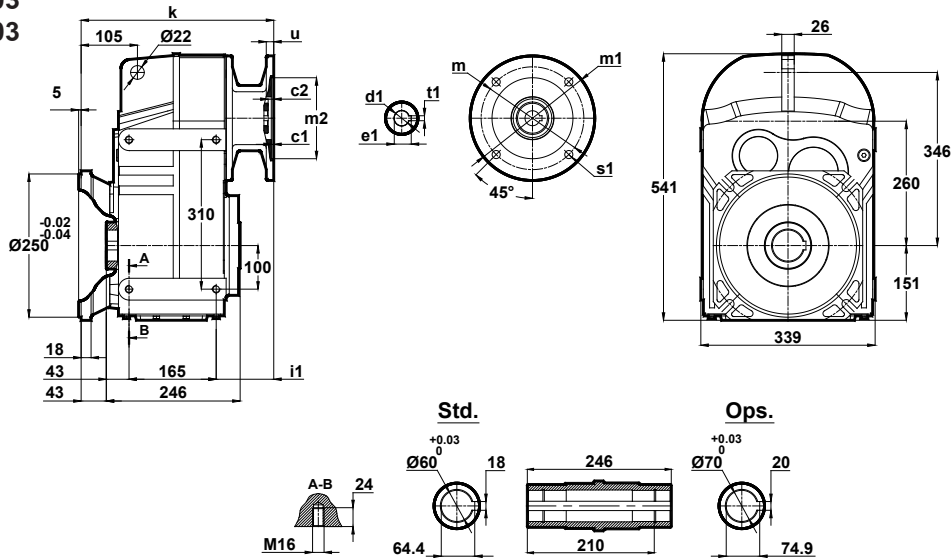

Opsiyonel Flanş Ölçüleri  
Optional Flange Dimensions  
Auswählbare Flanschabmessungen

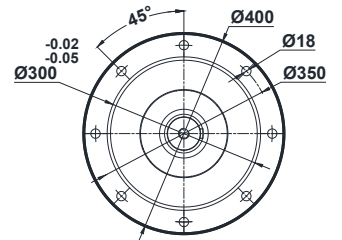

Diğer opsiyonel flanş ölçüleri için sayfa 326'ya bakınız.  
Please see on page 326 for other optional flange dimensions  
Siehe Seite 326 für andere auswählbare Flanschabmessungen

	c1	c2	s1	m	m1	m2(H7)	i1	u	k	d1	t1	e1
80/B5	4	5	12	165	200	130	68	12	320	19	6	21.8
90/B5	4	5	12	165	200	130	68	12	320	24	8	27.3
90/B14	4	5	9	115	140	95	68	12	320	24	8	27.3
100/B5	5	9	15	215	250	180	87	15	338	28	8	31.3
100/B14	4	9	9	130	160	110	87	15	338	28	8	31.3
112/B5	5	9	15	215	250	180	87	15	338	28	8	31.3
112/B14	4	9	9	130	160	110	87	15	338	28	8	31.3
132/B5	5	6	15	265	300	230	105	15	357	38	10	41.3
132/B14	4.5	6	11	165	200	130	105	15	357	38	10	41.3
160/B5	5.5	10	19	300	350	250	185	20	436	42	12	45.3
180/B5	6	10	19	300	350	250	185	20	436	48	14	51.8

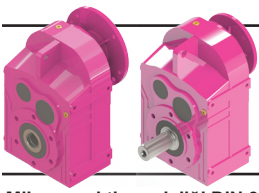

# Ölçü Sayfaları

## Dimension Pages

### Abmessungsseiten

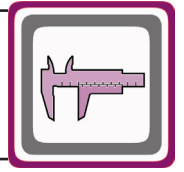

Mil ucu çekirme deliği DIN 332 sayfa 2 / Tapped center hole according to DIN 332, sheet 2 / Zentrierung mit Gewinde nach DIN 332, Blatt 2

DN574.00

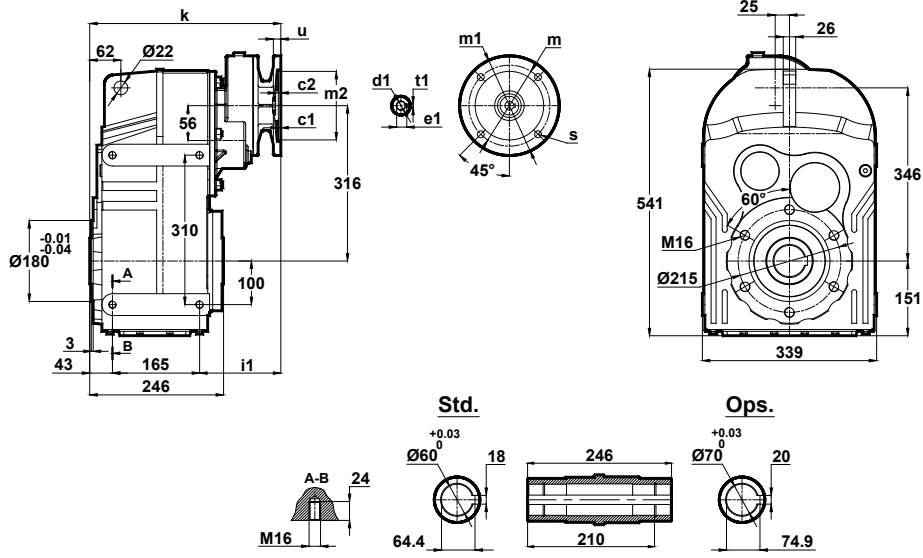

	c1	c2	s1	m	m1	m2(H7)	i1	u	k	d1	t1	e1
71/B5	4	9	11	130	160	110	166	12	375	14	5	16.3
80/B5	4	9	12	165	200	130	166	12	375	19	6	21.8
80/B14			7	100	120	80						
90/B5	4	9	12	165	200	130	166	12	375	24	8	27.3
90/B14			9	115	140	95						

DN574.01

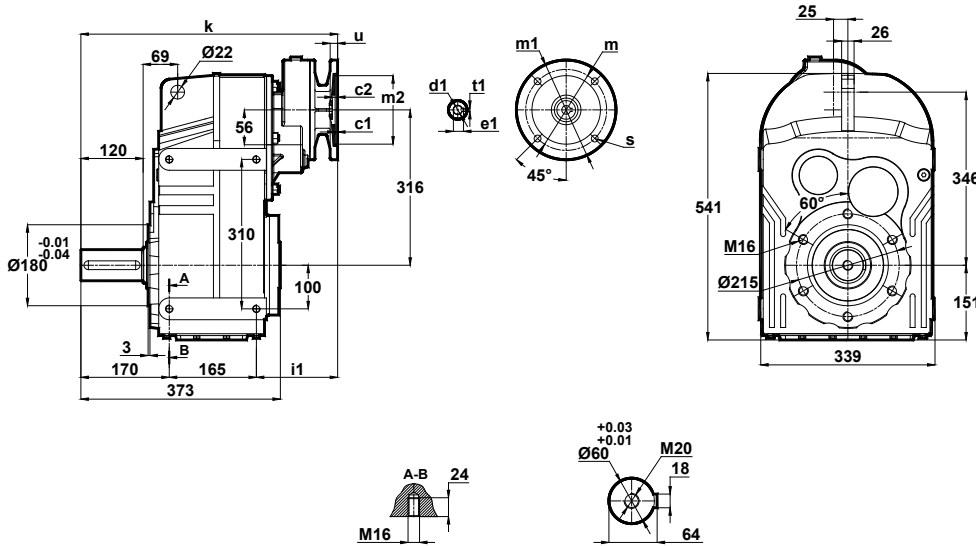

	c1	c2	s1	m	m1	m2(H7)	i1	u	k	d1	t1	e1
71/B5	4	9	11	130	160	110	166	12	502	14	5	16.3
80/B5	4	9	12	165	200	130	166	12	502	19	6	21.8
80/B14			7	100	120	80						
90/B5	4	9	12	165	200	130	166	12	502	24	8	27.3
90/B14			9	115	140	95						

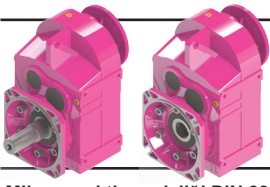

# Ölçü Sayfaları Dimension Pages Abmessungsseiten

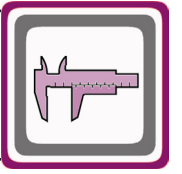

Mil ucu çektirme deliği DIN 332 sayfa 2 / Tapped center hole according to DIN 332, sheet 2 / Zentrierung mit Gewinde nach DIN 332, Blatt 2

## DN574.02

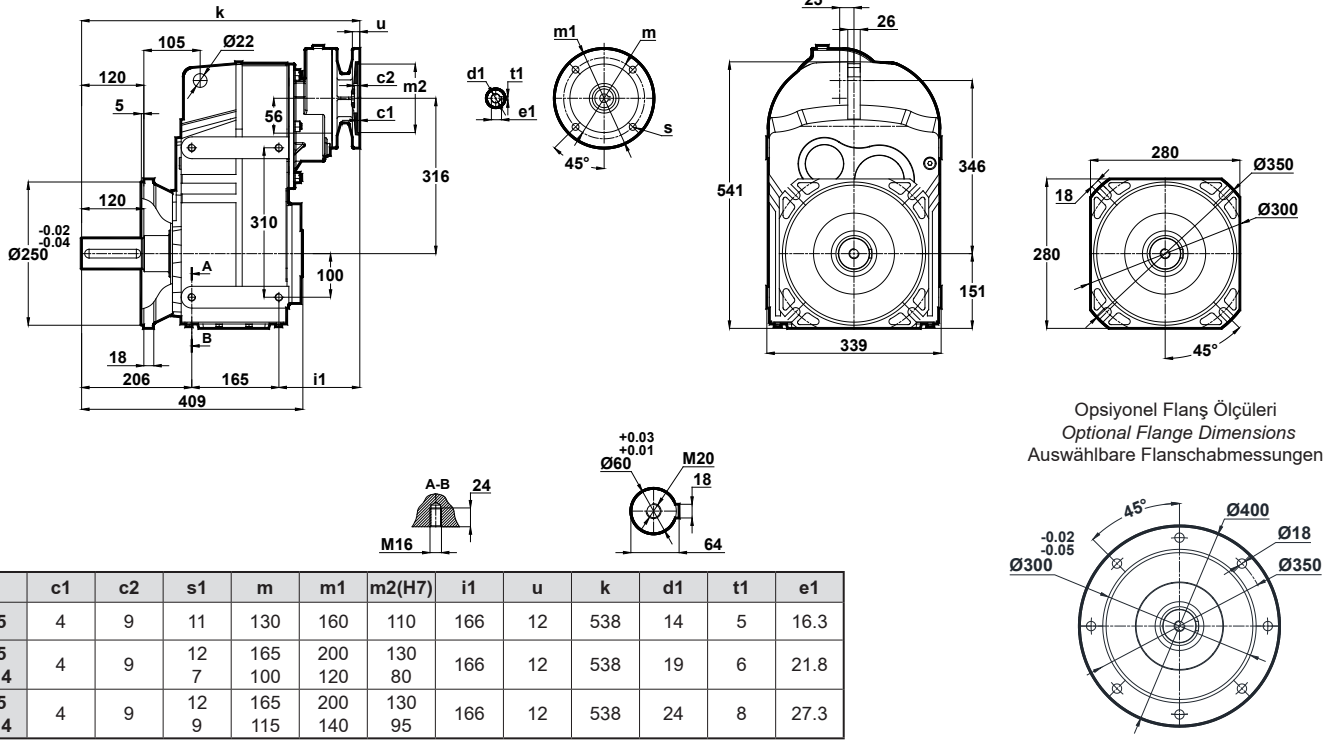

Opsiyonel Flanş Ölçüleri  
Optional Flange Dimensions  
Auswählbare Flanschabmessungen

Diğer opsiyonel flanş ölçüleri için sayfa 326'ya bakınız.  
Please see on page 326 for other optional flange dimensions  
Siehe Seite 326 für andere auswählbare Flanschabmessungen

## DN574.03

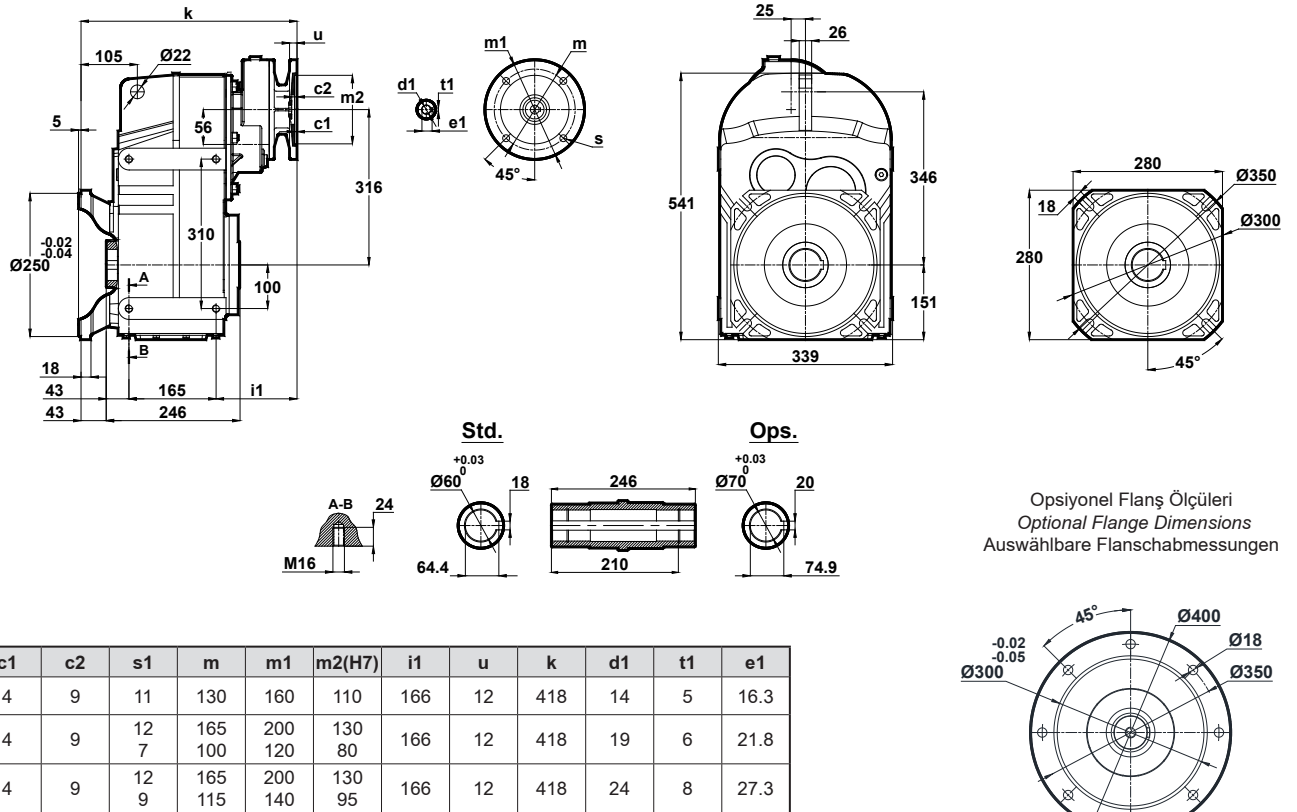

Opsiyonel Flanş Ölçüleri  
Optional Flange Dimensions  
Auswählbare Flanschabmessungen

Diğer opsiyonel flanş ölçüleri için sayfa 326'ya bakınız.  
Please see on page 326 for other optional flange dimensions  
Siehe Seite 326 für andere auswählbare Flanschabmessungen

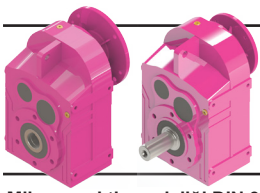

# Ölçü Sayfaları

## Dimension Pages

### Abmessungsseiten

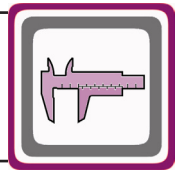

Mil ucu çekirtme deliği DIN 332 sayfa 2 / Tapped center hole according to DIN 332, sheet 2 / Zentrierung mit Gewinde nach DIN 332, Blatt 2

DN575.00  
DN576.00

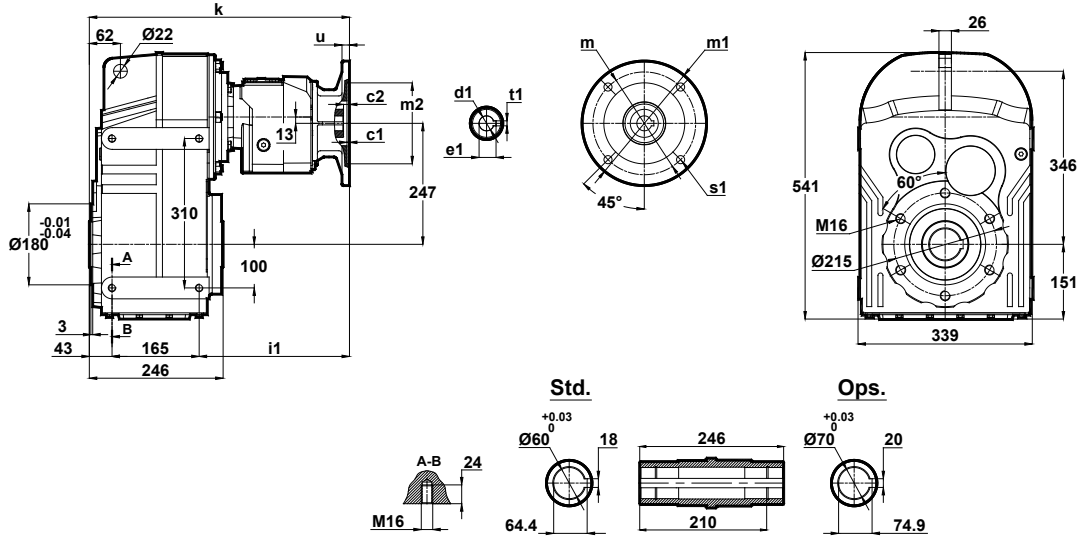

	c1	c2	s1	m	m1	m2(H7)	i1	u	k	d1	t1	e1
63/B5	4	8	9	115	140	95	294	12	503	11	4	12.8
71/B5	4	9	11	130	160	110	265	12	474	14	5	16.3
71/B14	3	8.5	7	85	105	70		10				

DN575.01  
DN576.01

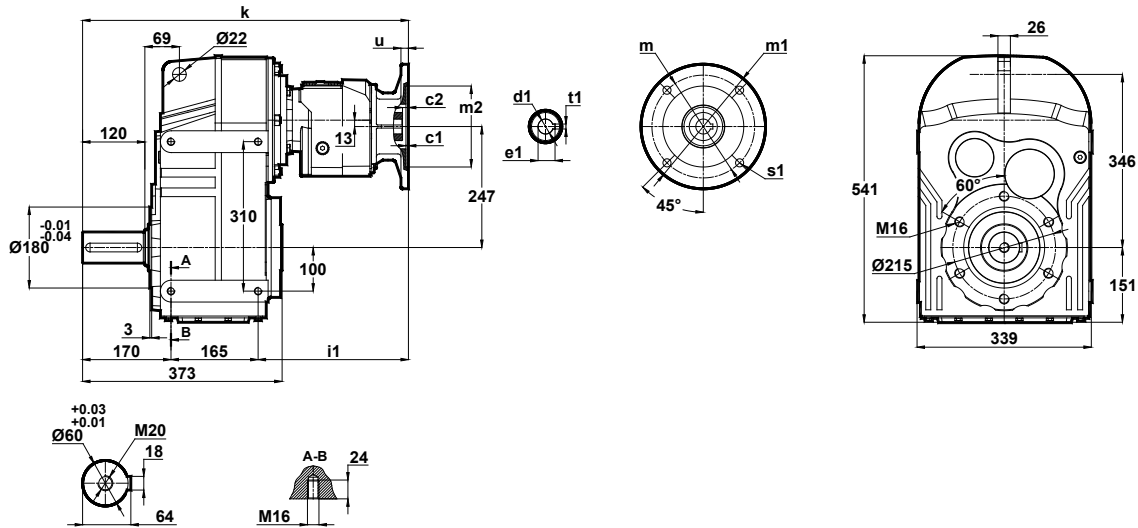

	c1	c2	s1	m	m1	m2(H7)	i1	u	k	d1	t1	e1
63/B5	4	8	9	115	140	95	294	12	630	11	4	12.8
71/B5	4	9	11	130	160	110	265	12	601	14	5	16.3
71/B14	3	8.5	7	85	105	70		10				

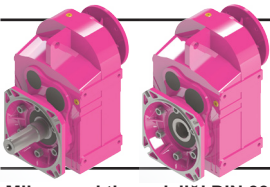

# Ölçü Sayfaları Dimension Pages Abmessungenseiten

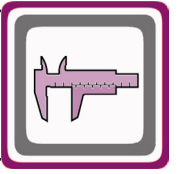

Mil ucu çektirme deliği DIN 332 sayfa 2 / Tapped center hole according to DIN 332, sheet 2 / Zentrierung mit Gewinde nach DIN 332, Blatt 2

DN575.02  
DN576.02

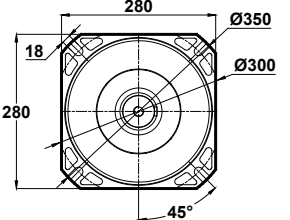
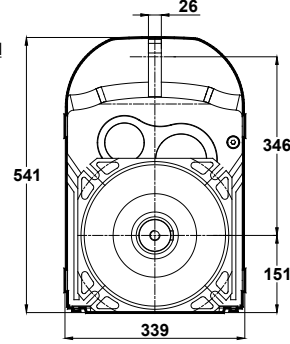
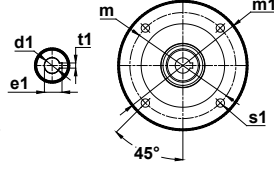
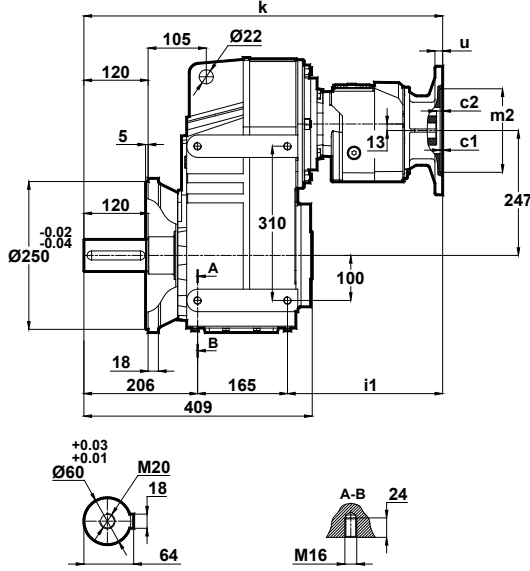

Opsiyonel Flanş Ölçüleri  
Optional Flange Dimensions  
Auswählbare Flanschabmessungen

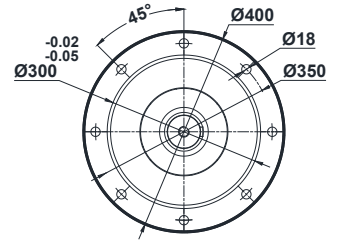

	c1	c2	s1	m	m1	m2(H7)	i1	u	k	d1	t1	e1
63/B5	4	8	9	115	140	95	294	12	666	11	4	12.8
71/B5	4	9	11	130	160	110	265	12	637	14	5	16.3
71/B14	3	8.5	7	85	105	70	265	10	637	14	5	16.3

Diğer opsiyonel flanş ölçüleri için sayfa 326'ya bakınız.  
Please see on page 326 for other optional flange dimensions  
Siehe Seite 326 für andere auswählbare Flanschabmessungen

DN575.03  
DN576.03

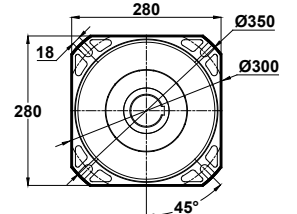
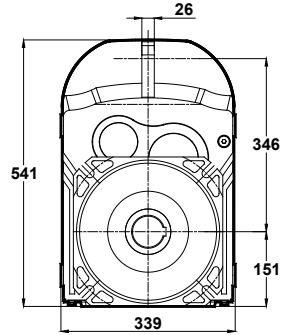
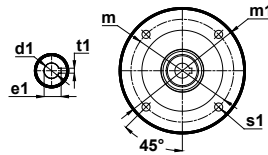
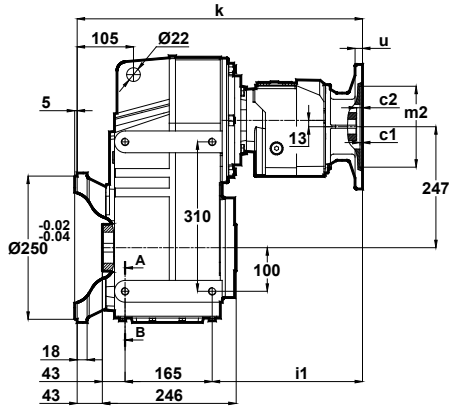

Opsiyonel Flanş Ölçüleri  
Optional Flange Dimensions  
Auswählbare Flanschabmessungen

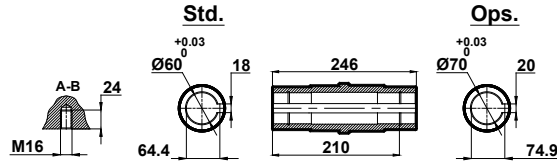

	c1	c2	s1	m	m1	m2(H7)	i1	u	k	d1	t1	e1
63/B5	4	8	9	115	140	95	294	12	546	11	4	12.8
71/B5	4	9	11	130	160	110	265	12	517	14	5	16.3
71/B14	3	8.5	7	85	105	70	265	10	517	14	5	16.3

Diğer opsiyonel flanş ölçüleri için sayfa 326'ya bakınız.  
Please see on page 326 for other optional flange dimensions  
Siehe Seite 326 für andere auswählbare Flanschabmessungen

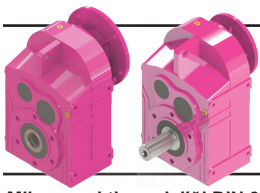

# Ölçü Sayfaları Dimension Pages Abmessungsseiten

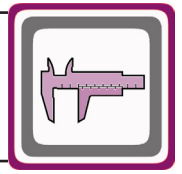

Mil ucu çektirme deliği DIN 332 sayfa 2 / Tapped center hole according to DIN 332, sheet 2 / Zentrierung mit Gewinde nach DIN 332, Blatt 2

DN672.00  
DN673.00

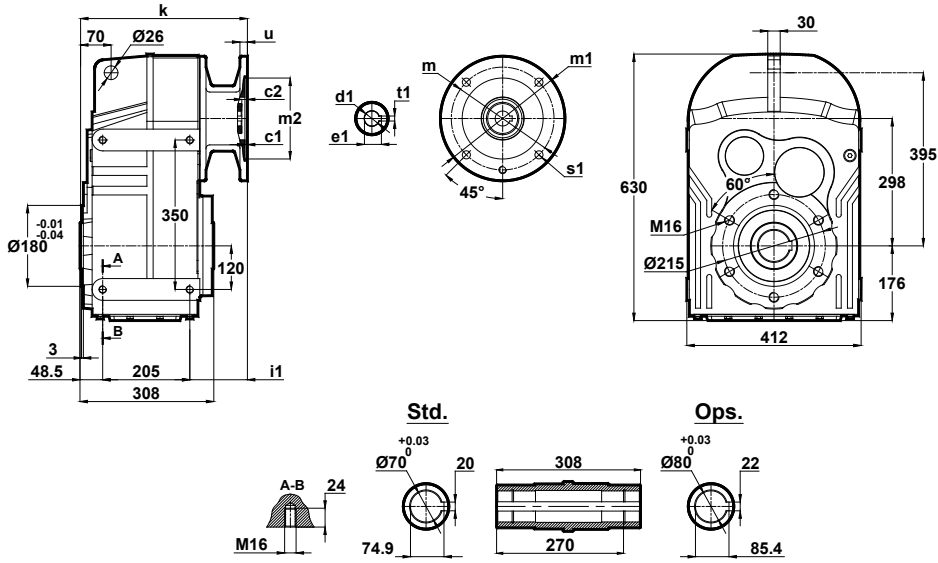

	c1	c2	s1	m	m1	m2(H7)	i1	u	k	d1	t1	e1
100/B5	5	20	15	215	250	180	94	15	348	28	8	31.3
112/B5	5	20	15	215	250	180	94	15	348	28	8	31.3
132/B5	5	9	15	265	300	230	115	15	369	38	10	41.3
132/B14	4.5		11	165	200	130						
160/B5	5.5	10	19	300	350	250	191	18	444	42	12	45.3
180/B5	6	10	19	300	350	250	191	18	444	48	14	51.8
200/B5	6	10	19	350	400	300	211	22	464	55	16	59.3

DN672.01  
DN673.01

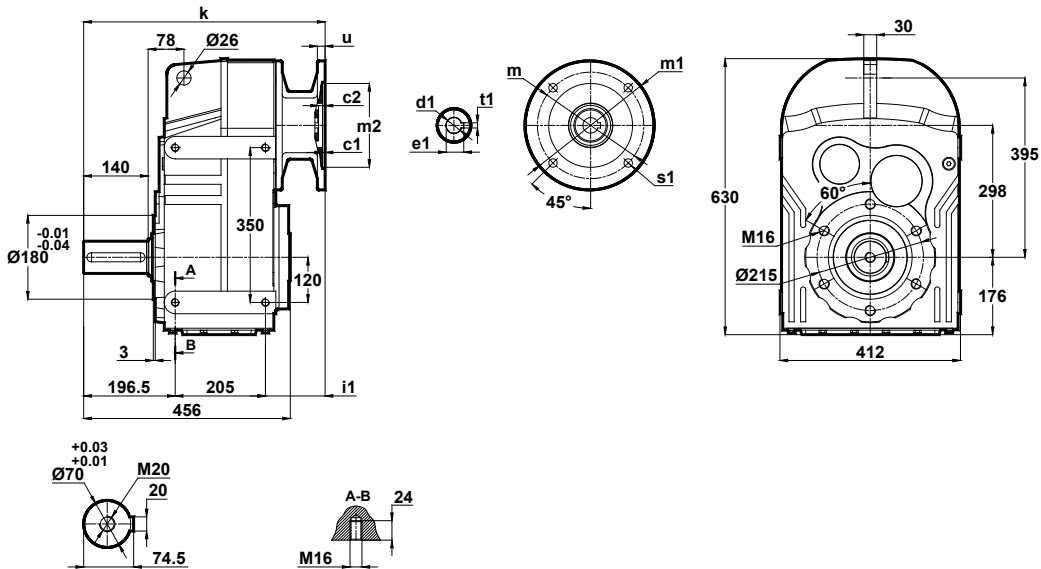

	c1	c2	s1	m	m1	m2(H7)	i1	u	k	d1	t1	e1
100/B5	5	20	15	215	250	180	94	15	496	28	8	31.3
112/B5	5	20	15	215	250	180	94	15	496	28	8	31.3
132/B5	5	9	15	265	300	230	115	15	517	38	10	41.3
132/B14	4.5		11	165	200	130						
160/B5	5.5	10	19	300	350	250	191	18	592	42	12	45.3
180/B5	6	10	19	300	350	250	191	18	592	48	14	51.8
200/B5	6	10	19	350	400	300	211	22	612	55	16	59.3

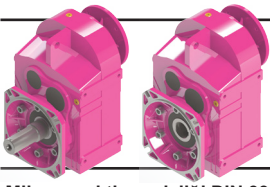

# Ölçü Sayfaları Dimension Pages Abmessungenseiten

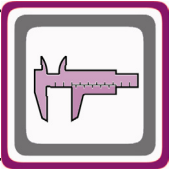

Mil ucu çektirme deliği DIN 332 sayfa 2 / Tapped center hole according to DIN 332, sheet 2 / Zentrierung mit Gewinde nach DIN 332, Blatt 2

DN672.02  
DN673.02

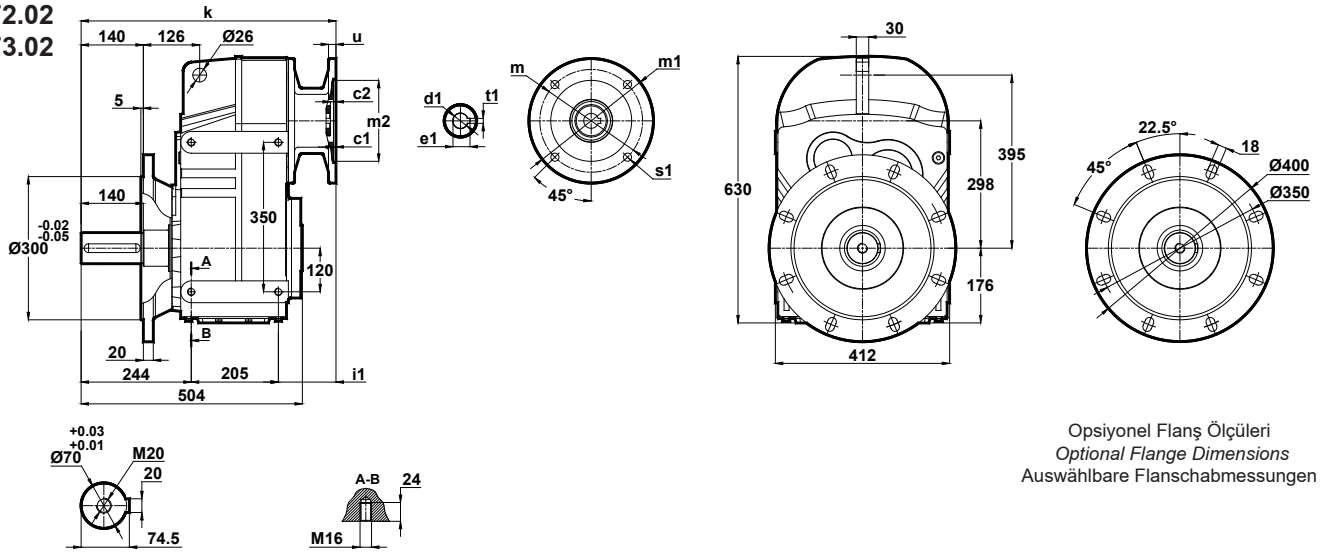

Opsiyonel Flanş Ölçüleri  
Optional Flange Dimensions  
Auswählbare Flanschabmessungen

	c1	c2	s1	m	m1	m2(H7)	i1	u	k	d1	t1	e1
100/B5	5	20	15	215	250	180	94	15	544	28	8	31.3
112/B5	5	20	15	215	250	180	94	15	544	28	8	31.3
132/B5	5	9	15	265	300	230	115	15	565	38	10	41.3
132/B14	4.5	9	11	165	200	130	115	15	565	38	10	41.3
160/B5	5.5	10	19	300	350	250	191	18	640	42	12	45.3
180/B5	6	10	19	300	350	250	191	18	640	48	14	51.8
200/B5	6	10	19	350	400	300	211	22	660	55	16	59.3

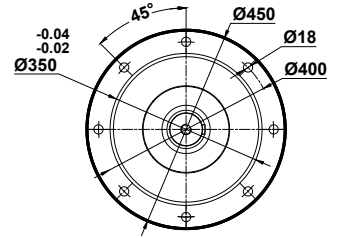

Diğer opsiyonel flanş ölçüleri için sayfa 326'ya bakınız.  
Please see on page 326 for other optional flange dimensions  
Siehe Seite 326 für andere auswählbare Flanschabmessungen

DN672.03  
DN673.03

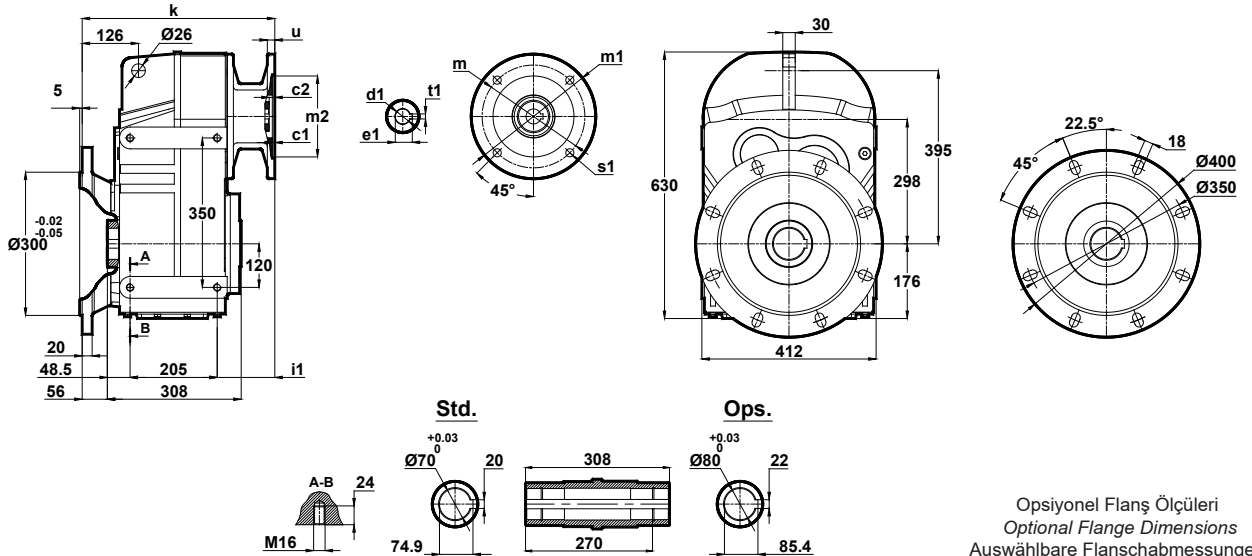

Opsiyonel Flanş Ölçüleri  
Optional Flange Dimensions  
Auswählbare Flanschabmessungen

	c1	c2	s1	m	m1	m2(H7)	i1	u	k	d1	t1	e1
100/B5	5	20	15	215	250	180	94	15	404	28	8	31.3
112/B5	5	20	15	215	250	180	94	15	404	28	8	31.3
132/B5	5	9	15	265	300	230	115	15	425	38	10	41.3
132/B14	4.5	9	11	165	200	130	115	15	425	38	10	41.3
160/B5	5.5	10	19	300	350	250	191	18	500	42	12	45.3
180/B5	6	10	19	300	350	250	191	18	500	48	14	51.8
200/B5	6	10	19	350	400	300	211	22	520	55	16	59.3

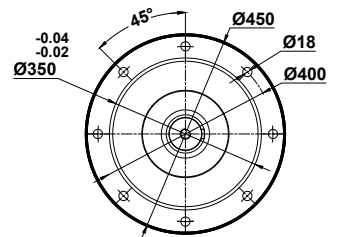

Diğer opsiyonel flanş ölçüleri için sayfa 326'ya bakınız.  
Please see on page 326 for other optional flange dimensions  
Siehe Seite 326 für andere auswählbare Flanschabmessungen

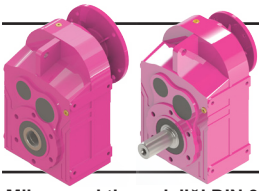

# Ölçü Sayfaları Dimension Pages Abmessungenseiten

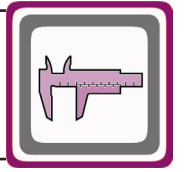

Mil ucu çekirtme deliği DIN 332 sayfa 2 / Tapped center hole according to DIN 332, sheet 2 / Zentrierung mit Gewinde nach DIN 332, Blatt 2

## DN674.00

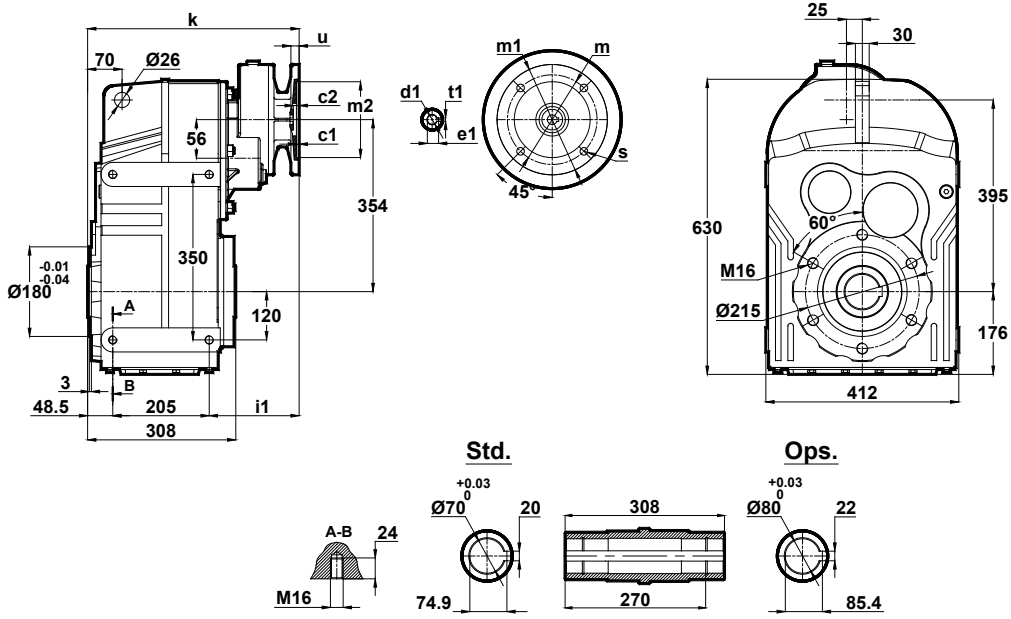

	c1	c2	s1	m	m1	m2(H7)	i1	u	k	d1	t1	e1
71/B5	4	9	11	130	160	110	174	12	428	14	5	16.3
80/B5 80/B14	4	9	12 7	165 100	200 120	130 80	174	12	428	19	6	21.8
90/B5 90/B14	4	9	12 9	165 115	200 140	130 95	174	12	428	24	8	27.3

## DN674.01

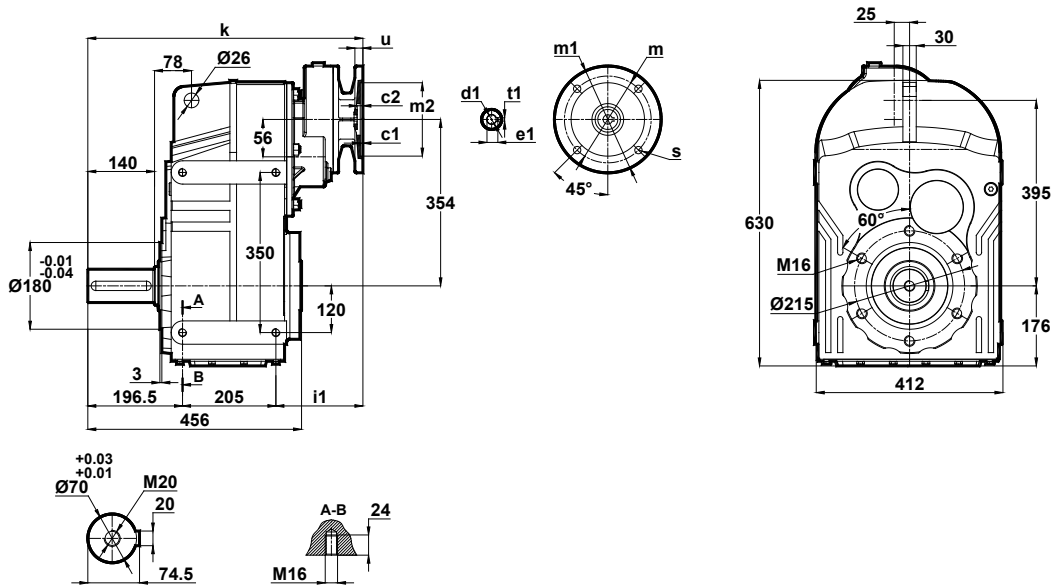

	c1	c2	s1	m	m1	m2(H7)	i1	u	k	d1	t1	e1
71/B5	4	9	11	130	160	110	174	12	576	14	5	16.3
80/B5 80/B14	4	9	12 7	165 100	200 120	130 80	174	12	576	19	6	21.8
90/B5 90/B14	4	9	12 9	165 115	200 140	130 95	174	12	576	24	8	27.3

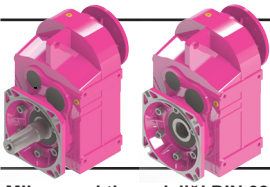

# Ölçü Sayfaları Dimension Pages Abmessungenseiten

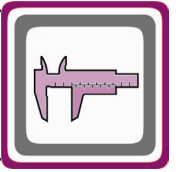

Mil ucu çektirme deliği DIN 332 sayfa 2 / Tapped center hole according to DIN 332, sheet 2 / Zentrierung mit Gewinde nach DIN 332, Blatt 2

## DN674.02

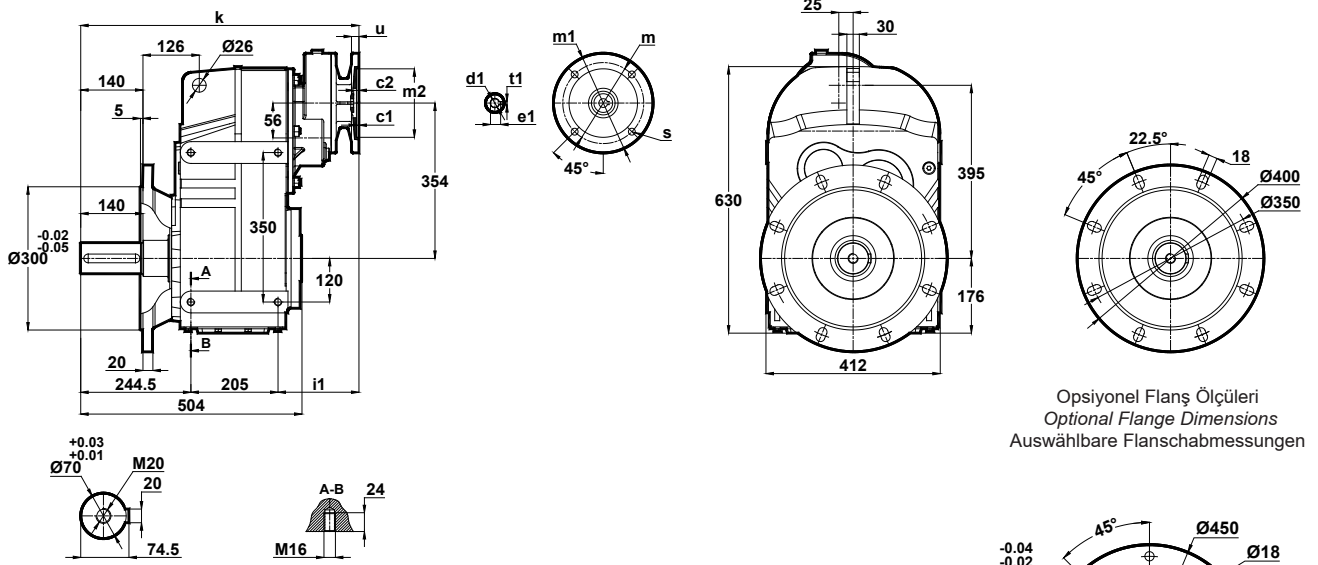

Opsiyonel Flanş Ölçüleri  
Optional Flange Dimensions  
Auswählbare Flanschabmessungen

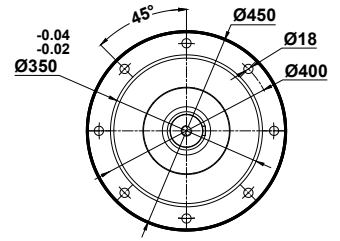

	c1	c2	s1	m	m1	m2(H7)	i1	u	k	d1	t1	e1
71/B5	4	9	11	130	160	110	174	12	624	14	5	16.3
80/B5 80/B14	4	9	12 7	165 100	200 120	130 80	174	12	624	19	6	21.8
90/B5 90/B14	4	9	12 9	165 115	200 140	130 95	174	12	624	24	8	27.3

Diğer opsiyonel flanş ölçüleri için sayfa 326'ya bakınız.  
Please see on page 326 for other optional flange dimensions  
Siehe Seite 326 für andere auswählbare Flanschabmessungen

## DN674.03

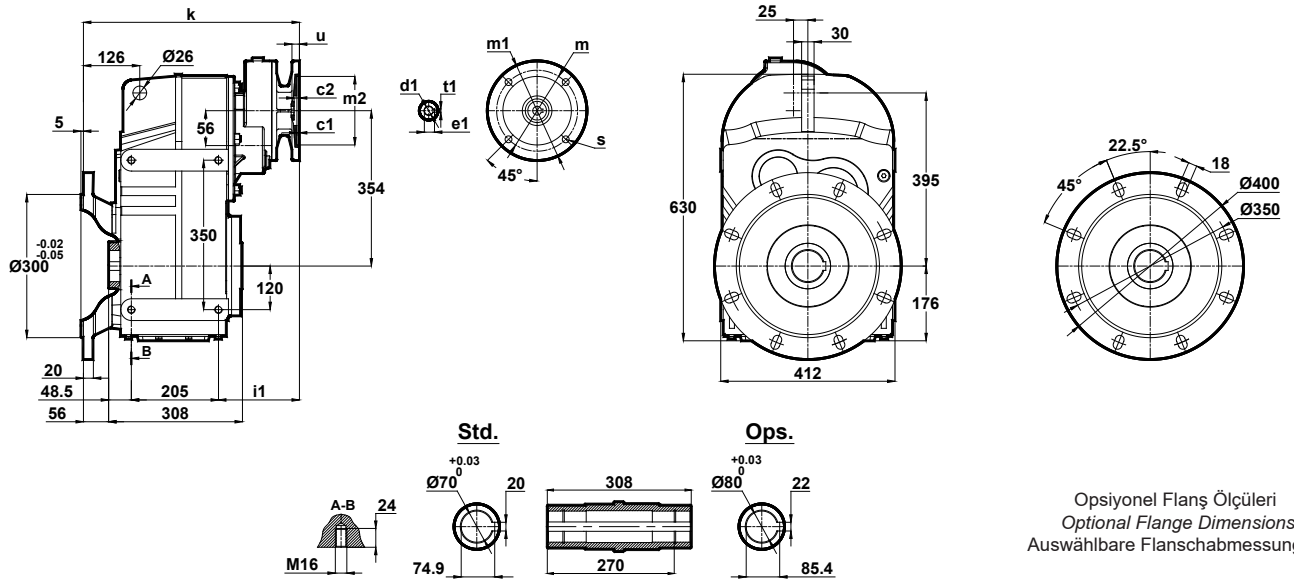

Opsiyonel Flanş Ölçüleri  
Optional Flange Dimensions  
Auswählbare Flanschabmessungen

	c1	c2	s1	m	m1	m2(H7)	i1	u	k	d1	t1	e1
71/B5	4	9	11	130	160	110	174	12	484	14	5	16.3
80/B5 80/B14	4	9	12 7	165 100	200 120	130 80	174	12	484	19	6	21.8
90/B5 90/B14	4	9	12 9	165 115	200 140	130 95	174	12	484	24	8	27.3

Diğer opsiyonel flanş ölçüleri için sayfa 326'ya bakınız.  
Please see on page 326 for other optional flange dimensions  
Siehe Seite 326 für andere auswählbare Flanschabmessungen

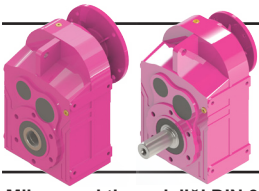

# Ölçü Sayfaları Dimension Pages Abmessungsseiten

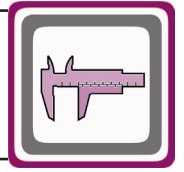

Mil ucu çektirme deliği DIN 332 sayfa 2 / Tapped center hole according to DIN 332, sheet 2 / Zentrierung mit Gewinde nach DIN 332, Blatt 2

DN675.00  
DN676.00

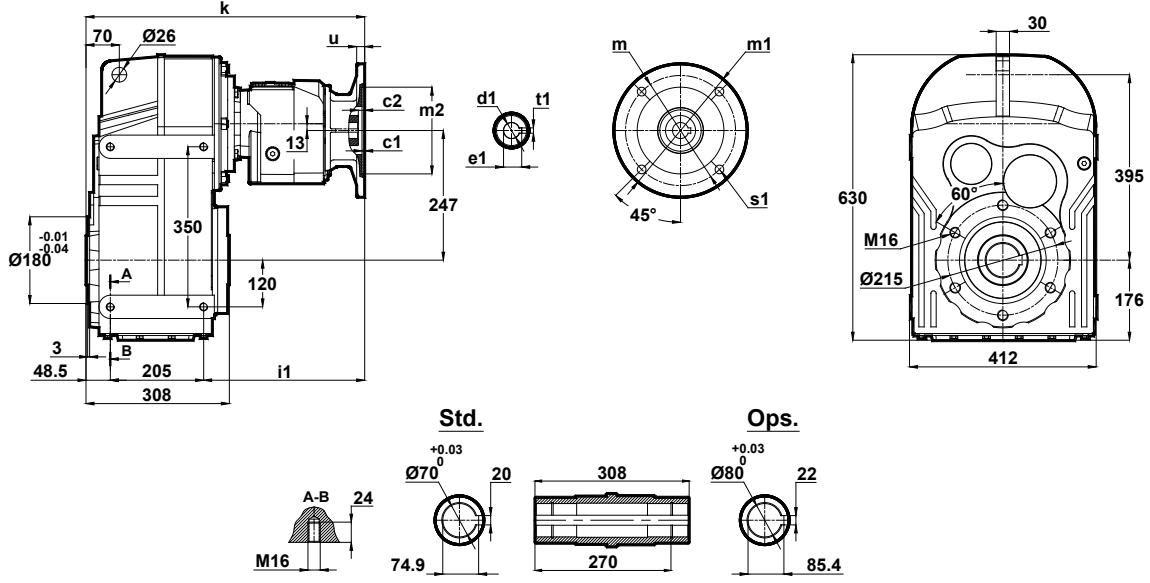

	c1	c2	s1	m	m1	m2(H7)	i1	u	k	d1	t1	e1
63/B5	4	8	9	115	140	95	304	12	558	11	4	12.8
71/B5	4	9	11	130	160	110	275	12	529	14	5	16.3
71/B14	3	8.5	7	85	105	70	70	10	529	14	5	16.3
80/B5	4	5	12	165	200	130	304	12	558	19	6	21.8
80/B14	4	5	7	100	120	80	80	12	558	19	6	21.8

DN675.01  
DN676.01

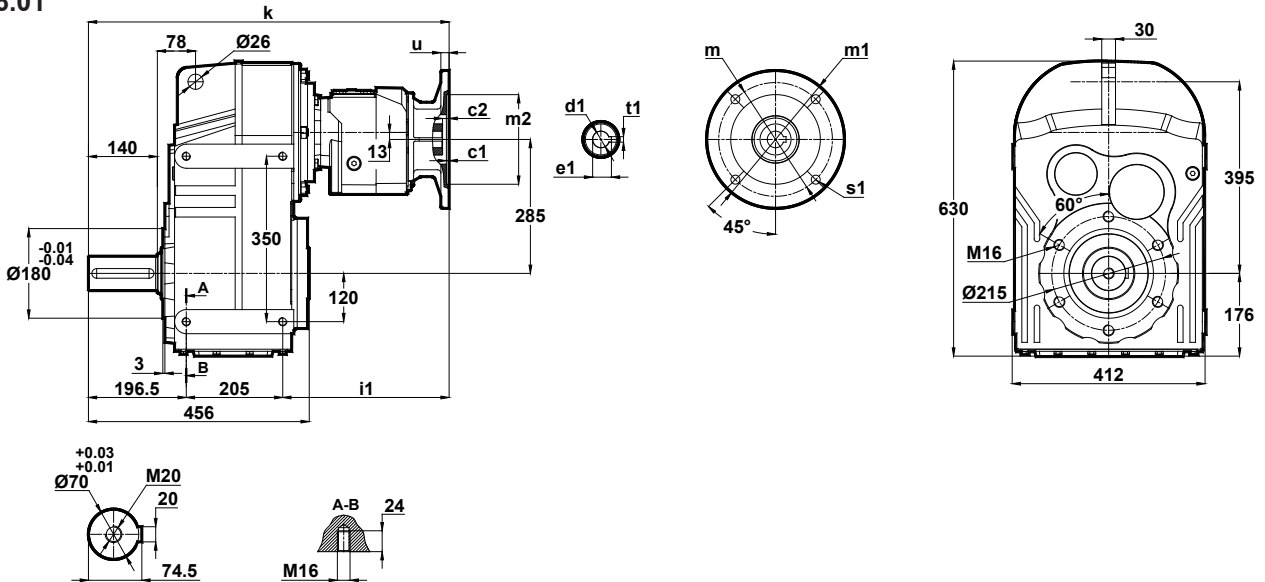

	c1	c2	s1	m	m1	m2(H7)	i1	u	k	d1	t1	e1
63/B5	4	8	9	115	140	95	304	12	706	11	4	12.8
71/B5	4	9	11	130	160	110	275	12	677	14	5	16.3
71/B14	3	8.5	7	85	105	70	70	10	677	14	5	16.3
80/B5	4	5	12	165	200	130	304	12	706	19	6	21.8
80/B14	4	5	7	100	120	80	80	12	706	19	6	21.8

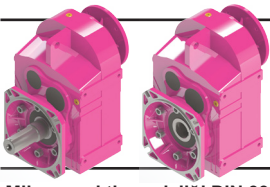

# Ölçü Sayfaları Dimension Pages Abmessungsseiten

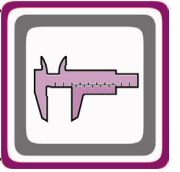

Mil ucu çektirme deliği DIN 332 sayfa 2 / Tapped center hole according to DIN 332, sheet 2 / Zentrierung mit Gewinde nach DIN 332, Blatt 2

DN675.02  
DN676.02

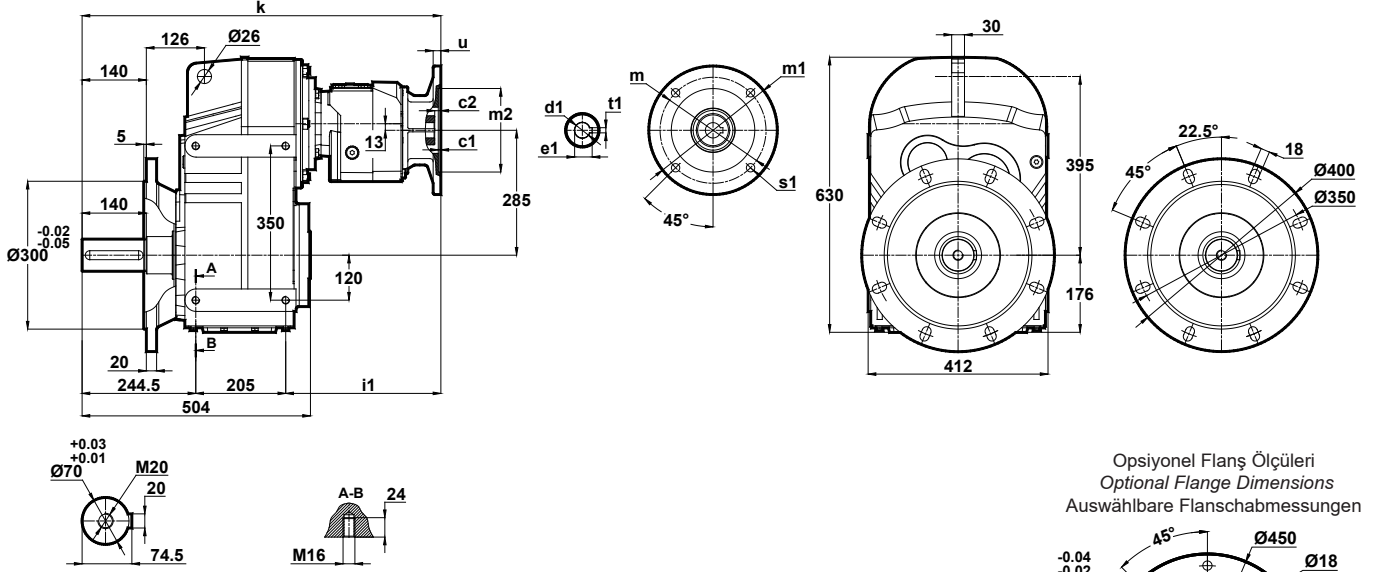

Opsiyonel Flanş Ölçüleri  
Optional Flange Dimensions  
Auswählbare Flanschabmessungen

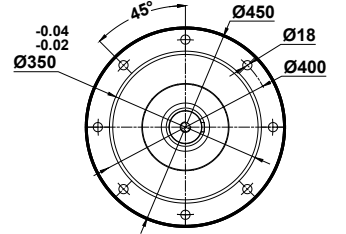

Diğer opsiyonel flanş ölçüleri için sayfa 326'ya bakınız.  
Please see on page 326 for other optional flange dimensions  
Siehe Seite 326 für andere auswählbare Flanschabmessungen

DN675.03  
DN676.03

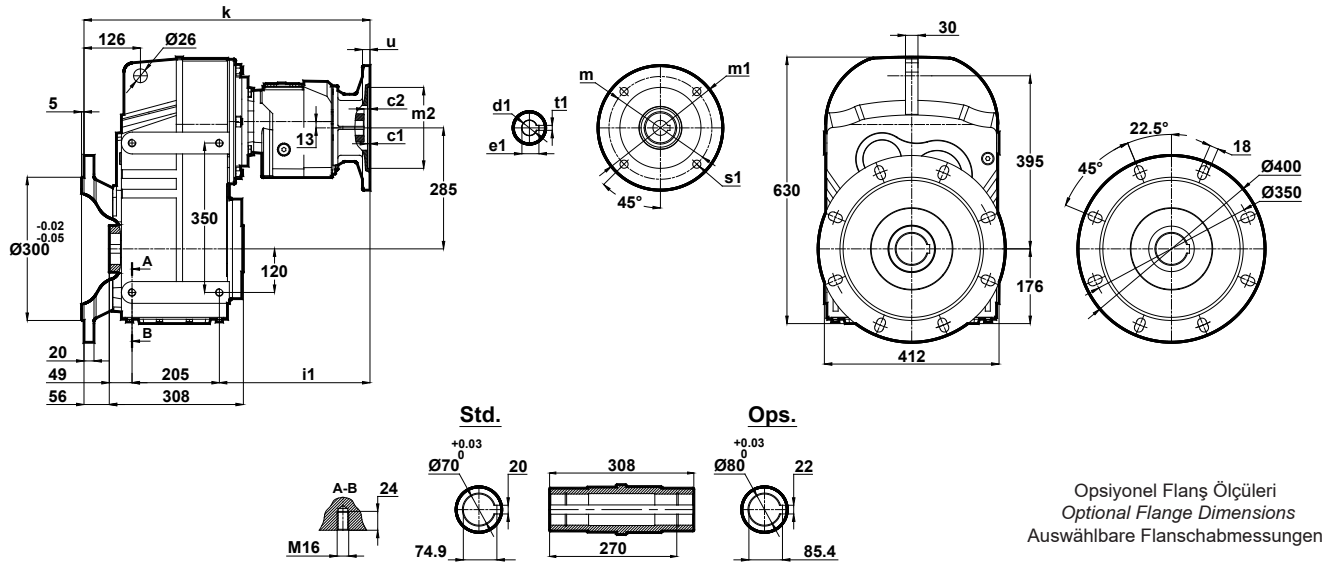

Opsiyonel Flanş Ölçüleri  
Optional Flange Dimensions  
Auswählbare Flanschabmessungen

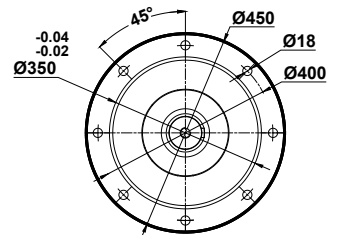

Diğer opsiyonel flanş ölçüleri için sayfa 326'ya bakınız.  
Please see on page 326 for other optional flange dimensions  
Siehe Seite 326 für andere auswählbare Flanschabmessungen

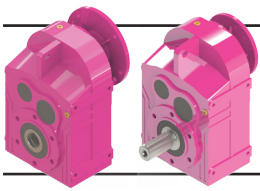

# Ölçü Sayfaları

## Dimension Pages

### Abmessungsseiten

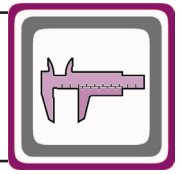

Mil ucu çekirtme deliği DIN 332 sayfa 2 / Tapped center hole according to DIN 332, sheet 2 / Zentrierung mit Gewinde nach DIN 332, Blatt 2

DN772.00  
DN773.00

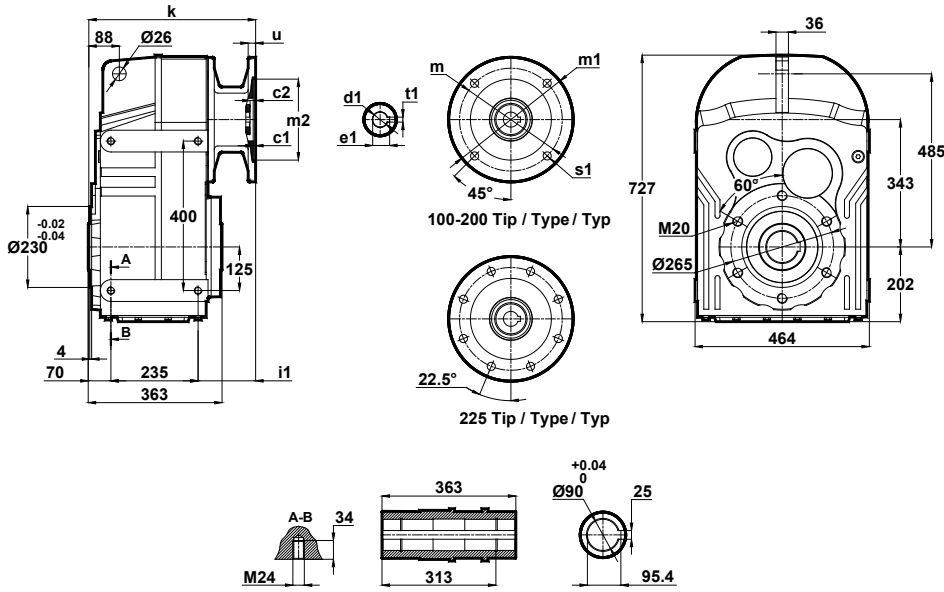

	c1	c2	s1	m	m1	m2(H7)	i1	u	k	d1	t1	e1
100/B5	5	15	15	215	250	180	85	15	390	28	8	31.3
112/B5	5	15	15	215	250	180	85	15	390	28	8	31.3
132/B5	5	9	15	265	300	230	100	15	405	38	10	41.3
132/B14	4.5	9	15	165	200	130	100	15	405	38	10	41.3
160/B5	5.5	10	19	300	350	250	175	20	480	42	12	45.3
180/B5	6	10	19	300	350	250	175	20	480	48	14	51.8
200/B5	6	10	19	350	400	300	196	22	500	55	16	59.3
225/B5	5.5	10	19	400	450	350	249	24	553	60	18	64.4

DN772.01  
DN773.01

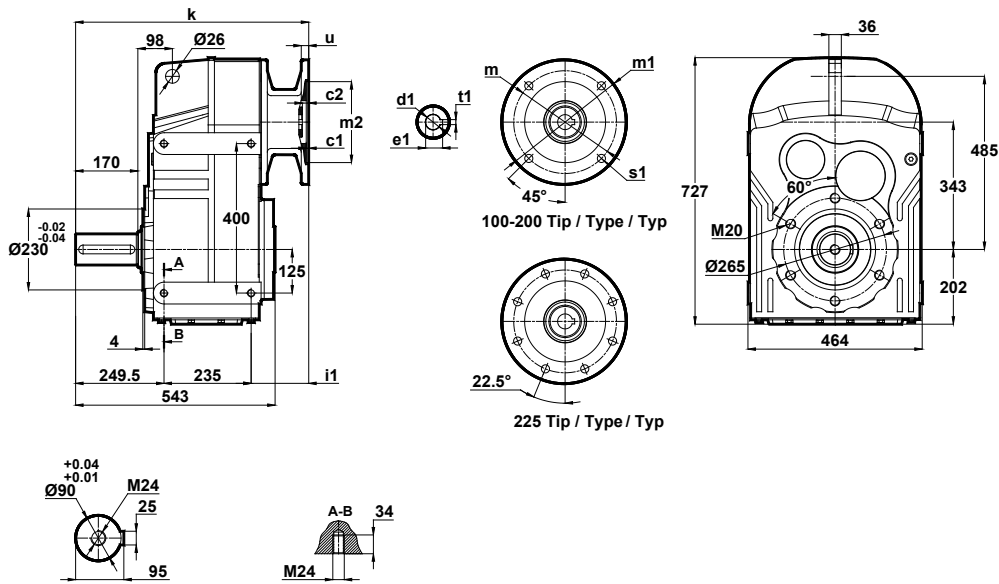

	c1	c2	s1	m	m1	m2(H7)	i1	u	k	d1	t1	e1
100/B5	5	15	15	215	250	180	85	15	570	28	8	31.3
112/B5	5	15	15	215	250	180	85	15	570	28	8	31.3
132/B5	5	9	15	265	300	230	100	15	585	38	10	41.3
132/B14	4.5	9	15	165	200	130	100	15	585	38	10	41.3
160/B5	5.5	10	19	300	350	250	175	20	660	42	12	45.3
180/B5	6	10	19	300	350	250	175	20	660	48	14	51.8
200/B5	6	10	19	350	400	300	196	22	680	55	16	59.3
225/B5	5.5	10	19	400	450	350	249	24	733	60	18	64.4

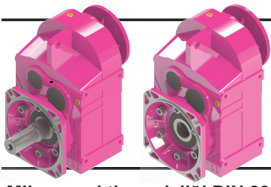

# Ölçü Sayfaları Dimension Pages Abmessungsseiten

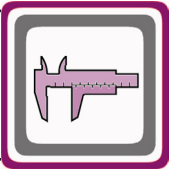

Mil ucu çektirme deliği DIN 332 sayfa 2 / Tapped center hole according to DIN 332, sheet 2 / Zentrierung mit Gewinde nach DIN 332, Blatt 2

DN772.02  
DN773.02

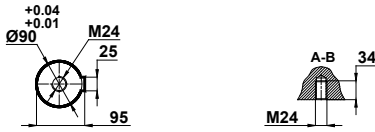
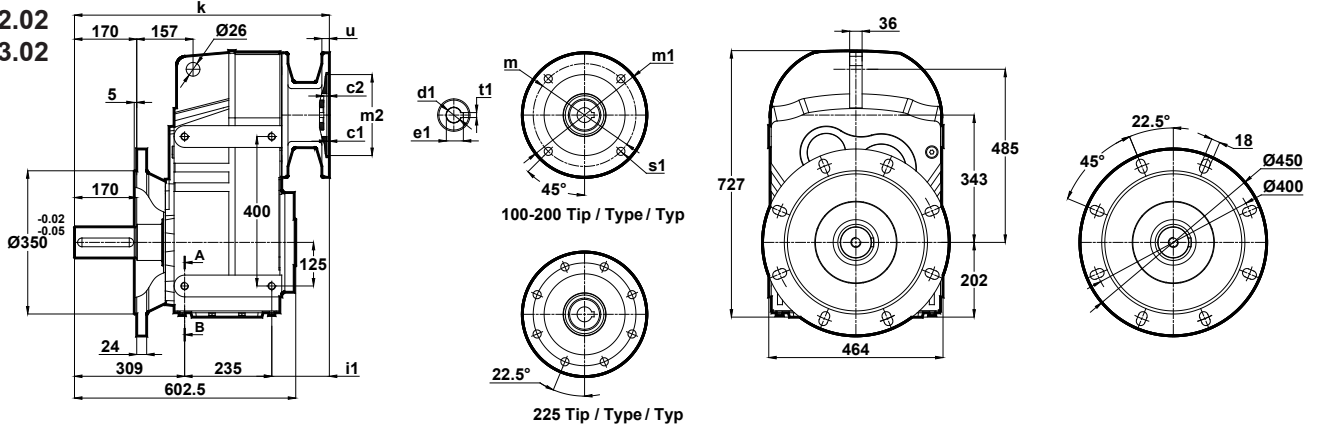

Opsiyonel flanş ölçüleri için sayfa 326'ya bakınız.  
Please see on page 326 for optional flange dimensions  
Siehe Seite 326 für auswählbare Flanschabmessungen

	c1	c2	s1	m	m1	m2(H7)	i1	u	k	d1	t1	e1
100/B5	5	15	15	215	250	180	85	15	630	28	8	31.3
112/B5	5	15	15	215	250	180	85	15	630	28	8	31.3
132/B5	5	9	15	265	300	230	100	15	645	38	10	41.3
132/B14	4.5			165	200	130						
160/B5	5.5	10	19	300	350	250	175	20	720	42	12	45.3
180/B5	6	10	19	300	350	250	175	20	720	48	14	51.8
200/B5	6	10	19	350	400	300	196	22	740	55	16	59.3
225/B5	5.5	10	19	400	450	350	249	24	793	60	18	64.4

DN772.03  
DN773.03

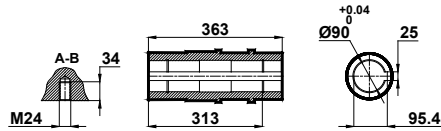
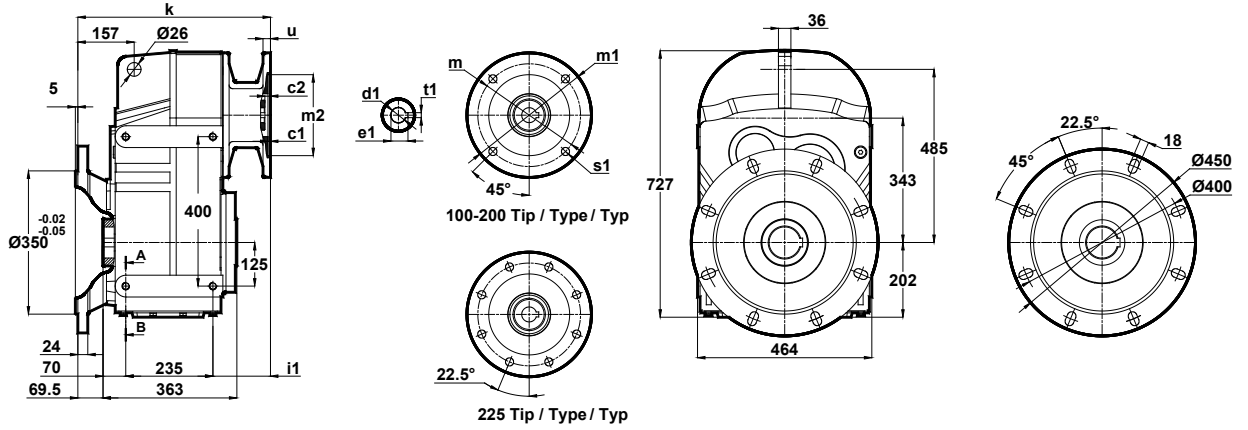

Opsiyonel flanş ölçüleri için sayfa 326'ya bakınız.  
Please see on page 326 for optional flange dimensions  
Siehe Seite 326 für auswählbare Flanschabmessungen

	c1	c2	s1	m	m1	m2(H7)	i1	u	k	d1	t1	e1
100/B5	5	15	15	215	250	180	85	15	460	28	8	31.3
112/B5	5	15	15	215	250	180	85	15	460	28	8	31.3
132/B5	5	9	15	265	300	230	100	15	475	38	10	41.3
132/B14	4.5			165	200	130						
160/B5	5.5	10	19	300	350	250	175	20	550	42	12	45.3
180/B5	6	10	19	300	350	250	175	20	550	48	14	51.8
200/B5	6	10	19	350	400	300	196	22	570	55	16	59.3
225/B5	5.5	10	19	400	450	350	249	24	623	60	18	64.4

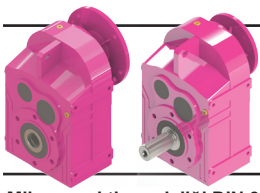

# Ölçü Sayfaları

## Dimension Pages

## Abmessungsseiten

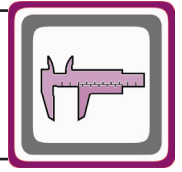

Mil ucu çektirme deliği DIN 332 sayfa 2 / Tapped center hole according to DIN 332, sheet 2 / Zentrierung mit Gewinde nach DIN 332, Blatt 2

### DN774.00

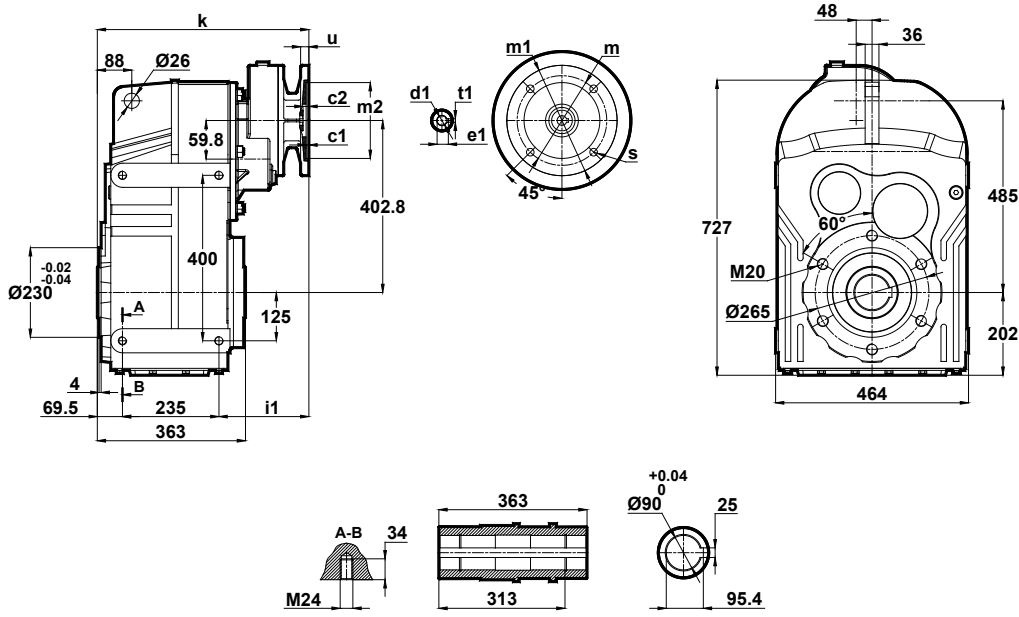

	c1	c2	s1	m	m1	m2(H7)	i1	u	k	d1	t1	e1
80/B5	4	5	12	165	200	130	175	12	480	19	6	21.8
90/B5 90/B14	4	5	12 9	165 115	200 140	130 95	175	12	480	24	8	27.3
100/B5 100/B14	5 4	9	15 9	215 130	250 160	180 110	194	15	498	28	8	31.3

### DN774.01

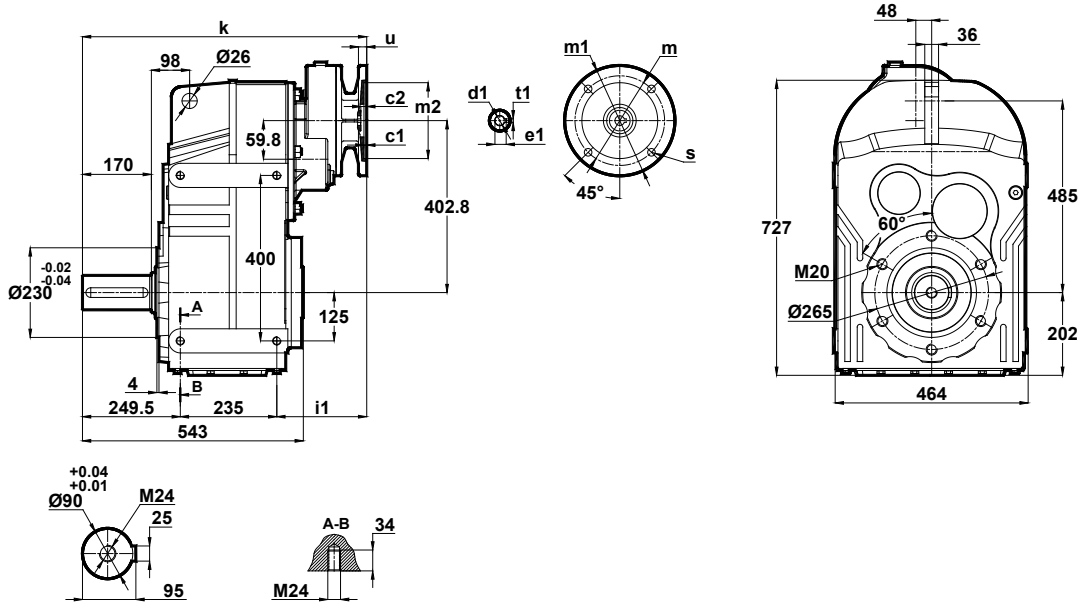

	c1	c2	s1	m	m1	m2(H7)	i1	u	k	d1	t1	e1
80/B5	4	5	12	165	200	130	175	12	660	19	6	21.8
90/B5 90/B14	4	5	12 9	165 115	200 140	130 95	175	12	660	24	8	27.3
100/B5 100/B14	5 4	9	15 9	215 130	250 160	180 110	194	15	678	28	8	31.3

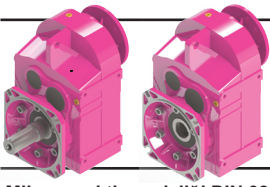

# Ölçü Sayfaları Dimension Pages Abmessungenseiten

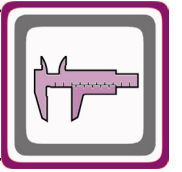

Mil ucu çektirme deliği DIN 332 sayfa 2 / Tapped center hole according to DIN 332, sheet 2 / Zentrierung mit Gewinde nach DIN 332, Blatt 2

## DN774.02

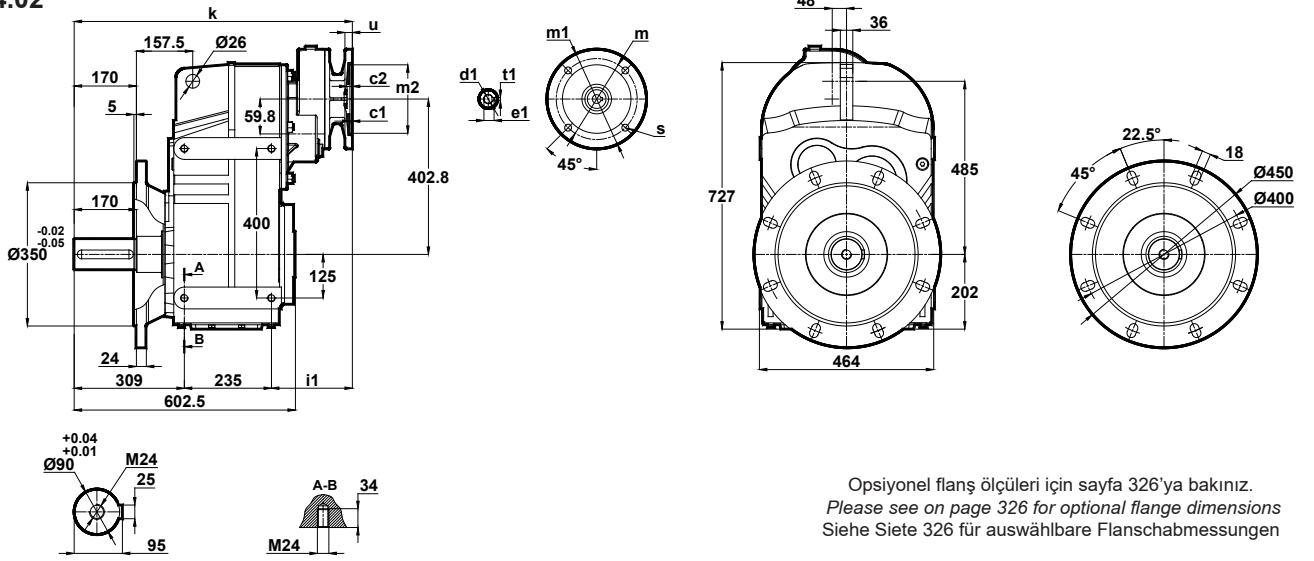

	c1	c2	s1	m	m1	m2(H7)	i1	u	k	d1	t1	e1
80/B5	4	5	12	165	200	130	175	12	720	19	6	21.8
90/B5 90/B14	4	5	12 9	165 115	200 140	130 95	175	12	720	24	8	27.3
100/B5 100/B14	5 4	9	15 9	215 130	250 160	180 110	194	15	738	28	8	31.3

## DN774.03

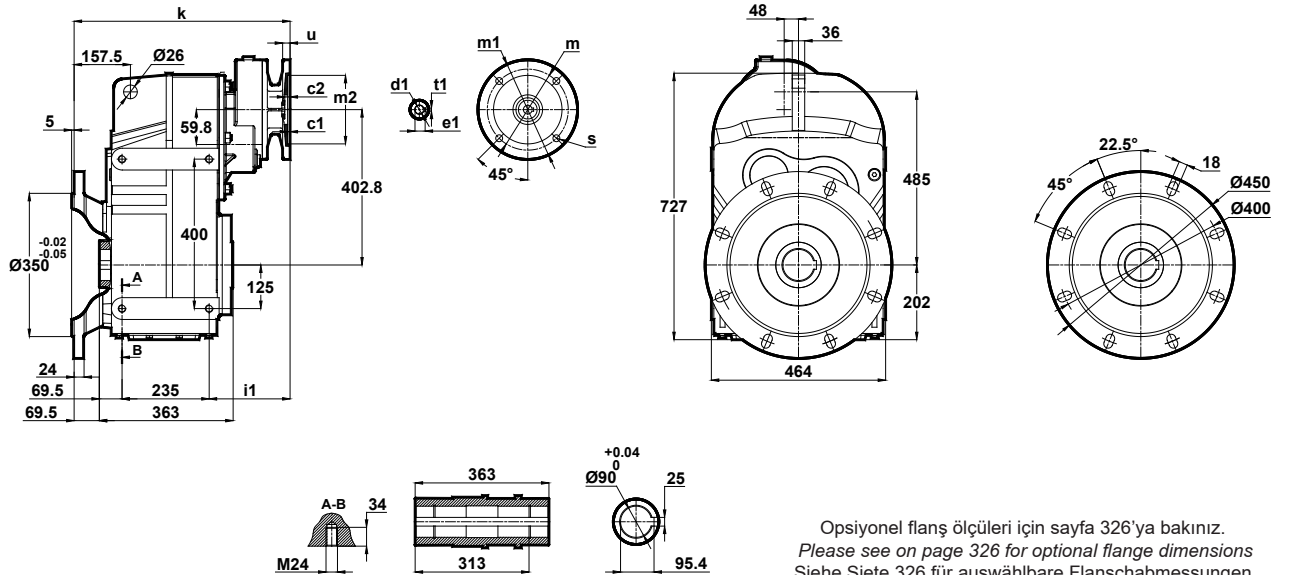

	c1	c2	s1	m	m1	m2(H7)	i1	u	k	d1	t1	e1
80/B5	4	5	12	165	200	130	175	12	550	19	6	21.8
90/B5 90/B14	4	5	12 9	165 115	200 140	130 95	175	12	550	24	8	27.3
100/B5 100/B14	5 4	9	15 9	215 130	250 160	180 110	194	15	568	28	8	31.3

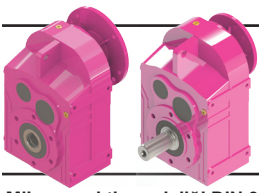

# Ölçü Sayfaları

## Dimension Pages

### Abmessungsseiten

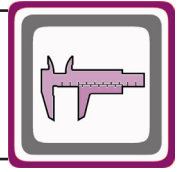

Mil ucu çektirme deliği DIN 332 sayfa 2 / Tapped center hole according to DIN 332, sheet 2 / Zentrierung mit Gewinde nach DIN 332, Blatt 2

DN775.00  
DN776.00

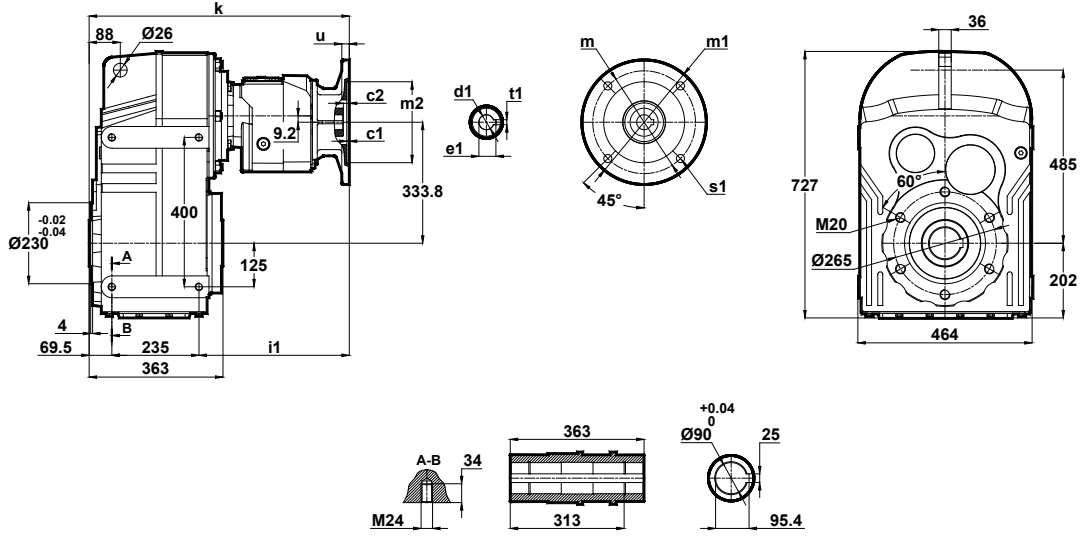

	c1	c2	s1	m	m1	m2(H7)	i1	u	k	d1	t1	e1
71/B5	4	9	11	130	160	110	326	12	630	14	5	16.3
80/B5	4	9	12	165	200	130	326	12	630	19	6	21.8
80/B14	4	9	7	100	120	80	326	12	630	19	6	21.8
90/B5	4	9	12	165	200	130	326	12	630	24	8	27.3
90/B14	4	9	9	115	140	95	326	12	630	24	8	27.3

DN775.01  
DN776.01

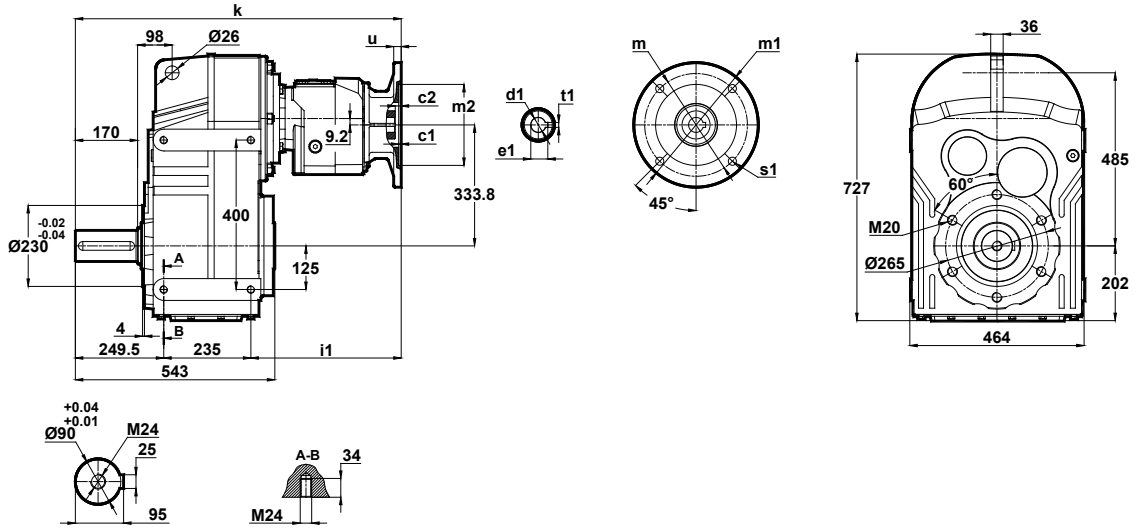

	c1	c2	s1	m	m1	m2(H7)	i1	u	k	d1	t1	e1
71/B5	4	9	11	130	160	110	326	12	810	14	5	16.3
80/B5	4	9	12	165	200	130	326	12	810	19	6	21.8
80/B14	4	9	7	100	120	80	326	12	810	19	6	21.8
90/B5	4	9	12	165	200	130	326	12	810	24	8	27.3
90/B14	4	9	9	115	140	95	326	12	810	24	8	27.3

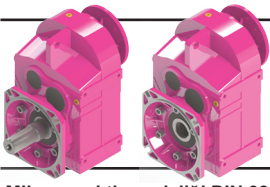

# Ölçü Sayfaları Dimension Pages Abmessungenseiten

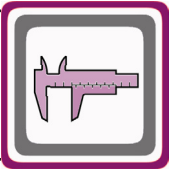

Mil ucu çektirme deliği DIN 332 sayfa 2 / Tapped center hole according to DIN 332, sheet 2 / Zentrierung mit Gewinde nach DIN 332, Blatt 2

DN775.02  
DN776.02

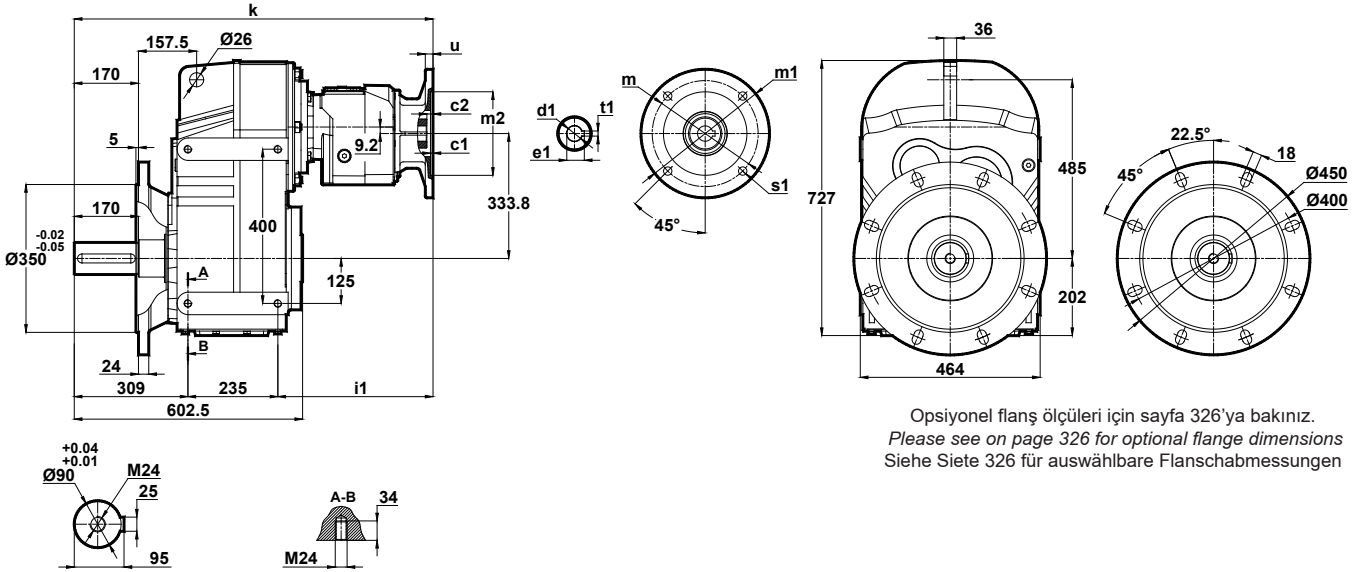

Opsiyonel flanş ölçüleri için sayfa 326'ya bakınız.  
Please see on page 326 for optional flange dimensions  
Siehe Seite 326 für auswählbare Flanschabmessungen

	c1	c2	s1	m	m1	m2(H7)	i1	u	k	d1	t1	e1
71/B5	4	9	11	130	160	110	326	12	870	14	5	16.3
80/B5 80/B14	4	9	12 7	165 100	200 120	130 80	326	12	870	19	6	21.8
90/B5 90/B14	4	9	12 9	165 115	200 140	130 95	326	12	870	24	8	27.3

DN775.03  
DN776.03

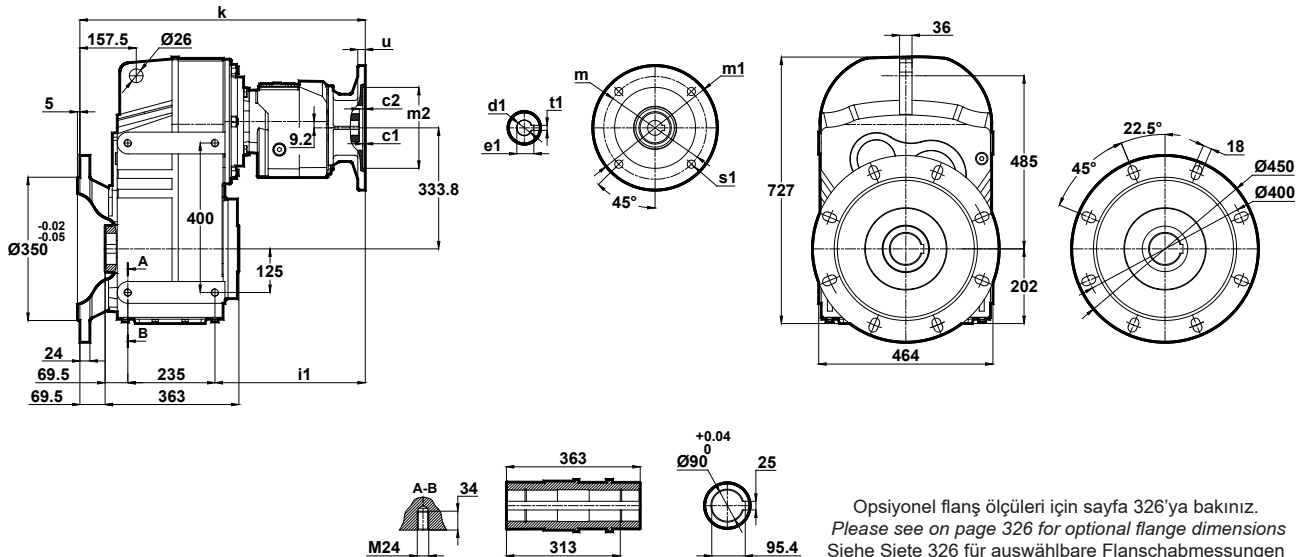

Opsiyonel flanş ölçüleri için sayfa 326'ya bakınız.  
Please see on page 326 for optional flange dimensions  
Siehe Seite 326 für auswählbare Flanschabmessungen

	c1	c2	s1	m	m1	m2(H7)	i1	u	k	d1	t1	e1
71/B5	4	9	11	130	160	110	326	12	700	14	5	16.3
80/B5 80/B14	4	9	12 7	165 100	200 120	130 80	326	12	700	19	6	21.8
90/B5 90/B14	4	9	12 9	165 115	200 140	130 95	326	12	700	24	8	27.3

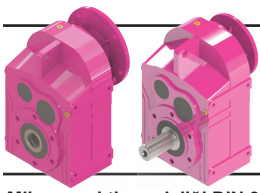

# Ölçü Sayfaları Dimension Pages Abmessungsseiten

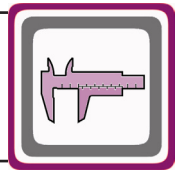

Mil ucu çektirme deliği DIN 332 sayfa 2 / Tapped center hole according to DIN 332, sheet 2 / Zentrierung mit Gewinde nach DIN 332, Blatt 2

DN872.00  
DN873.00

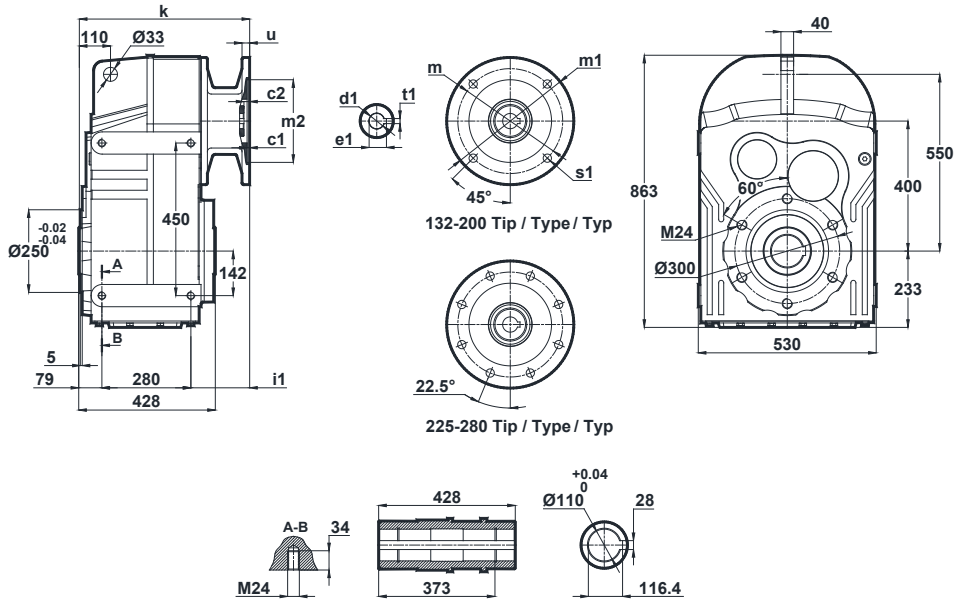

	c1	c2	s1	m	m1	m2(H7)	i1	u	k	d1	t1	e1
132/B5	5	14	15	265	300	230	98	15	457	38	10	41.3
160/B5	5.5	10	19	300	350	250	243	20	602	42	12	45.3
180/B5	6	10	19	300	350	250	243	20	602	48	14	51.8
200/B5	6	10	19	350	400	300	243	22	602	55	16	59.3
225/B5	5.5	10	19	400	450	350	243	24	602	60	18	64.4
250/B5	6	10	19	500	550	450	243	24	602	65	18	69.4
280/B5	6	10	19	500	550	450	243	24	602	75	20	79.4

DN872.01  
DN873.01

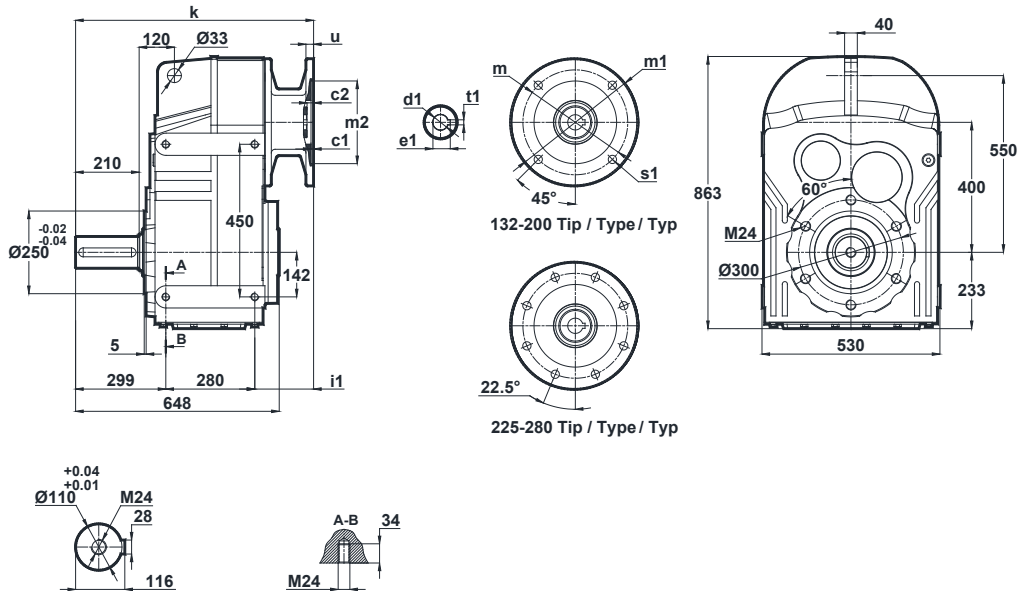

	c1	c2	s1	m	m1	m2(H7)	i1	u	k	d1	t1	e1
132/B5	5	14	15	265	300	230	98	15	677	38	10	41.3
160/B5	5.5	10	19	300	350	250	243	20	822	42	12	45.3
180/B5	6	10	19	300	350	250	243	20	822	48	14	51.8
200/B5	6	10	19	350	400	300	243	22	822	55	16	59.3
225/B5	5.5	10	19	400	450	350	243	24	822	60	18	64.4
250/B5	6	10	19	500	550	450	243	24	822	65	18	69.4
280/B5	6	10	19	500	550	450	243	24	822	75	20	79.4

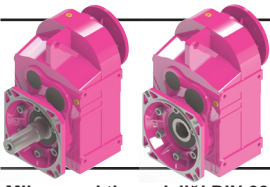

# Ölçü Sayfaları Dimension Pages Abmessungsseiten

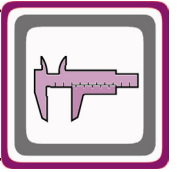

Mil ucu çektirme deliği DIN 332 sayfa 2 / Tapped center hole according to DIN 332, sheet 2 / Zentrierung mit Gewinde nach DIN 332, Blatt 2

DN872.02

DN873.02

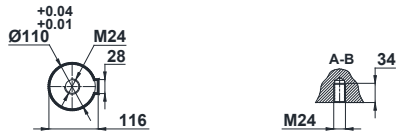
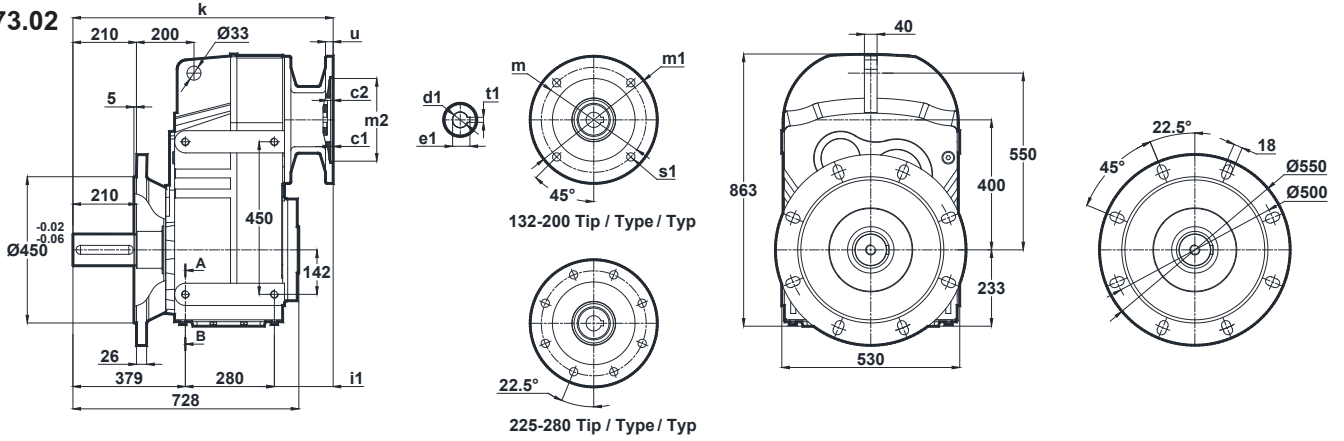

Opsiyonel flanş ölçüleri için sayfa 326'ya bakınız.  
Please see on page 326 for optional flange dimensions  
Siehe Seite 326 für auswählbare Flanschabmessungen

	c1	c2	s1	m	m1	m2(H7)	i1	u	k	d1	t1	e1
132/B5	5	14	15	265	300	230	98	15	757	15	10	41.3
160/B5	5.5	10	19	300	350	250	243	20	902	42	12	45.3
180/B5	6	10	19	300	350	250	243	20	902	48	14	51.8
200/B5	6	10	19	350	400	300	243	22	902	55	16	59.3
225/B5	5.5	10	19	400	450	350	243	24	902	60	18	64.4
250/B5	6	10	19	500	550	450	243	24	902	65	18	69.4
280/B5	6	10	19	500	550	450	243	24	902	75	20	79.4

DN872.03

DN873.03

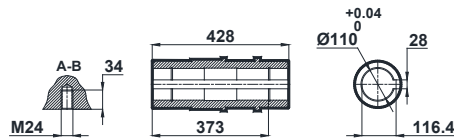
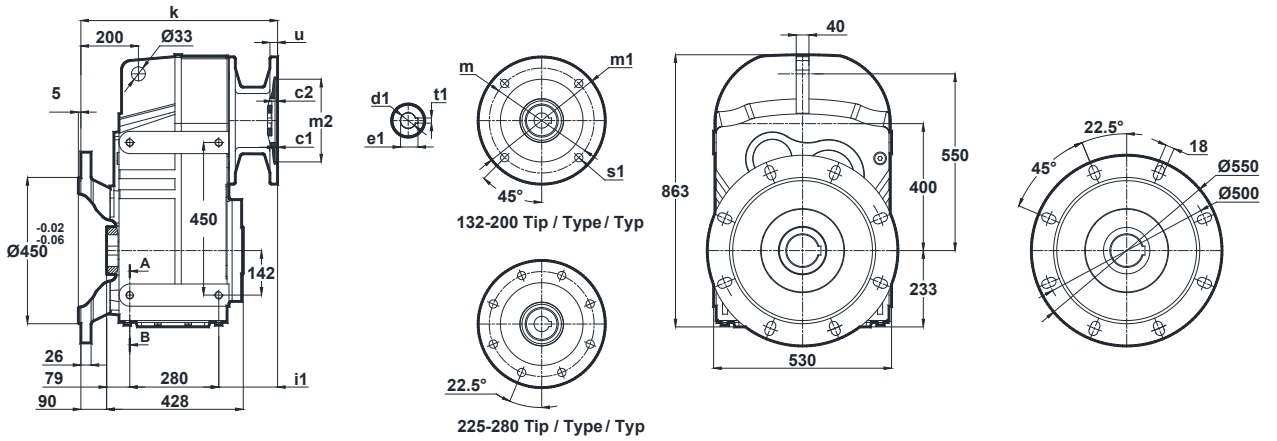

Opsiyonel flanş ölçüleri için sayfa 326'ya bakınız.  
Please see on page 326 for optional flange dimensions  
Siehe Seite 326 für auswählbare Flanschabmessungen

	c1	c2	s1	m	m1	m2(H7)	i1	u	k	d1	t1	e1
132/B5	5	14	15	265	300	230	98	15	547	38	10	41.3
160/B5	5.5	10	19	300	350	250	243	20	692	42	12	45.3
180/B5	6	10	19	300	350	250	243	20	692	48	14	51.8
200/B5	6	10	19	350	400	300	243	22	692	55	16	59.3
225/B5	5.5	10	19	400	450	350	243	24	692	60	18	64.4
250/B5	6	10	19	500	550	450	243	24	692	65	18	69.4
280/B5	6	10	19	500	550	450	243	24	692	75	20	79.4

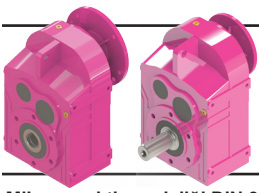

# Ölçü Sayfaları

## Dimension Pages

### Abmessungsseiten

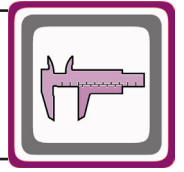

Mil ucu çekirme deliği DIN 332 sayfa 2 / Tapped center hole according to DIN 332, sheet 2 / Zentrierung mit Gewinde nach DIN 332, Blatt 2

#### DN874.00

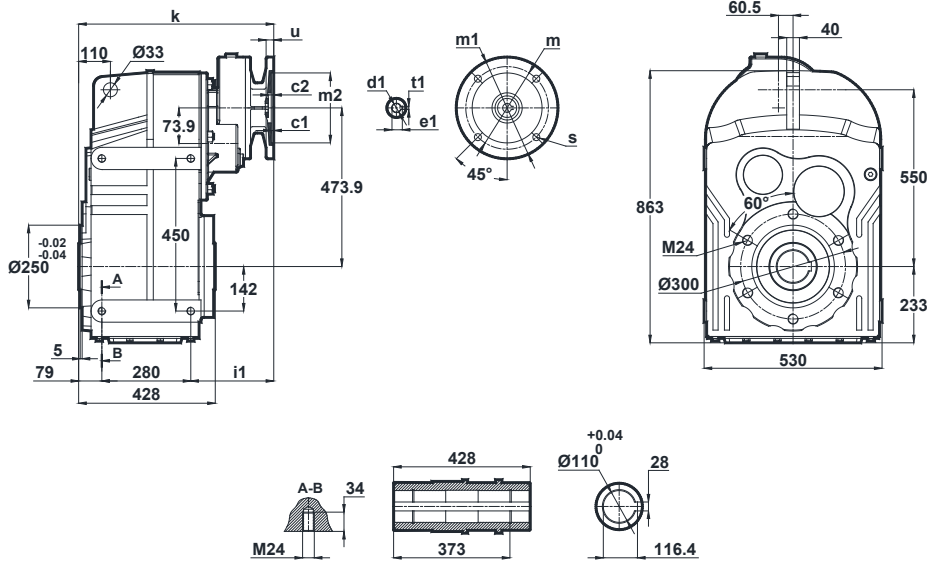

	c1	c2	s1	m	m1	m2(H7)	i1	u	k	d1	t1	e1
100/B5	5	20	15	215	250	180	215	15	575	28	8	31.3
112/B5	5	20	15	215	250	180	215	15	575	28	8	31.3
132/B5	5	9	15	265	300	230	236	15	596	38	10	41.3
132/B14	4.5		11	165	200	130						

#### DN874.01

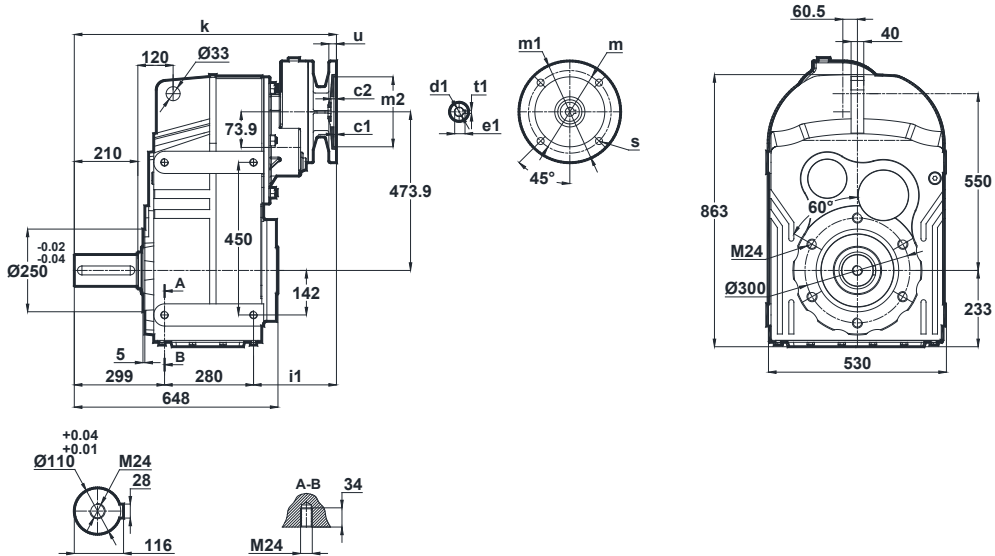

	c1	c2	s1	m	m1	m2(H7)	i1	u	k	d1	t1	e1
100/B5	5	20	15	215	250	180	215	15	795	28	8	31.3
112/B5	5	20	15	215	250	180	215	15	795	28	8	31.3
132/B5	5	9	15	265	300	230	236	15	816	38	10	41.3
132/B14	4.5		11	165	200	130						

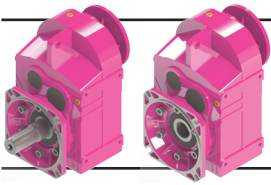

# Ölçü Sayfaları Dimension Pages Abmessungsseiten

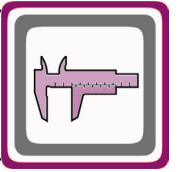

Mil ucu çektirme deliği DIN 332 sayfa 2 / Tapped center hole according to DIN 332, sheet 2 / Zentrierung mit Gewinde nach DIN 332, Blatt 2

## DN874.02

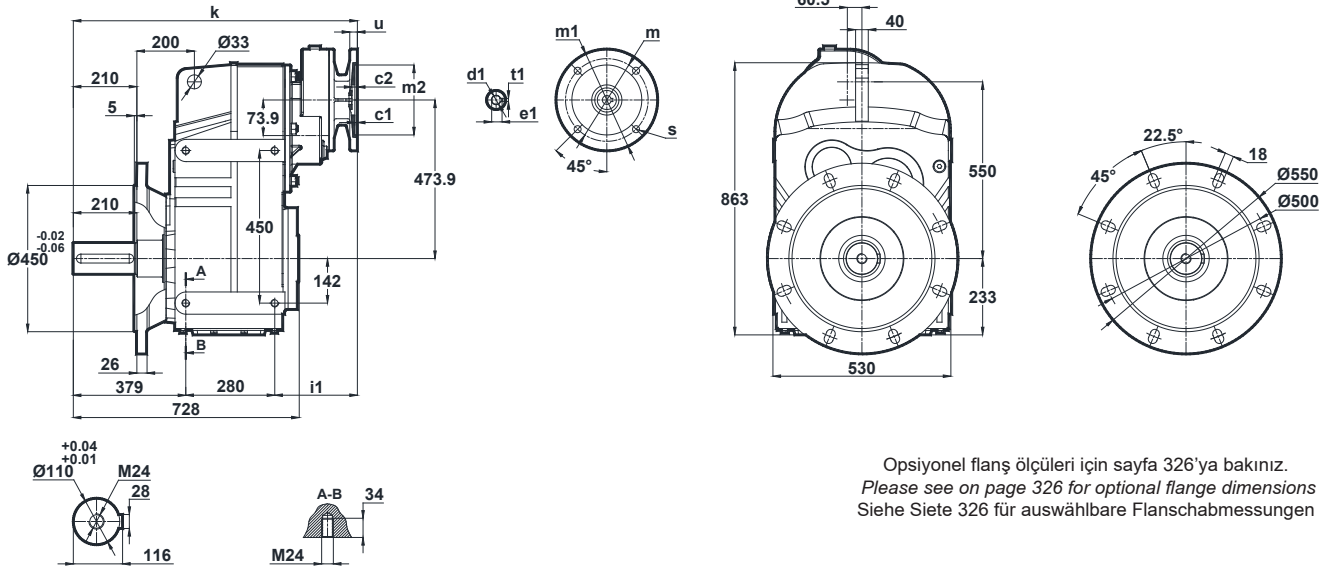

	c1	c2	s1	m	m1	m2(H7)	i1	u	k	d1	t1	e1
100/B5	5	20	15	215	250	180	215	15	875	28	8	31.3
112/B5	5	20	15	215	250	180	215	15	875	28	8	31.3
132/B5	5	9	15	265	300	230	236	15	896	38	10	41.3
132/B14	4.5		11	165	200	130						

## DN874.03

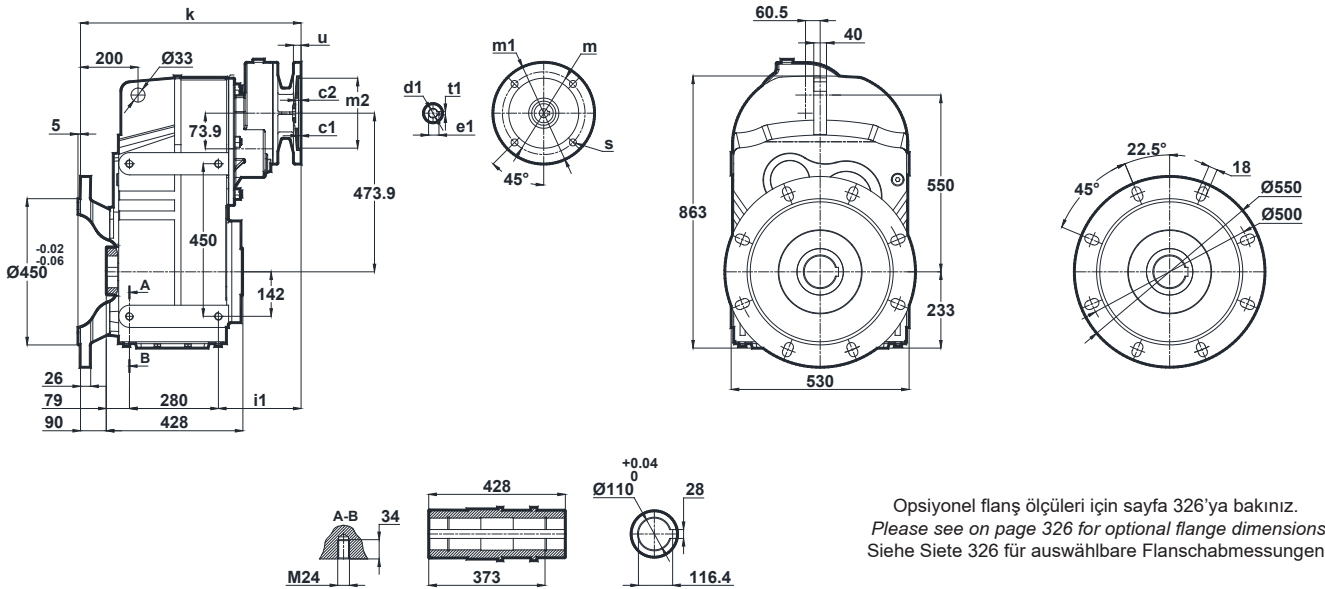

	c1	c2	s1	m	m1	m2(H7)	i1	u	k	d1	t1	e1
100/B5	5	20	15	215	250	180	215	15	665	28	8	31.3
112/B5	5	20	15	215	250	180	215	15	665	28	8	31.3
132/B5	5	9	15	265	300	230	236	15	686	38	10	41.3
132/B14	4.5		11	165	200	130						

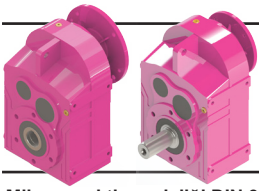

# Ölçü Sayfaları

## Dimension Pages

### Abmessungsseiten

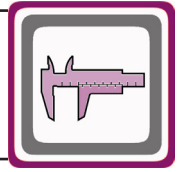

Mil ucu çekirtme deliği DIN 332 sayfa 2 / Tapped center hole according to DIN 332, sheet 2 / Zentrierung mit Gewinde nach DIN 332, Blatt 2

DN875.00  
DN876.00

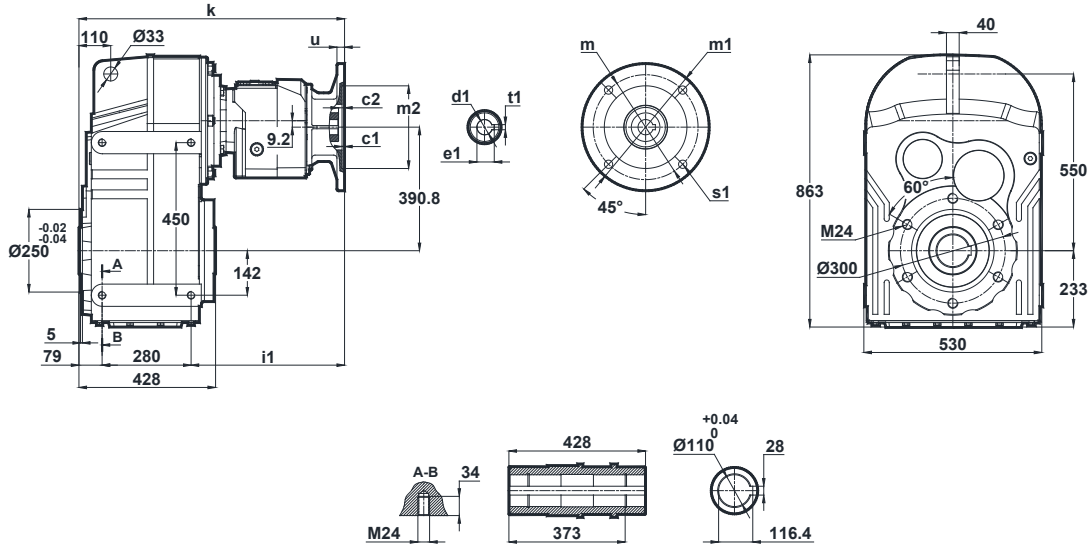

	c1	c2	s1	m	m1	m2(H7)	i1	u	k	d1	t1	e1
71/B5	4	9	11	130	160	110	333	12	693	14	5	16.3
80/B5	4	9	12	165	200	130	333	12	693	19	6	21.8
80/B14	4	9	7	100	120	80	333	12	693	19	6	21.8
90/B5	4	9	12	165	200	130	333	12	693	24	8	27.3
90/B14	4	9	9	115	140	95	333	12	693	24	8	27.3
100/B5	5	9	15	215	250	180	350	15	710	28	8	31.3
100/B14	4	9	9	130	160	110	350	15	710	28	8	31.3

DN875.01  
DN876.01

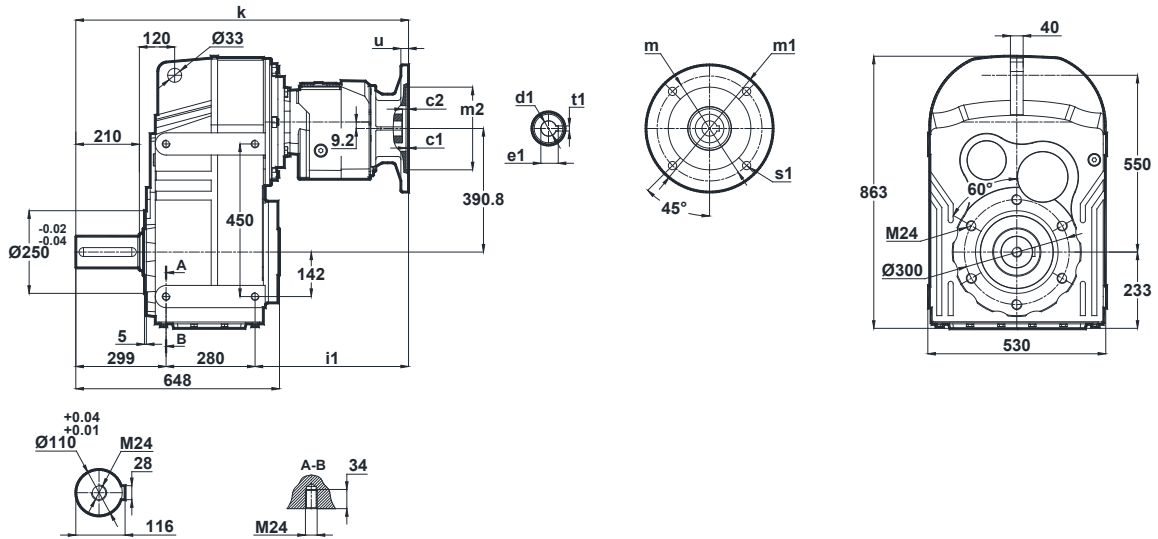

	c1	c2	s1	m	m1	m2(H7)	i1	u	k	d1	t1	e1
71/B5	4	9	11	130	160	110	333	12	913	14	5	16.3
80/B5	4	9	12	165	200	130	333	12	913	19	6	21.8
80/B14	4	9	7	100	120	80	333	12	913	19	6	21.8
90/B5	4	9	12	165	200	130	333	12	913	24	8	27.3
90/B14	4	9	9	115	140	95	333	12	913	24	8	27.3
100/B5	5	9	15	215	250	180	350	15	930	28	8	31.3
100/B14	4	9	9	130	160	110	350	15	930	28	8	31.3

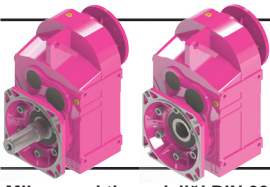

# Ölçü Sayfaları Dimension Pages Abmessungsseiten

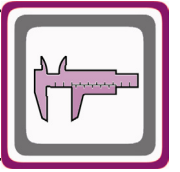

Mil ucu çektirme deliği DIN 332 sayfa 2 / Tapped center hole according to DIN 332, sheet 2 / Zentrierung mit Gewinde nach DIN 332, Blatt 2

DN875.02  
DN876.02

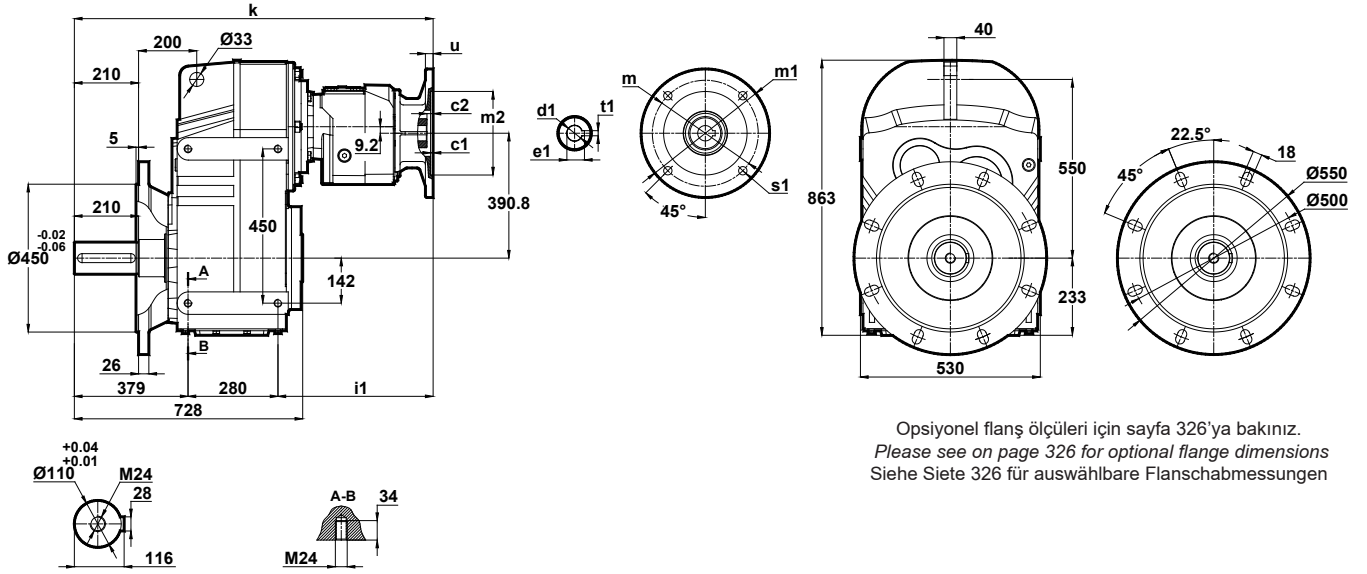

Opsiyonel flanş ölçüleri için sayfa 326'ya bakınız.  
Please see on page 326 for optional flange dimensions  
Siehe Seite 326 für auswählbare Flanschabmessungen

	c1	c2	s1	m	m1	m2(H7)	i1	u	k	d1	t1	e1
71/B5	4	9	11	130	160	110	333	12	993	14	5	16.3
80/B5	4	9	12	165	200	130	333	12	993	19	6	21.8
80/B14	4	9	7	100	120	80	333	12	993	19	6	21.8
90/B5	4	9	12	165	200	130	333	12	993	24	8	27.3
90/B14	4	9	9	115	140	95	333	12	993	24	8	27.3
100/B5	5	9	15	215	250	180	350	15	1010	28	8	31.3
100/B14	4	9	9	130	160	110	350	15	1010	28	8	31.3

DN875.03  
DN876.03

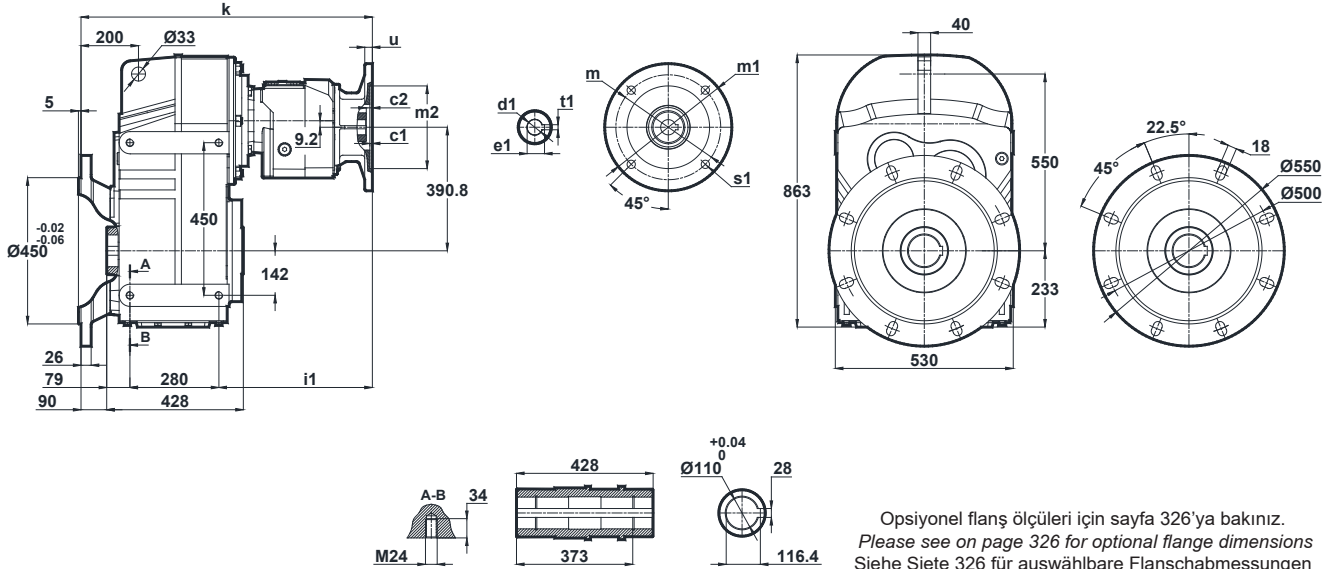

Opsiyonel flanş ölçüleri için sayfa 326'ya bakınız.  
Please see on page 326 for optional flange dimensions  
Siehe Seite 326 für auswählbare Flanschabmessungen

	c1	c2	s1	m	m1	m2(H7)	i1	u	k	d1	t1	e1
71/B5	4	9	11	130	160	110	333	12	783	14	5	16.3
80/B5	4	9	12	165	200	130	333	12	783	19	6	21.8
80/B14	4	9	7	100	120	80	333	12	783	19	6	21.8
90/B5	4	9	12	165	200	130	333	12	783	24	8	27.3
90/B14	4	9	9	115	140	95	333	12	783	24	8	27.3
100/B5	5	9	15	215	250	180	350	15	800	28	8	31.3
100/B14	4	9	9	130	160	110	350	15	800	28	8	31.3

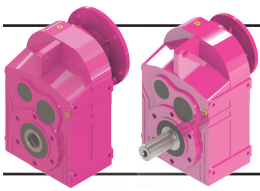

# Ölçü Sayfaları Dimension Pages Abmessungsseiten

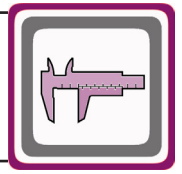

Mil ucu çekirme deliği DIN 332 sayfa 2 / Tapped center hole according to DIN 332, sheet 2 / Zentrierung mit Gewinde nach DIN 332, Blatt 2

DN972.00  
DN973.00

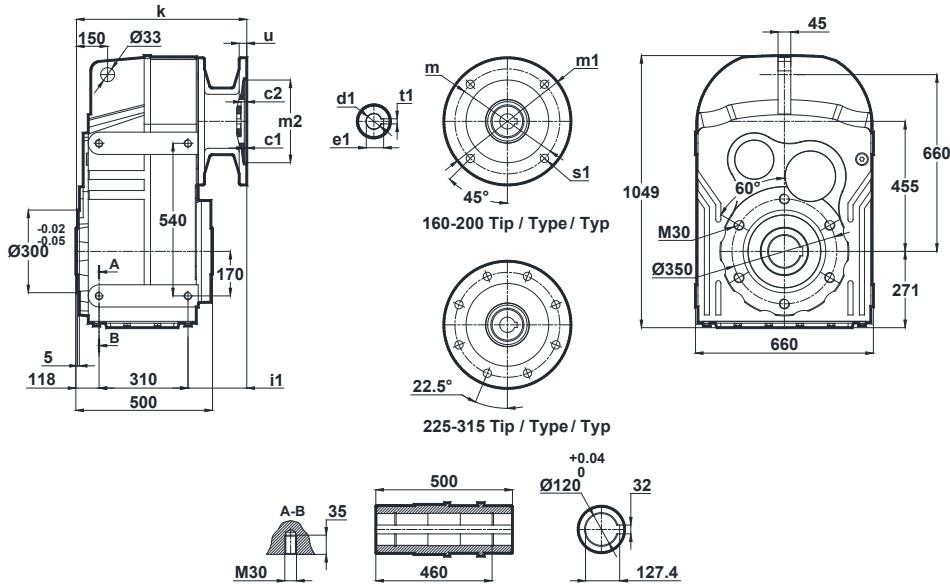

	c1	c2	s1	m	m1	m2(H7)	i1	u	k	d1	t1	e1
160/B5	5.5	10	19	300	350	250	163	20	591	42	12	45.3
180/B5	5.5	10	19	300	350	250	163	20	591	48	14	51.8
200/B5	5.5	10	19	350	400	300	187	22	615	55	16	59.3
225/B5	5.5	10	19	400	450	350	229	24	657	60	18	64.4
250/B5	5.5	10	19	500	550	450	281	24	709	65	18	69.4
280/B5	5.5	10	19	500	550	450	281	24	709	75	20	79.4
315/B5	6.5	15	24	660	600	550	331	24	759	85	22	90.4

DN972.01  
DN973.01

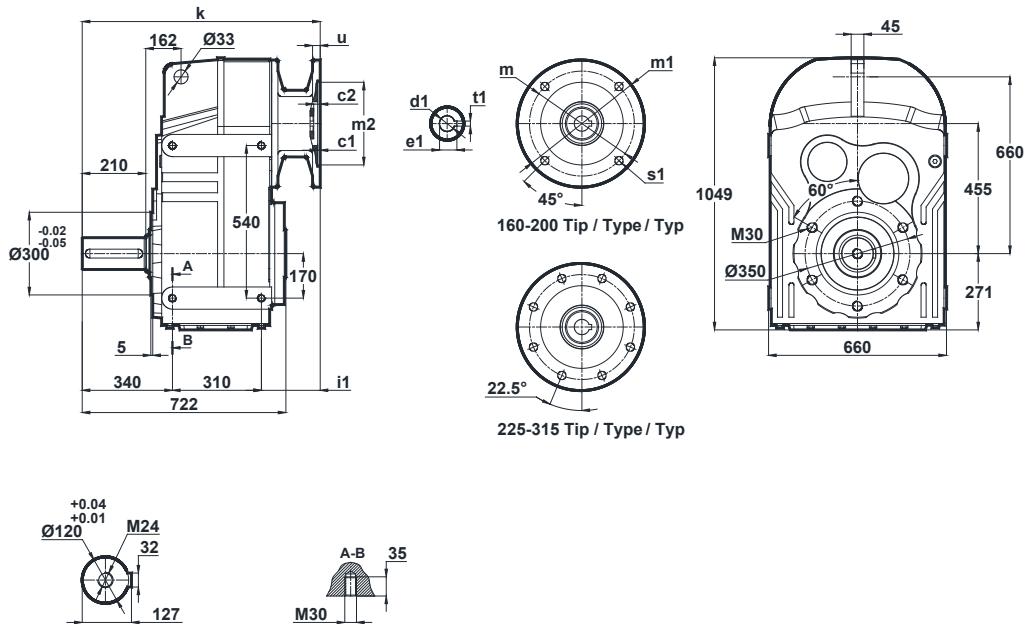

	c1	c2	s1	m	m1	m2(H7)	i1	u	k	d1	t1	e1
160/B5	5.5	10	19	300	350	250	163	20	813	42	12	45.3
180/B5	5.5	10	19	300	350	250	163	20	813	48	14	51.8
200/B5	5.5	10	19	350	400	300	187	22	837	55	16	59.3
225/B5	5.5	10	19	400	450	350	229	24	879	60	18	64.4
250/B5	5.5	10	19	500	550	450	281	24	931	65	18	69.4
280/B5	5.5	10	19	500	550	450	281	24	931	75	20	79.4
315/B5	6.5	15	24	660	600	550	331	24	981	85	22	90.4

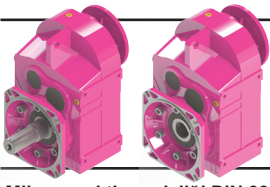

# Ölçü Sayfaları Dimension Pages Abmessungenseiten

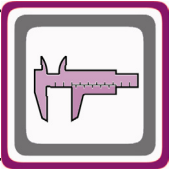

Mil ucu çektirme deliği DIN 332 sayfa 2 / Tapped center hole according to DIN 332, sheet 2 / Zentrierung mit Gewinde nach DIN 332, Blatt 2

DN972.02  
DN973.02

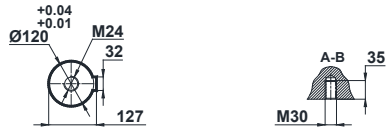
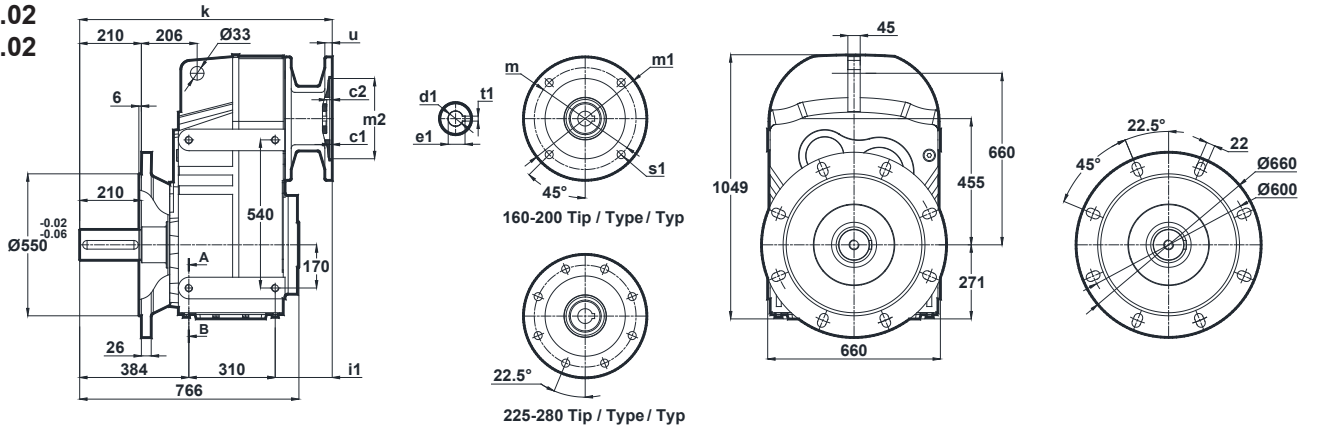

	c1	c2	s1	m	m1	m2(H7)	i1	u	k	d1	t1	e1
160/B5	5.5	10	19	300	350	250	163	20	857	42	12	45.3
180/B5	5.5	10	19	300	350	250	163	20	857	48	14	51.8
200/B5	5.5	10	19	350	400	300	187	22	881	55	16	59.3
225/B5	5.5	10	19	400	450	350	229	24	923	60	18	64.4
250/B5	5.5	10	19	500	550	450	281	24	975	65	18	69.4
280/B5	5.5	10	19	500	550	450	281	24	975	75	20	79.4
315/B5	6.5	15	24	660	600	550	331	24	1025	85	22	90.4

DN972.03  
DN973.03

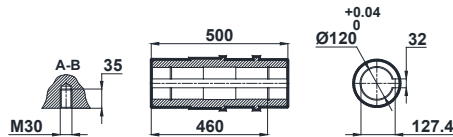
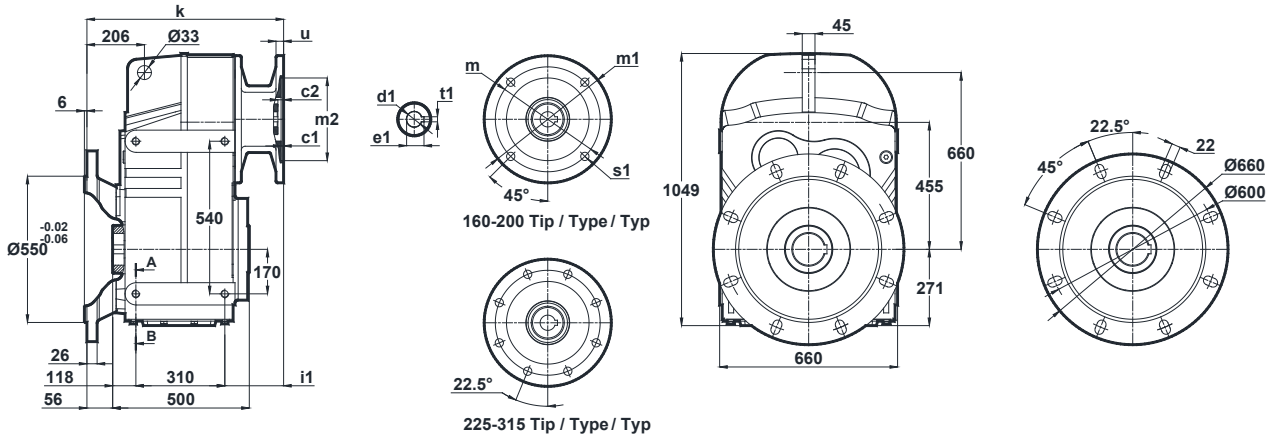

	c1	c2	s1	m	m1	m2(H7)	i1	u	k	d1	t1	e1
160/B5	5.5	10	19	300	350	250	163	20	647	42	12	45.3
180/B5	5.5	10	19	300	350	250	163	20	647	48	14	51.8
200/B5	5.5	10	19	350	400	300	187	22	671	55	16	59.3
225/B5	5.5	10	19	400	450	350	229	24	713	60	18	64.4
250/B5	5.5	10	19	500	550	450	281	24	765	65	18	69.4
280/B5	5.5	10	19	500	550	450	281	24	765	75	20	79.4
315/B5	6.5	15	24	660	600	550	331	24	815	85	22	90.4

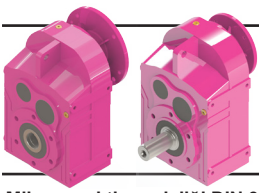

# Ölçü Sayfaları

## Dimension Pages

### Abmessungsseiten

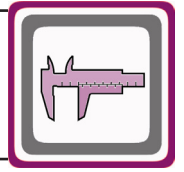

Mil ucu çekirme deliği DIN 332 sayfa 2 / Tapped center hole according to DIN 332, sheet 2 / Zentrierung mit Gewinde nach DIN 332, Blatt 2

#### DN974.00

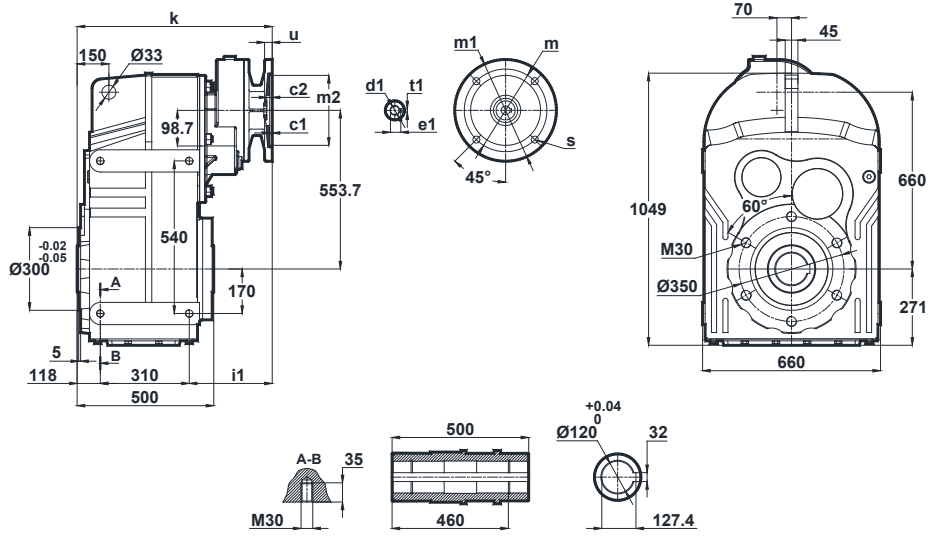

	c1	c2	s1	m	m1	m2(H7)	i1	u	k	d1	t1	e1
100/B5	5	15	15	215	250	180	252	15	571	28	8	31.3
112/B5	5	15	15	215	250	180	252	15	680	28	8	31.3
132/B5 132/B14	4.5	9	15	265 165	300 200	230 130	267	15	695	38	10	41.3

#### DN974.01

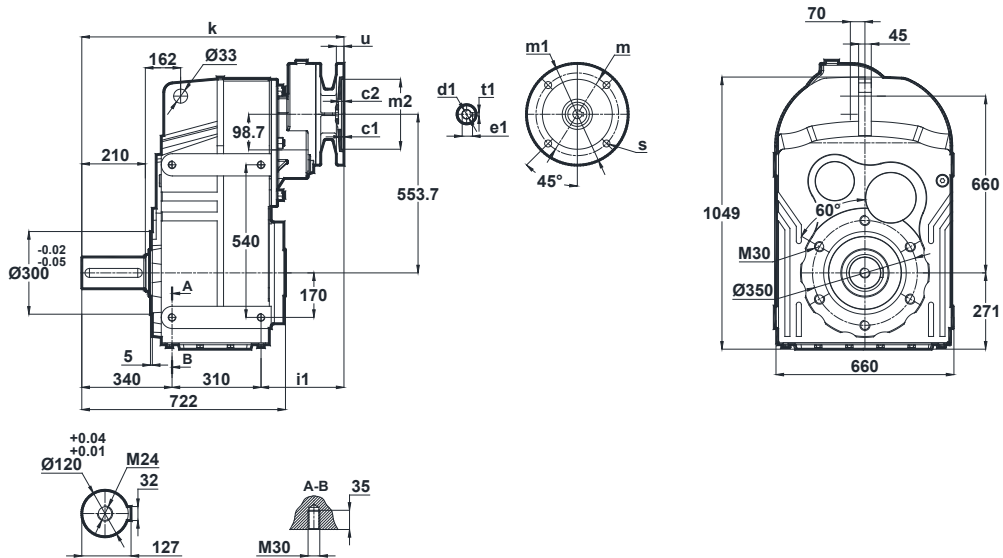

	c1	c2	s1	m	m1	m2(H7)	i1	u	k	d1	t1	e1
100/B5	5	15	15	215	250	180	252	15	791	28	8	31.3
112/B5	5	15	15	215	250	180	252	15	902	28	8	31.3
132/B5 132/B14	4.5	9	15	265 165	300 200	230 130	267	15	917	38	10	41.3

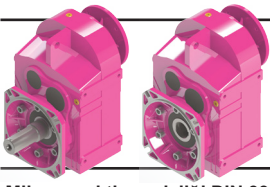

# Ölçü Sayfaları Dimension Pages Abmessungenseiten

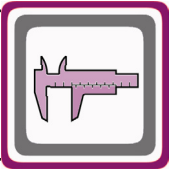

Mil ucu çektirme deliği DIN 332 sayfa 2 / Tapped center hole according to DIN 332, sheet 2 / Zentrierung mit Gewinde nach DIN 332, Blatt 2

## DN974.02

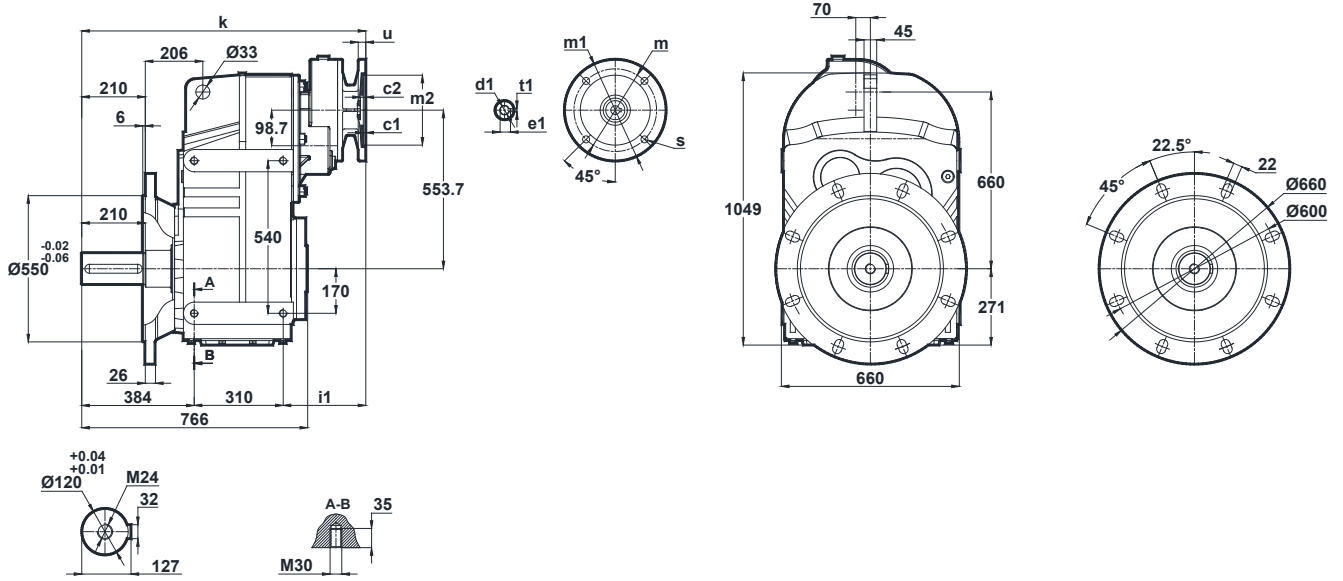

	c1	c2	s1	m	m1	m2(H7)	i1	u	k	d1	t1	e1
100/B5	5	15	15	215	250	180	252	15	871	28	8	31.3
112/B5	5	15	15	215	250	180	252	15	946	28	8	31.3
132/B5 132/B14	4.5	9	15	265 165	300 200	230 130	267	15	961	38	10	41.3

## DN974.03

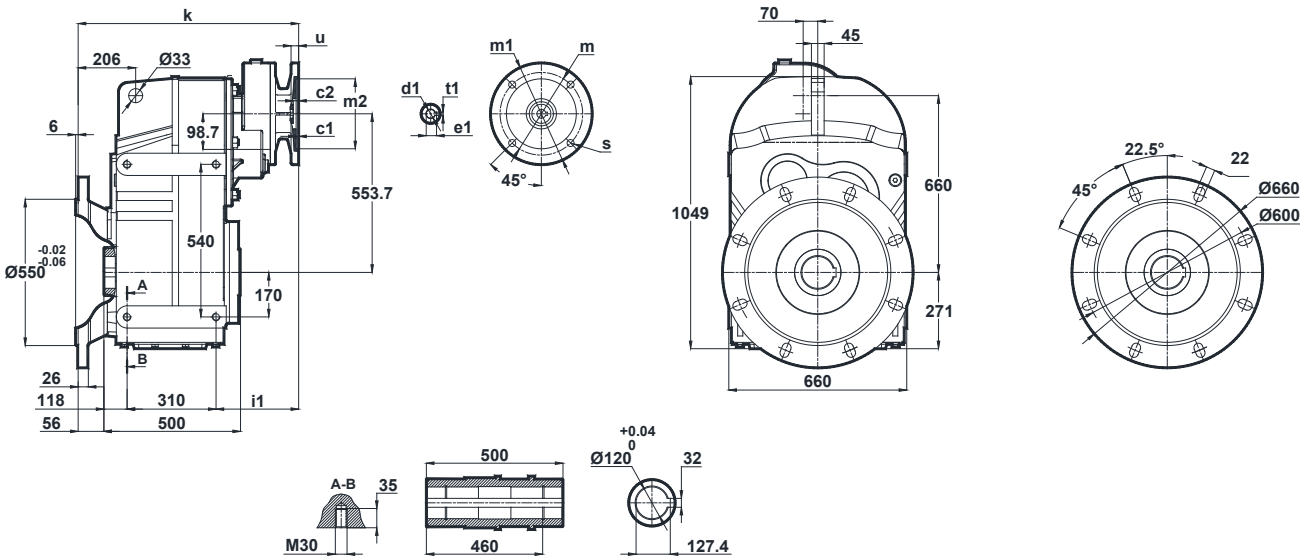

	c1	c2	s1	m	m1	m2(H7)	i1	u	k	d1	t1	e1
100/B5	5	15	15	215	250	180	252	15	661	28	8	31.3
112/B5	5	15	15	215	250	180	252	15	736	28	8	31.3
132/B5 132/B14	4.5	9	15	265 165	300 200	230 130	267	15	751	38	10	41.3

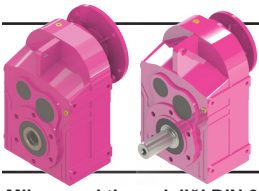

# Ölçü Sayfaları

## Dimension Pages

### Abmessungsseiten

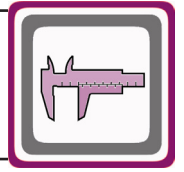

Mil ucu çekirtme deliği DIN 332 sayfa 2 / Tapped center hole according to DIN 332, sheet 2 / Zentrierung mit Gewinde nach DIN 332, Blatt 2

DN975.00  
DN976.00

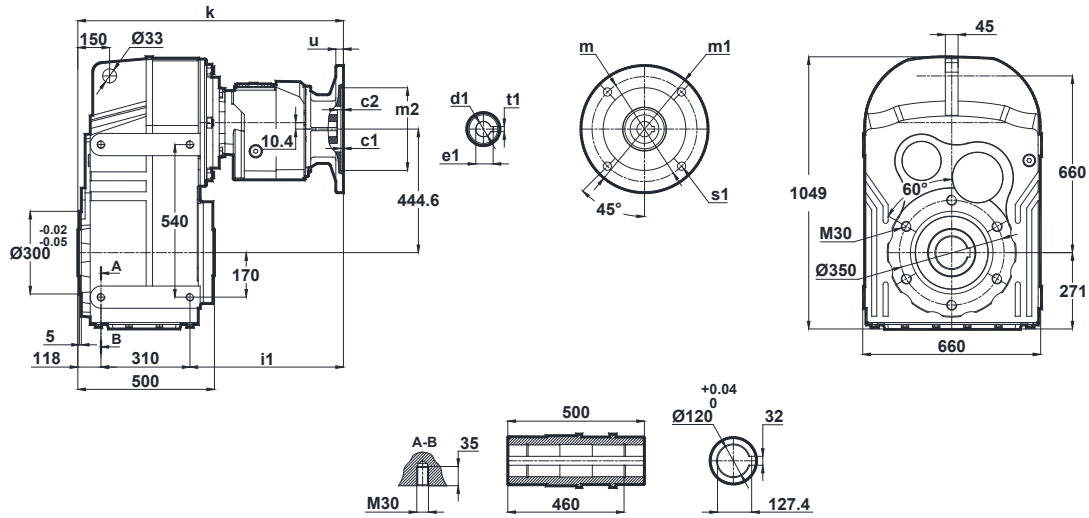

	c1	c2	s1	m	m1	m2(H7)	i1	u	k	d1	t1	e1
80/B5	4	5	12	165	200	130	388	12	816	19	6	21.8
90/B5 90/B14	4	5	12 9	165 115	200 140	130 95	388	12	816	24	8	27.3
100/B5 100/B14	5 4	9	15 9	215 130	250 160	180 110	406	15	834	28	8	31.3

DN975.01  
DN976.01

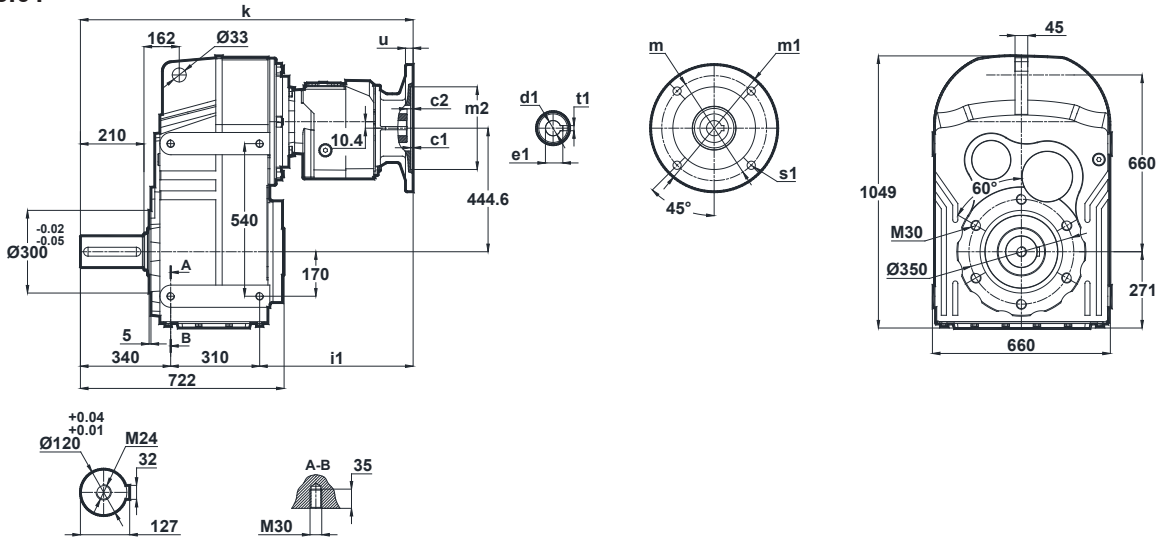

	c1	c2	s1	m	m1	m2(H7)	i1	u	k	d1	t1	e1
80/B5	4	5	12	165	200	130	388	12	1038	19	6	21.8
90/B5 90/B14	4	5	12 9	165 115	200 140	130 95	388	12	1038	24	8	27.3
100/B5 100/B14	5 4	9	15 9	215 130	250 160	180 110	406	15	1056	28	8	31.3

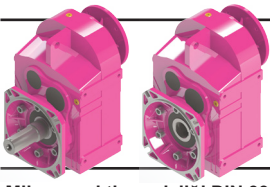

# Ölçü Sayfaları Dimension Pages Abmessungenseiten

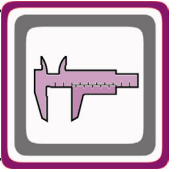

Mil ucu çektirme deliği DIN 332 sayfa 2 / Tapped center hole according to DIN 332, sheet 2 / Zentrierung mit Gewinde nach DIN 332, Blatt 2

DN975.02  
DN976.02

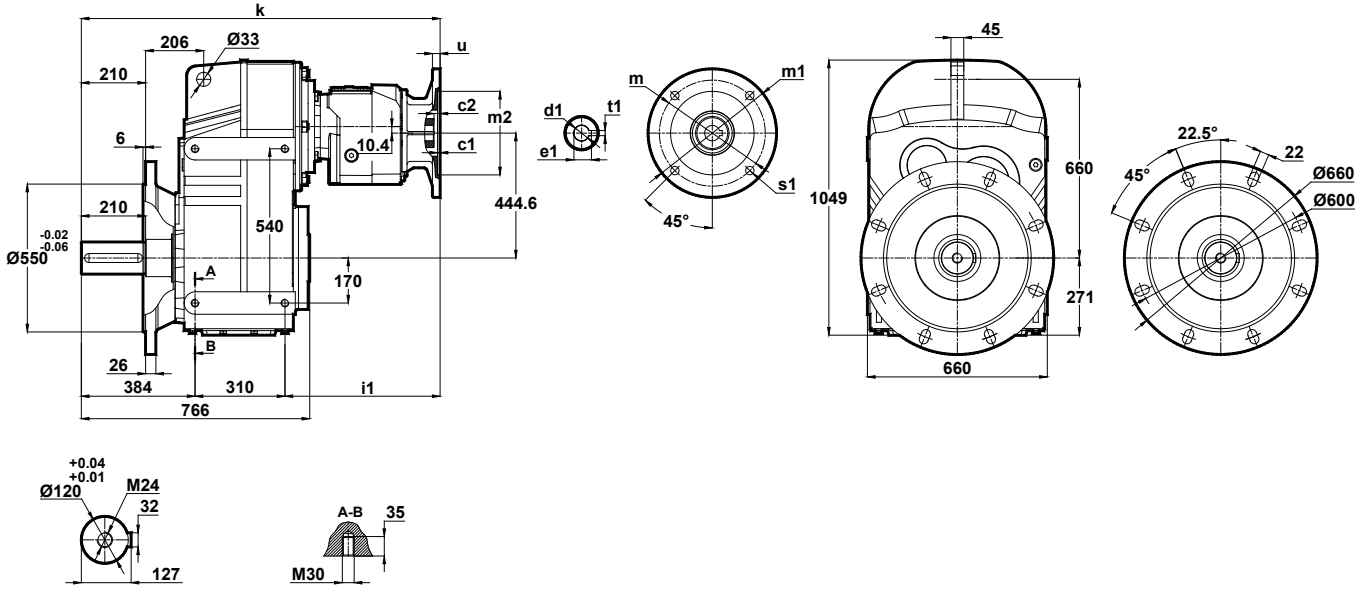

	c1	c2	s1	m	m1	m2(H7)	i1	u	k	d1	t1	e1
80/B5	4	5	12	165	200	130	388	12	1082	19	6	21.8
90/B5 90/B14	4	5	12 9	165 115	200 140	130 95	388	12	1082	24	8	27.3
100/B5 100/B14	5 4	9	15 9	215 130	250 160	180 110	406	15	1100	28	8	31.3

DN975.03  
DN976.03

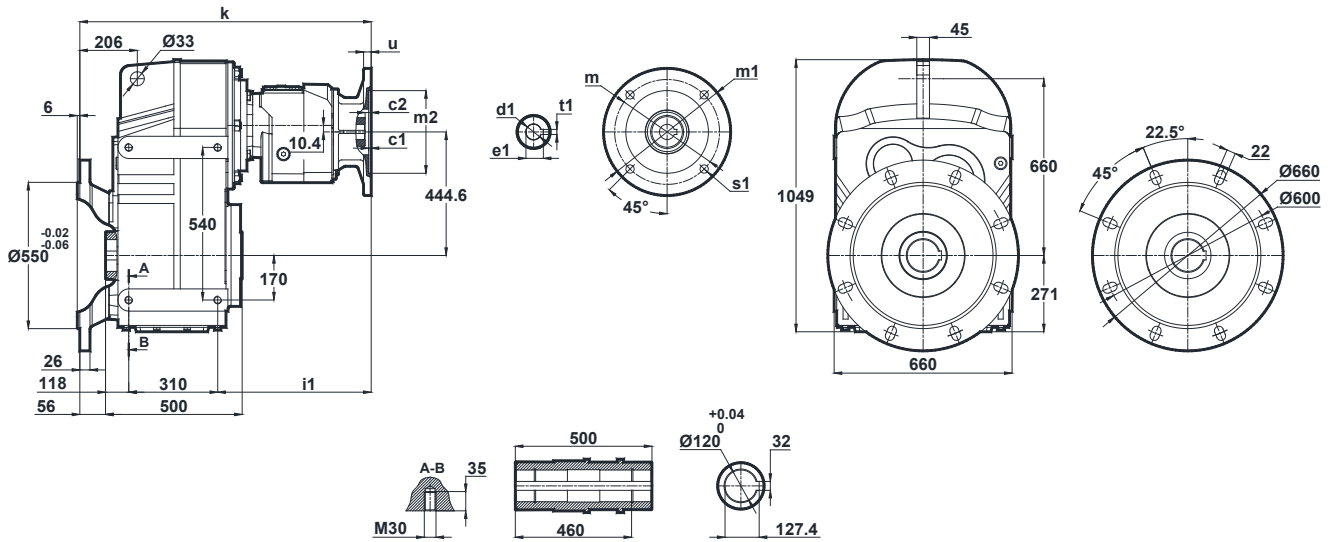

	c1	c2	s1	m	m1	m2(H7)	i1	u	k	d1	t1	e1
80/B5	4	5	12	165	200	130	388	12	872	19	6	21.8
90/B5 90/B14	4	5	12 9	165 115	200 140	130 95	388	12	872	24	8	27.3
100/B5 100/B14	5 4	9	15 9	215 130	250 160	180 110	406	15	890	28	8	31.3

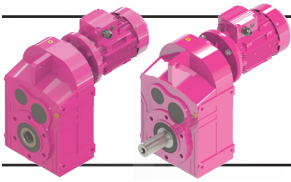

# Ölçü Sayfaları

## Dimension Pages

### Abmessungsseiten

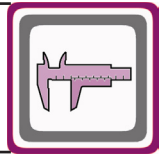

Mil ucu çektirme deliği DIN 332 sayfa 2 / Tapped center hole according to DIN 332, sheet 2 / Zentrierung mit Gewinde nach DIN 332, Blatt 2

DV072.00  
DV073.00

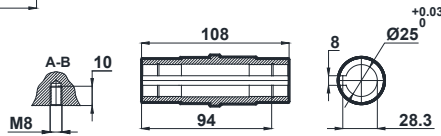
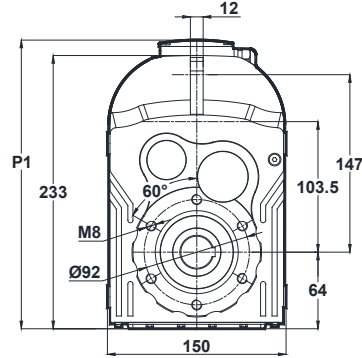
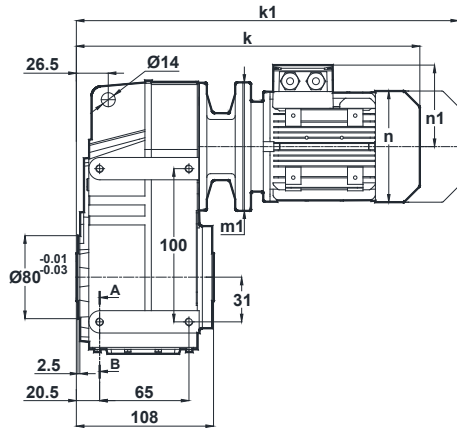

Klemens Pozisyonları  
Terminal Box Positions  
Klemmenkasten Positionen

	63/B5 63/B14	71/B5 71/B14	80/B5 80/B14	90S/B5 90S/B14	90L/B5 90L/B14	100L/B5 100L/B14
k	338	357.5	395.5	436.5	436.5	483
k1	399	448.5	488.5	540	540	591.5
n / n1	121 / 97	137 / 112	155 / 121	176 / 132	176 / 132	193 / 147
m1 (B5)	140	160	200	200	200	250
m1 (B14)	90	105	120	140	140	160
p1	264.5	279.5	288.5	299.5	299.5	314.5

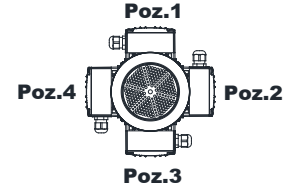

63-71-80-90-100  
Tip / Type / Typ

DV072.01  
DV073.01

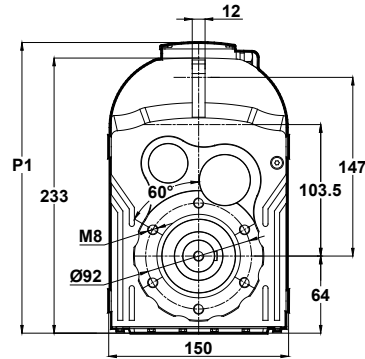
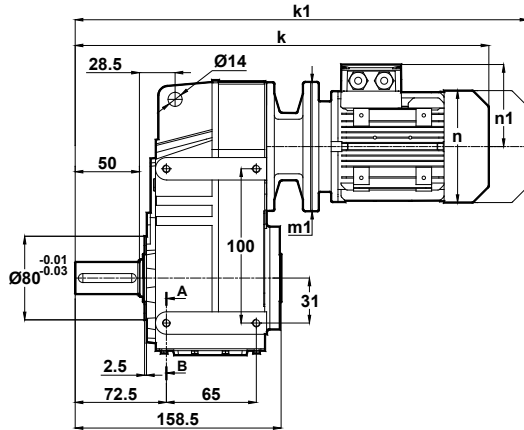

Klemens Pozisyonları  
Terminal Box Positions  
Klemmenkasten Positionen

	63/B5 63/B14	71/B5 71/B14	80/B5 80/B14	90S/B5 90S/B14	90L/B5 90L/B14	100L/B5 100L/B14
k	390	409.5	447.5	488.5	488.5	535
k1	451	500.5	540.5	592	592	643.5
n / n1	121 / 97	137 / 112	155 / 121	176 / 132	176 / 132	193 / 147
m1 (B5)	140	160	200	200	200	250
m1 (B14)	90	105	120	140	140	160
p1	264.5	279.5	288.5	299.5	299.5	314.5

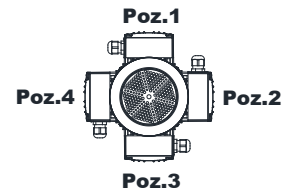

63-71-80-90-100  
Tip / Type / Typ

"k1" ölçüsü frenli redüktörlere aittir.  
Dimensions "k1" is for motors with brake.  
Maße "k1" ist für Bremsenmotoren.

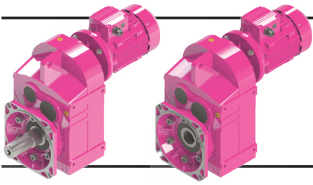

# Ölçü Sayfaları

## Dimension Pages

### Abmessungsseiten

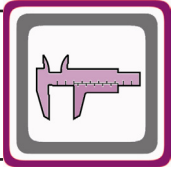

Mil ucu çektirme deliği DIN 332 sayfa 2 / Tapped center hole according to DIN 332, sheet 2 / Zentrierung mit Gewinde nach DIN 332, Blatt 2

DV072.02  
DV073.02

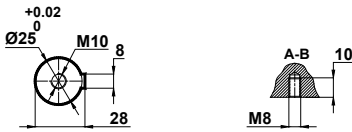
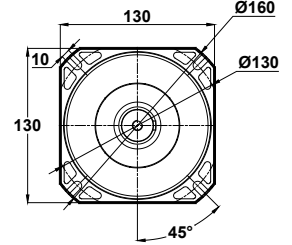
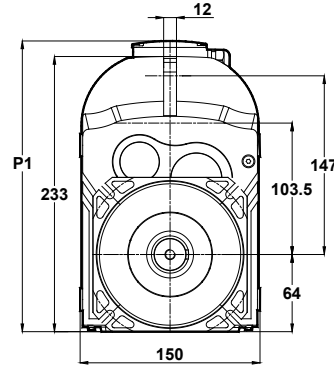
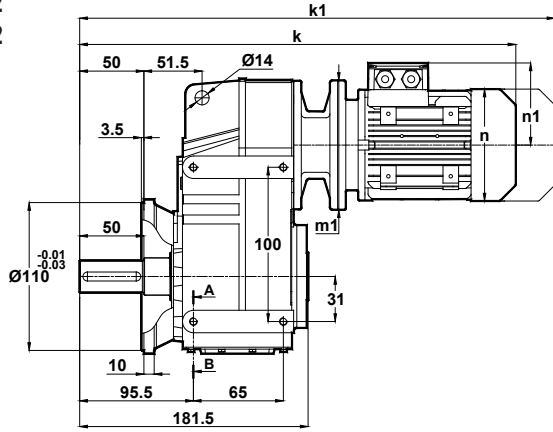

Klemens Pozisyonları  
Terminal Box Positions  
Klemmenkasten Positionen

Opsiyonel Flanş Ölçüleri  
Optional Flange Dimensions  
Auswählbare Flanschabmessungen

	63/B5 63/B14	71/B5 71/B14	80/B5 80/B14	90S/B5 90S/B14	90L/B5 90L/B14	100L/B5 100L/B14
k	413	432.5	470.5	511.5	511.5	558
k1	474	523.5	563.5	615	615	666.5
n / n1	121 / 97	137 / 112	155 / 121	176 / 132	176 / 132	193 / 147
m1 (B5)	140	160	200	200	200	250
m1 (B14)	90	105	120	140	140	160
p1	264.5	279.5	288.5	299.5	299.5	314.5

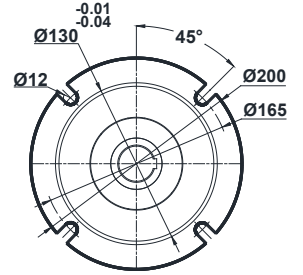
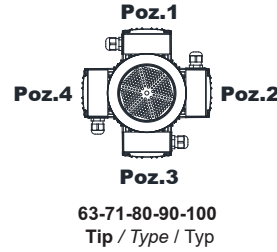

DV072.03  
DV073.03

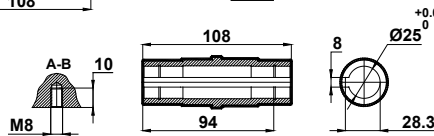
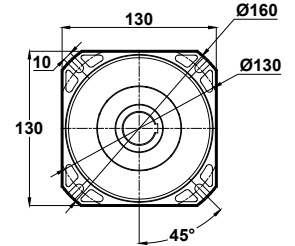
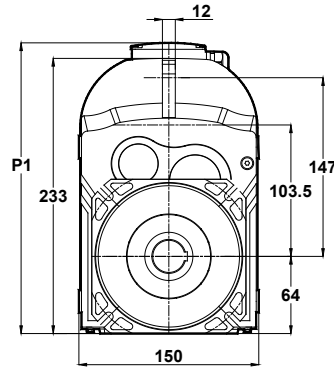
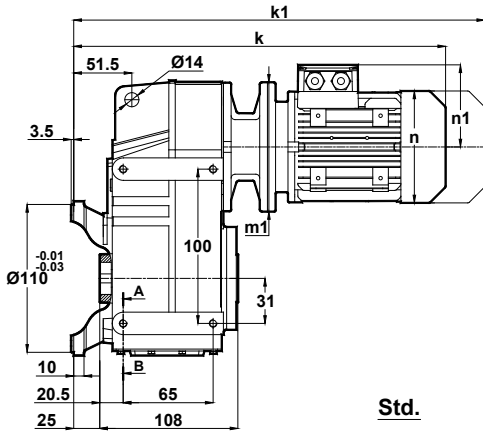

Klemens Pozisyonları  
Terminal Box Positions  
Klemmenkasten Positionen

Opsiyonel Flanş Ölçüleri  
Optional Flange Dimensions  
Auswählbare Flanschabmessungen

	63/B5 63/B14	71/B5 71/B14	80/B5 80/B14	90S/B5 90S/B14	90L/B5 90L/B14	100L/B5 100L/B14
k	363	382.5	420.5	461.5	461.5	508
k1	424	473.5	513.5	565	565	616.5
n / n1	121 / 97	137 / 112	155 / 121	176 / 132	176 / 132	193 / 147
m1 (B5)	140	160	200	200	200	250
m1 (B14)	90	105	120	140	140	160
p1	264.5	279.5	288.5	299.5	299.5	314.5

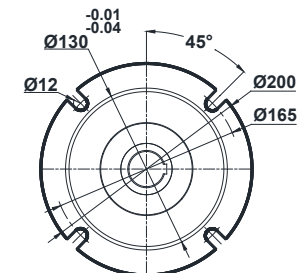
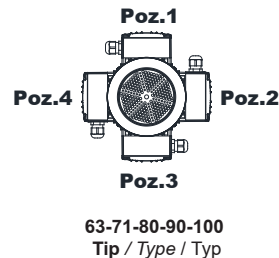

"k1" ölçüsü frenli redüktörlere aittir.  
Dimensions "k1" is for motors with brake.  
Maße "k1" ist für Bremsenmotoren.

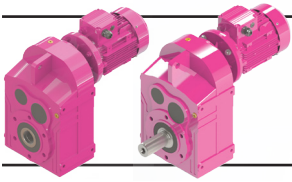

# Ölçü Sayfaları

## Dimension Pages

### Abmessungsseiten

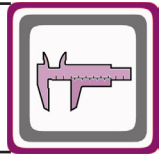

Mil ucu çekirtme deliği DIN 332 sayfa 2 / Tapped center hole according to DIN 332, sheet 2 / Zentrierung mit Gewinde nach DIN 332, Blatt 2

DV172.00  
DV173.00

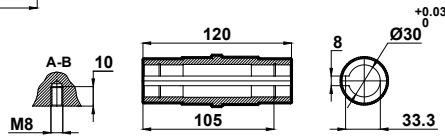
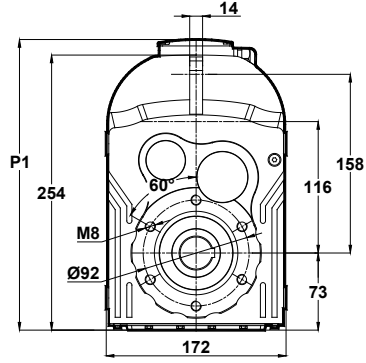
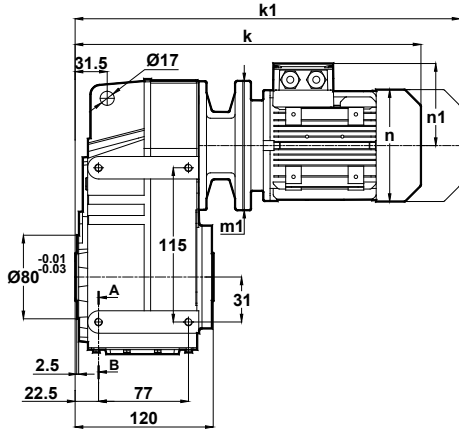

Klemens Pozisyonları  
Terminal Box Positions  
Klemmenkasten Positionen

	63/B5 63/B14	71/B5 71/B14	80/B5 80/B14	90S/B5 90S/B14	90L/B5 90L/B14	100L/B5 100L/B14
k	347	367	405	446	446	492
k1	408	458	498	550.5	550.5	611.5
n / n1	121 / 97	137 / 112	155 / 121	176 / 132	176 / 132	193 / 147
m1 (B5)	140	160	200	200	200	250
m1 (B14)	90	105	120	140	140	160
p1	286	301	310	321	321	336

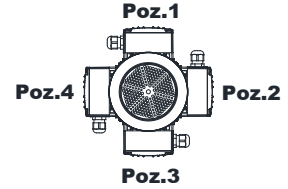

63-71-80-90-100  
Tip / Type / Typ

DV172.01  
DV173.01

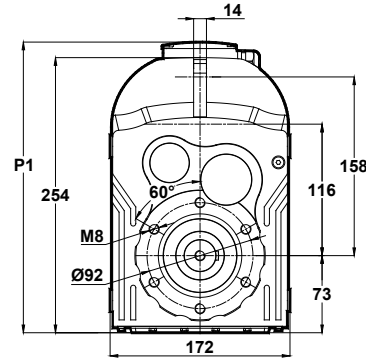
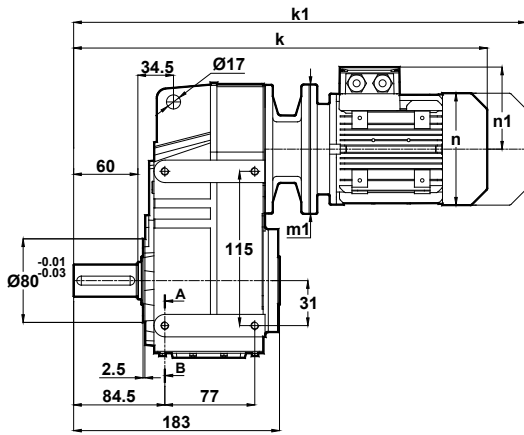

Klemens Pozisyonları  
Terminal Box Positions  
Klemmenkasten Positionen

	63/B5 63/B14	71/B5 71/B14	80/B5 80/B14	90S/B5 90S/B14	90L/B5 90L/B14	100L/B5 100L/B14
k	410	430	468	509	509	555
k1	471	521	561	613.5	613.5	674.5
n / n1	121 / 97	137 / 112	155 / 121	176 / 132	176 / 132	193 / 147
m1 (B5)	140	160	200	200	200	250
m1 (B14)	90	105	120	140	140	160
p1	286	301	310	321	321	336

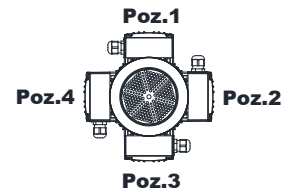

63-71-80-90-100  
Tip / Type / Typ

"k1" ölçüsü frenli redüktörlere aittir.  
Dimensions "k1" is for motors with brake.  
Maße "k1" ist für Bremsenmotoren.

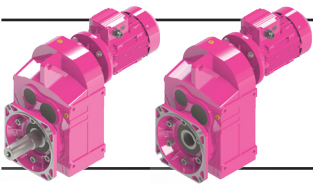

# Ölçü Sayfaları

## Dimension Pages

### Abmessungsseiten

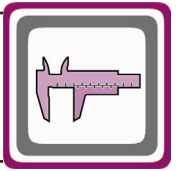

Mil ucu çektirme deliği DIN 332 sayfa 2 / Tapped center hole according to DIN 332, sheet 2 / Zentrierung mit Gewinde nach DIN 332, Blatt 2

DV172.02  
DV173.02

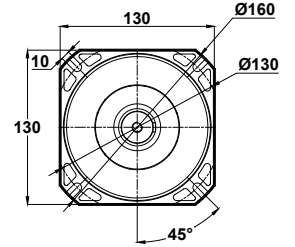
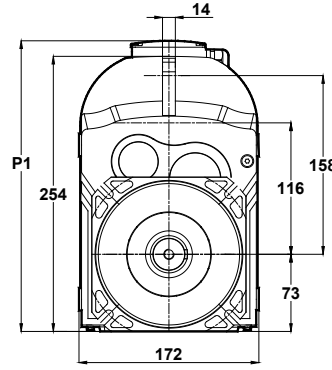
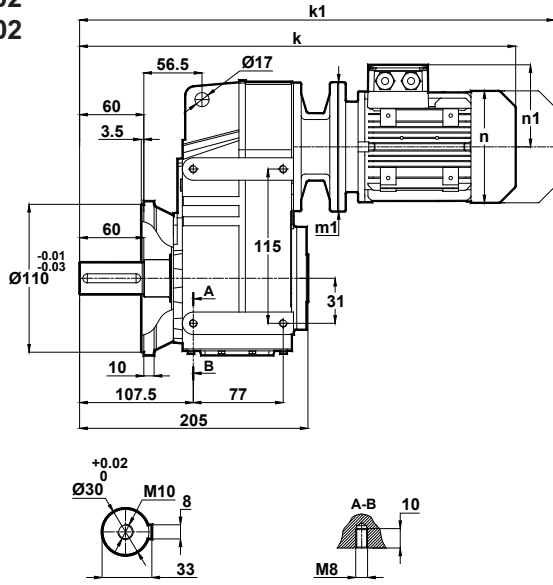

Klemens Pozisyonları  
Terminal Box Positions  
Klemmenkasten Positionen

Opsiyonel Flanş Ölçüleri  
Optional Flange Dimensions  
Auswählbare Flanschabmessungen

	63/B5 63/B14	71/B5 71/B14	80/B5 80/B14	90S/B5 90S/B14	90L/B5 90L/B14	100L/B5 100L/B14
k	432	452	490	531	531	577
k1	493	543	583	635.5	635.5	696.5
n / n1	121 / 97	137 / 112	155 / 121	176 / 132	176 / 132	193 / 147
m1 (B5)	140	160	200	200	200	250
m1 (B14)	90	105	120	140	140	160
p1	286	301	310	321	321	336

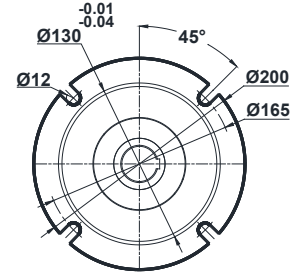
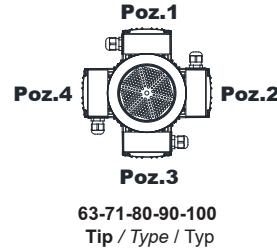

DV172.03  
DV173.03

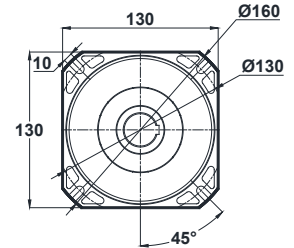
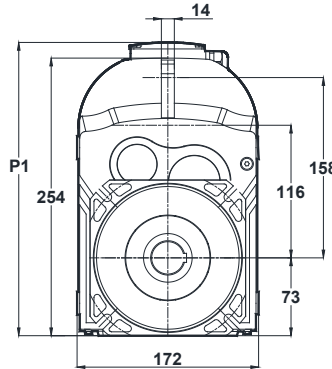
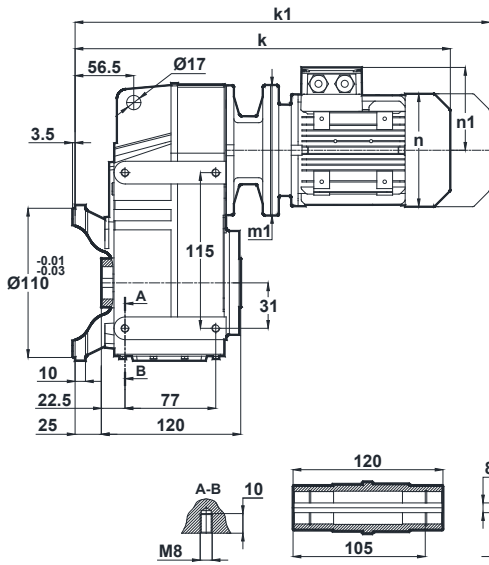

Klemens Pozisyonları  
Terminal Box Positions  
Klemmenkasten Positionen

Opsiyonel Flanş Ölçüleri  
Optional Flange Dimensions  
Auswählbare Flanschabmessungen

	63/B5 63/B14	71/B5 71/B14	80/B5 80/B14	90S/B5 90S/B14	90L/B5 90L/B14	100L/B5 100L/B14
k	372	392	430	471	471	517
k1	433	483	523	575.5	575.5	636.5
n / n1	121 / 97	137 / 112	155 / 121	176 / 132	176 / 132	193 / 147
m1 (B5)	140	160	200	200	200	250
m1 (B14)	90	105	120	140	140	160
p1	286	301	310	321	321	336

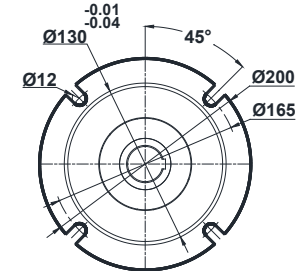
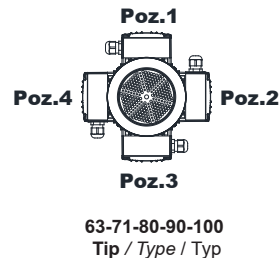

"k1" ölçüsü frenli redüktörlere aittir.  
Dimensions "k1" is for motors with brake.  
Maße "k1" ist für Bremsenmotoren.

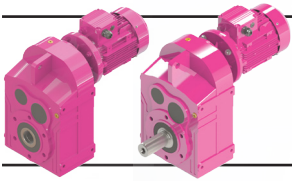

# Ölçü Sayfaları

## Dimension Pages

### Abmessungsseiten

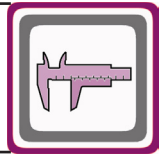

Mil ucu çektirme deliği DIN 332 sayfa 2 / Tapped center hole according to DIN 332, sheet 2 / Zentrierung mit Gewinde nach DIN 332, Blatt 2

DV272.00  
DV273.00

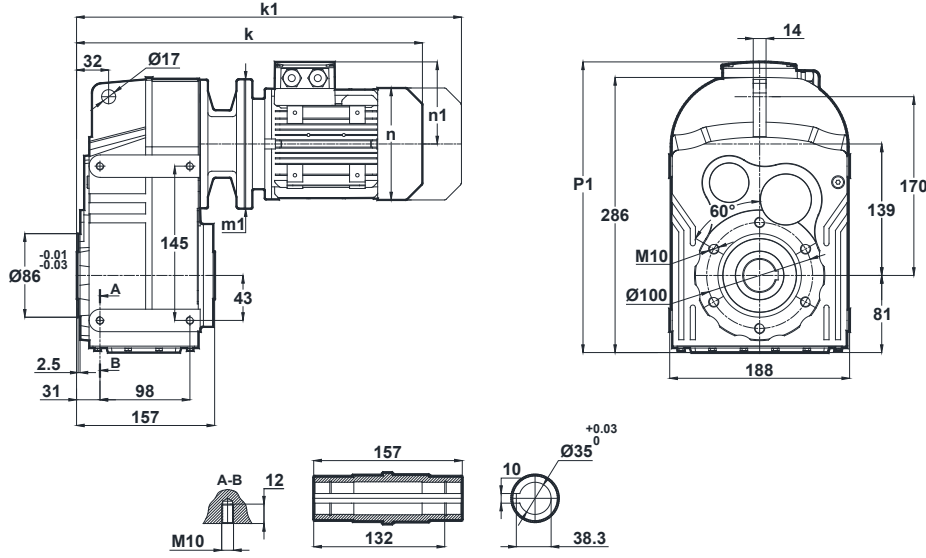

Klemens Pozisyonları  
Terminal Box Positions  
Klemmenkasten Positionen

	63/B5 63/B14	71/B5 71/B14	80/B5 80/B14	90S/B5 90S/B14	90L/B5 90L/B14	100L/B5 100L/B14
k	377	397	435	476	476	522
k1	438	488	528	580.5	580.5	641.5
n / n1	121 / 97	137 / 112	155 / 121	176 / 132	176 / 132	193 / 147
m1 (B5)	140	160	200	200	200	250
m1 (B14)	90	105	120	140	140	160
p1	317	332	341	352	352	367

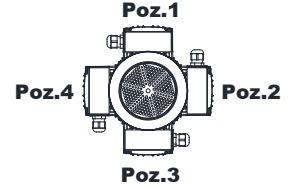

63-71-80-90-100  
Tip / Type / Typ

DV272.01  
DV273.01

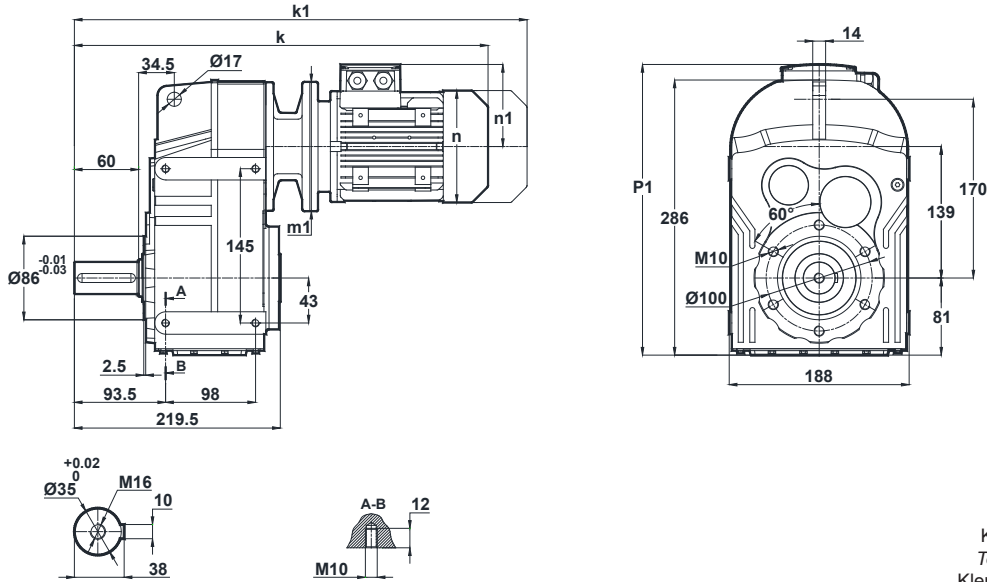

Klemens Pozisyonları  
Terminal Box Positions  
Klemmenkasten Positionen

	63/B5 63/B14	71/B5 71/B14	80/B5 80/B14	90S/B5 90S/B14	90L/B5 90L/B14	100L/B5 100L/B14
k	439	459	497	538	538	584
k1	500	550	590	642.5	642.5	703.5
n / n1	121 / 97	137 / 112	155 / 121	176 / 132	176 / 132	193 / 147
m1 (B5)	140	160	200	200	200	250
m1 (B14)	90	105	120	140	140	160
p1	317	332	341	352	352	367

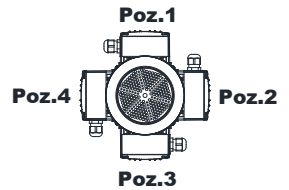

63-71-80-90-100  
Tip / Type / Typ

"k1" ölçüsü frenli redüktörlere aittir.  
Dimensions "k1" is for motors with brake.  
Maße "k1" ist für Bremsenmotoren.

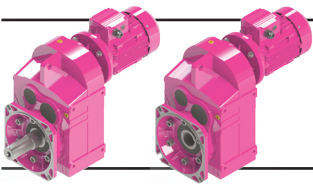

# Ölçü Sayfaları Dimension Pages Abmessungsseiten

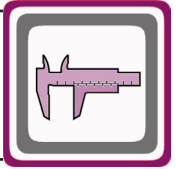

Mil ucu çektirme deliği DIN 332 sayfa 2 / Tapped center hole according to DIN 332, sheet 2 / Zentrierung mit Gewinde nach DIN 332, Blatt 2

DV272.02  
DV273.02

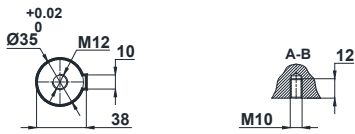
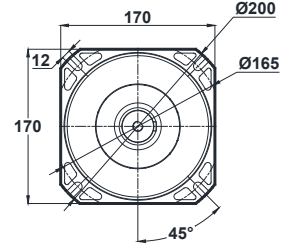
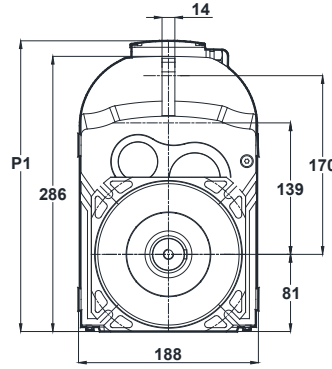
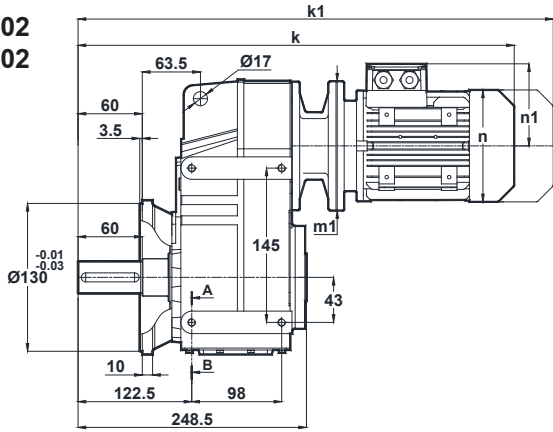

	63/B5 63/B14	71/B5 71/B14	80/B5 80/B14	90S/B5 90S/B14	90L/B5 90L/B14	100L/B5 100L/B14
k	468	487.5	526	567	567	613
k1	529	578.5	619	671.5	671.5	732.5
n / n1	121 / 97	137 / 112	155 / 121	176 / 132	176 / 132	193 / 147
m1 (B5)	140	160	200	200	200	250
m1 (B14)	90	105	120	140	140	160
p1	317	332	341	352	352	367

Klemens Pozisyonları  
Terminal Box Positions  
Klemmenkasten Positionen

Opsiyonel Flanş Ölçüleri  
Optional Flange Dimensions  
Auswählbare Flanschabmessungen

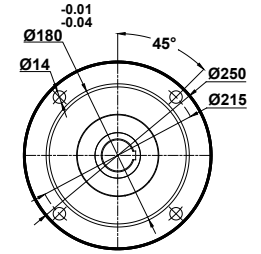
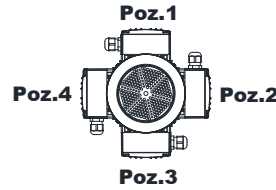

63-71-80-90-100  
Tip / Type / Typ

DV272.03  
DV273.03

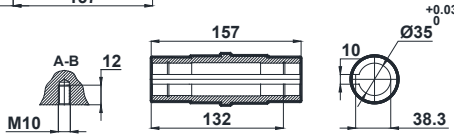
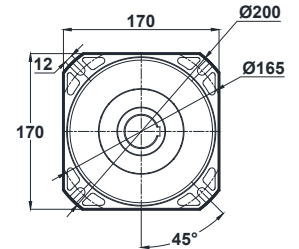
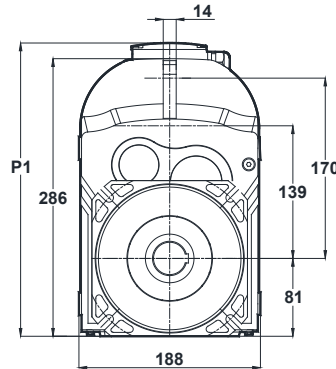
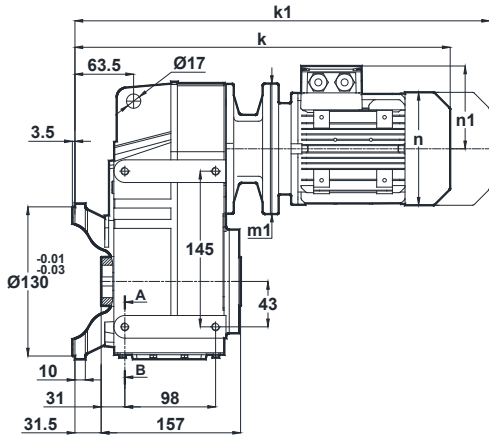

	63/B5 63/B14	71/B5 71/B14	80/B5 80/B14	90S/B5 90S/B14	90L/B5 90L/B14	100L/B5 100L/B14
k	408	428	466	507	507	553
k1	469	519	559	611.5	611.5	672.5
n / n1	121 / 97	137 / 112	155 / 121	176 / 132	176 / 132	193 / 147
m1 (B5)	140	160	200	200	200	250
m1 (B14)	90	105	120	140	140	160
p1	317	332	341	352	352	367

Klemens Pozisyonları  
Terminal Box Positions  
Klemmenkasten Positionen

Opsiyonel Flanş Ölçüleri  
Optional Flange Dimensions  
Auswählbare Flanschabmessungen

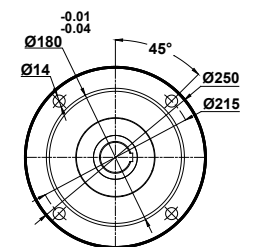
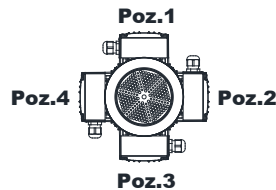

63-71-80-90-100  
Tip / Type / Typ

"k1" ölçüsü frenli redüktörlere aittir.  
Dimensions "k1" is for motors with brake.  
Maße "k1" ist für Bremsenmotoren.

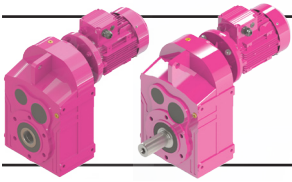

# Ölçü Sayfaları

## Dimension Pages

### Abmessungsseiten

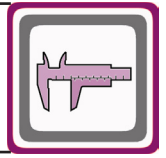

Mil ucu çektirme deliği DIN 332 sayfa 2 / Tapped center hole according to DIN 332, sheet 2 / Zentrierung mit Gewinde nach DIN 332, Blatt 2

DV275.00  
DV276.00

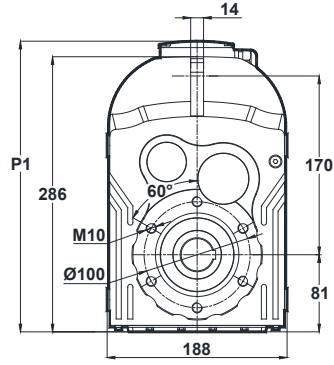
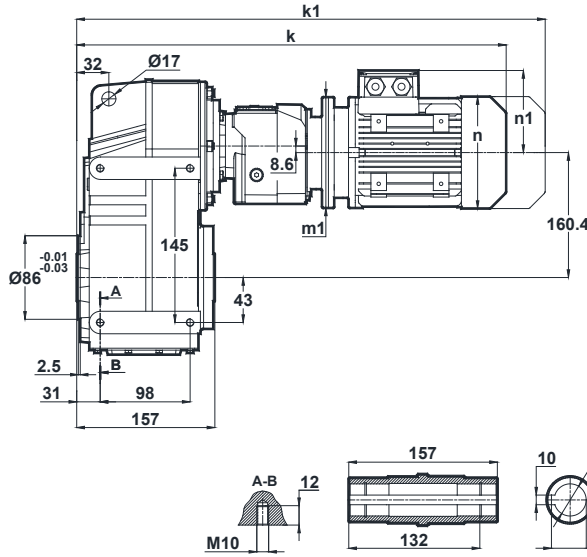

Klemens Pozisyonları  
Terminal Box Positions  
Klemmenkasten Positionen

	63/B5 63/B14	71/B5 71/B14
k	526	546
k1	587	637
n / n1	121 / 97	137 / 112
m1 (B5)	140	160
m1 (B14)	90	105
p1	309	324

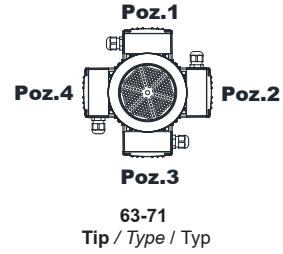

DV275.01  
DV276.01

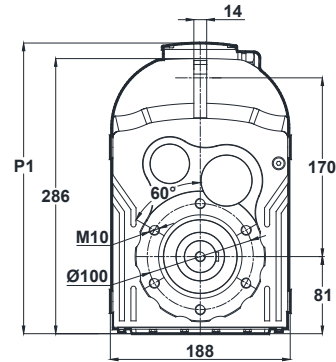
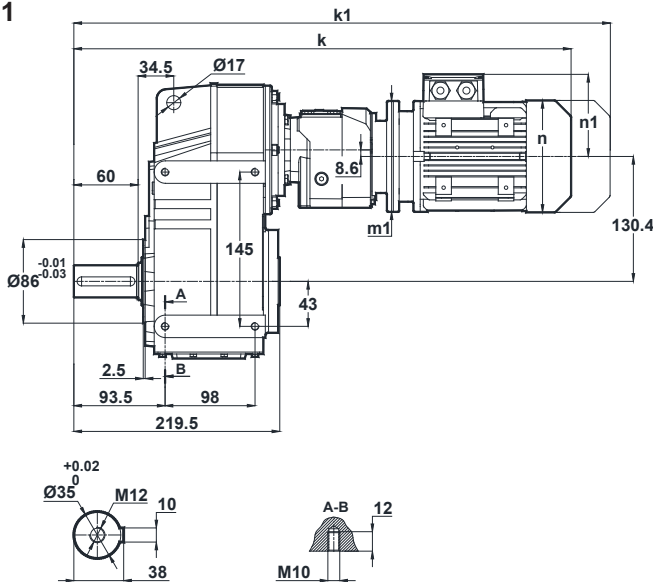

Klemens Pozisyonları  
Terminal Box Positions  
Klemmenkasten Positionen

	63/B5 63/B14	71/B5 71/B14
k	588	608
k1	649	699
n / n1	121 / 97	137 / 112
m1 (B5)	140	160
m1 (B14)	90	105
p1	309	324

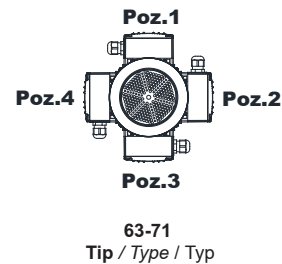

"k1" ölçüsü frenli redüktörlere aittir.  
Dimensions "k1" is for motors with brake.  
Maße "k1" ist für Bremsenmotoren.

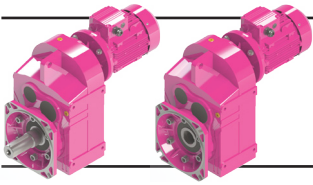

# Ölçü Sayfaları Dimension Pages Abmessungsseiten

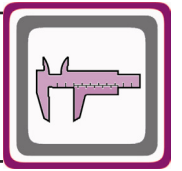

Mil ucu çektirme deliği DIN 332 sayfa 2 / Tapped center hole according to DIN 332, sheet 2 / Zentrierung mit Gewinde nach DIN 332, Blatt 2

DV275.02  
DV276.02

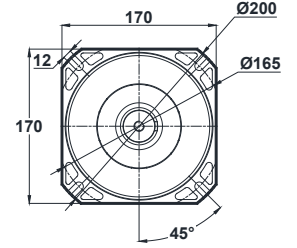
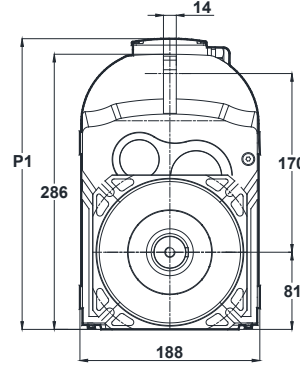
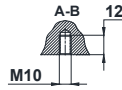
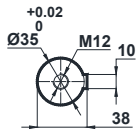
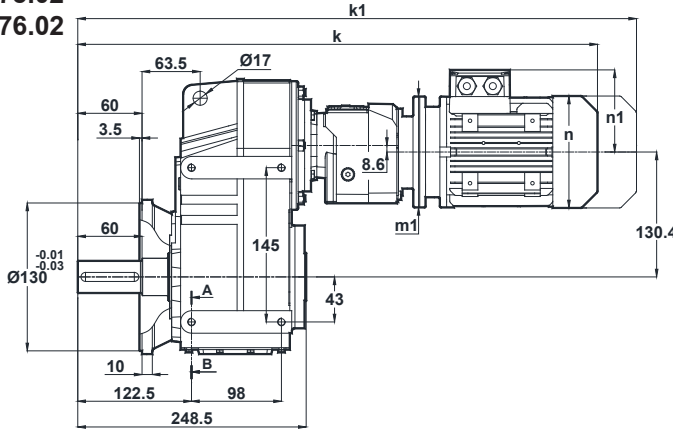

Klemens Pozisyonları  
Terminal Box Positions  
Klemmenkasten Positionen

Opsiyonel Flanş Ölçüleri  
Optional Flange Dimensions  
Auswählbare Flanschabmessungen

	63/B5 63/B14	71/B5 71/B14
k	617	637
k1	678	728
n / n1	121 / 97	137 / 112
m1 (B5)	140	160
m1 (B14)	90	105
p1	309	324

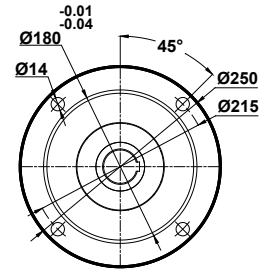
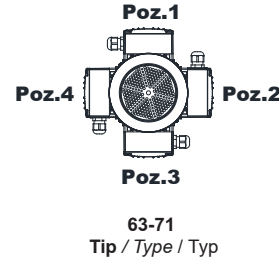

DV275.03  
DV276.03

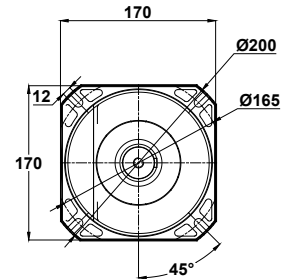
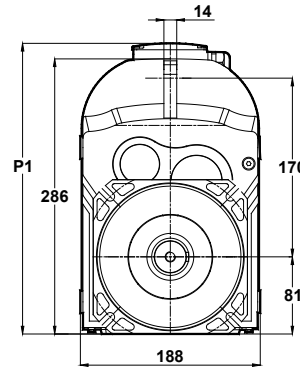
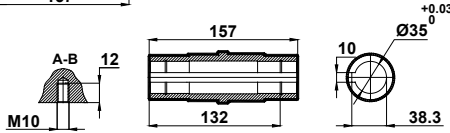
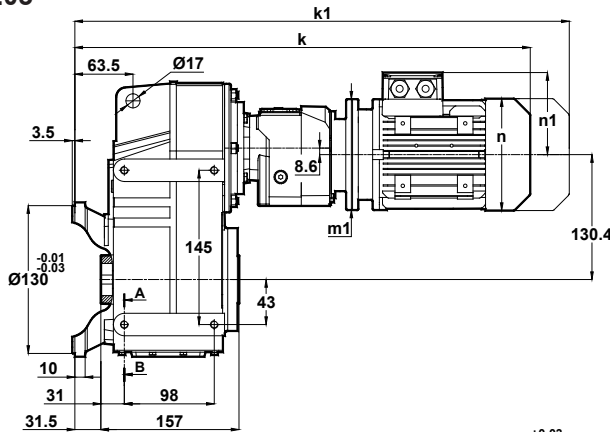

Klemens Pozisyonları  
Terminal Box Positions  
Klemmenkasten Positionen

Opsiyonel Flanş Ölçüleri  
Optional Flange Dimensions  
Auswählbare Flanschabmessungen

	63/B5 63/B14	71/B5 71/B14
k	557	577
k1	618	668
n / n1	121 / 97	137 / 112
m1 (B5)	140	160
m1 (B14)	90	105
p1	309	324

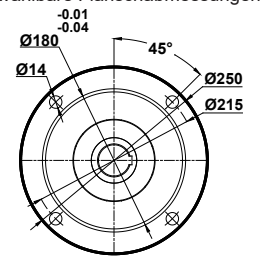
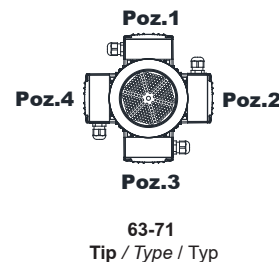

"k1" ölçüsü frenli redüktörlere aittir.  
Dimensions "k1" is for motors with brake.  
Maße "k1" ist für Bremsenmotoren.

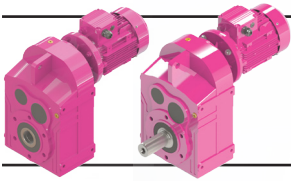

# Ölçü Sayfaları

## Dimension Pages

### Abmessungsseiten

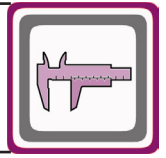

Mil ucu çektirme deliği DIN 332 sayfa 2 / Tapped center hole according to DIN 332, sheet 2 / Zentrierung mit Gewinde nach DIN 332, Blatt 2

DV282.00  
DV283.00

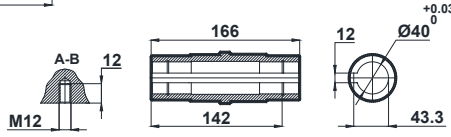
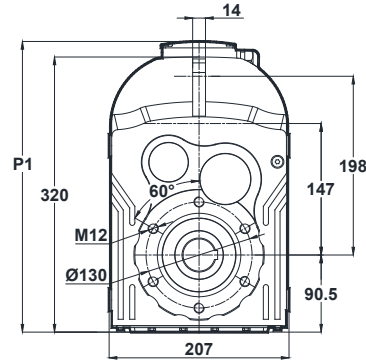
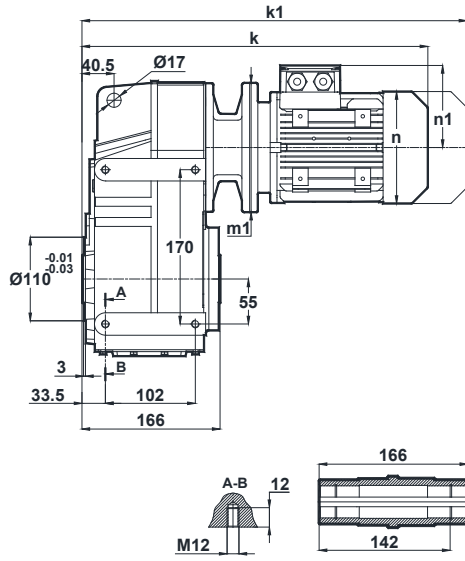

Klemens Pozisyonları  
Terminal Box Positions  
Klemmenkasten Positionen

	71/B5 71/B14	80/B5 80/B14	90S/B5 90S/B14	90L/B5 90L/B14	100L/B5 100L/B14	112M/B5 112M/B14	132S/B5 132S/B14	132M/B5 132M/B14
k	405	457	498	498	526	547	674	674
k1	496	550	602.5	602.5	645.5	651.5	804	804
n / n1	137 / 112	155 / 121	176 / 132	176 / 132	193 / 147	215 / 158	257 / 179	257 / 179
m1 (B5)	160	200	200	200	250	250	300	300
m1 (B14)	105	120	140	140	160	160	200	200
p1	349	358	369	369	384	395	417	417

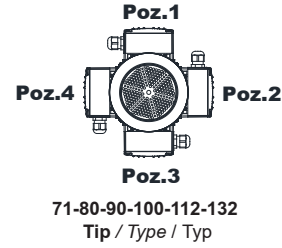

DV282.01  
DV283.01

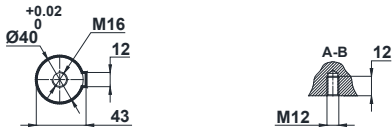
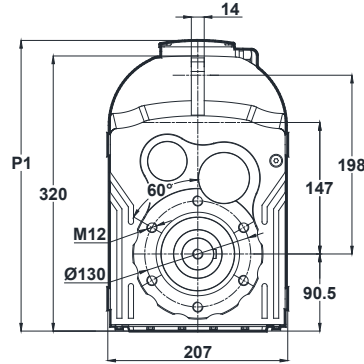
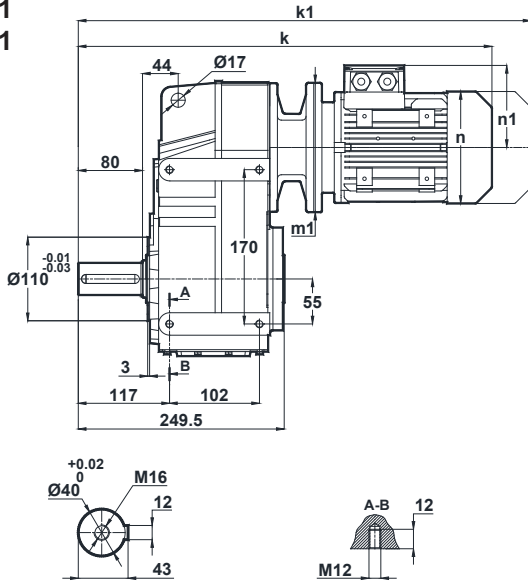

Klemens Pozisyonları  
Terminal Box Positions  
Klemmenkasten Positionen

	71/B5 71/B14	80/B5 80/B14	90S/B5 90S/B14	90L/B5 90L/B14	100L/B5 100L/B14	112M/B5 112M/B14	132S/B5 132S/B14	132M/B5 132M/B14
k	489	541	582	582	610	631	758	758
k1	580	634	686.5	686.5	729.5	735.5	888	888
n / n1	137 / 112	155 / 121	176 / 132	176 / 132	193 / 147	215 / 158	257 / 179	257 / 179
m1 (B5)	160	200	200	200	250	250	300	300
m1 (B14)	105	120	140	140	160	160	200	200
p1	349	358	369	369	384	395	417	417

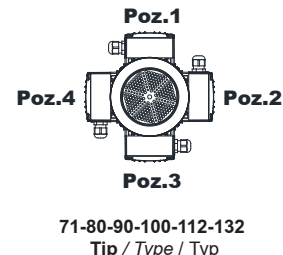

"k1" ölçüsü frenli redüktörlere aittir.  
Dimensions "k1" is for motors with brake.  
Maße "k1" ist für Bremsenmotoren.

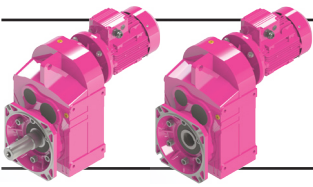

# Ölçü Sayfaları Dimension Pages Abmessungsseiten

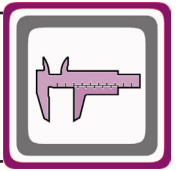

Mil ucu çektirme deliği DIN 332 sayfa 2 / Tapped center hole according to DIN 332, sheet 2 / Zentrierung mit Gewinde nach DIN 332, Blatt 2

DV282.02  
DV283.02

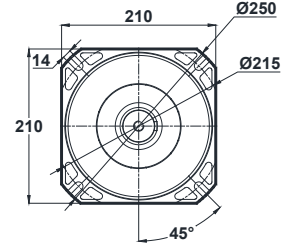
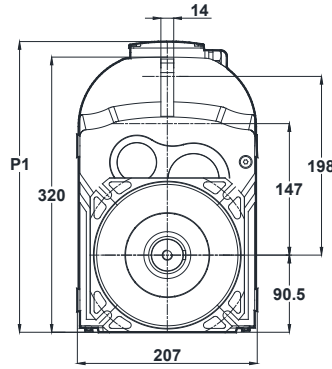
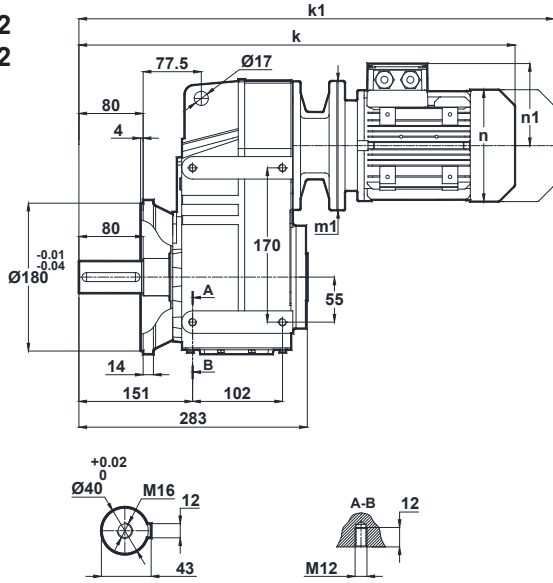

Klemens Pozisyonları  
Terminal Box Positions  
Klemmenkasten Positionen

Opsiyonel Flaş Ölçüleri  
Optional Flange Dimensions  
Auswählbare Flanschabmessungen

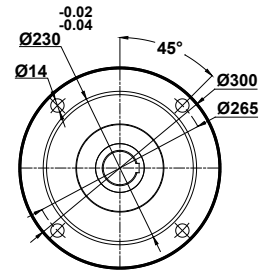
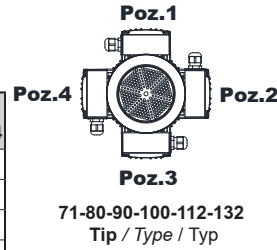

	71/B5 71/B14	80/B5 80/B14	90S/B5 90S/B14	90L/B5 90L/B14	100L/B5 100L/B14	112M/B5 112M/B14	132S/B5 132S/B14	132M/B5 132M/B14
k	522	574	615	615	643	664	791	791
k1	613	667	719.5	719.5	762.5	768.5	921	921
n / n1	137 / 112	155 / 121	176 / 132	176 / 132	193 / 147	215 / 158	257 / 179	257 / 179
m1 (B5)	160	200	200	200	250	250	300	300
m1 (B14)	105	120	140	140	160	160	200	200
p1	349	358	369	369	384	395	417	417

Diğer opsiyonel flaş ölçüleri için sayfa 326'ya bakınız.  
Please see on page 326 for other optional flange dimensions  
Siehe Seite 326 für andere auswählbare Flanschabmessungen

DV282.03  
DV283.03

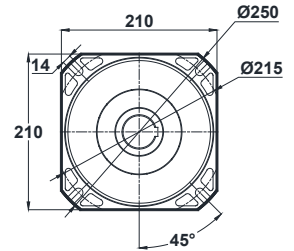
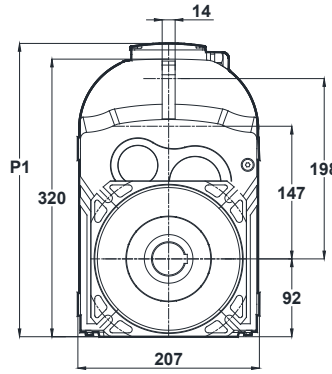
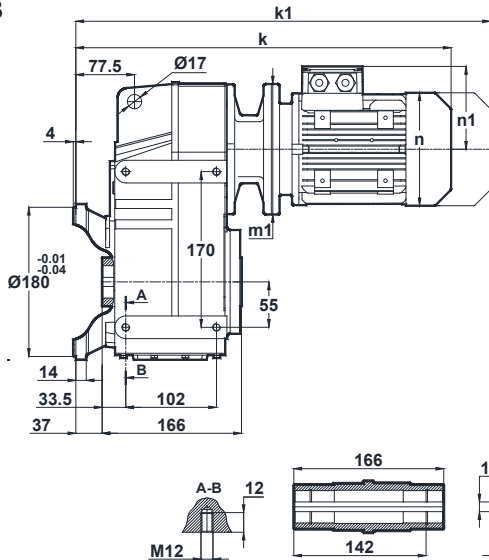

Klemens Pozisyonları  
Terminal Box Positions  
Klemmenkasten Positionen

Opsiyonel Flaş Ölçüleri  
Optional Flange Dimensions  
Auswählbare Flanschabmessungen

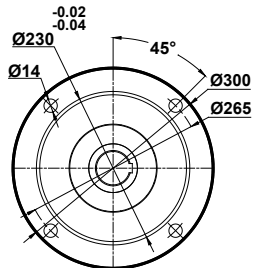
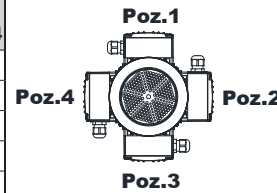

	71/B5 71/B14	80/B5 80/B14	90S/B5 90S/B14	90L/B5 90L/B14	100L/B5 100L/B14	112M/B5 112M/B14	132S/B5 132S/B14	132M/B5 132M/B14
k	442	494	535	535	563	584	711	711
k1	533	587	639.5	639.5	682.5	688.5	841	841
n / n1	137 / 112	155 / 121	176 / 132	176 / 132	193 / 147	215 / 158	257 / 179	257 / 179
m1 (B5)	160	200	200	200	250	250	300	300
m1 (B14)	105	120	140	140	160	160	200	200
p1	349	358	369	369	384	395	417	417

Diğer opsiyonel flaş ölçüleri için sayfa 326'ya bakınız.  
Please see on page 326 for other optional flange dimensions  
Siehe Seite 326 für andere auswählbare Flanschabmessungen

"k1" ölçüsü frenli redüktörlere aittir.  
Dimensions "k1" is for motors with brake.  
Maße "k1" ist für Bremsenmotoren.

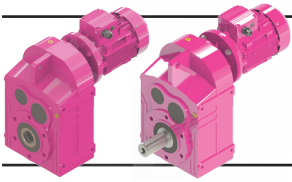

# Ölçü Sayfaları Dimension Pages Abmessungsseiten

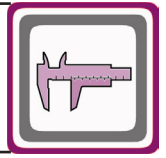

Mil ucu çektirme deliği DIN 332 sayfa 2 / Tapped center hole according to DIN 332, sheet 2 / Zentrierung mit Gewinde nach DIN 332, Blatt 2

DV285.00  
DV286.00

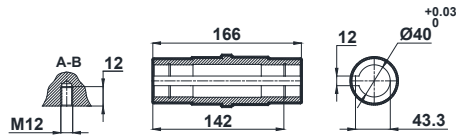
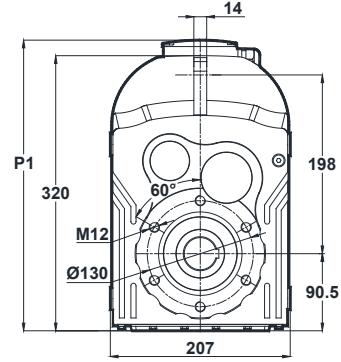
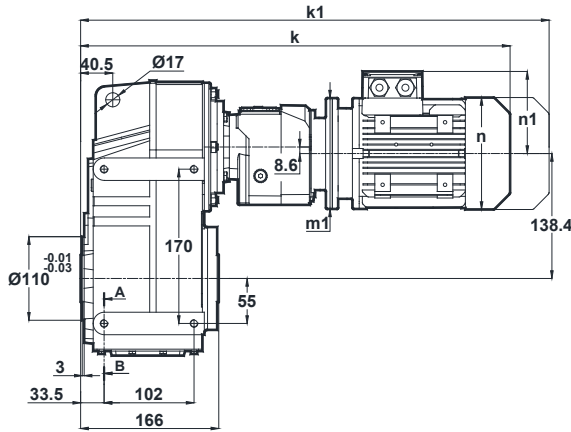

Klemens Pozisyonları  
Terminal Box Positions  
Klemmenkasten Positionen

	63/B5 63/B14	71/B5 71/B14
k	531	551
k1	592	642
n / n1	121 / 97	137 / 112
m1 (B5)	140	160
m1 (B14)	90	105
p1	326	341

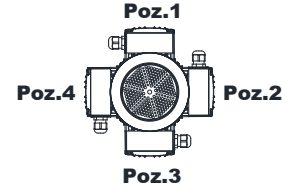

63-71  
Tip / Type / Typ

DV285.01  
DV286.01

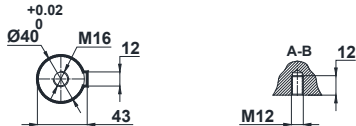
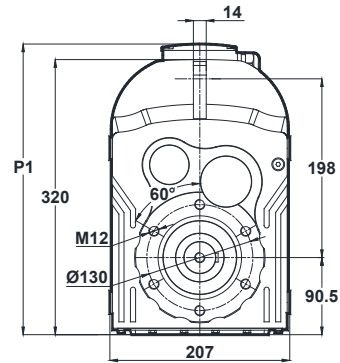
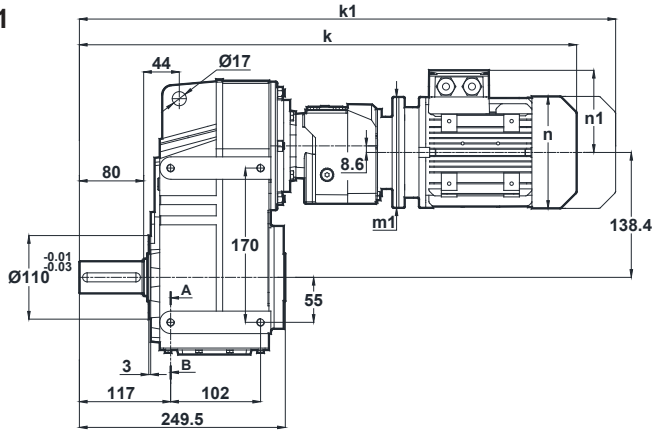

Klemens Pozisyonları  
Terminal Box Positions  
Klemmenkasten Positionen

	63/B5 63/B14	71/B5 71/B14
k	615	635
k1	676	726
n / n1	121 / 97	137 / 112
m1 (B5)	140	160
m1 (B14)	90	105
p1	326	341

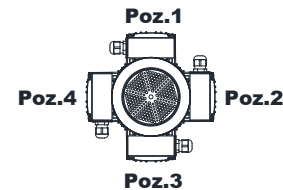

63-71  
Tip / Type / Typ

"k1" ölçüsü frenli redüktörlere aittir.  
Dimensions "k1" is for motors with brake.  
Maße "k1" ist für Bremsenmotoren.

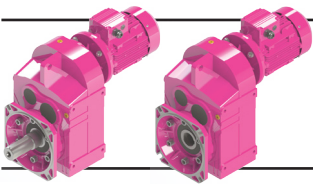

# Ölçü Sayfaları Dimension Pages Abmessungsseiten

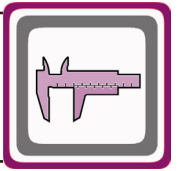

Mil ucu çektirme deliği DIN 332 sayfa 2 / Tapped center hole according to DIN 332, sheet 2 / Zentrierung mit Gewinde nach DIN 332, Blatt 2

DV285.02  
DV286.02

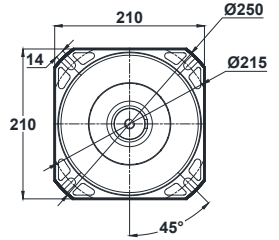
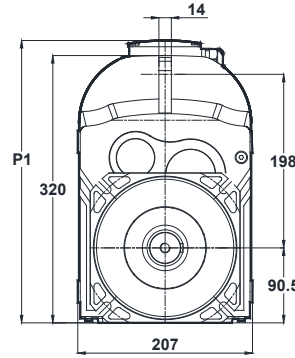
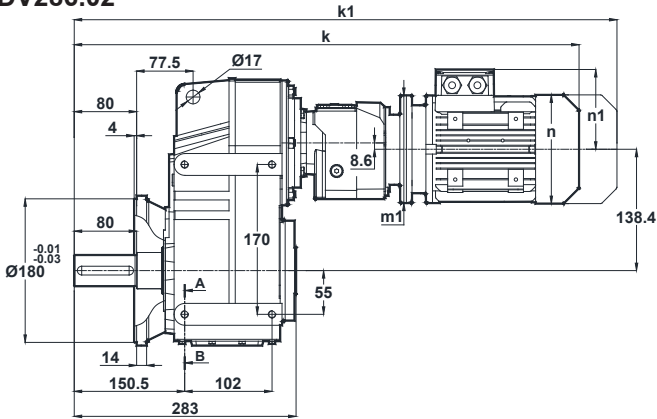

Klemens Pozisyonları  
Terminal Box Positions  
Klemmenkasten Positionen

Opsiyonel Flanş Ölçüleri  
Optional Flange Dimensions  
Auswählbare Flanschabmessungen

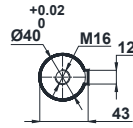
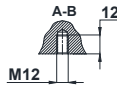

	63/B5 63/B14	71/B5 71/B14
k	648	668
k1	709	759
n / n1	121 / 97	137 / 112
m1 (B5)	140	160
m1 (B14)	90	105
p1	326	341

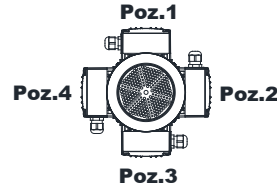

63-71  
Tip / Type / Typ

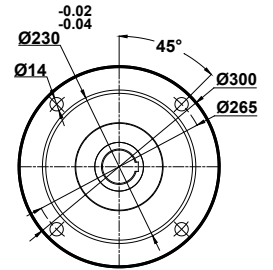

Diğer opsiyonel flanş ölçüleri için sayfa 326'ya bakınız.  
Please see on page 326 for other optional flange dimensions  
Siehe Seite 326 für andere auswählbare Flanschabmessungen

DV285.03  
DV286.03

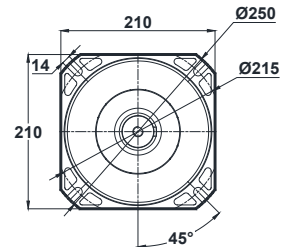
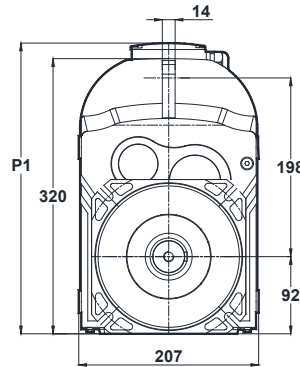
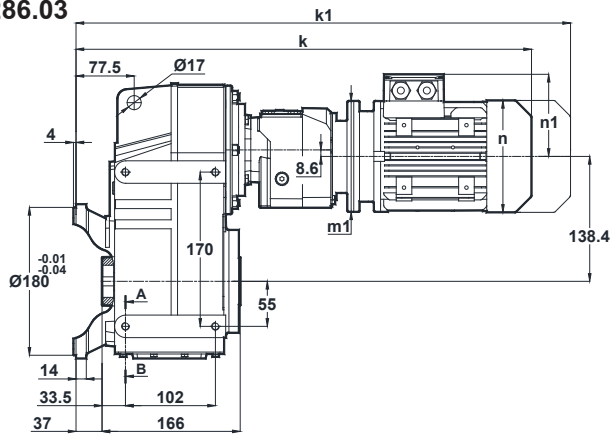

Klemens Pozisyonları  
Terminal Box Positions  
Klemmenkasten Positionen

Opsiyonel Flanş Ölçüleri  
Optional Flange Dimensions  
Auswählbare Flanschabmessungen

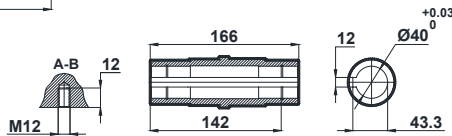

	63/B5 63/B14	71/B5 71/B14
k	568	588
k1	629	679
n / n1	121 / 97	137 / 112
m1 (B5)	140	160
m1 (B14)	90	105
p1	326	341

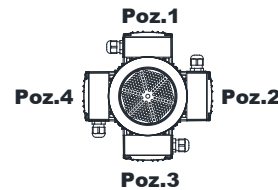

63-71  
Tip / Type / Typ

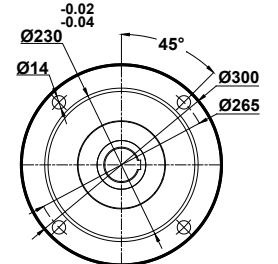

Diğer opsiyonel flanş ölçüleri için sayfa 326'ya bakınız.  
Please see on page 326 for other optional flange dimensions  
Siehe Seite 326 für andere auswählbare Flanschabmessungen

"k1" ölçüsü frenli redüktörlere aittir.  
Dimensions "k1" is for motors with brake.  
Maße "k1" ist für Bremsenmotoren.

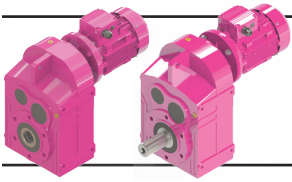

# Ölçü Sayfaları Dimension Pages Abmessungsseiten

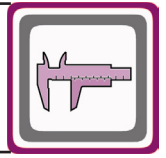

Mil ucu çektirme deliği DIN 332 sayfa 2 / Tapped center hole according to DIN 332, sheet 2 / Zentrierung mit Gewinde nach DIN 332, Blatt 2

DV372.00  
DV373.00

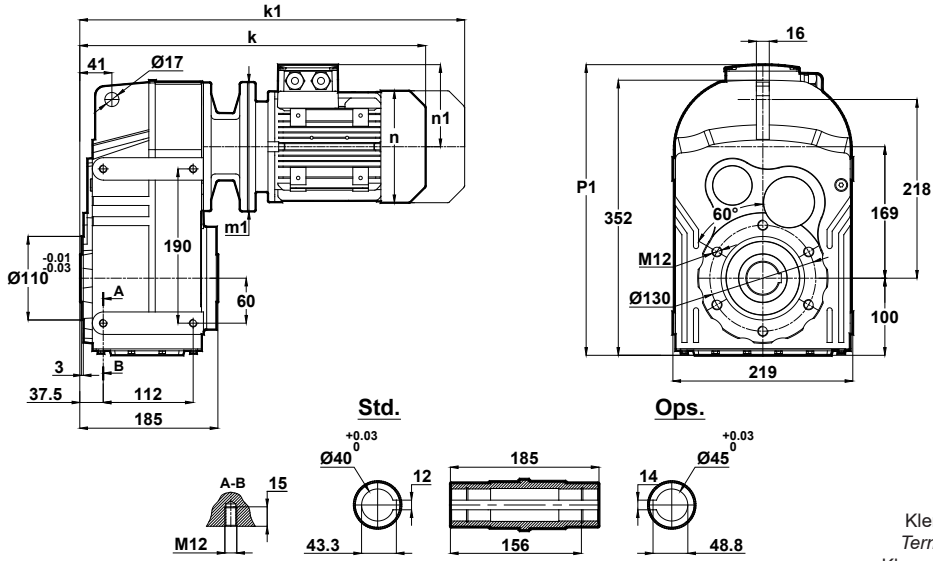

	71/B5 71/B14	80/B5 80/B14	90S/B5 90S/B14	90L/B5 90L/B14	100L/B5 100L/B14	112M/B5 112M/B14	132S/B5 132S/B14	132M/B5 132M/B14
<b>k</b>	416	468	509	509	537	558	685	685
<b>k1</b>	507	561	613.5	613.5	656.5	662.5	815	815
<b>n / n1</b>	137 / 112	155 / 121	176 / 132	176 / 132	193 / 147	215 / 158	257 / 179	257 / 179
<b>m1 (B5)</b>	160	200	200	200	250	250	300	300
<b>m1 (B14)</b>	105	120	140	140	160	160	200	200
<b>p1</b>	381	390	401	401	416	427	448	448

Klemens Pozisyonları  
Terminal Box Positions  
Klemmenkasten Positionen

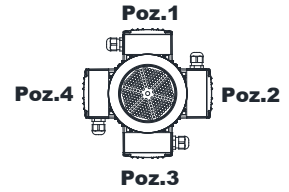

71-80-90-100-112-132  
Tip / Type / Typ

DV372.01  
DV373.01

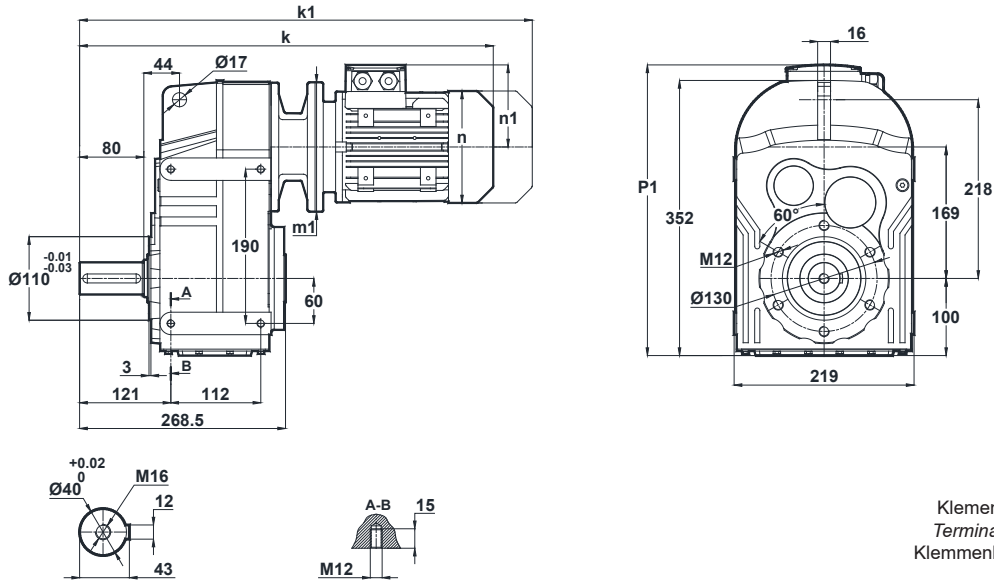

	71/B5 71/B14	80/B5 80/B14	90S/B5 90S/B14	90L/B5 90L/B14	100L/B5 100L/B14	112M/B5 112M/B14	132S/B5 132S/B14	132M/B5 132M/B14
<b>k</b>	499	551	592	592	620	641	768	768
<b>k1</b>	590	644	696.5	696.5	739.5	745.5	898	898
<b>n / n1</b>	137 / 112	155 / 121	176 / 132	176 / 132	193 / 147	215 / 158	257 / 179	257 / 179
<b>m1 (B5)</b>	160	200	200	200	250	250	300	300
<b>m1 (B14)</b>	105	120	140	140	160	160	200	200
<b>p1</b>	381	390	401	401	416	427	448	448

Klemens Pozisyonları  
Terminal Box Positions  
Klemmenkasten Positionen

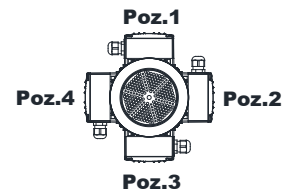

71-80-90-100-112-132  
Tip / Type / Typ

"k1" ölçüsü frenli redüktörlere aittir.  
Dimensions "k1" is for motors with brake.  
Maße "k1" ist für Bremsenmotoren.

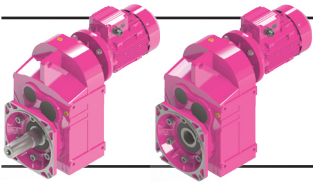

# Ölçü Sayfaları Dimension Pages Abmessungsseiten

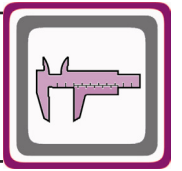

Mil ucu çektirme deliği DIN 332 sayfa 2 / Tapped center hole according to DIN 332, sheet 2 / Zentrierung mit Gewinde nach DIN 332, Blatt 2

DV372.02  
DV373.02

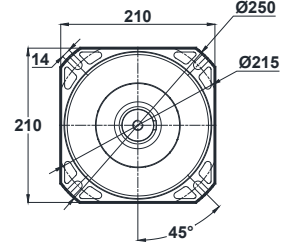
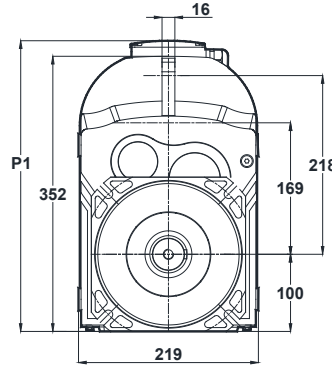
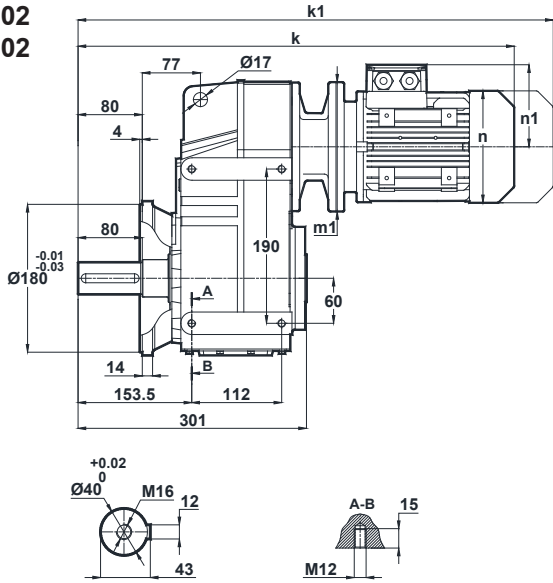

Klemens Pozisyonları  
Terminal Box Positions  
Klemmenkasten Positionen

Opsiyonel Flanş Ölçüleri  
Optional Flange Dimensions  
Auswählbare Flanschabmessungen

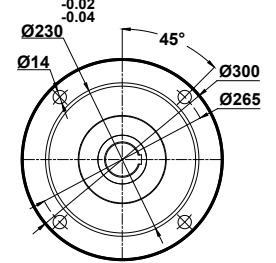
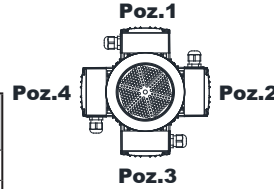

71-80-90-100-112-132  
Tip / Type / Typ

Diğer opsiyonel flanş ölçüleri için sayfa 326'ya bakınız.  
Please see on page 326 for other optional flange dimensions  
Siehe Seite 326 für andere auswählbare Flanschabmessungen

	71/B5 71/B14	80/B5 80/B14	90S/B5 90S/B14	90L/B5 90L/B14	100L/B5 100L/B14	112M/B5 112M/B14	132S/B5 132S/B14	132M/B5 132M/B14
k	532	584	625	625	653	674	801	801
k1	623	677	729.5	729.5	772.5	778.5	931	931
n / n1	137 / 112	155 / 121	176 / 132	176 / 132	193 / 147	215 / 158	257 / 179	257 / 179
m1 (B5)	160	200	200	200	250	250	300	300
m1 (B14)	105	120	140	140	160	160	200	200
p1	381	390	401	401	416	427	448	448

DV372.03  
DV373.03

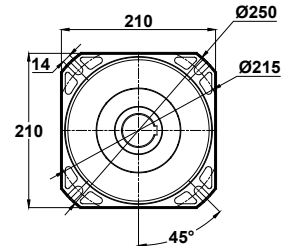
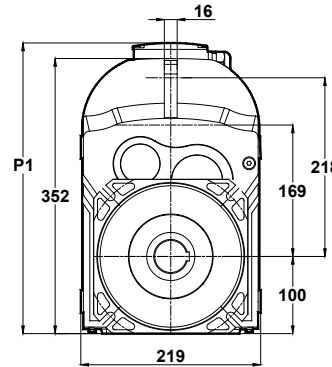
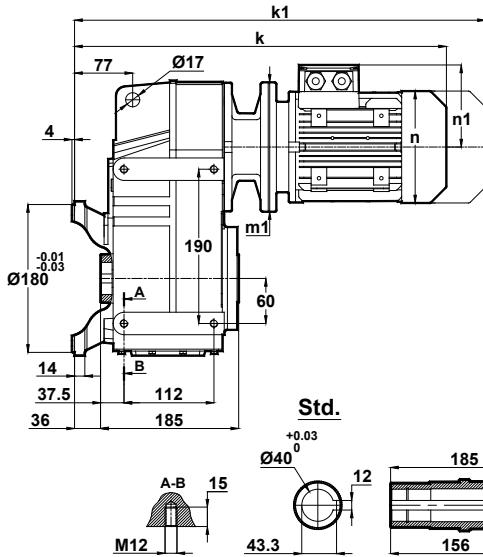

Klemens Pozisyonları  
Terminal Box Positions  
Klemmenkasten Positionen

Opsiyonel Flanş Ölçüleri  
Optional Flange Dimensions  
Auswählbare Flanschabmessungen

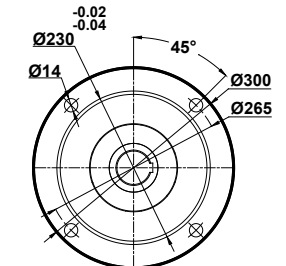
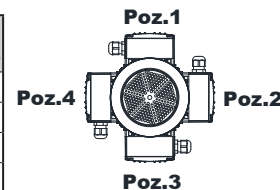

71-80-90-100-112-132  
Tip / Type / Typ

	71/B5 71/B14	80/B5 80/B14	90S/B5 90S/B14	90L/B5 90L/B14	100L/B5 100L/B14	112M/B5 112M/B14	132S/B5 132S/B14	132M/B5 132M/B14
k	452	504	545	545	573	594	721	721
k1	543	597	649.5	649.5	692.5	698.5	851	851
n / n1	137 / 112	155 / 121	176 / 132	176 / 132	193 / 147	215 / 158	257 / 179	257 / 179
m1 (B5)	160	200	200	200	250	250	300	300
m1 (B14)	105	120	140	140	160	160	200	200
p1	381	390	401	401	416	427	448	448

"k1" ölçüsü frenli redüktörlere aittir.  
Dimensions "k1" is for motors with brake.  
Maße "k1" ist für Bremsenmotoren.

Diğer opsiyonel flanş ölçüleri için sayfa 326'ya bakınız.  
Please see on page 326 for other optional flange dimensions  
Siehe Seite 326 für andere auswählbare Flanschabmessungen

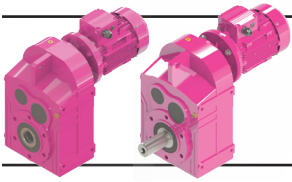

# Ölçü Sayfaları Dimension Pages Abmessungsseiten

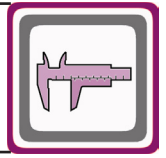

Mil ucu çektirme deliği DIN 332 sayfa 2 / Tapped center hole according to DIN 332, sheet 2 / Zentrierung mit Gewinde nach DIN 332, Blatt 2

DV375.00  
DV376.00

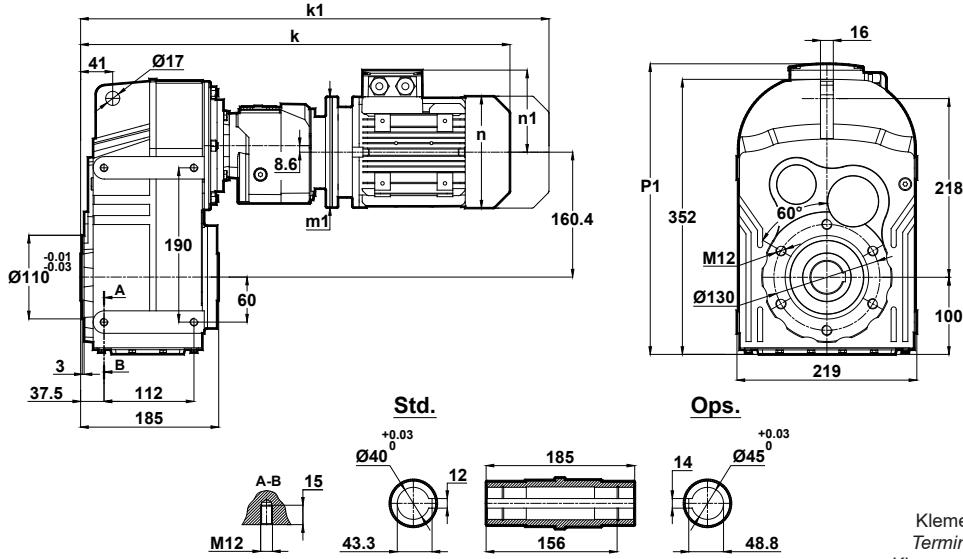

	63/B5 63/B14	71/B5 71/B14	80/B5 80/B14
k	542	562	600
k1	603	653	693
n / n1	121 / 97	137 / 112	155 / 121
m1 (B5)	140	160	200
m1 (B14)	90	105	120
p1	358	373	382

Klemens Pozisyonları  
Terminal Box Positions  
Klemmenkasten Positionen

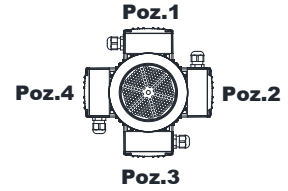

63-71-80  
Tip / Type / Typ

DV375.01  
DV376.01

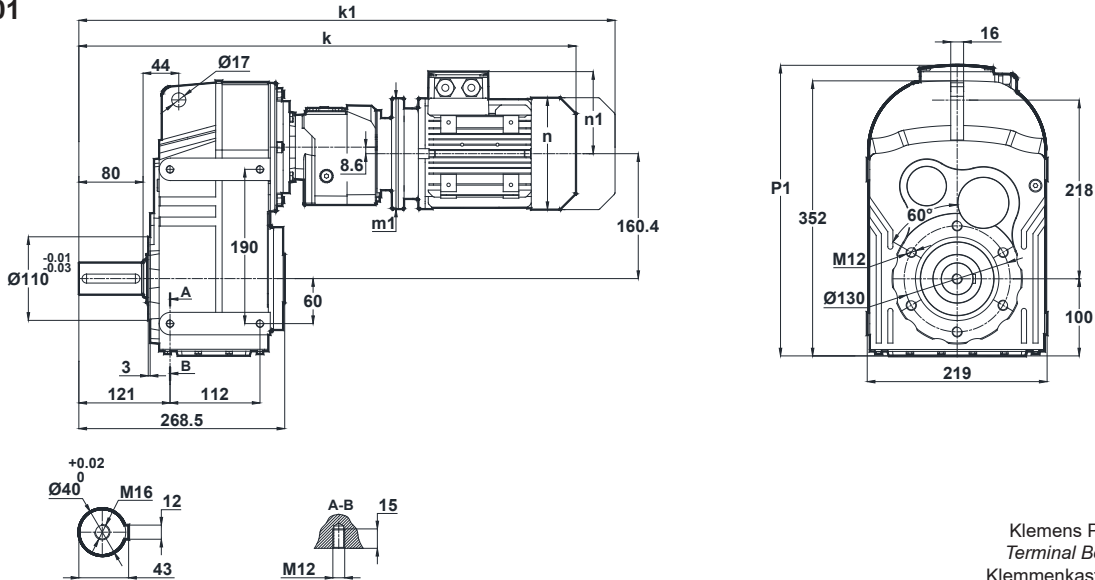

	63/B5 63/B14	71/B5 71/B14	80/B5 80/B14
k	625	645	683
k1	686	736	776
n / n1	121 / 97	137 / 112	155 / 121
m1 (B5)	140	160	200
m1 (B14)	90	105	120
p1	358	373	382

Klemens Pozisyonları  
Terminal Box Positions  
Klemmenkasten Positionen

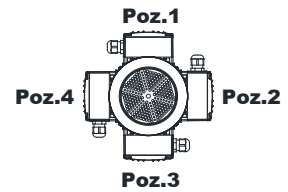

63-71-80  
Tip / Type / Typ

"k1" ölçüsü frenli redüktörlere aittir.  
Dimensions "k1" is for motors with brake.  
Maße "k1" ist für Bremsenmotoren.

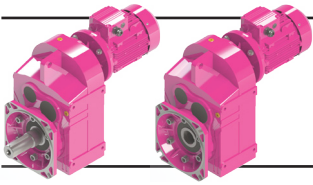

# Ölçü Sayfaları Dimension Pages Abmessungsseiten

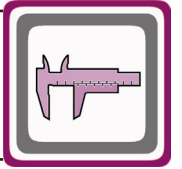

Mil ucu çektirme deliği DIN 332 sayfa 2 / Tapped center hole according to DIN 332, sheet 2 / Zentrierung mit Gewinde nach DIN 332, Blatt 2

DV375.02  
DV376.02

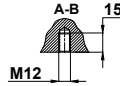
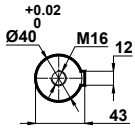
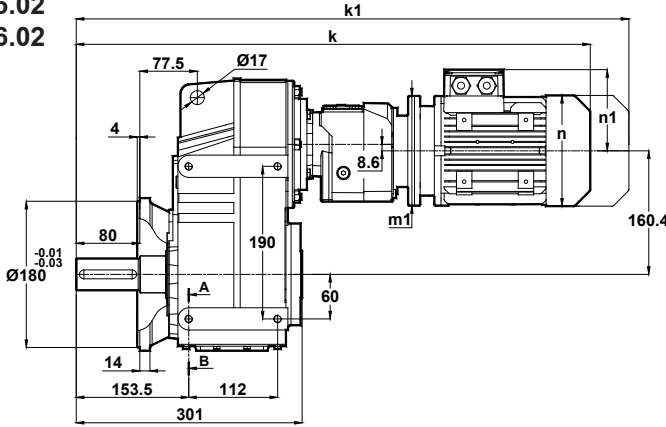

	63/B5 63/B14	71/B5 71/B14	80/B5 80/B14
k	658	678	716
k1	719	769	809
n / n1	121 / 97	137 / 112	155 / 121
m1 (B5)	140	160	200
m1 (B14)	90	105	120
p1	358	373	382

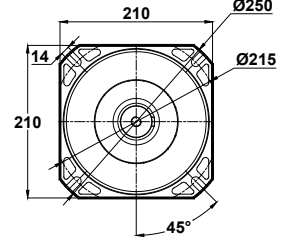
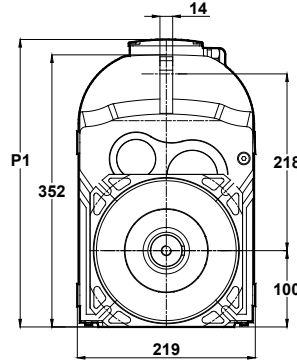

Klemens Pozisyonları  
Terminal Box Positions  
Klemmenkasten Positionen

Opsiyonel Flanş Ölçüleri  
Optional Flange Dimensions  
Auswählbare Flanschabmessungen

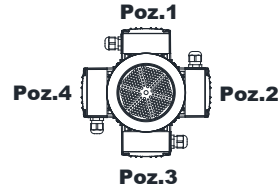

63-71-80  
Tip / Type / Typ

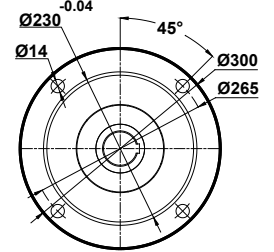

Diğer opsiyonel flanş ölçüleri için sayfa 326'ya bakınız.  
Please see on page 326 for other optional flange dimensions  
Siehe Seite 326 für andere auswählbare Flanschabmessungen

DV375.03  
DV376.03

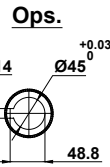
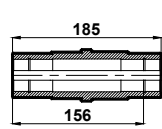
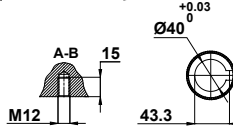
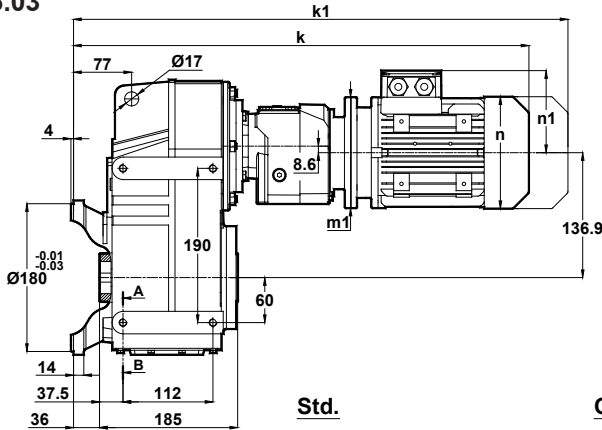

	63/B5 63/B14	71/B5 71/B14	80/B5 80/B14
k	578	598	636
k1	639	689	729
n / n1	121 / 97	137 / 112	155 / 121
m1 (B5)	140	160	200
m1 (B14)	90	105	120
p1	358	373	382

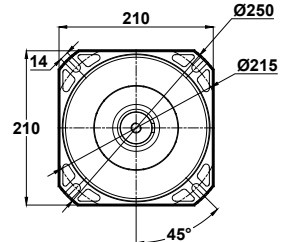
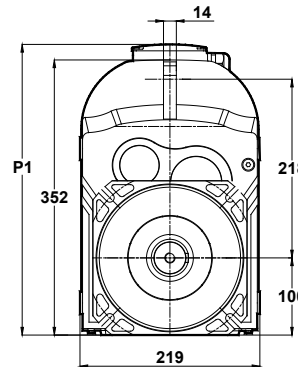

Klemens Pozisyonları  
Terminal Box Positions  
Klemmenkasten Positionen

Opsiyonel Flanş Ölçüleri  
Optional Flange Dimensions  
Auswählbare Flanschabmessungen

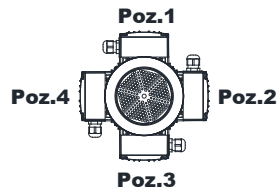

63-71-80  
Tip / Type / Typ

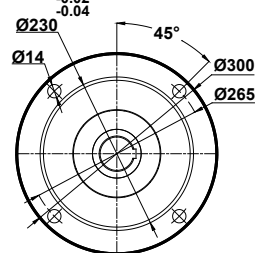

Diğer opsiyonel flanş ölçüleri için sayfa 326'ya bakınız.  
Please see on page 326 for other optional flange dimensions  
Siehe Seite 326 für andere auswählbare Flanschabmessungen

"k1" ölçüsü frenli redüktörlere aittir.  
Dimensions "k1" is for motors with brake.  
Maße "k1" ist für Bremsenmotoren.

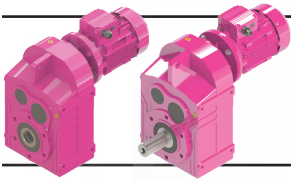

# Ölçü Sayfaları Dimension Pages Abmessungsseiten

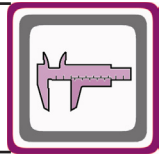

Mil ucu çektirme deliği DIN 332 sayfa 2 / Tapped center hole according to DIN 332, sheet 2 / Zentrierung mit Gewinde nach DIN 332, Blatt 2

DV472.00  
DV473.00

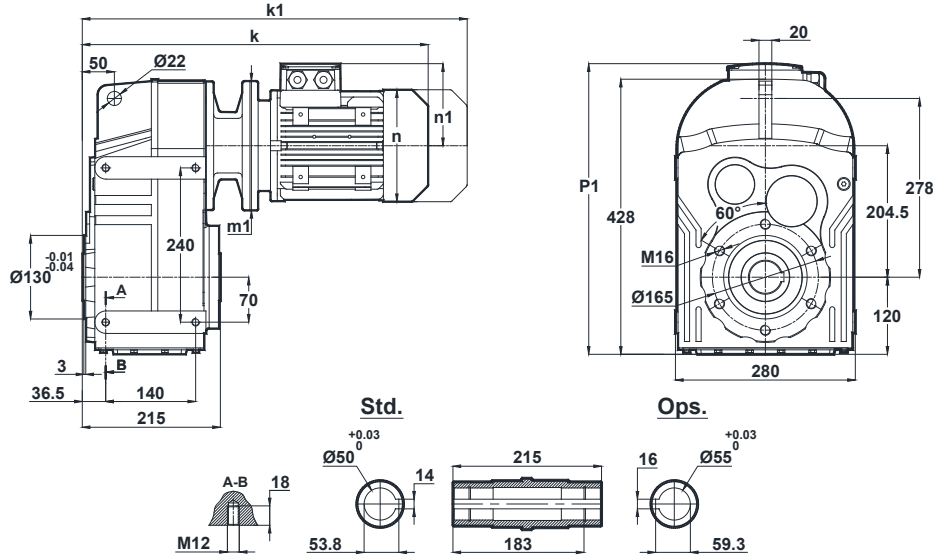

Klemens Pozisyonları  
Terminal Box Positions  
Klemmenkasten Positionen

	71/B5	80/B5 80/B14	90S/B5 90S/B14	90L/B5 90L/B14	100L/B5 100L/B14	112M/B5 112M/B14	132S/B5 132S/B14	132M/B5 132M/B14	160M/B5	160L/B5
k	471	494	535	535	587	608	712	712	871	871
k1	562	587	639.5	639.5	706.5	712.5	842	842	1051	1051
n / n1	137 / 112	155 / 121	176 / 132	176 / 132	193 / 147	215 / 158	257 / 179	257 / 179	315 / 219	315 / 219
m1 (B5)	160	200	200	200	250	250	300	300	350	350
m1 (B14)	-	120	140	140	160	160	200	200	-	-
p1	437	446	457	457	472	483	504	504	544	544

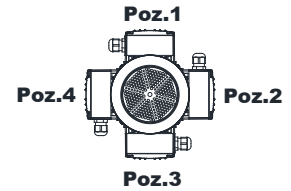

71-80-90-100-112-132-160  
Tip / Type / Typ

DV472.01  
DV473.01

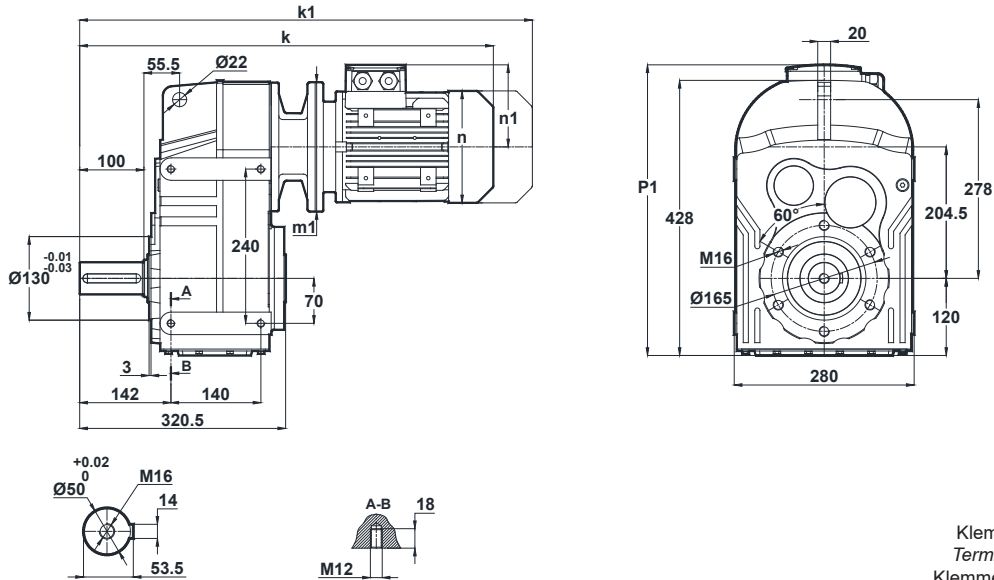

Klemens Pozisyonları  
Terminal Box Positions  
Klemmenkasten Positionen

	71/B5	80/B5 80/B14	90S/B5 90S/B14	90L/B5 90L/B14	100L/B5 100L/B14	112M/B5 112M/B14	132S/B5 132S/B14	132M/B5 132M/B14	160M/B5	160L/B5
k	576	599	640	640	692	713	817	817	976	976
k1	667	692	744.5	744.5	811.5	817.5	947	947	1156	1156
n / n1	137 / 112	155 / 121	176 / 132	176 / 132	193 / 147	215 / 158	257 / 179	257 / 179	315 / 219	315 / 219
m1 (B5)	160	200	200	200	250	250	300	300	350	350
m1 (B14)	-	120	140	140	160	160	200	200	-	-
p1	437	446	457	457	472	483	504	504	544	544

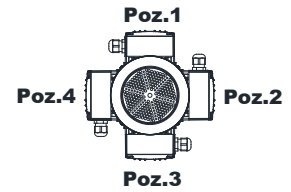

71-80-90-100-112-132-160  
Tip / Type / Typ

"k1" ölçüsü frenli redüktörlere aittir.  
Dimensions "k1" is for motors with brake.  
Maße "k1" ist für Bremsenmotoren.

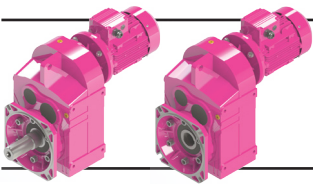

# Ölçü Sayfaları Dimension Pages Abmessungsseiten

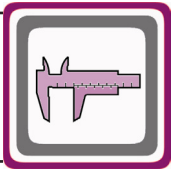

Mil ucu çektirme deliği DIN 332 sayfa 2 / Tapped center hole according to DIN 332, sheet 2 / Zentrierung mit Gewinde nach DIN 332, Blatt 2

DV472.02  
DV473.02

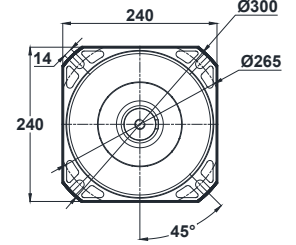
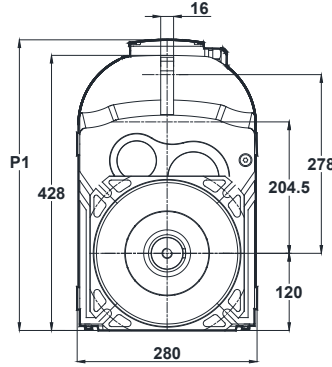
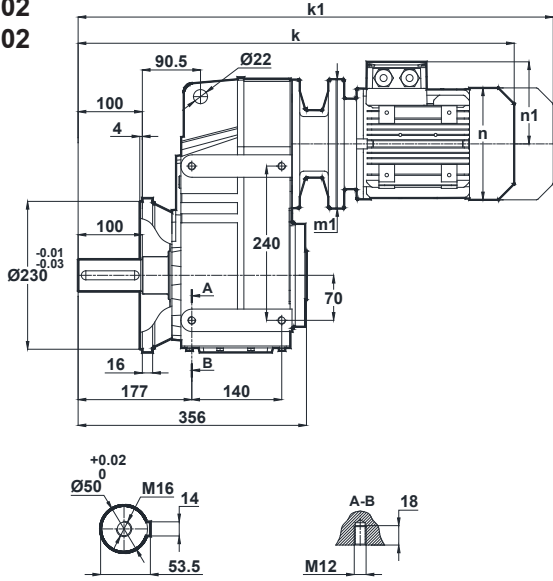

Klemens Pozisyonları  
Terminal Box Positions  
Klemmenkasten Positionen

Opsiyonel Flanş Ölçüleri  
Optional Flange Dimensions  
Auswählbare Flanschabmessungen

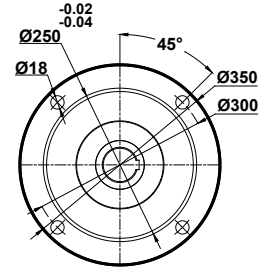
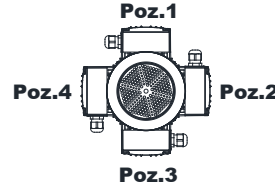

71-80-90-100-112-132-160  
Tip / Type / Typ

Diğer opsiyonel flanş ölçüleri için sayfa 326'ya bakınız.  
Please see on page 326 for other optional flange dimensions  
Siehe Seite 326 für andere auswählbare Flanschabmessungen

	71/B5	80/B5 80/B14	90S/B5 90S/B14	90L/B5 90L/B14	100L/B5 100L/B14	112M/B5 112M/B14	132S/B5 132S/B14	132M/B5 132M/B14	160M/B5	160L/B5
k	611	634	675	675	727	748	852	852	1011	1011
k1	702	727	779.5	779.5	846.5	852.5	982	982	1191	1191
n / n1	137 / 112	155 / 121	176 / 132	176 / 132	193 / 147	215 / 158	257 / 179	257 / 179	315 / 219	315 / 219
m1 (B5)	160	200	200	200	250	250	300	300	350	350
m1 (B14)	-	120	140	140	160	160	200	200	-	-
p1	437	446	457	457	472	483	504	504	544	544

DV472.03  
DV473.03

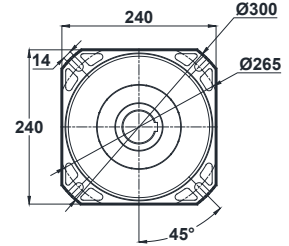
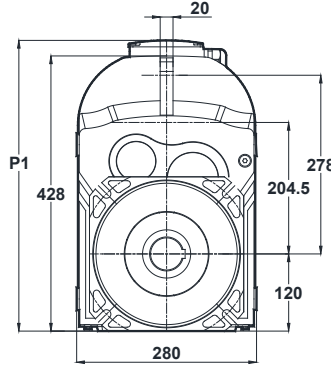
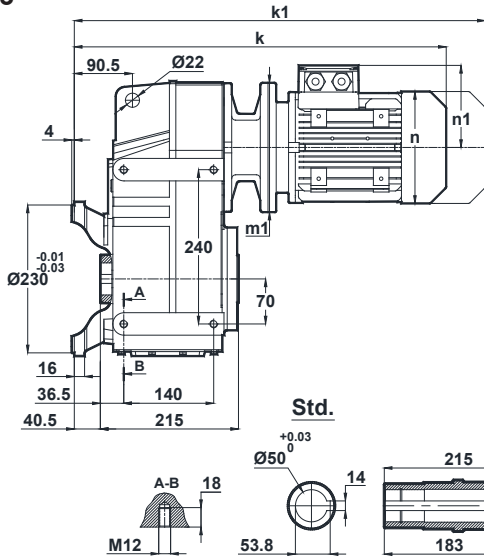

Klemens Pozisyonları  
Terminal Box Positions  
Klemmenkasten Positionen

Opsiyonel Flanş Ölçüleri  
Optional Flange Dimensions  
Auswählbare Flanschabmessungen

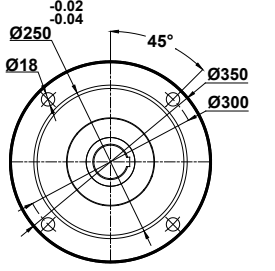
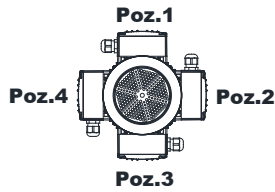

71-80-90-100-112-132-160  
Tip / Type / Typ

	71/B5	80/B5 80/B14	90S/B5 90S/B14	90L/B5 90L/B14	100L/B5 100L/B14	112M/B5 112M/B14	132S/B5 132S/B14	132M/B5 132M/B14	160M/B5	160L/B5
k	511	534	575	575	627	648	752	752	911	911
k1	602	627	679.5	679.5	746.5	752.5	882	882	1091	1091
n / n1	137 / 112	155 / 121	176 / 132	176 / 132	193 / 147	215 / 158	257 / 179	257 / 179	315 / 219	315 / 219
m1 (B5)	160	200	200	200	250	250	300	300	350	350
m1 (B14)	-	120	140	140	160	160	200	200	-	-
p1	437	446	457	457	472	483	504	504	544	544

"k1" ölçüsü frenli redüktörlere aittir.  
Dimensions "k1" is for motors with brake.  
Maße "k1" ist für Bremsenmotoren.

Diğer opsiyonel flanş ölçüleri için sayfa 326'ya bakınız.  
Please see on page 326 for other optional flange dimensions  
Siehe Seite 326 für andere auswählbare Flanschabmessungen

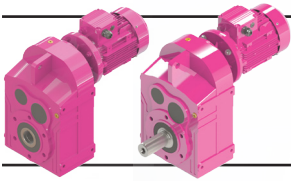

# Ölçü Sayfaları

## Dimension Pages

### Abmessungsseiten

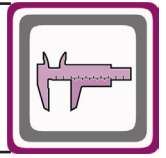

Mil ucu çekirme deliği DIN 332 sayfa 2 / Tapped center hole according to DIN 332, sheet 2 / Zentrierung mit Gewinde nach DIN 332, Blatt 2

#### DV474.00

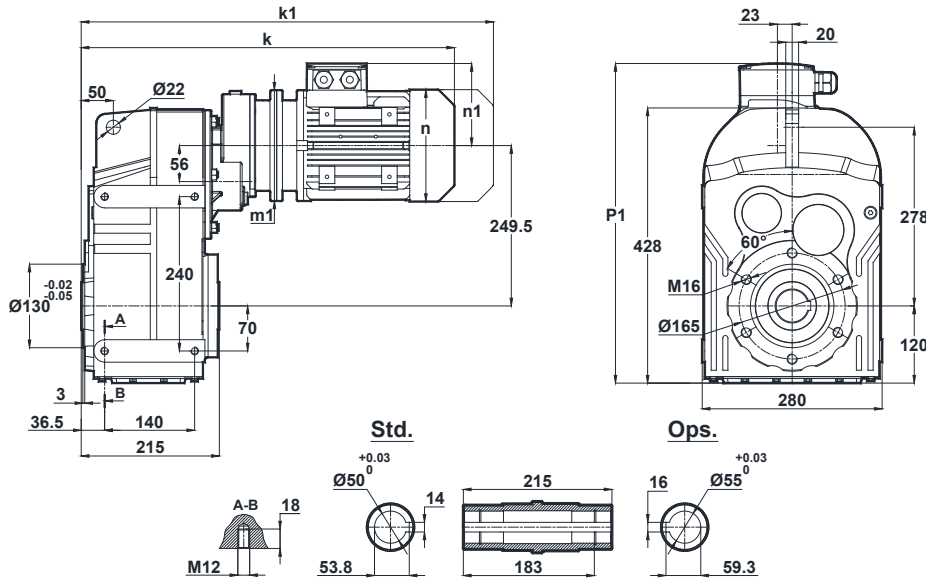

Klemens Pozisyonları  
Terminal Box Positions  
Klemmenkasten Positionen

	63/B5	71/B5 71/B14	80/B5 80/B14
k	530	519	577
k1	591	610	670
n / n1	121 / 97	137 / 112	155 / 121
m1 (B5)	140	160	200
m1 (B14)	-	105	120
p1	467	482	491

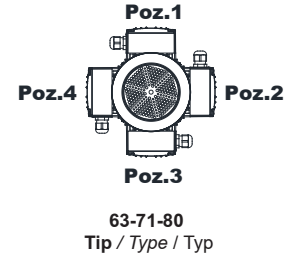

#### DV474.01

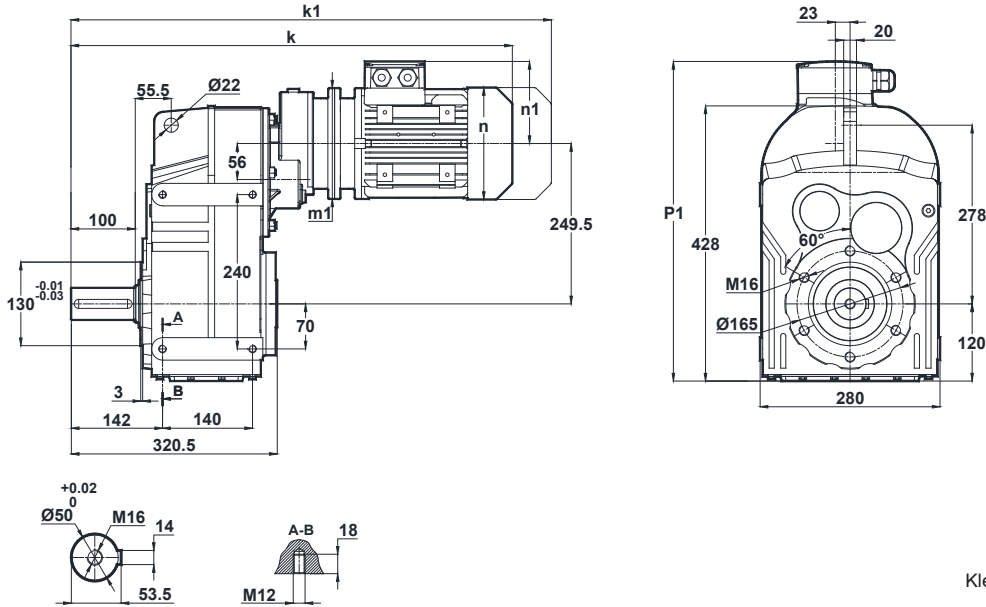

Klemens Pozisyonları  
Terminal Box Positions  
Klemmenkasten Positionen

	63/B5	71/B5 71/B14	80/B5 80/B14
k	898	624	682
k1	959	715	775
n / n1	121 / 97	137 / 112	155 / 121
m1 (B5)	140	160	200
m1 (B14)	-	105	120
p1	467	482	491

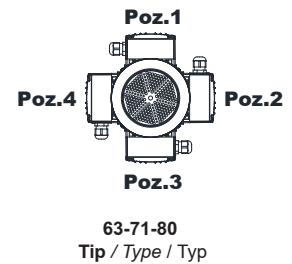

"k1" ölçüsü frenli redüktörlere aittir.  
Dimensions "k1" is for motors with brake.  
Maße "k1" ist für Bremsenmotoren.

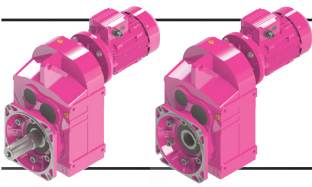

# Ölçü Sayfaları Dimension Pages Abmessungsseiten

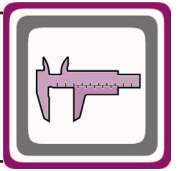

Mil ucu çektirme deliği DIN 332 sayfa 2 / Tapped center hole according to DIN 332, sheet 2 / Zentrierung mit Gewinde nach DIN 332, Blatt 2

## DV474.02

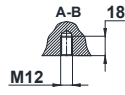
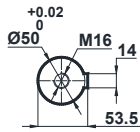
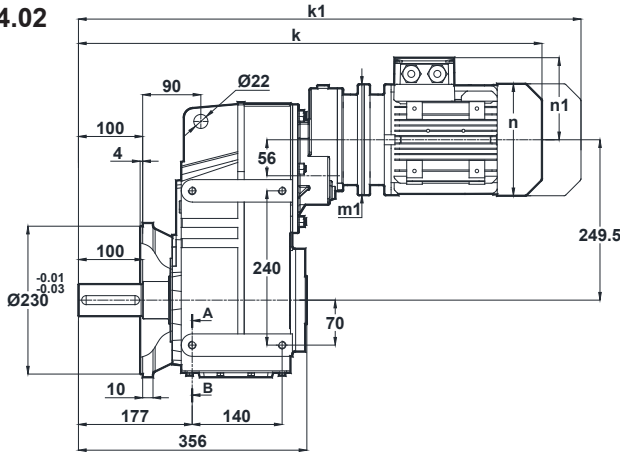

	63/B5	71/B5 71/B14	80/B5 80/B14
k	670	659	717
k1	731	750	810
n / n1	121 / 97	137 / 112	155 / 121
m1 (B5)	140	160	200
m1 (B14)	-	105	120
p1	467	482	491

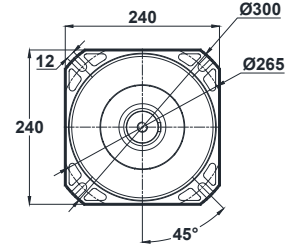
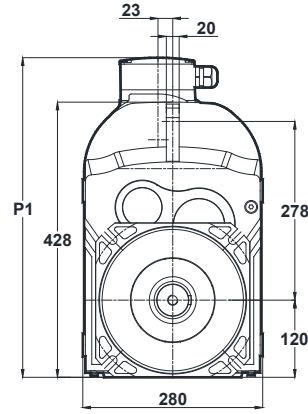

Klemens Pozisyonları  
Terminal Box Positions  
Klemmenkasten Positionen

Opsiyonel Flanş Ölçüleri  
Optional Flange Dimensions  
Auswählbare Flanschabmessungen

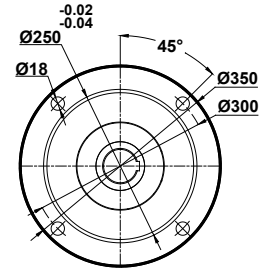
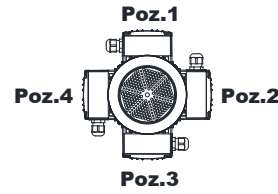

63-71-80  
Tip / Type / Typ

Diğer opsiyonel flanş ölçüleri için sayfa 326'ya bakınız.  
Please see on page 326 for other optional flange dimensions  
Siehe Seite 326 für andere auswählbare Flanschabmessungen

## DV474.03

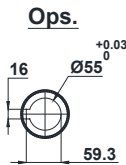
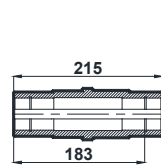
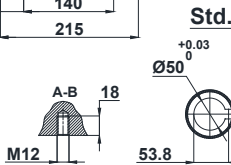
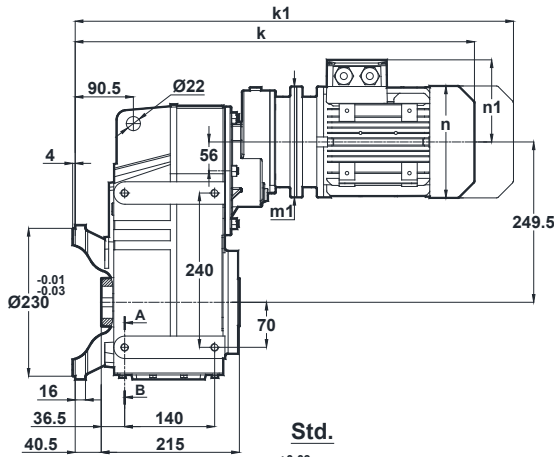

	63/B5	71/B5 71/B14	80/B5 80/B14
k	833	559	617
k1	894	650	710
n / n1	121 / 97	137 / 112	155 / 121
m1 (B5)	140	160	200
m1 (B14)	-	105	120
p1	467	482	491

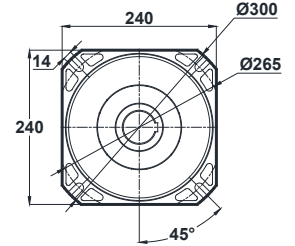
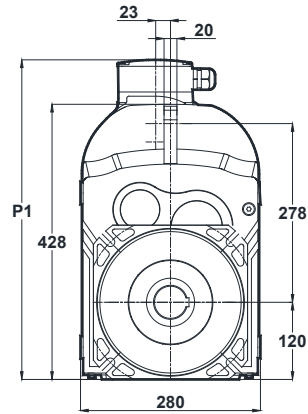

Klemens Pozisyonları  
Terminal Box Positions  
Klemmenkasten Positionen

Opsiyonel Flanş Ölçüleri  
Optional Flange Dimensions  
Auswählbare Flanschabmessungen

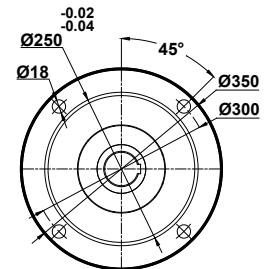
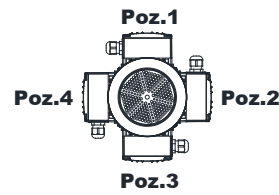

63-71-80  
Tip / Type / Typ

Diğer opsiyonel flanş ölçüleri için sayfa 326'ya bakınız.  
Please see on page 326 for other optional flange dimensions  
Siehe Seite 326 für andere auswählbare Flanschabmessungen

"k1" ölçüsü frenli redüktörlere aittir.  
Dimensions "k1" is for motors with brake.  
Maße "k1" ist für Bremsenmotoren.

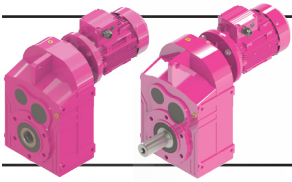

# Ölçü Sayfaları

## Dimension Pages

### Abmessungsseiten

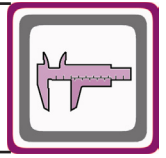

Mil ucu çektirme deliği DIN 332 sayfa 2 / Tapped center hole according to DIN 332, sheet 2 / Zentrierung mit Gewinde nach DIN 332, Blatt 2

DV475.00  
DV476.00

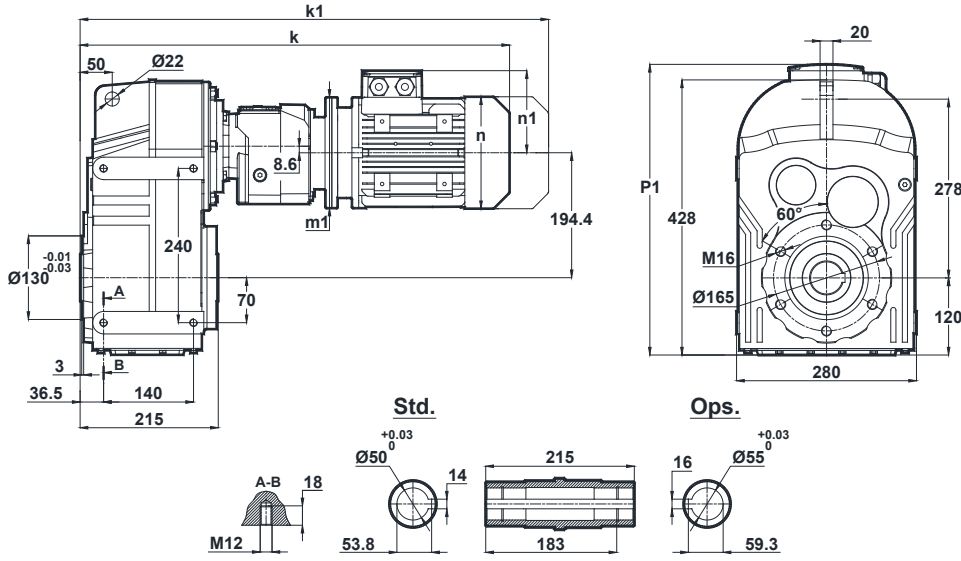

Klemens Pozisyonları  
Terminal Box Positions  
Klemmenkasten Positionen

	63/B5 63/B14	71/B5 71/B14
k	595	614
k1	656	705
n / n1	121 / 97	137 / 112
m1 (B5)	140	160
m1 (B14)	90	105
p1	-	-

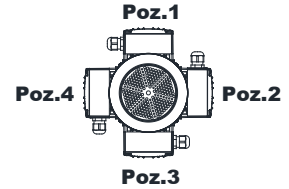

63-71  
Tip / Type / Typ

DV475.01  
DV476.01

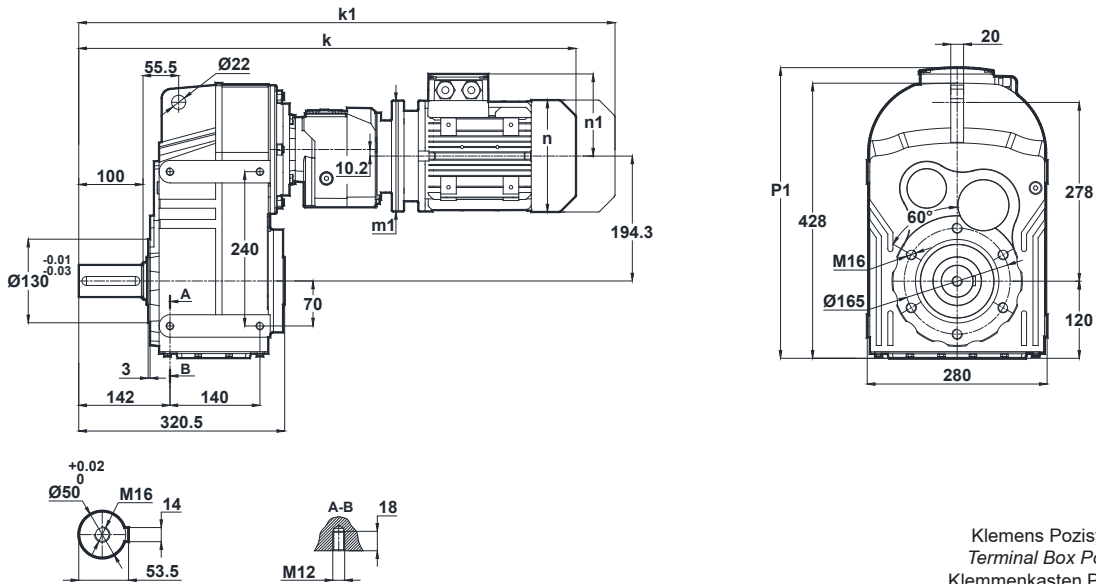

Klemens Pozisyonları  
Terminal Box Positions  
Klemmenkasten Positionen

	63/B5 63/B14	71/B5 71/B14
k	700	719
k1	761	810
n / n1	121 / 97	137 / 112
m1 (B5)	140	160
m1 (B14)	90	105
p1	-	-

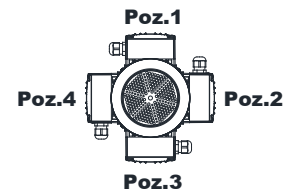

63-71  
Tip / Type / Typ

"k1" ölçüsü frenli redüktörlere aittir.  
Dimensions "k1" is for motors with brake.  
Maße "k1" ist für Bremsenmotoren.

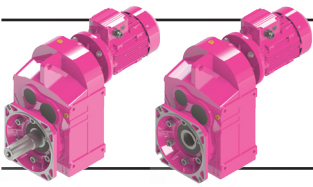

# Ölçü Sayfaları Dimension Pages Abmessungsseiten

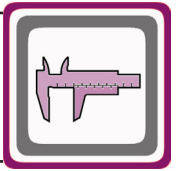

Mil ucu çektirme deliği DIN 332 sayfa 2 / Tapped center hole according to DIN 332, sheet 2 / Zentrierung mit Gewinde nach DIN 332, Blatt 2

DV475.02  
DV476.02

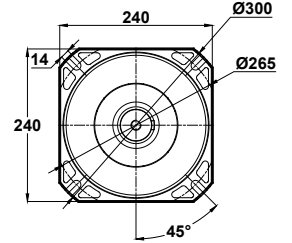
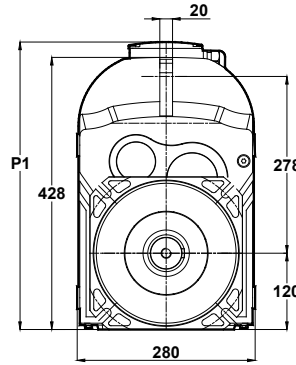
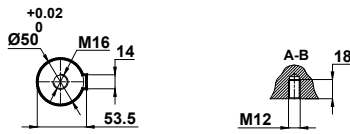
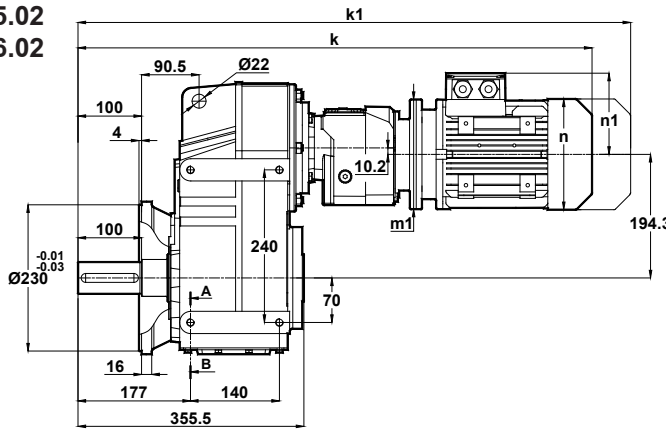

Klemens Pozisyonları  
Terminal Box Positions  
Klemmenkasten Positionen

Opsiyonel Flaş Ölçüleri  
Optional Flange Dimensions  
Auswählbare Flanschabmessungen

	63/B5 63/B14	71/B5 71/B14
k	735	754
k1	796	845
n / n1	121 / 97	137 / 112
m1 (B5)	140	160
m1 (B14)	90	105
p1	-	-

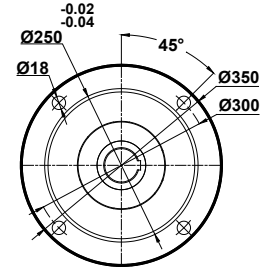
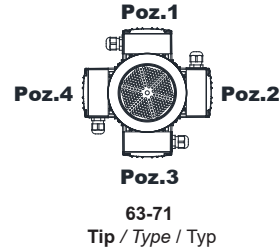

63-71  
Tip / Type / Typ

Diğer opsiyonel flaş ölçüleri için sayfa 326'ya bakınız.  
Please see on page 326 for other optional flange dimensions  
Siehe Seite 326 für andere auswählbare Flanschabmessungen

DV475.03  
DV476.03

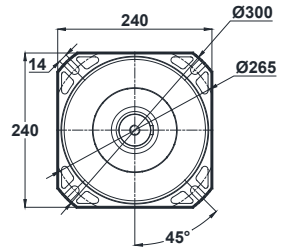
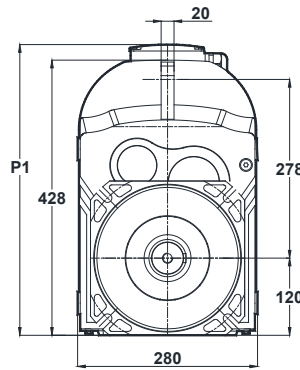
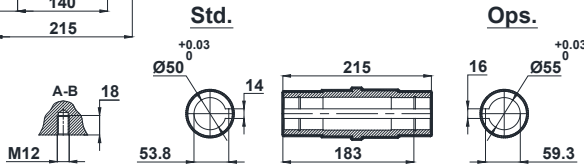
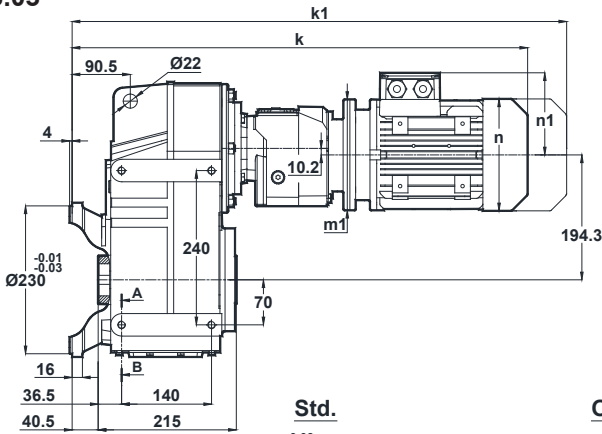

Klemens Pozisyonları  
Terminal Box Positions  
Klemmenkasten Positionen

Opsiyonel Flaş Ölçüleri  
Optional Flange Dimensions  
Auswählbare Flanschabmessungen

	63/B5 63/B14	71/B5 71/B14
k	635	654
k1	696	745
n / n1	121 / 97	137 / 112
m1 (B5)	140	160
m1 (B14)	90	105
p1	-	-

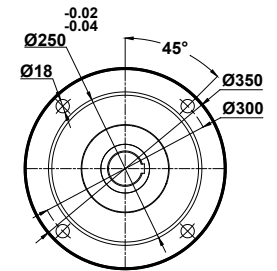
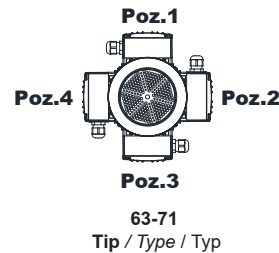

63-71  
Tip / Type / Typ

Diğer opsiyonel flaş ölçüleri için sayfa 326'ya bakınız.  
Please see on page 326 for other optional flange dimensions  
Siehe Seite 326 für andere auswählbare Flanschabmessungen

"k1" ölçüsü frenli redüktörlere aittir.  
Dimensions "k1" is for motors with brake.  
Maße "k1" ist für Bremsenmotoren.

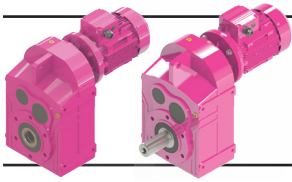

# Ölçü Sayfaları Dimension Pages Abmessungsseiten

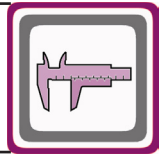

Mil ucu çektirme deliği DIN 332 sayfa 2 / Tapped center hole according to DIN 332, sheet 2 / Zentrierung mit Gewinde nach DIN 332, Blatt 2

DV572.00  
DV573.00

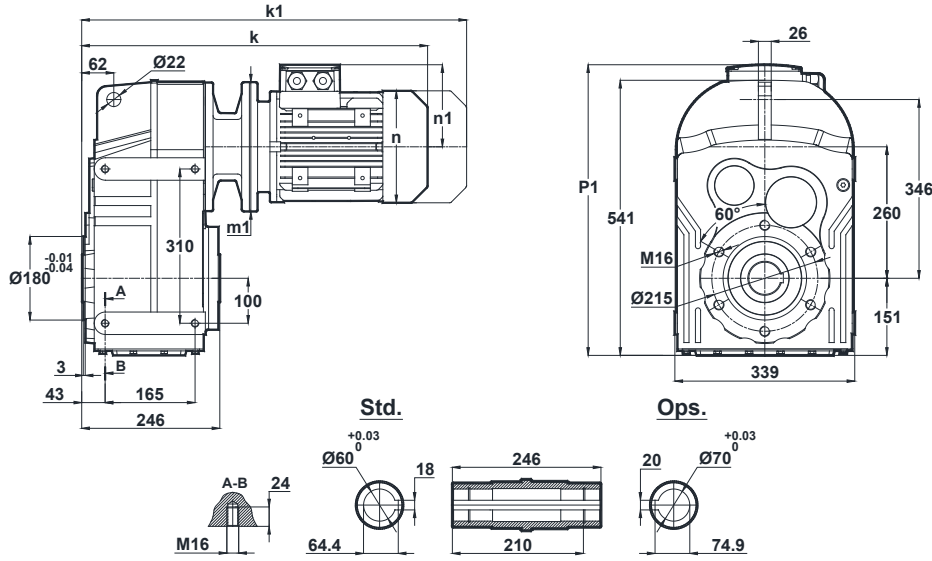

Klemens Pozisyonları  
Terminal Box Positions  
Klemmenkasten Positionen

	80/B5	90S/B5 90S/B14	90L/B5 90L/B14	100L/B5 100L/B14	112M/B5 112M/B14	132S/B5 132S/B14	132M/B5 132M/B14	160M/B5	160L/B5	180M/B5	180L/B5
k	511	552	552	606	626	729	729	888	888	977	977
k1	604	656.5	656.5	725.5	730.5	859	859	1068	1068	1084.5	1084.5
n / n1	155 / 121	176 / 132	176 / 132	193 / 147	215 / 158	257 / 179	257 / 179	315 / 219	315 / 219	347 / 234	347 / 234
m1 (B5)	200	200	200	250	250	300	300	350	350	350	350
m1 (B14)	-	140	140	160	160	200	200	-	-	-	-
p1	-	543	543	558	569	590	590	636	636	655	655

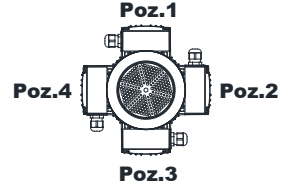

80-90-100-112-132-160-180  
Tip / Type / Typ

DV572.01  
DV573.01

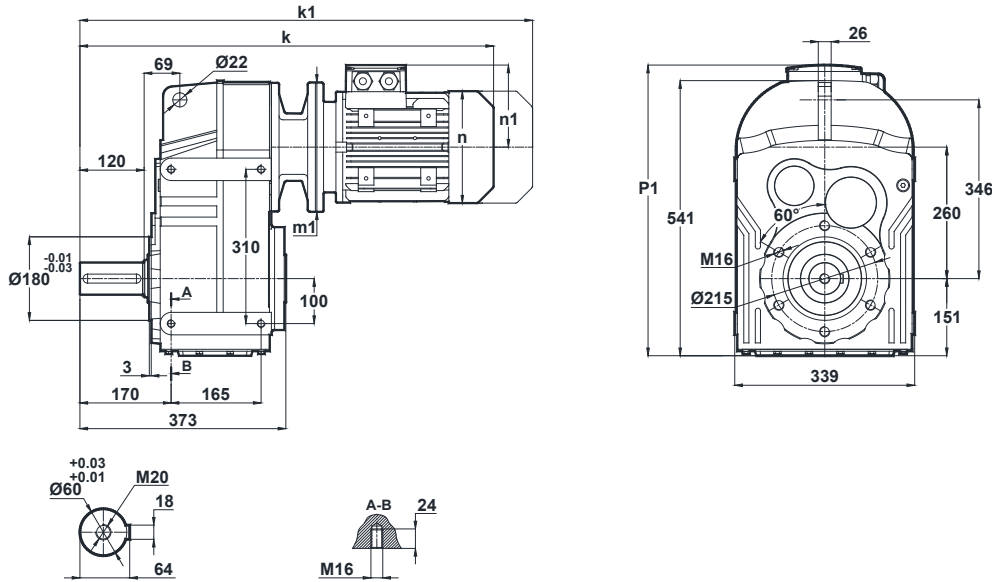

Klemens Pozisyonları  
Terminal Box Positions  
Klemmenkasten Positionen

	80/B5	90S/B5 90S/B14	90L/B5 90L/B14	100L/B5 100L/B14	112M/B5 112M/B14	132S/B5 132S/B14	132M/B5 132M/B14	160M/B5	160L/B5	180M/B5	180L/B5
k	638	679	679	733	753	856	856	1015	1015	1104	1104
k1	731	783.5	783.5	852.5	857.5	986	986	1195	1195	1274.5	1274.5
n / n1	155 / 121	176 / 132	176 / 132	193 / 147	215 / 158	257 / 179	257 / 179	315 / 219	315 / 219	347 / 234	347 / 234
m1 (B5)	200	200	200	250	250	300	300	350	350	350	350
m1 (B14)	-	140	140	160	160	200	200	-	-	-	-
p1	-	543	543	558	569	590	590	636	636	655	655

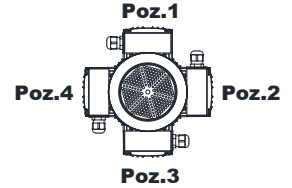

80-90-100-112-132-160-180  
Tip / Type / Typ

"k1" ölçüsü frenli redüktörlere aittir.  
Dimensions "k1" is for motors with brake.  
Maße "k1" ist für Bremsenmotoren.

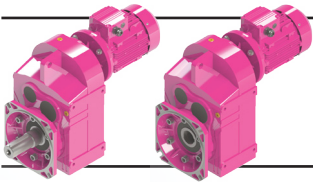

# Ölçü Sayfaları Dimension Pages Abmessungsseiten

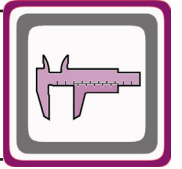

Mil ucu çektirme deliği DIN 332 sayfa 2 / Tapped center hole according to DIN 332, sheet 2 / Zentrierung mit Gewinde nach DIN 332, Blatt 2

DV572.02  
DV573.02

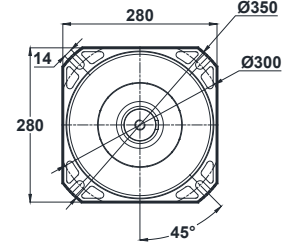
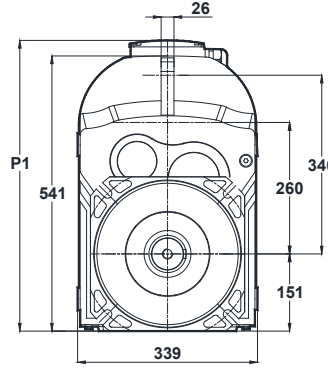
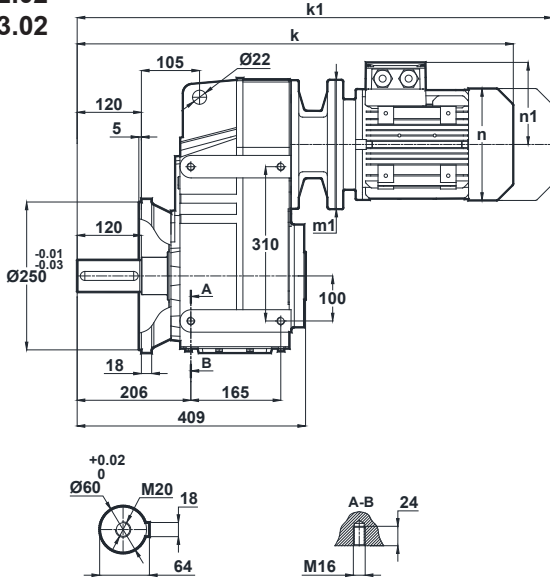

Klemens Pozisyonları  
Terminal Box Positions  
Klemmenkasten Positionen

Opsiyonel Flanş Ölçüleri  
Optional Flange Dimensions  
Auswählbare Flanschabmessungen

	80/B5	90S/B5 90S/B14	90L/B5 90L/B14	100L/B5 100L/B14	112M/B5 112M/B14	132S/B5 132S/B14	132M/B5 132M/B14	160M/B5	160L/B5	180M/B5	180L/B5
k	674	715	715	769	789	892	892	1051	1051	1140	1140
k1	767	819.5	819.5	888.5	893.5	1022	1022	1231	1231	1310.5	1310.5
n / n1	155 / 121	176 / 132	176 / 132	193 / 147	215 / 158	257 / 179	257 / 179	315 / 219	315 / 219	347 / 234	347 / 234
m1 (B5)	200	200	200	250	250	300	300	350	350	350	350
m1 (B14)	-	140	140	160	160	200	200	-	-	-	-
p1	-	543	543	558	569	590	590	636	636	655	655

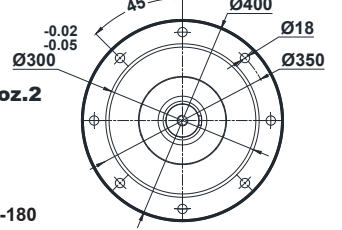
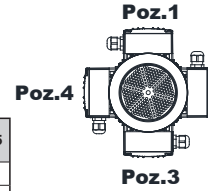

80-90-100-112-132-160-180  
Tip / Type / Typ

Diğer opsiyonel flanş ölçüleri için sayfa 326'ya bakınız.  
Please see on page 326 for other optional flange dimensions  
Siehe Seite 326 für andere auswählbare Flanschabmessungen

DV572.03  
DV573.03

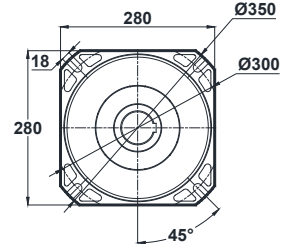
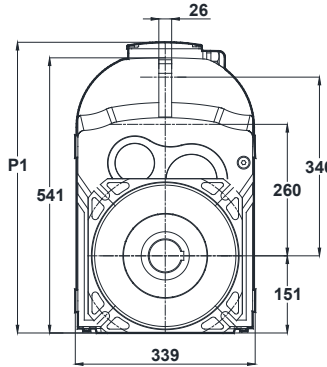
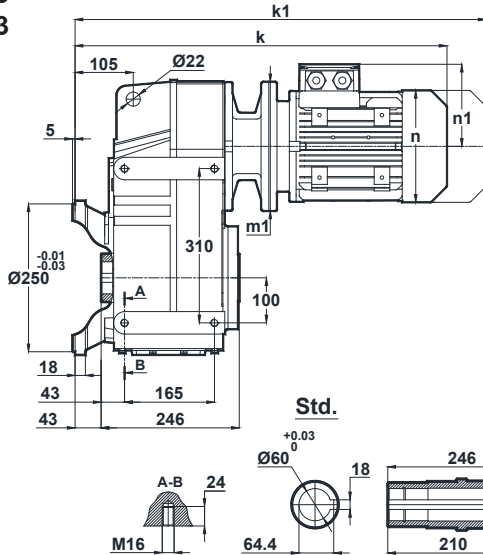

Klemens Pozisyonları  
Terminal Box Positions  
Klemmenkasten Positionen

Opsiyonel Flanş Ölçüleri  
Optional Flange Dimensions  
Auswählbare Flanschabmessungen

	80/B5	90S/B5 90S/B14	90L/B5 90L/B14	100L/B5 100L/B14	112M/B5 112M/B14	132S/B5 132S/B14	132M/B5 132M/B14	160M/B5	160L/B5	180M/B5	180L/B5
k	554	595	595	649	669	772	772	931	931	1020	1020
k1	647	699.5	699.5	768.5	773.5	902	902	1111	1111	1190.5	1190.5
n / n1	155 / 121	176 / 132	176 / 132	193 / 147	215 / 158	257 / 179	257 / 179	315 / 219	315 / 219	347 / 234	347 / 234
m1 (B5)	200	200	200	250	250	300	300	350	350	350	350
m1 (B14)	-	140	140	160	160	200	200	-	-	-	-
p1	-	543	543	558	569	590	590	636	636	655	655

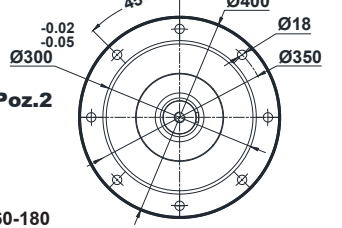
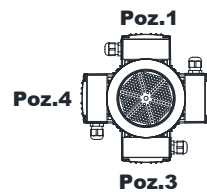

80-90-100-112-132-160-180  
Tip / Type / Typ

Diğer opsiyonel flanş ölçüleri için sayfa 326'ya bakınız.  
Please see on page 326 for other optional flange dimensions  
Siehe Seite 326 für andere auswählbare Flanschabmessungen

"k1" ölçüsü frenli redüktörlere aittir.  
Dimensions "k1" is for motors with brake.  
Maße "k1" ist für Bremsenmotoren.

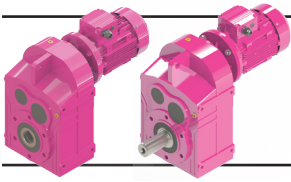

# Ölçü Sayfaları

## Dimension Pages

### Abmessungsseiten

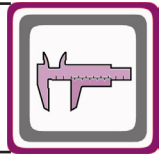

Mil ucu çektirme deliği DIN 332 sayfa 2 / Tapped center hole according to DIN 332, sheet 2 / Zentrierung mit Gewinde nach DIN 332, Blatt 2

#### DV574.00

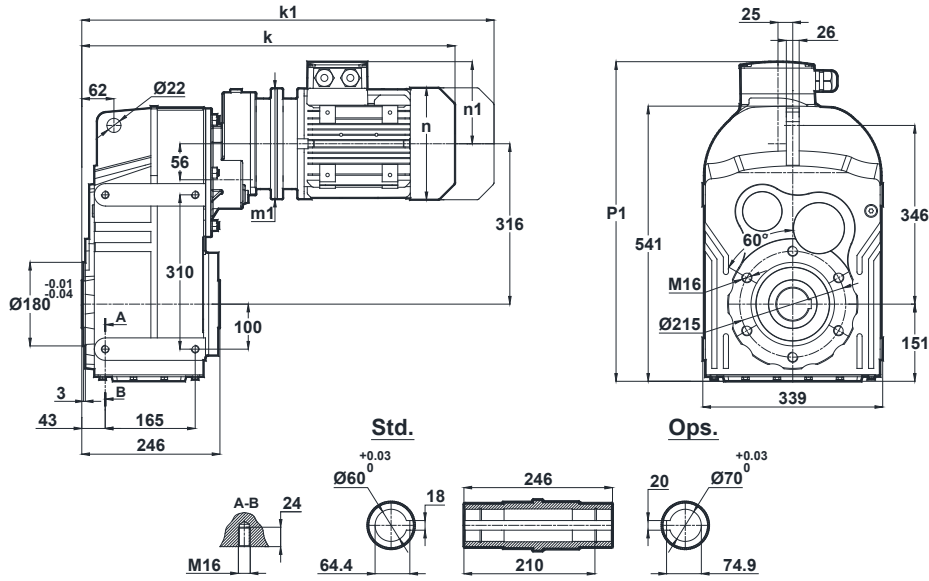

	71/B5	80/B5 80/B14	90S/B5 90S/B14	90L/B5 90L/B14
k	586	609	650	650
k1	677	702	754.5	754.5
n / n1	137 / 112	155 / 121	176 / 132	176 / 132
m1 (B5)	160	200	200	200
m1 (B14)	-	120	140	140
p1	579	588	599	599

Klemens Pozisyonları  
Terminal Box Positions  
Klemmenkasten Positionen

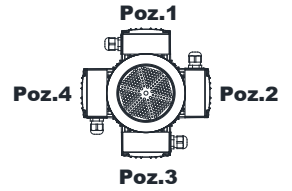

71-80-90  
Tip / Type / Typ

#### DV574.01

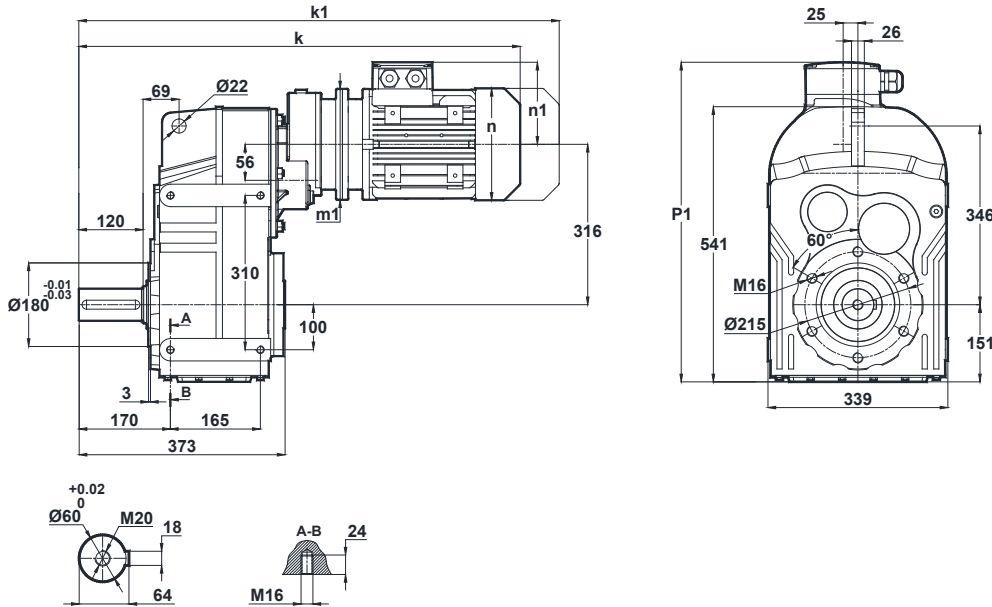

	71/B5	80/B5 80/B14	90S/B5 90S/B14	90L/B5 90L/B14
k	713	736	777	777
k1	804	829	881.5	881.5
n / n1	137 / 112	155 / 121	176 / 132	176 / 132
m1 (B5)	160	200	200	200
m1 (B14)	-	120	140	140
p1	579	588	599	599

Klemens Pozisyonları  
Terminal Box Positions  
Klemmenkasten Positionen

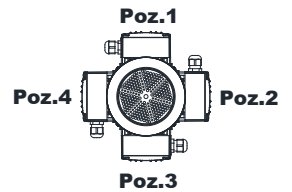

71-80-90  
Tip / Type / Typ

"k1" ölçüsü frenli redüktörlere aittir.  
Dimensions "k1" is for motors with brake.  
Maße "k1" ist für Bremsenmotoren.

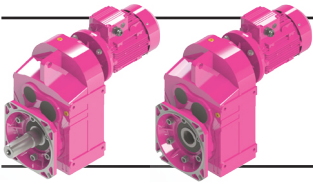

# Ölçü Sayfaları Dimension Pages Abmessungsseiten

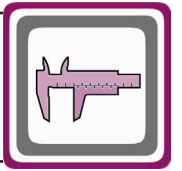

Mil ucu çektirme deliği DIN 332 sayfa 2 / Tapped center hole according to DIN 332, sheet 2 / Zentrierung mit Gewinde nach DIN 332, Blatt 2

## DV574.02

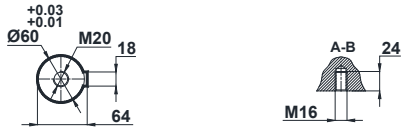
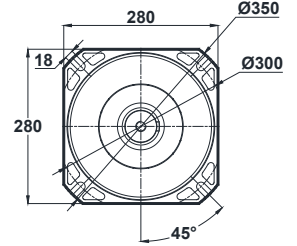
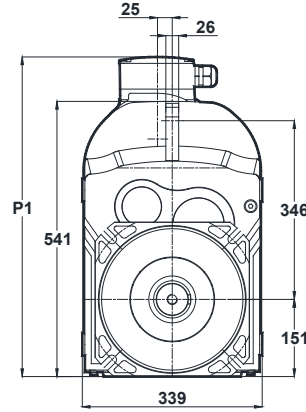
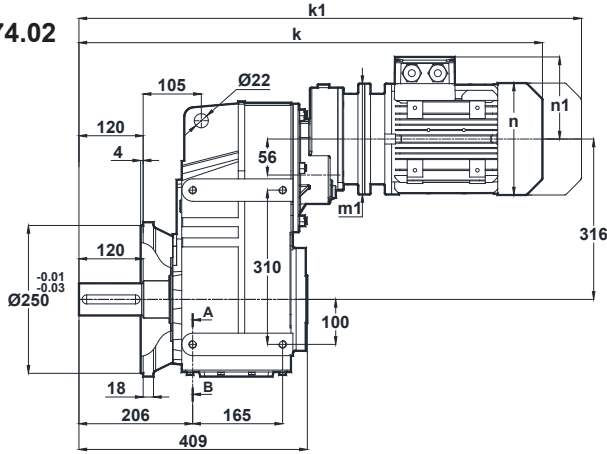

Klemens Pozisyonları  
Terminal Box Positions  
Klemmenkasten Positionen

Opsiyonel Flaş Ölçüleri  
Optional Flange Dimensions  
Auswählbare Flanschabmessungen

	71/B5	80/B5 80/B14	90S/B5 90S/B14	90L/B5 90L/B14
k	749	772	813	813
k1	840	865	917.5	917.5
n / n1	137 / 112	155 / 121	176 / 132	176 / 132
m1 (B5)	160	200	200	200
m1 (B14)	-	120	140	140
p1	579	588	599	599

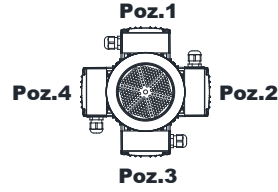

71-80-90  
Tip / Type / Typ

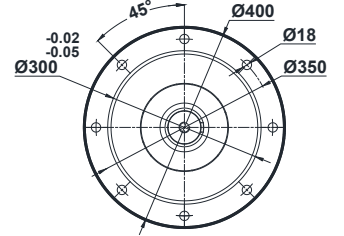

Diğer opsiyonel flaş ölçüleri için sayfa 326'ya bakınız.  
Please see on page 326 for other optional flange dimensions  
Siehe Seite 326 für andere auswählbare Flanschabmessungen

## DV574.03

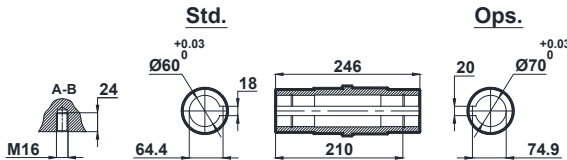
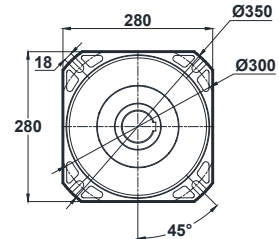
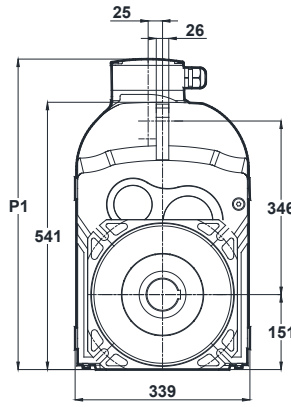
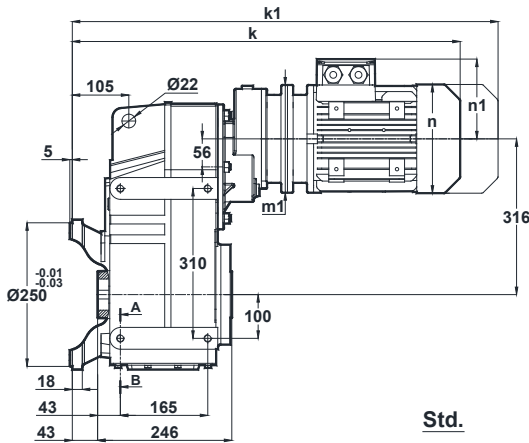

Klemens Pozisyonları  
Terminal Box Positions  
Klemmenkasten Positionen

Opsiyonel Flaş Ölçüleri  
Optional Flange Dimensions  
Auswählbare Flanschabmessungen

	71/B5	80/B5 80/B14	90S/B5 90S/B14	90L/B5 90L/B14
k	629	652	693	693
k1	720	745	797.5	797.5
n / n1	137 / 112	155 / 121	176 / 132	176 / 132
m1 (B5)	160	200	200	200
m1 (B14)	-	120	140	140
p1	579	588	599	599

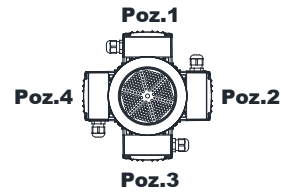

71-80-90  
Tip / Type / Typ

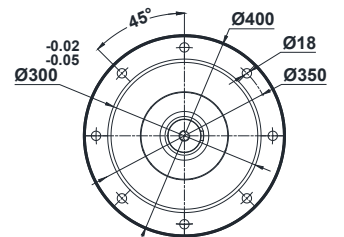

Diğer opsiyonel flaş ölçüleri için sayfa 326'ya bakınız.  
Please see on page 326 for other optional flange dimensions  
Siehe Seite 326 für andere auswählbare Flanschabmessungen

"k1" ölçüsü frenli redüktörlere aittir.  
Dimensions "k1" is for motors with brake.  
Maße "k1" ist für Bremsenmotoren.

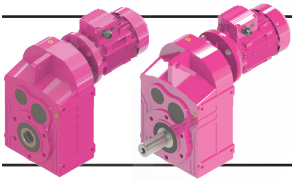

# Ölçü Sayfaları

## Dimension Pages

### Abmessungsseiten

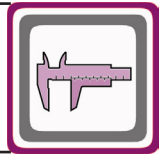

Mil ucu çektirme deliği DIN 332 sayfa 2 / Tapped center hole according to DIN 332, sheet 2 / Zentrierung mit Gewinde nach DIN 332, Blatt 2

DV575.00  
DV576.00

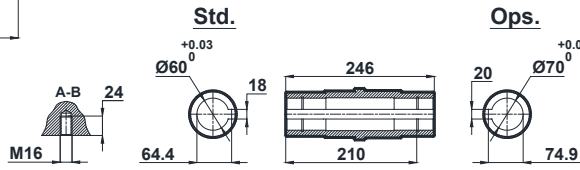
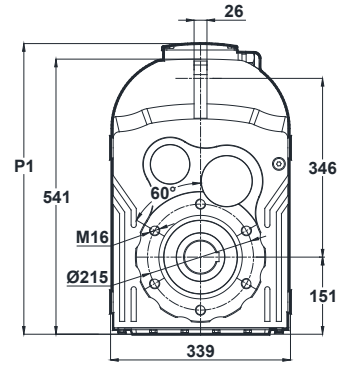
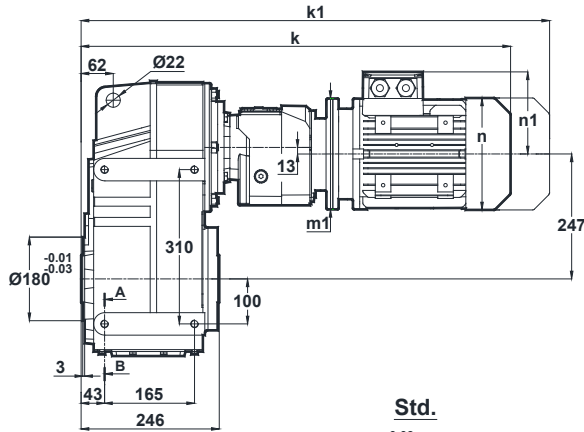

Klemens Pozisyonları  
Terminal Box Positions  
Klemmenkasten Positionen

	63/B5	71/B5 71/B14
k	696	685
k1	757	776
n / n1	121 / 97	137 / 112
m1 (B5)	140	160
m1 (B14)	-	105
p1	-	-

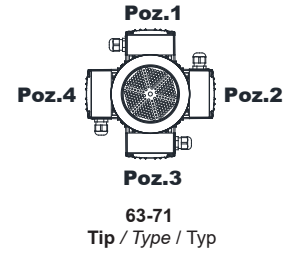

DV575.01  
DV576.01

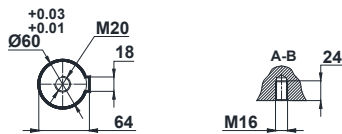
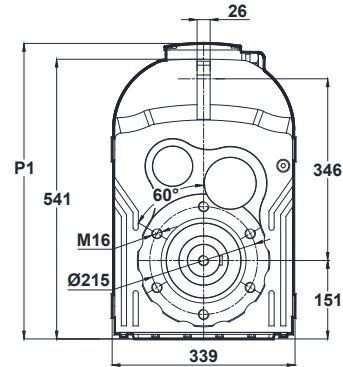
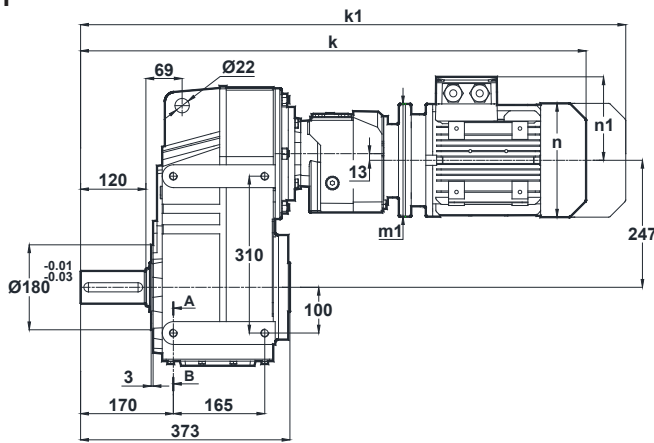

Klemens Pozisyonları  
Terminal Box Positions  
Klemmenkasten Positionen

	63/B5	71/B5 71/B14
k	823	812
k1	884	903
n / n1	121 / 97	137 / 112
m1 (B5)	140	160
m1 (B14)	-	105
p1	-	-

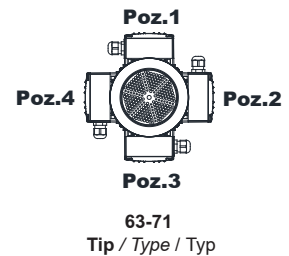

"k1" ölçüsü frenli redüktörlere aittir.  
Dimensions "k1" is for motors with brake.  
Maße "k1" ist für Bremsenmotoren.

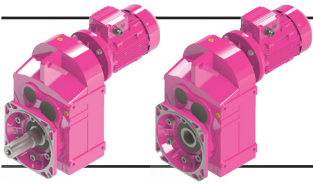

# Ölçü Sayfaları Dimension Pages Abmessungsseiten

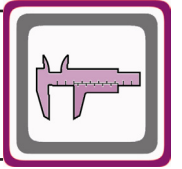

Mil ucu çektirme deliği DIN 332 sayfa 2 / Tapped center hole according to DIN 332, sheet 2 / Zentrierung mit Gewinde nach DIN 332, Blatt 2

DV575.02  
DV576.02

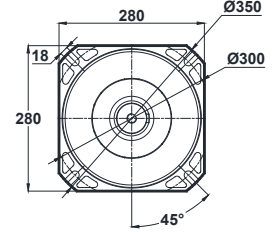
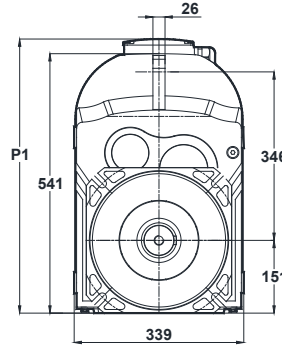
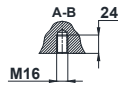
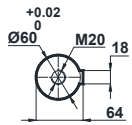
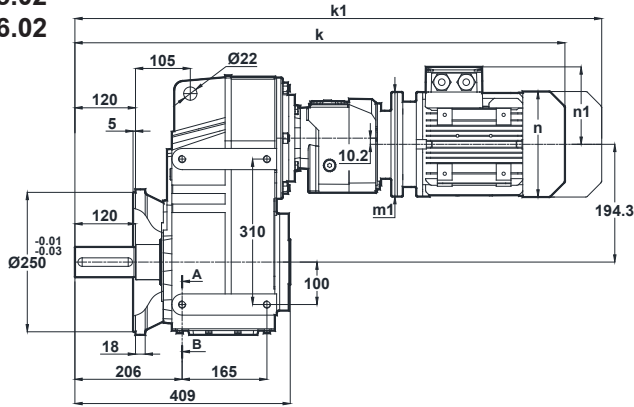

Klemens Pozisyonları  
Terminal Box Positions  
Klemmenkasten Positionen

Opsiyonel Flanş Ölçüleri  
Optional Flange Dimensions  
Auswählbare Flanschabmessungen

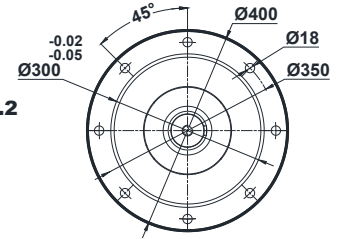
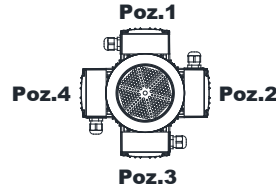

	63/B5	71/B5 71/B14
k	859	848
k1	920	939
n / n1	121 / 97	137 / 112
m1 (B5)	140	160
m1 (B14)	-	105
p1	-	-

63-71

Tip / Type / Typ

Diğer opsiyonel flanş ölçüleri için sayfa 326'ya bakınız.  
Please see on page 326 for other optional flange dimensions  
Siehe Seite 326 für andere auswählbare Flanschabmessungen

DV575.03  
DV576.03

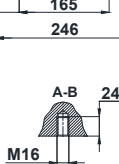
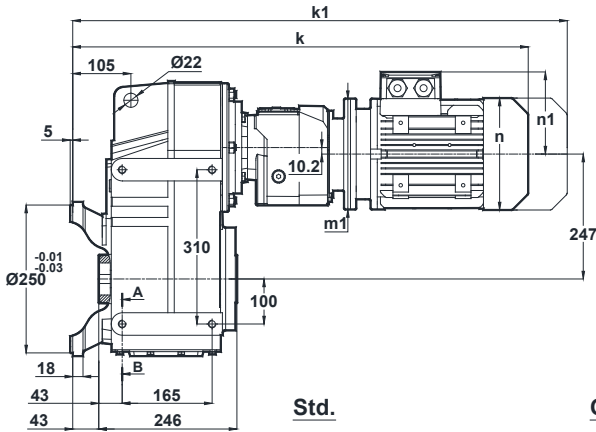

Std.

Ops.

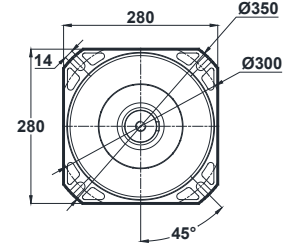
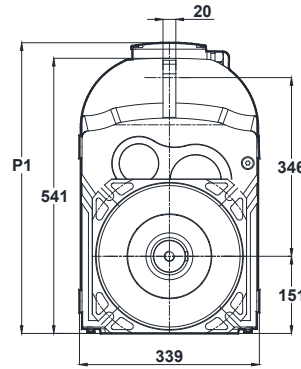
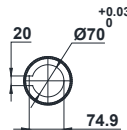

Klemens Pozisyonları  
Terminal Box Positions  
Klemmenkasten Positionen

Opsiyonel Flanş Ölçüleri  
Optional Flange Dimensions  
Auswählbare Flanschabmessungen

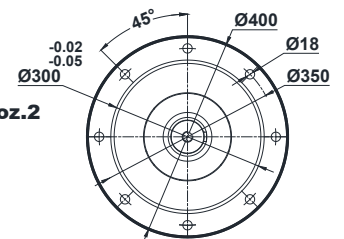
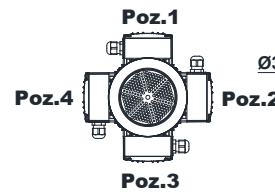

	63/B5	71/B5 71/B14
k	739	728
k1	800	819
n / n1	121 / 97	137 / 112
m1 (B5)	140	160
m1 (B14)	-	105
p1	-	-

63-71

Tip / Type / Typ

Diğer opsiyonel flanş ölçüleri için sayfa 326'ya bakınız.  
Please see on page 326 for other optional flange dimensions  
Siehe Seite 326 für andere auswählbare Flanschabmessungen

"k1" ölçüsü frenli redüktörlere aittir.  
Dimensions "k1" is for motors with brake.  
Maße "k1" ist für Bremsenmotoren.

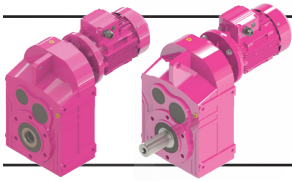

# Ölçü Sayfaları

## Dimension Pages

### Abmessungsseiten

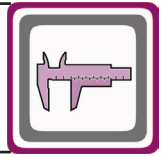

Mil ucu çektirme deliği DIN 332 sayfa 2 / Tapped center hole according to DIN 332, sheet 2 / Zentrierung mit Gewinde nach DIN 332, Blatt 2

DV672.00  
DV673.00

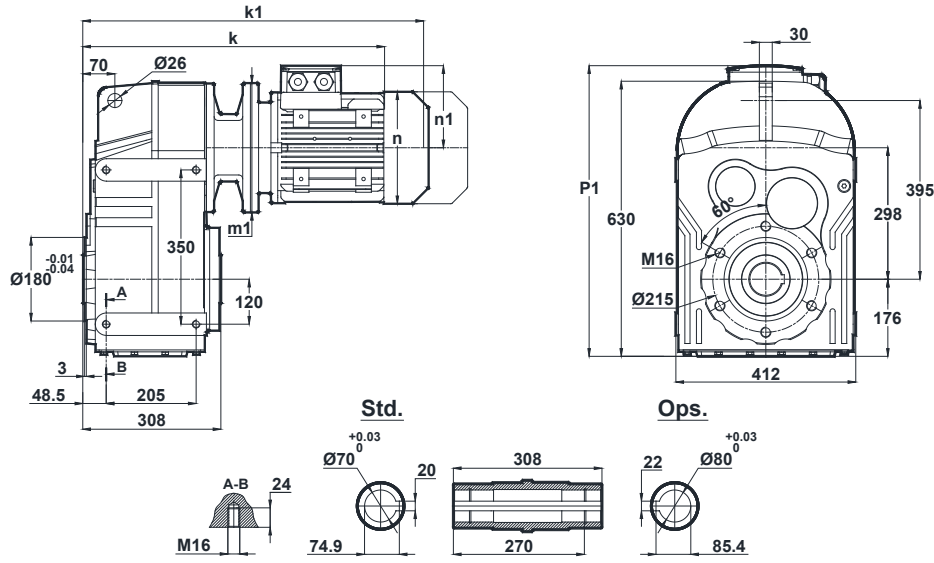

	100L/B5	112M/B5	132S/B5 132S/B14	132M/B5 132M/B14	160M/B5	160L/B5	180M/B5	180L/B5	200L/B5
k	658	679	784	784	939	939	1028	1028	1086
k1	777.5	783.5	914	914	1119	1119	1198.5	1198.5	1272.5
n / n1	193 / 147	215 / 158	257 / 179	257 / 179	315 / 219	315 / 219	347 / 234	347 / 234	390 / 275
m1 (B5)	250	250	300	300	350	350	350	350	400
m1 (B14)	-	-	200	200	-	-	-	-	-
p1	-	632	653	653	699	699	718	718	749

Klemens Pozisyonları  
Terminal Box Positions  
Klemmenkasten Positionen

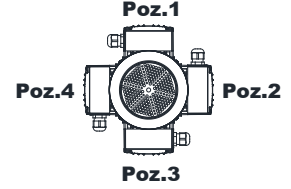

100-112-132-160-180-200  
Tip / Type / Typ

DV672.01  
DV673.01

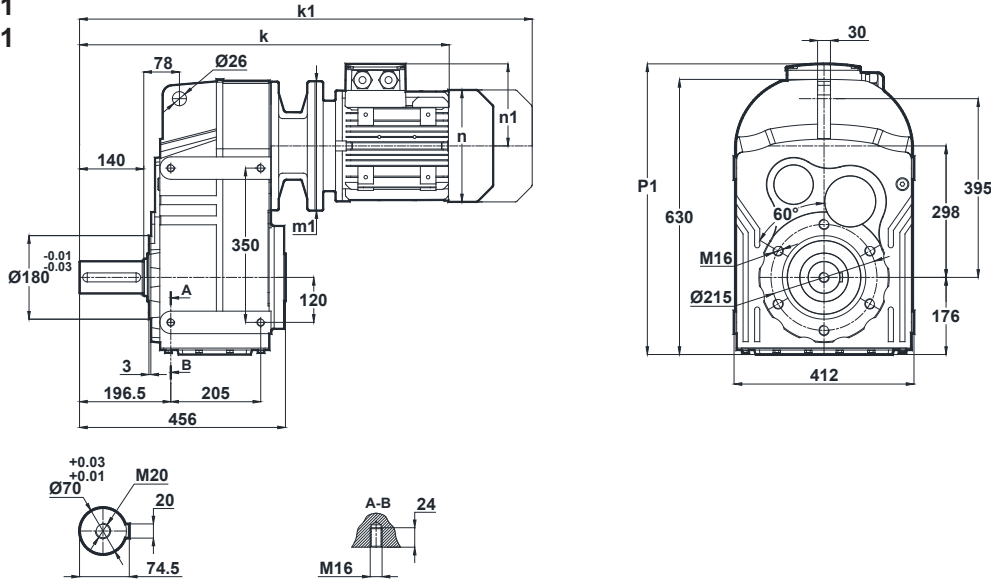

	100L/B5	112M/B5	132S/B5 132S/B14	132M/B5 132M/B14	160M/B5	160L/B5	180M/B5	180L/B5	200L/B5
k	806	827	932	932	1087	1087	1176	1176	1234
k1	925.5	931.5	1062	1062	1267	1267	1346.5	1346.5	1420.5
n / n1	193 / 147	215 / 158	257 / 179	257 / 179	315 / 219	315 / 219	347 / 234	347 / 234	390 / 275
m1 (B5)	250	250	300	300	350	350	350	350	400
m1 (B14)	-	-	200	200	-	-	-	-	-
p1	-	632	653	653	699	699	718	718	749

Klemens Pozisyonları  
Terminal Box Positions  
Klemmenkasten Positionen

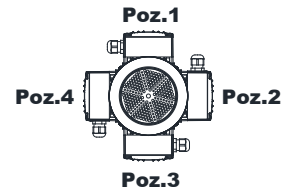

100-112-132-160-180-200  
Tip / Type / Typ

"k1" ölçüsü frenli redüktörlere aittir.  
Dimensions "k1" is for motors with brake.  
Maße "k1" ist für Bremsenmotoren.

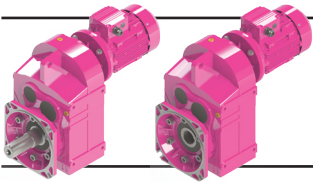

# Ölçü Sayfaları Dimension Pages Abmessungsseiten

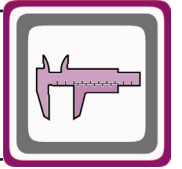

Mil ucu çektirme deliği DIN 332 sayfa 2 / Tapped center hole according to DIN 332, sheet 2 / Zentrierung mit Gewinde nach DIN 332, Blatt 2

DV672.02  
DV673.02

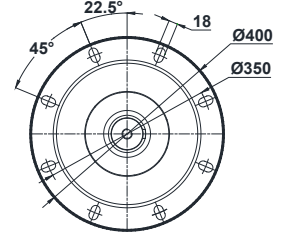
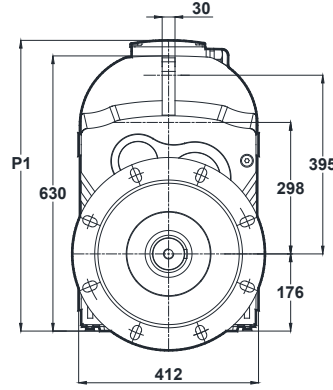
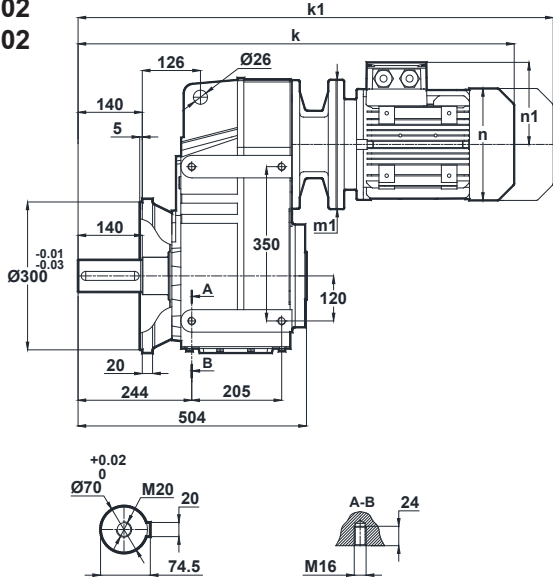

Klemens Pozisyonları  
Terminal Box Positions  
Klemmenkasten Positionen

Opsiyonel Flanş Ölçüleri  
Optional Flange Dimensions  
Auswählbare Flanschabmessungen

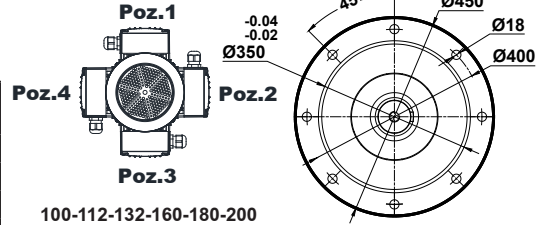

100-112-132-160-180-200  
Tip / Type / Typ

Diğer opsiyonel flanş ölçüleri için sayfa 326'ya bakınız.  
Please see on page 326 for other optional flange dimensions  
Siehe Seite 326 für andere auswählbare Flanschabmessungen

	100L/B5	112M/B5	132S/B5 132S/B14	132M/B5 132M/B14	160M/B5	160L/B5	180M/B5	180L/B5	200L/B5
k	854	875	980	980	1135	1135	1224	1224	1282
k1	973.5	979.5	1110	1110	1315	1315	1394.5	1394.5	1468.5
n / n1	193 / 147	215 / 158	257 / 179	257 / 179	315 / 219	315 / 219	347 / 234	347 / 234	390 / 275
m1 (B5)	250	250	300	300	350	350	350	350	400
m1 (B14)	-	-	200	200	-	-	-	-	-
p1	-	632	653	653	699	699	718	718	749

DV672.03  
DV673.03

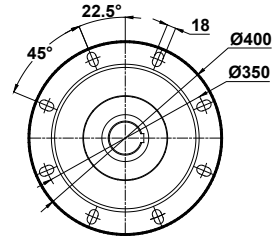
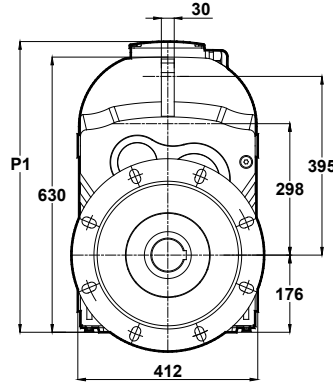
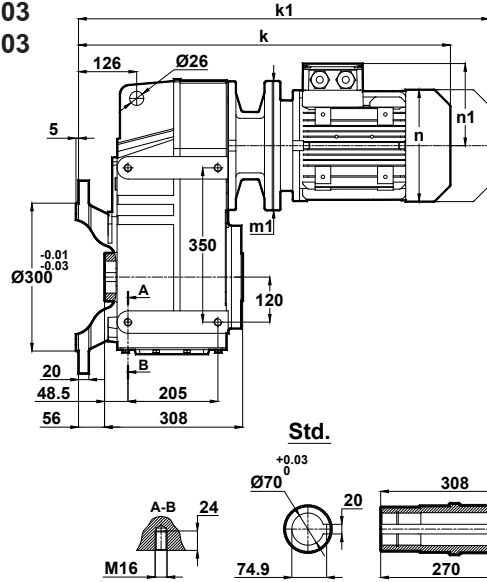

Klemens Pozisyonları  
Terminal Box Positions  
Klemmenkasten Positionen

Opsiyonel Flanş Ölçüleri  
Optional Flange Dimensions  
Auswählbare Flanschabmessungen

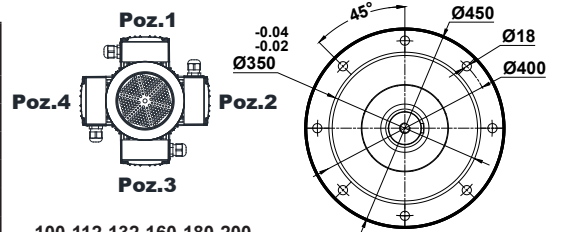

100-112-132-160-180-200  
Tip / Type / Typ

Diğer opsiyonel flanş ölçüleri için sayfa 326'ya bakınız.  
Please see on page 326 for other optional flange dimensions  
Siehe Seite 326 für andere auswählbare Flanschabmessungen

	100L/B5	112M/B5	132S/B5 132S/B14	132M/B5 132M/B14	160M/B5	160L/B5	180M/B5	180L/B5	200L/B5
k	714	735	840	840	995	995	1084	1084	1142
k1	833.5	839.5	970	970	1175	1175	1254.5	1254.5	1328.5
n / n1	193 / 147	215 / 158	257 / 179	257 / 179	315 / 219	315 / 219	347 / 234	347 / 234	390 / 275
m1 (B5)	250	250	300	300	350	350	350	350	400
m1 (B14)	-	-	200	200	-	-	-	-	-
p1	-	632	653	653	699	699	718	718	749

"k1" ölçüsü frenli redüktörlere aittir.  
Dimensions "k1" is for motors with brake.  
Maße "k1" ist für Bremsenmotoren.

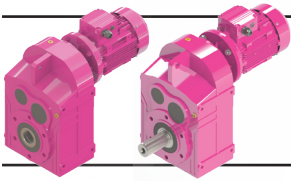

# Ölçü Sayfaları

## Dimension Pages

### Abmessungsseiten

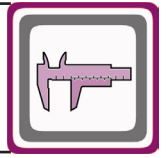

Mil ucu çektirme deliği DIN 332 sayfa 2 / Tapped center hole according to DIN 332, sheet 2 / Zentrierung mit Gewinde nach DIN 332, Blatt 2

#### DV674.00

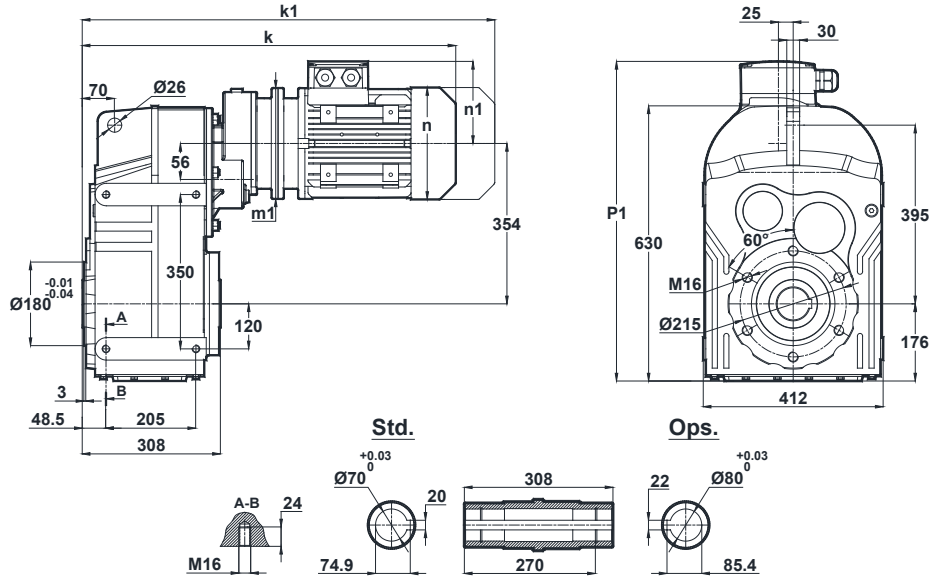

Klemens Pozisyonları  
Terminal Box Positions  
Klemmenkasten Positionen

	71/B5	80/B5 80/B14	90S/B5 90S/B14	90L/B5 90L/B14
k	639	662	703	703
k1	730	755	807.5	807.5
n / n1	137 / 112	155 / 121	176 / 132	176 / 132
m1 (B5)	160	200	200	200
m1 (B14)	-	120	140	140
p1	642	651	662	662

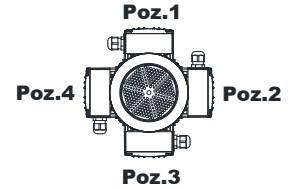

71-80-90  
Tip / Type / Typ

#### DV674.01

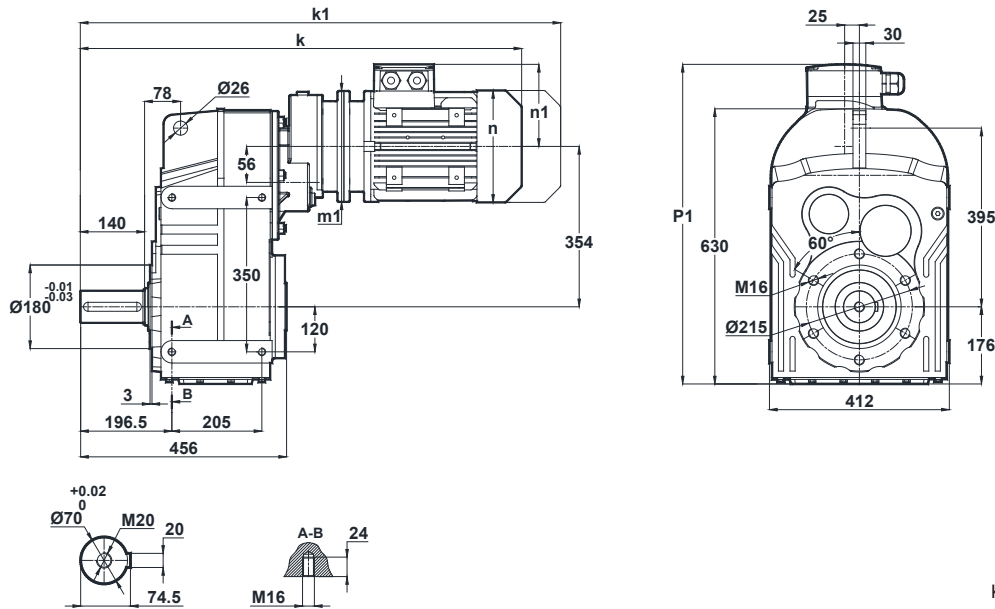

Klemens Pozisyonları  
Terminal Box Positions  
Klemmenkasten Positionen

	71/B5	80/B5 80/B14	90S/B5 90S/B14	90L/B5 90L/B14
k	787	810	851	851
k1	878	903	955.5	955.5
n / n1	137 / 112	155 / 121	176 / 132	176 / 132
m1 (B5)	160	200	200	200
m1 (B14)	-	120	140	140
p1	642	651	662	662

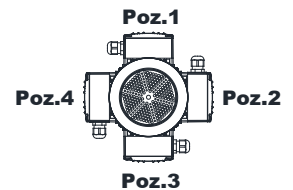

71-80-90  
Tip / Type / Typ

"k1" ölçüsü frenli redüktörlere aittir.  
Dimensions "k1" is for motors with brake.  
Maße "k1" ist für Bremsenmotoren.

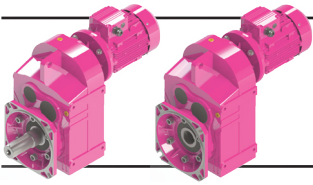

# Ölçü Sayfaları Dimension Pages Abmessungsseiten

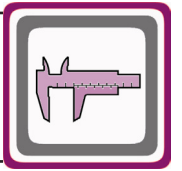

Mil ucu çektirme deliği DIN 332 sayfa 2 / Tapped center hole according to DIN 332, sheet 2 / Zentrierung mit Gewinde nach DIN 332, Blatt 2

## DV674.02

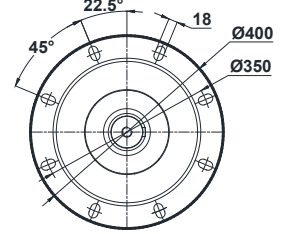
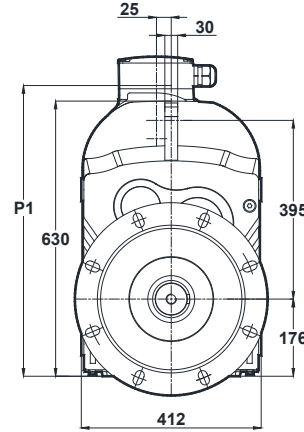
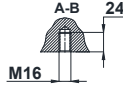
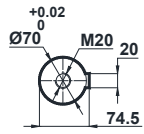
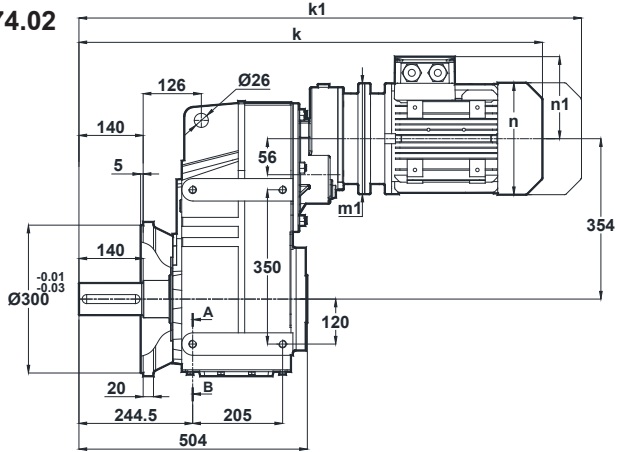

Klemens Pozisyonları  
Terminal Box Positions  
Klemmenkasten Positionen

Opsiyonel Flanş Ölçüleri  
Optional Flange Dimensions  
Auswählbare Flanschabmessungen

	71/B5	80/B5 80/B14	90S/B5 90S/B14	90L/B5 90L/B14
k	835	858	899	899
k1	926	951	1003.5	1003.5
n / n1	137 / 112	155 / 121	176 / 132	176 / 132
m1 (B5)	160	200	200	200
m1 (B14)	-	120	140	140
p1	642	651	662	662

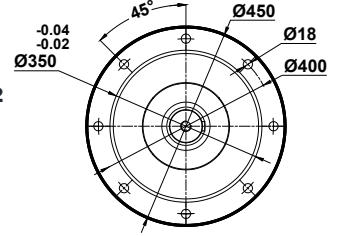
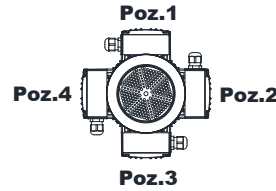

71-80-90  
Tip / Type / Typ

Diğer opsiyonel flanş ölçüleri için sayfa 326'ya bakınız.  
Please see on page 326 for other optional flange dimensions  
Siehe Seite 326 für andere auswählbare Flanschabmessungen

## DV674.03

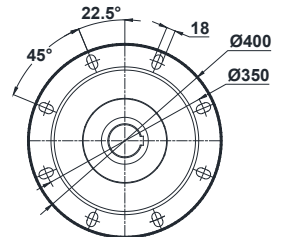
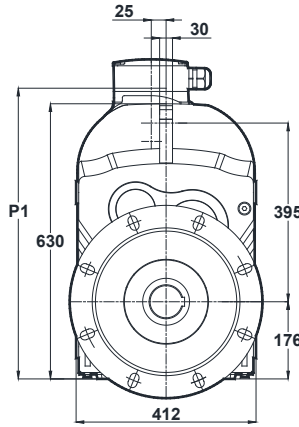
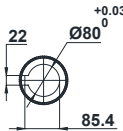
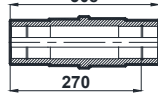
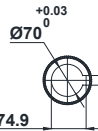
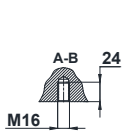
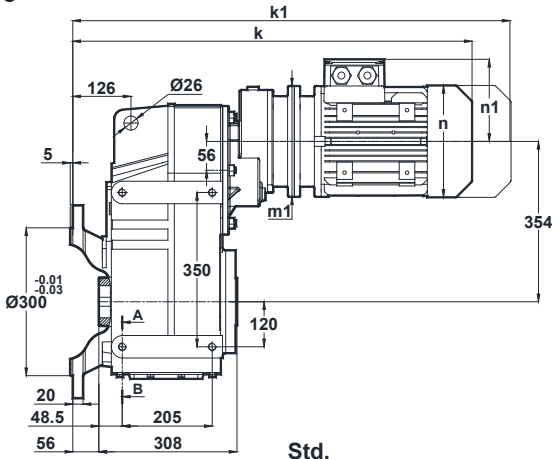

Klemens Pozisyonları  
Terminal Box Positions  
Klemmenkasten Positionen

Opsiyonel Flanş Ölçüleri  
Optional Flange Dimensions  
Auswählbare Flanschabmessungen

	71/B5	80/B5 80/B14	90S/B5 90S/B14	90L/B5 90L/B14
k	695	718	759	759
k1	786	811	863.5	863.5
n / n1	137 / 112	155 / 121	176 / 132	176 / 132
m1 (B5)	160	200	200	200
m1 (B14)	-	120	140	140
p1	642	651	662	662

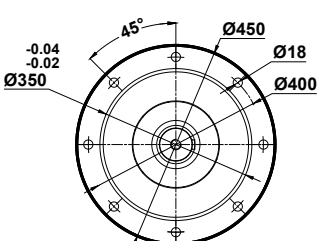
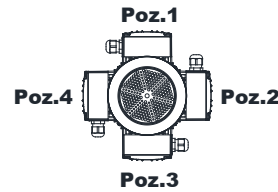

71-80-90  
Tip / Type / Typ

Diğer opsiyonel flanş ölçüleri için sayfa 326'ya bakınız.  
Please see on page 326 for other optional flange dimensions  
Siehe Seite 326 für andere auswählbare Flanschabmessungen

"k1" ölçüsü frenli redüktörlere aittir.  
Dimensions "k1" is for motors with brake.  
Maße "k1" ist für Bremsenmotoren.

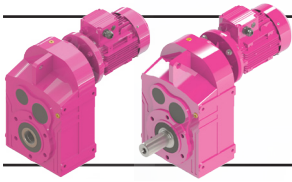

# Ölçü Sayfaları Dimension Pages Abmessungsseiten

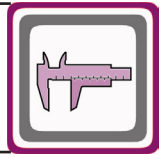

Mil ucu çektirme deliği DIN 332 sayfa 2 / Tapped center hole according to DIN 332, sheet 2 / Zentrierung mit Gewinde nach DIN 332, Blatt 2

DV675.00  
DV676.00

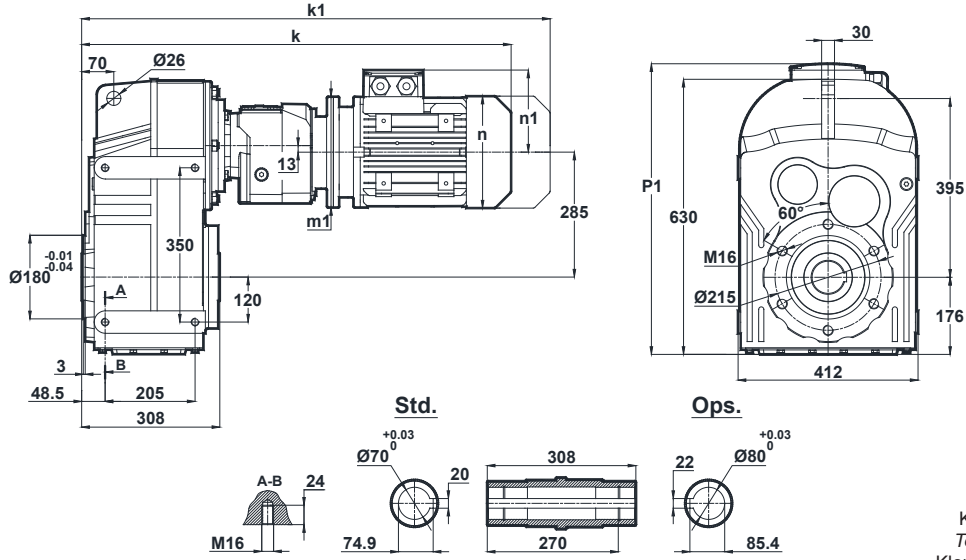

Klemens Pozisyonları  
Terminal Box Positions  
Klemmenkasten Positionen

	63/B5	71/B5 71/B14	80/B5 80/B14
k	751	740	792
k1	812	831	885
n / n1	121 / 97	137 / 112	155 / 121
m1 (B5)	140	160	200
m1 (B14)	-	105	120
p1	-	-	-

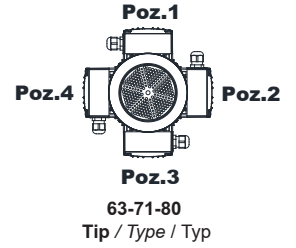

DV675.01  
DV676.01

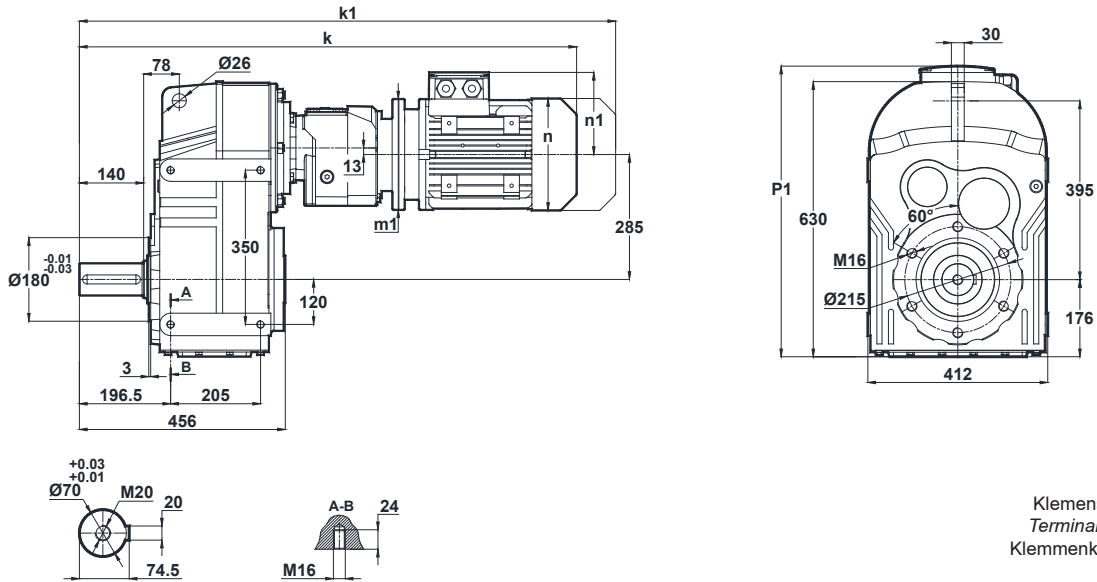

Klemens Pozisyonları  
Terminal Box Positions  
Klemmenkasten Positionen

	63/B5	71/B5 71/B14	80/B5 80/B14
k	899	888	940
k1	960	979	1033
n / n1	121 / 97	137 / 112	155 / 121
m1 (B5)	140	160	200
m1 (B14)	-	105	120
p1	-	-	-

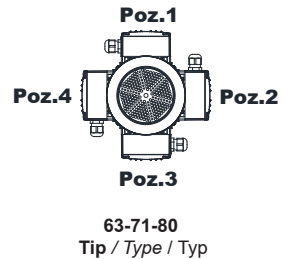

"k1" ölçüsü frenli redüktörlere aittir.  
Dimensions "k1" is for motors with brake.  
Maße "k1" ist für Bremsenmotoren.

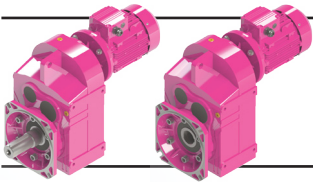

# Ölçü Sayfaları Dimension Pages Abmessungsseiten

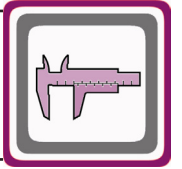

Mil ucu çektirme deliği DIN 332 sayfa 2 / Tapped center hole according to DIN 332, sheet 2 / Zentrierung mit Gewinde nach DIN 332, Blatt 2

DV675.02  
DV676.02

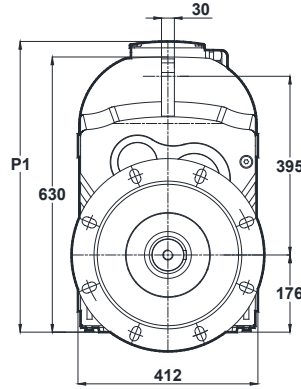
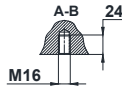
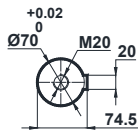
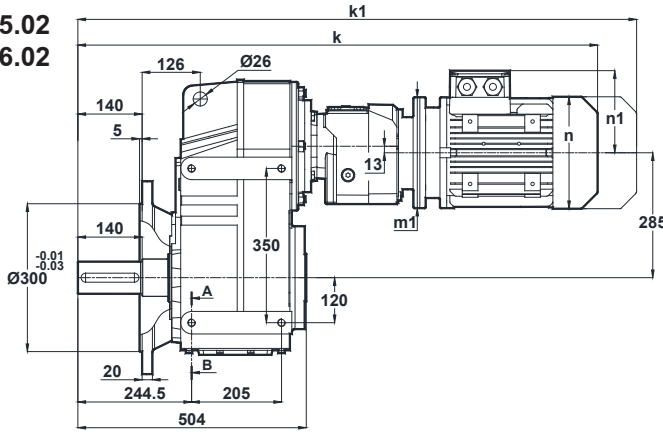

Klemens Pozisyonları  
Terminal Box Positions  
Klemmenkasten Positionen

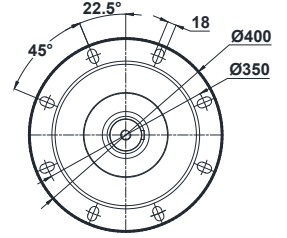

Opsiyonel Flanş Ölçüleri  
Optional Flange Dimensions  
Auswählbare Flanschabmessungen

	63/B5	71/B5 71/B14	80/B5 80/B14
k	947	936	988
k1	1008	1027	1081
n / n1	121 / 97	137 / 112	155 / 121
m1 (B5)	140	160	200
m1 (B14)	-	105	120
p1	-	-	-

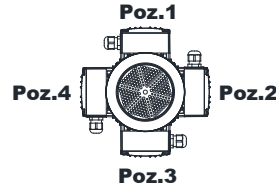

63-71-80  
Tip / Type / Typ

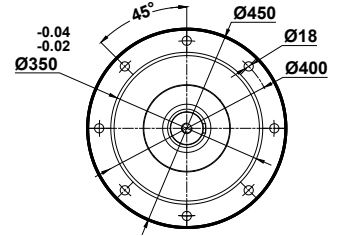

Diğer opsiyonel flanş ölçüleri için sayfa 326'ya bakınız.  
Please see on page 326 for other optional flange dimensions  
Siehe Seite 326 für andere auswählbare Flanschabmessungen

DV675.03  
DV676.03

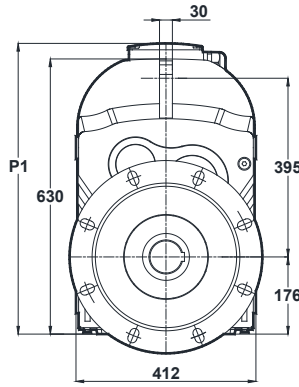
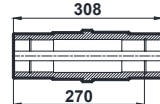
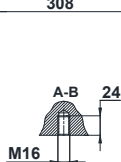
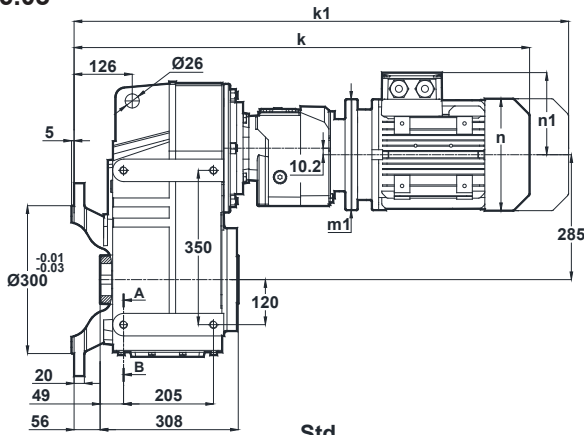

Klemens Pozisyonları  
Terminal Box Positions  
Klemmenkasten Positionen

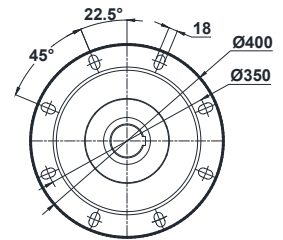

Opsiyonel Flanş Ölçüleri  
Optional Flange Dimensions  
Auswählbare Flanschabmessungen

	63/B5	71/B5 71/B14	80/B5 80/B14
k	807	796	848
k1	868	887	941
n / n1	121 / 97	137 / 112	155 / 121
m1 (B5)	140	160	200
m1 (B14)	-	105	120
p1	-	-	-

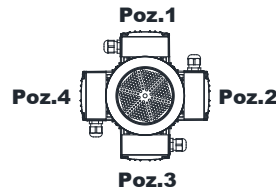

63-71-80  
Tip / Type / Typ

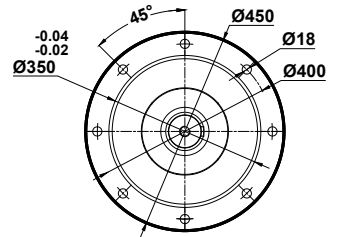

Diğer opsiyonel flanş ölçüleri için sayfa 326'ya bakınız.  
Please see on page 326 for other optional flange dimensions  
Siehe Seite 326 für andere auswählbare Flanschabmessungen

"k1" ölçüsü frenli redüktörlere aittir.  
Dimensions "k1" is for motors with brake.  
Maße "k1" ist für Bremsenmotoren.

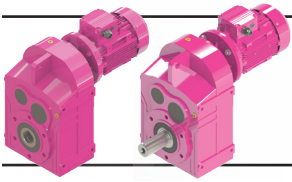

# Ölçü Sayfaları Dimension Pages Abmessungsseiten

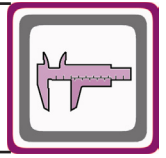

Mil ucu çekirtme deliği DIN 332 sayfa 2 / Tapped center hole according to DIN 332, sheet 2 / Zentrierung mit Gewinde nach DIN 332, Blatt 2

DV772.00  
DV773.00

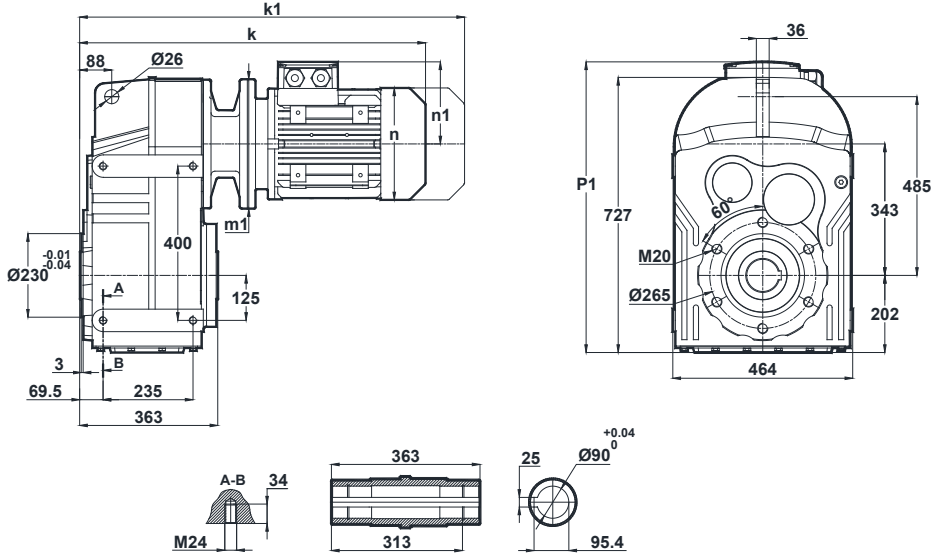

Klemens Pozisyonları  
Terminal Box Positions  
Klemmenkasten Positionen

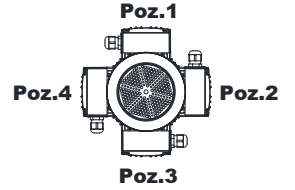

100-112-132-160-180-200-225  
Tip / Type / Typ

	100L/B5	112M/B5	132S/B5 132S/B14	132M/B5 132M/B14	160M/B5	160L/B5	180M/B5	180L/B5	200L/B5	225S/B5	225M/B5
k	700	721	820	820	974	974	1064	1064	1122	1208	1233
k1	819.5	825.5	950	950	1154	1154	1234.5	1234.5	1308.5	1373	1398
n / n1	193 / 147	215 / 158	257 / 179	257 / 179	315 / 219	315 / 219	347 / 234	347 / 234	390 / 275	434 / 285	434 / 285
m1 (B5)	250	250	300	300	350	350	350	350	400	450	450
m1 (B14)	-	-	200	200	-	-	-	-	-	-	-
p1	-	-	724	724	770	770	789	789	822	830	830

DV772.01  
DV773.01

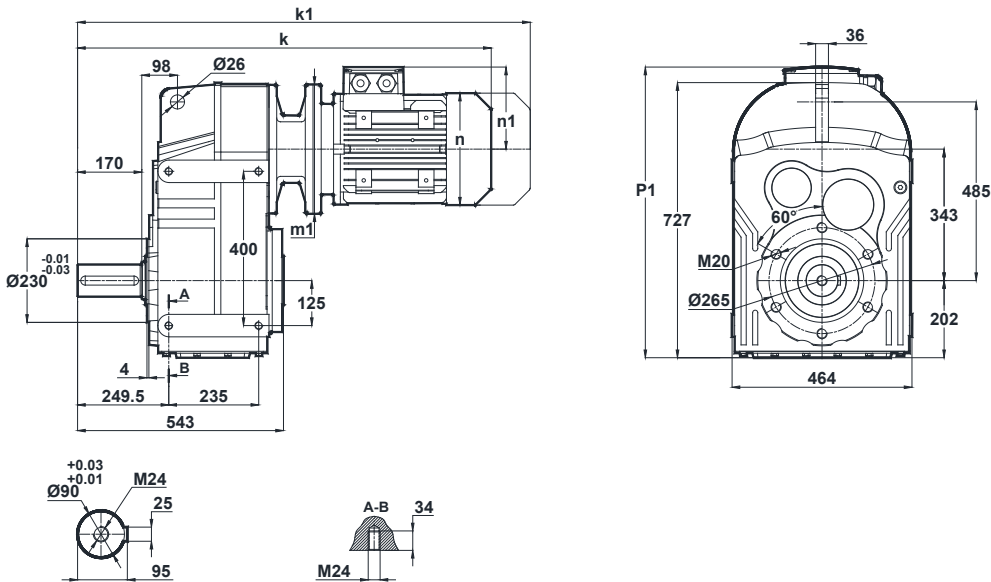

Klemens Pozisyonları  
Terminal Box Positions  
Klemmenkasten Positionen

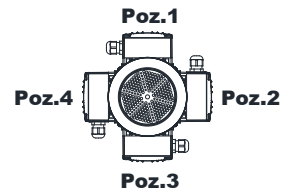

100-112-132-160-180-200-225  
Tip / Type / Typ

	100L/B5	112M/B5	132S/B5 132S/B14	132M/B5 132M/B14	160M/B5	160L/B5	180M/B5	180L/B5	200L/B5	225S/B5	225M/B5
k	880	901	1000	1000	1154	1154	1244	1244	1302	1388	1413
k1	999.5	1005.5	1130	1130	1334	1334	1414.5	1414.5	1488.5	1553	1578
n / n1	193 / 147	215 / 158	257 / 179	257 / 179	315 / 219	315 / 219	347 / 234	347 / 234	390 / 275	434 / 285	434 / 285
m1 (B5)	250	250	300	300	350	350	350	350	400	450	450
m1 (B14)	-	-	200	200	-	-	-	-	-	-	-
p1	-	-	724	724	770	770	789	789	822	830	830

"k1" ölçüsü frenli redüktörlere aittir.  
Dimensions "k1" is for motors with brake.  
Maße "k1" ist für Bremsenmotoren.

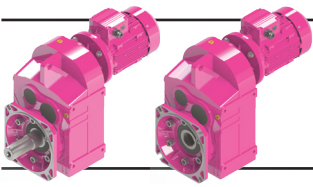

# Ölçü Sayfaları

## Dimension Pages

### Abmessungsseiten

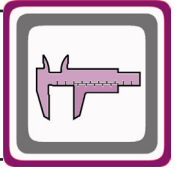

Mil ucu çektirme deliği DIN 332 sayfa 2 / Tapped center hole according to DIN 332, sheet 2 / Zentrierung mit Gewinde nach DIN 332, Blatt 2

DV772.02  
DV773.02

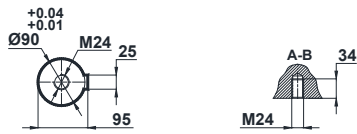
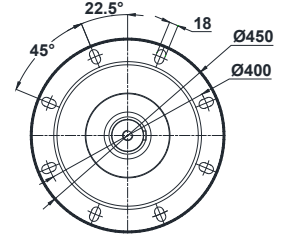
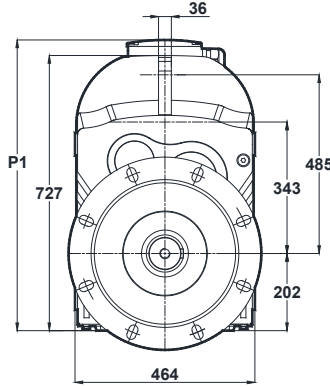
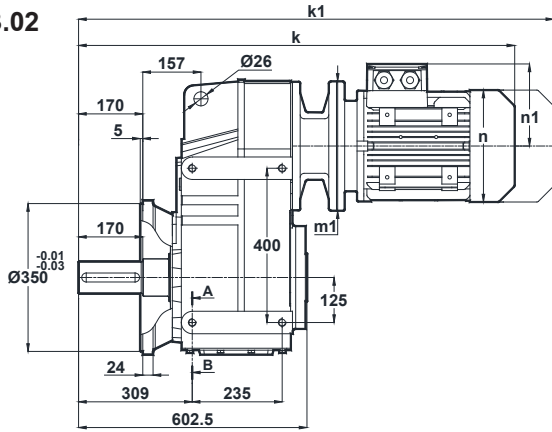

Opsiyonel flanş ölçüleri için sayfa 326'ya bakınız.  
Please see on page 326 for optional flange dimensions  
Siehe Seite 326 für auswählbare Flanschabmessungen

Klemens Pozisyonları  
Terminal Box Positions  
Klemmenkasten Positionen

	100L/B5	112M/B5	132S/B5 132S/B14	132M/B5 132M/B14	160M/B5	160L/B5	180M/B5	180L/B5	200L/B5	225S/B5	225M/B5
k	940	961	1060	1060	1214	1214	1304	1304	1362	1448	1473
k1	1059.5	1065.5	1190	1190	1394	1394	1474.5	1474.5	1548.5	1613	1638
n / n1	193 / 147	215 / 158	257 / 179	257 / 179	315 / 219	315 / 219	347 / 234	347 / 234	390 / 275	434 / 285	434 / 285
m1 (B5)	250	250	300	300	350	350	350	350	400	450	450
m1 (B14)	-	-	200	200	-	-	-	-	-	-	-
p1	-	-	724	724	770	770	789	789	822	830	830

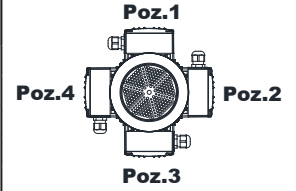

100-112-132-160-180-200-225  
Tip / Type / Typ

DV772.03  
DV773.03

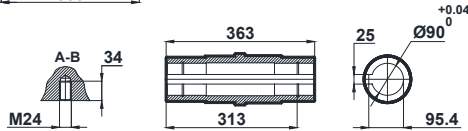
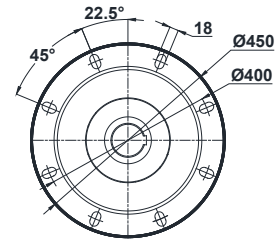
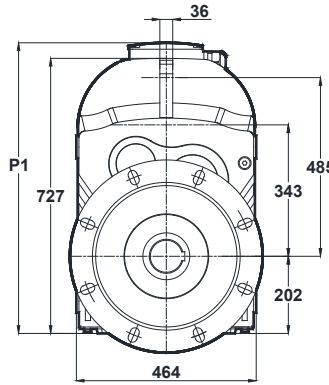
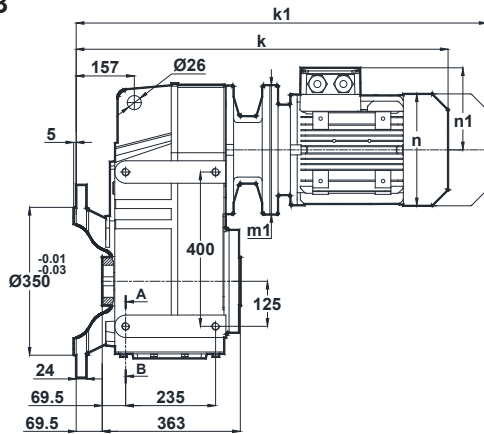

Klemens Pozisyonları  
Terminal Box Positions  
Klemmenkasten Positionen

	100L/B5	112M/B5	132S/B5 132S/B14	132M/B5 132M/B14	160M/B5	160L/B5	180M/B5	180L/B5	200L/B5	225S/B5	225M/B5
k	770	791	890	890	1044	1044	1134	1134	1192	1278	1303
k1	889.5	895.5	1020	1020	1224	1224	1304.5	1304.5	1378.5	1443	1468
n / n1	193 / 147	215 / 158	257 / 179	257 / 179	315 / 219	315 / 219	347 / 234	347 / 234	390 / 275	434 / 285	434 / 285
m1 (B5)	250	250	300	300	350	350	350	350	400	450	450
m1 (B14)	-	-	200	200	-	-	-	-	-	-	-
p1	-	-	724	724	770	770	789	789	822	830	830

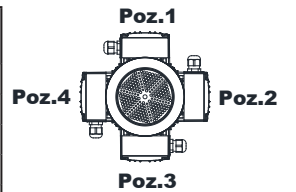

100-112-132-160-180-200-225  
Tip / Type / Typ

"k1" ölçüsü frenli redüktörlere aittir.  
Dimensions "k1" is for motors with brake.  
Maße "k1" ist für Bremsenmotoren.

Opsiyonel flanş ölçüleri için sayfa 326'ya bakınız.  
Please see on page 326 for optional flange dimensions  
Siehe Seite 326 für auswählbare Flanschabmessungen

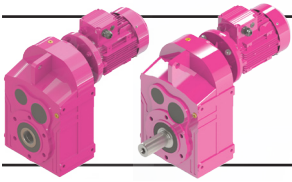

# Ölçü Sayfaları Dimension Pages Abmessungsseiten

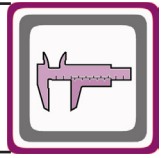

Mil ucu çektirme deliği DIN 332 sayfa 2 / Tapped center hole according to DIN 332, sheet 2 / Zentrierung mit Gewinde nach DIN 332, Blatt 2

DV774.00

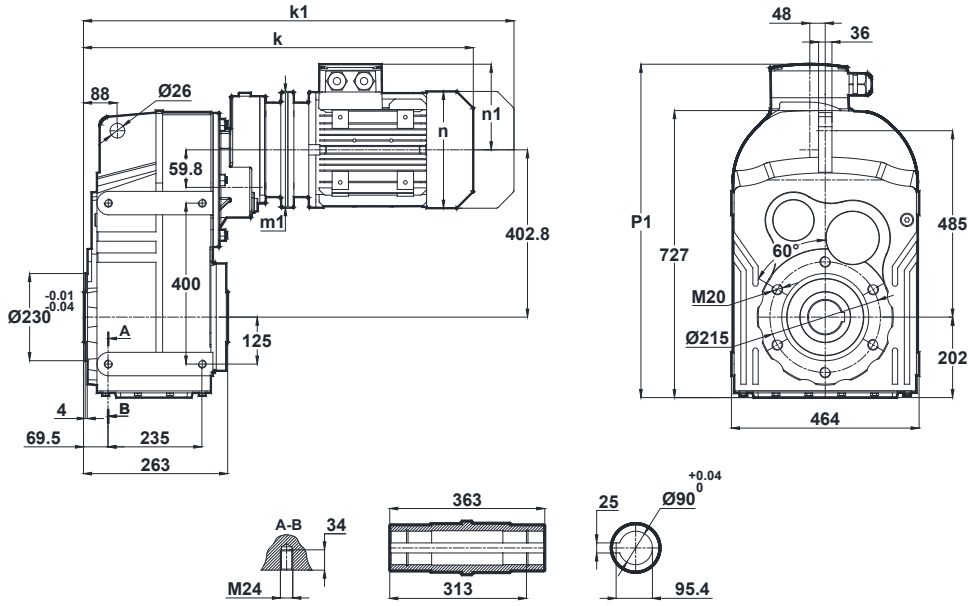

	80/B5	90S/B5 90S/B14	90L/B5 90L/B14	100L/B5 100L/B14
k	714	755	755	809
k1	807	859.5	859.5	928.5
n / n1	155 / 121	176 / 132	176 / 132	193 / 147
m1 (B5)	200	200	200	250
m1 (B14)	-	140	140	160
p1	-	737	737	752

Klemens Pozisyonları  
Terminal Box Positions  
Klemmenkasten Positionen

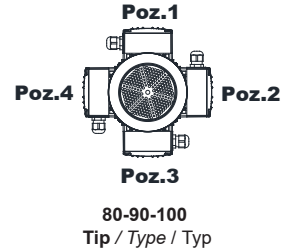

DV774.01

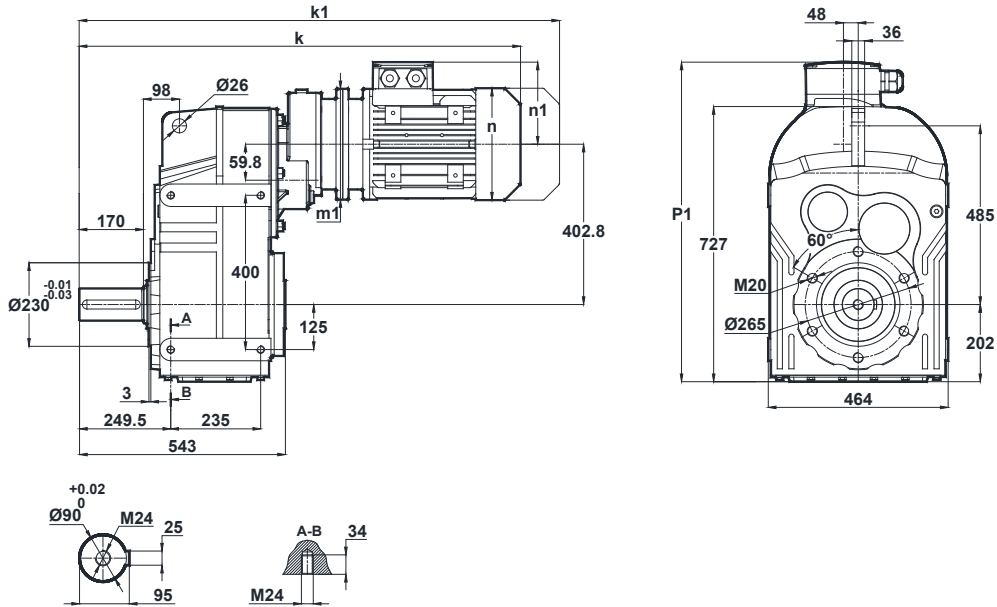

	80/B5	90S/B5 90S/B14	90L/B5 90L/B14	100L/B5 100L/B14
k	894	935	935	989
k1	987	1039.5	1039.5	1108.5
n / n1	155 / 121	176 / 132	176 / 132	193 / 147
m1 (B5)	200	200	200	250
m1 (B14)	-	140	140	160
p1	-	737	737	752

Klemens Pozisyonları  
Terminal Box Positions  
Klemmenkasten Positionen

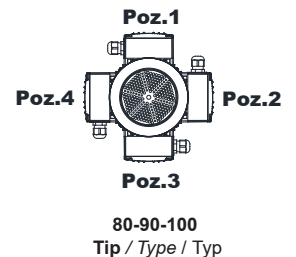

"k1" ölçüsü frenli redüktörlere aittir.  
Dimensions "k1" is for motors with brake.  
Maße "k1" ist für Bremsenmotoren.

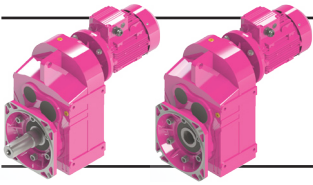

# Ölçü Sayfaları Dimension Pages Abmessungsseiten

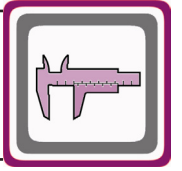

Mil ucu çektirme deliği DIN 332 sayfa 2 / Tapped center hole according to DIN 332, sheet 2 / Zentrierung mit Gewinde nach DIN 332, Blatt 2

## DV774.02

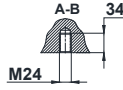
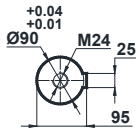
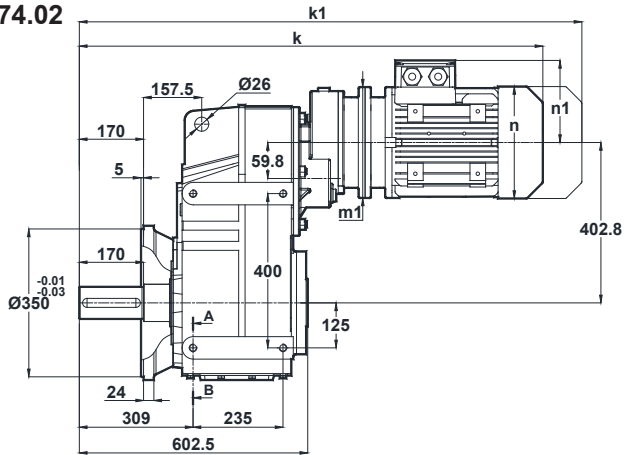

	80/B5	90S/B5 90S/B14	90L/B5 90L/B14	100L/B5 100L/B14
k	954	995	995	1049
k1	1047	1099.5	1099.5	1168.5
n / n1	155 / 121	176 / 132	176 / 132	193 / 147
m1 (B5)	200	200	200	250
m1 (B14)	-	140	140	160
p1	-	737	737	752

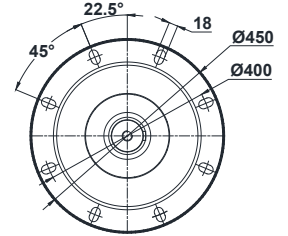
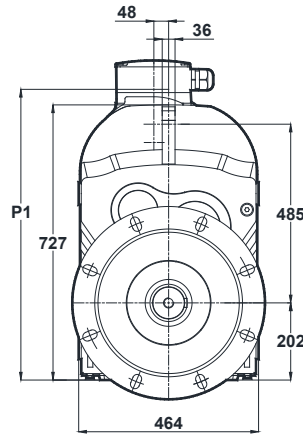

Klemens Pozisyonları  
Terminal Box Positions  
Klemmenkasten Positionen

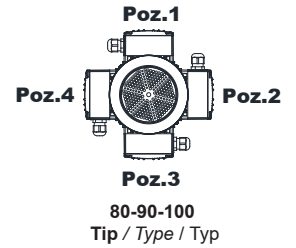

Opsiyonel flanş ölçüleri için sayfa 326'ya bakınız.  
Please see on page 326 for optional flange dimensions  
Siehe Seite 326 für auswählbare Flanschabmessungen

## DV774.03

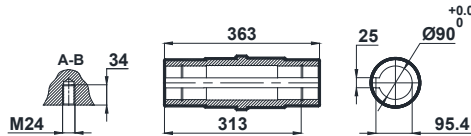
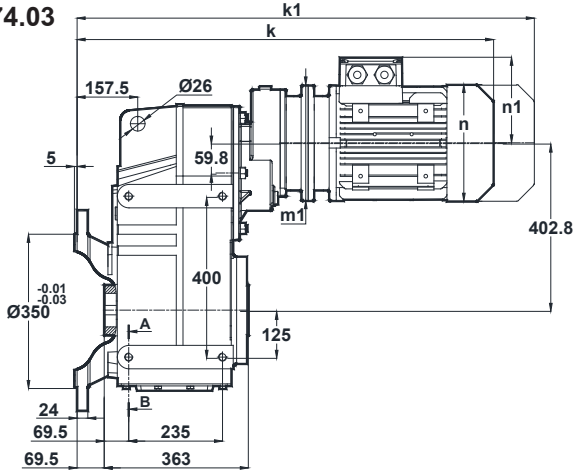

	80/B5	90S/B5 90S/B14	90L/B5 90L/B14	100L/B5 100L/B14
k	784	825	825	879
k1	877	929.5	929.5	998.5
n / n1	155 / 121	176 / 132	176 / 132	193 / 147
m1 (B5)	200	200	200	250
m1 (B14)	-	140	140	160
p1	-	737	737	752

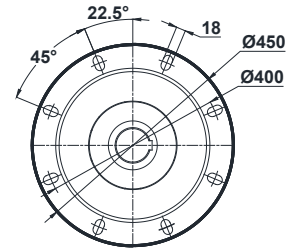
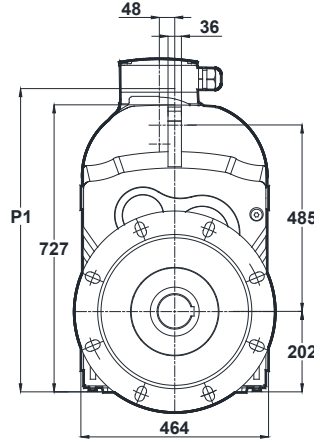

Klemens Pozisyonları  
Terminal Box Positions  
Klemmenkasten Positionen

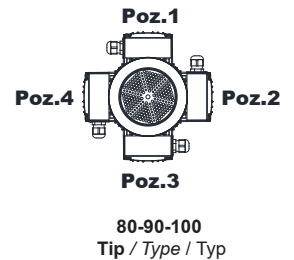

"k1" ölçüsü frenli redüktörlere aittir.  
Dimensions "k1" is for motors with brake.  
Maße "k1" ist für Bremsenmotoren.

Opsiyonel flanş ölçüleri için sayfa 326'ya bakınız.  
Please see on page 326 for optional flange dimensions  
Siehe Seite 326 für auswählbare Flanschabmessungen

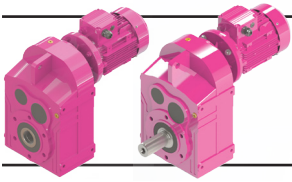

# Ölçü Sayfaları

## Dimension Pages

### Abmessungsseiten

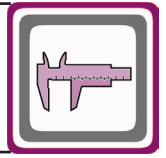

Mil ucu çektirme deliği DIN 332 sayfa 2 / Tapped center hole according to DIN 332, sheet 2 / Zentrierung mit Gewinde nach DIN 332, Blatt 2

DV775.00  
DV776.00

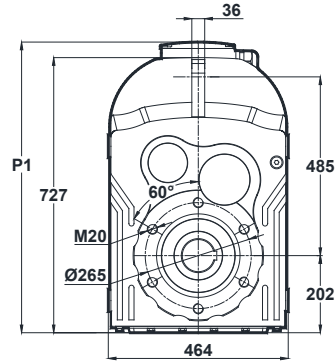
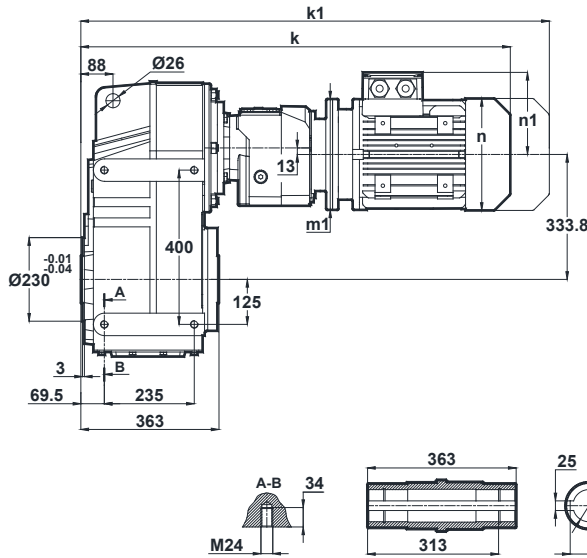

Klemens Pozisyonları  
Terminal Box Positions  
Klemmenkasten Positionen

	71/B5	80/B5 80/B14	90S/B5 90S/B14	90L/B5 90L/B14
k	841	864	905	905
k1	932	957	1009.5	1009.5
n / n1	137 / 112	155 / 121	176 / 132	176 / 132
m1 (B5)	160	200	200	200
m1 (B14)	-	120	140	140
p1	-	-	-	-

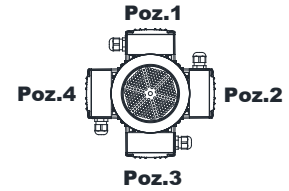

71-80-90  
Tip / Type / Typ

DV775.01  
DV776.01

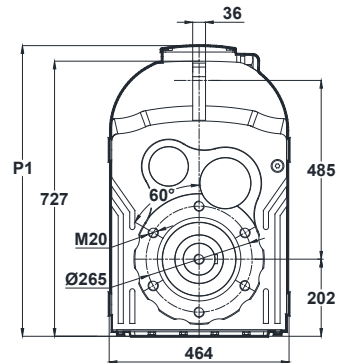
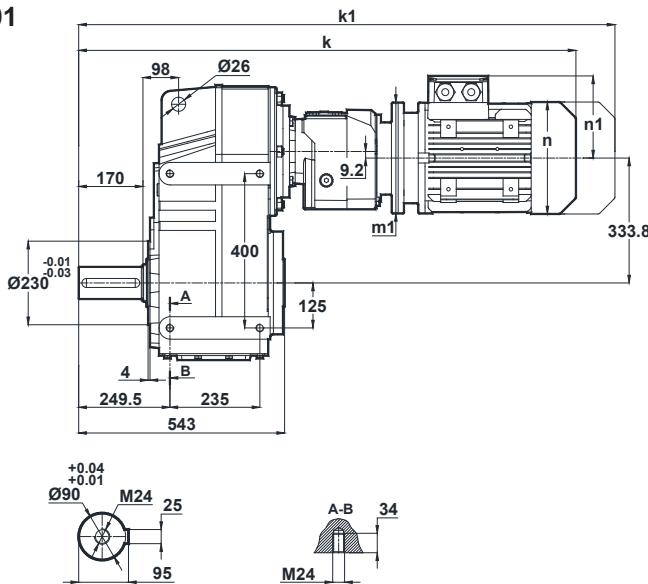

Klemens Pozisyonları  
Terminal Box Positions  
Klemmenkasten Positionen

	71/B5	80/B5 80/B14	90S/B5 90S/B14	90L/B5 90L/B14
k	1021	1044	1085	1085
k1	1112	1137	1189.5	1189.5
n / n1	137 / 112	155 / 121	176 / 132	176 / 132
m1 (B5)	160	200	200	200
m1 (B14)	-	120	140	140
p1	-	-	-	-

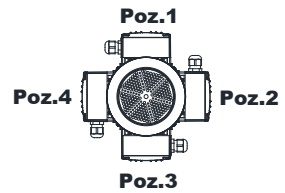

71-80-90  
Tip / Type / Typ

"k1" ölçüsü frenli redüktörlere aittir.  
Dimensions "k1" is for motors with brake.  
Maße "k1" ist für Bremsenmotoren.

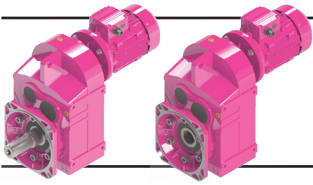

# Ölçü Sayfaları Dimension Pages Abmessungsseiten

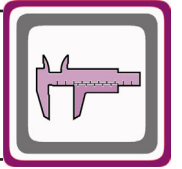

Mil ucu çektirme deliği DIN 332 sayfa 2 / Tapped center hole according to DIN 332, sheet 2 / Zentrierung mit Gewinde nach DIN 332, Blatt 2

DV775.02  
DV776.02

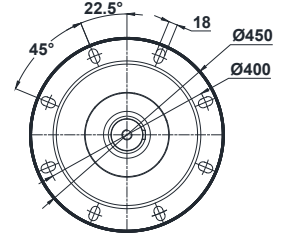
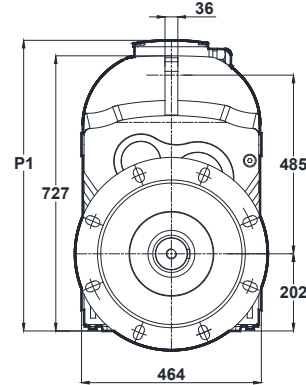
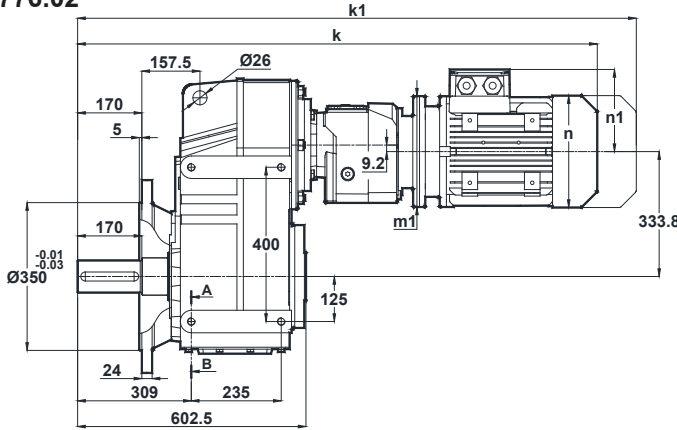

Klemens Pozisyonları  
Terminal Box Positions  
Klemmenkasten Positionen

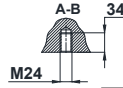
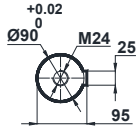

	71/B5	80/B5 80/B14	90S/B5 90S/B14	90L/B5 90L/B14
k	1081	1104	1145	1145
k1	1172	1197	1249.5	1249.5
n / n1	137 / 112	155 / 121	176 / 132	176 / 132
m1 (B5)	160	200	200	200
m1 (B14)	-	120	140	140
p1	-	-	-	-

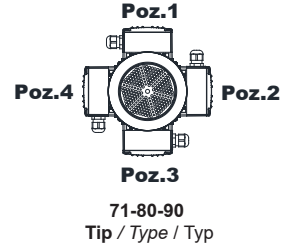

Opsiyonel flanş ölçüleri için sayfa 326'ya bakınız.  
Please see on page 326 for optional flange dimensions  
Siehe Seite 326 für auswählbare Flanschabmessungen

DV775.03  
DV776.03

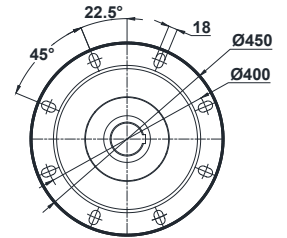
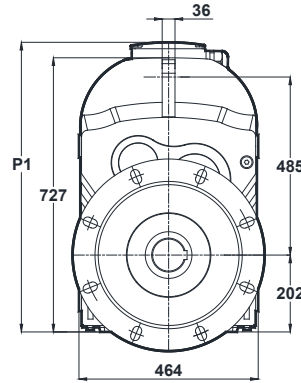
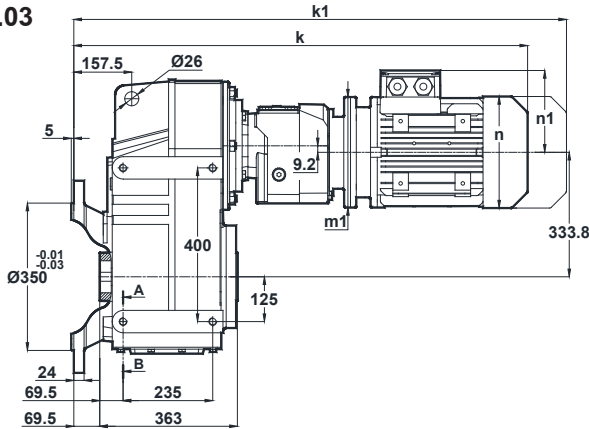

Klemens Pozisyonları  
Terminal Box Positions  
Klemmenkasten Positionen

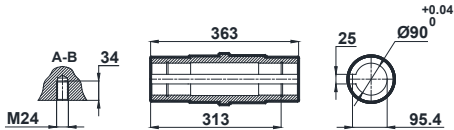

	71/B5	80/B5 80/B14	90S/B5 90S/B14	90L/B5 90L/B14
k	911	934	975	975
k1	1002	1027	1079.5	1079.5
n / n1	137 / 112	155 / 121	176 / 132	176 / 132
m1 (B5)	160	200	200	200
m1 (B14)	-	120	140	140
p1	-	-	-	-

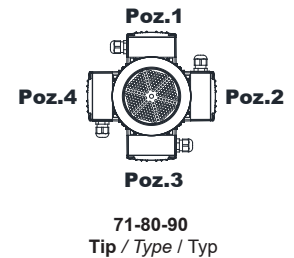

"k1" ölçüsü frenli redüktörlere aittir.  
Dimensions "k1" is for motors with brake.  
Maße "k1" ist für Bremsenmotoren.

Opsiyonel flanş ölçüleri için sayfa 326'ya bakınız.  
Please see on page 326 for optional flange dimensions  
Siehe Seite 326 für auswählbare Flanschabmessungen

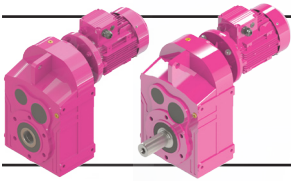

# Ölçü Sayfaları Dimension Pages Abmessungsseiten

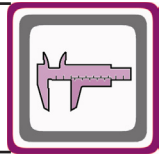

Mil ucu çektirme deliği DIN 332 sayfa 2 / Tapped center hole according to DIN 332, sheet 2 / Zentrierung mit Gewinde nach DIN 332, Blatt 2

DV872.00  
DV873.00

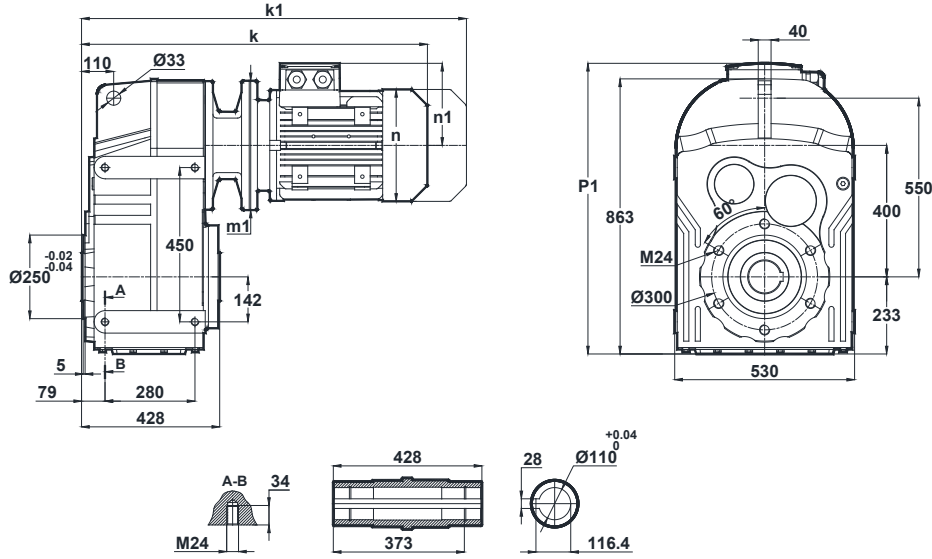

Klemens Pozisyonları  
Terminal Box Positions  
Klemmenkasten Positionen

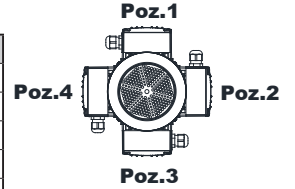

	132S/B5	132M/B5	160M/B5	160L/B5	180M/B5	180L/B5	200L/B5	225S/B5	225M/B5	250M/B5	280S/B5	280M/B5
k	872	872	1097	1097	1186	1186	1224	1257	1282	1358	1420	1420
k1	1002	1002	1277	1277	1356.5	1356.5	1410.5	1422	1447	1528.5	1593	1599
n / n1	257 / 179	257 / 179	315 / 219	315 / 219	347 / 234	347 / 234	390 / 275	434 / 285	434 / 285	480 / 322	544 / 350	544 / 350
m1 (B5)	300	300	350	350	350	350	400	450	450	550	550	550
p1	-	-	-	-	877	877	908	918	918	955	983	983

132-160-180-200-225-250-280  
Tip / Type / Typ

DV872.01  
DV873.01

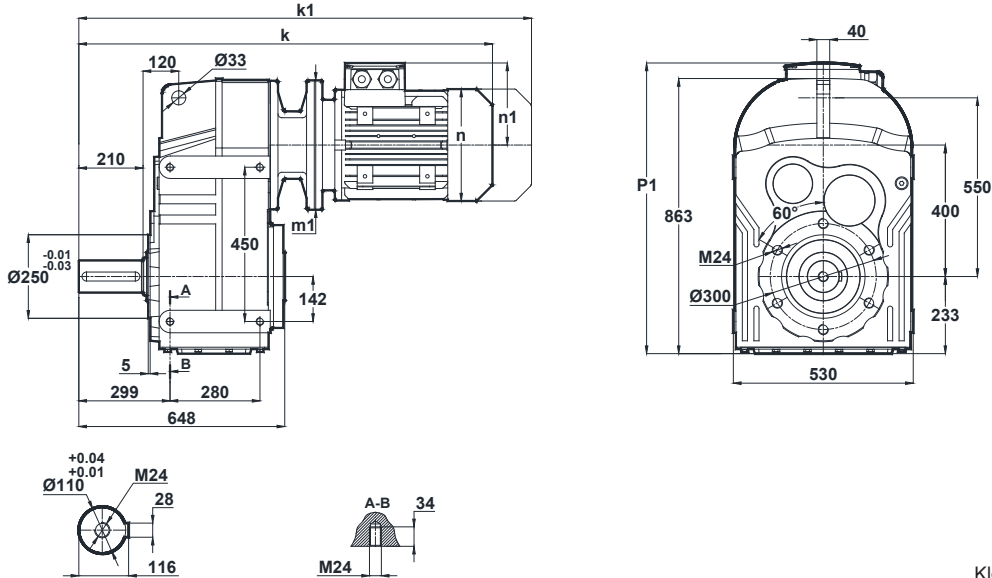

Klemens Pozisyonları  
Terminal Box Positions  
Klemmenkasten Positionen

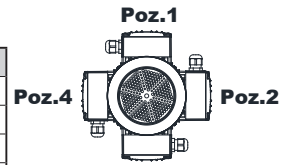

	132S/B5	132M/B5	160M/B5	160L/B5	180M/B5	180L/B5	200L/B5	225S/B5	225M/B5	250M/B5	280S/B5	280M/B5
k	1092	1092	1317	1317	1406	1406	1444	1477	1502	1578	1640	1640
k1	1222	1222	1497	1497	1576.5	1576.5	1630.5	1642	1667	1748.5	1813	1819
n / n1	257 / 179	257 / 179	315 / 219	315 / 219	347 / 234	347 / 234	390 / 275	434 / 285	434 / 285	480 / 322	544 / 350	544 / 350
m1 (B5)	300	300	350	350	350	350	400	450	450	550	550	550
p1	-	-	-	-	877	877	908	918	918	955	983	983

132-160-180-200-225-250-280  
Tip / Type / Typ

"k1" ölçüsü frenli redüktörlere aittir.  
Dimensions "k1" is for motors with brake.  
Maße "k1" ist für Bremsenmotoren.

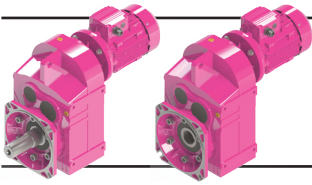

# Ölçü Sayfaları Dimension Pages Abmessungsseiten

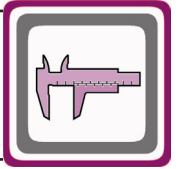

Mil ucu çektirme deliği DIN 332 sayfa 2 / Tapped center hole according to DIN 332, sheet 2 / Zentrierung mit Gewinde nach DIN 332, Blatt 2

DV872.02  
DV873.02

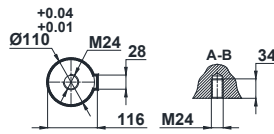
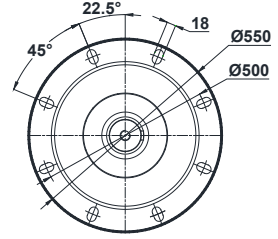
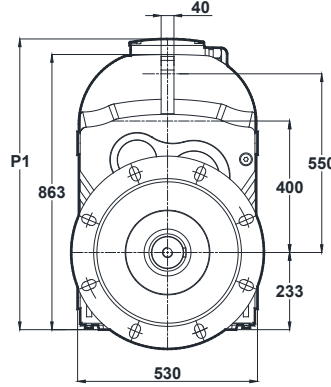
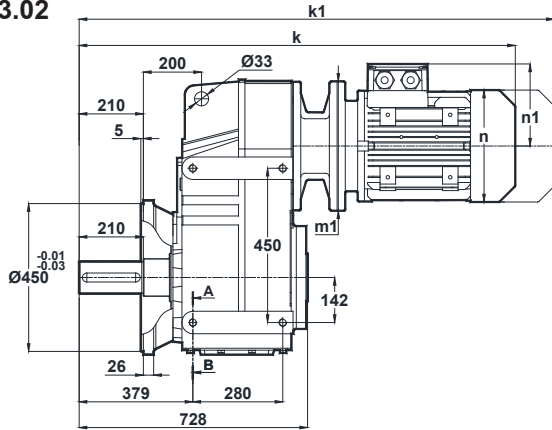

Opsiyonel flanş ölçüleri için sayfa 326'ya bakınız.  
Please see on page 326 for optional flange dimensions  
Siehe Seite 326 für auswählbare Flanschabmessungen

Klemens Pozisyonları  
Terminal Box Positions  
Klemmenkasten Positionen

	132S/B5	132M/B5	160M/B5	160L/B5	180M/B5	180L/B5	200L/B5	225S/B5	225M/B5	250M/B5	280S/B5	280M/B5
k	1172	1172	1397	1397	1486	1486	1524	1557	1582	1658	1720	1720
k1	1302	1302	1577	1577	1656.5	1656.5	1710.5	1722	1747	1828.5	1893	1899
n / n1	257 / 179	257 / 179	315 / 219	315 / 219	347 / 234	347 / 234	390 / 275	434 / 285	434 / 285	480 / 322	544 / 350	544 / 350
m1 (B5)	300	300	350	350	350	350	400	450	450	550	550	550
p1	-	-	-	-	877	877	908	918	918	955	983	983

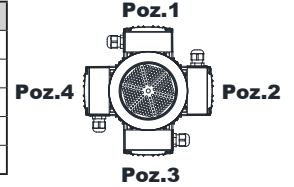

132-160-180-200-225-250-280  
Tip / Type / Typ

DV872.03  
DV873.03

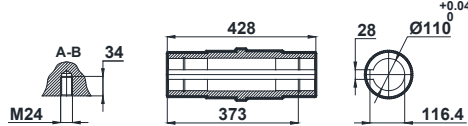
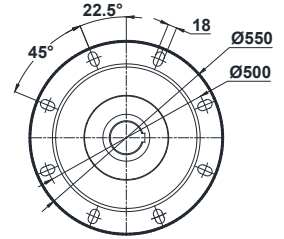
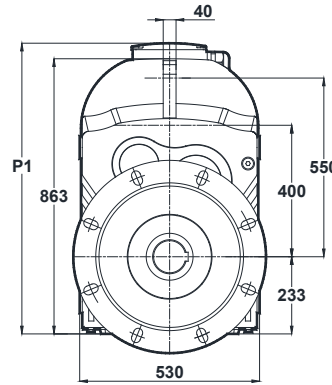
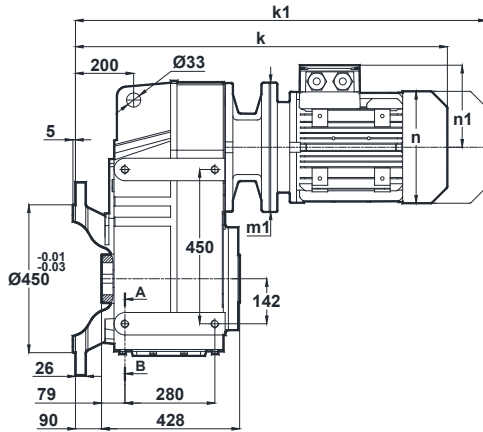

Klemens Pozisyonları  
Terminal Box Positions  
Klemmenkasten Positionen

	132S/B5	132M/B5	160M/B5	160L/B5	180M/B5	180L/B5	200L/B5	225S/B5	225M/B5	250M/B5	280S/B5	280M/B5
k	962	962	1187	1187	1276	1276	1314	1347	1372	1448	1510	1510
k1	1092	1092	1367	1367	1446.5	1446.5	1500.5	1512	1537	1618.5	1683	1689
n / n1	257 / 179	257 / 179	315 / 219	315 / 219	347 / 234	347 / 234	390 / 275	434 / 285	434 / 285	480 / 322	544 / 350	544 / 350
m1 (B5)	300	300	350	350	350	350	400	450	450	550	550	550
p1	-	-	-	-	877	877	908	918	918	955	983	983

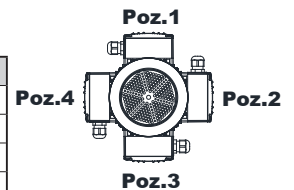

132-160-180-200-225-250-280  
Tip / Type / Typ

"k1" ölçüsü frenli redüktörlere aittir.  
Dimensions "k1" is for motors with brake.  
Maße "k1" ist für Bremsenmotoren.

Opsiyonel flanş ölçüleri için sayfa 326'ya bakınız.  
Please see on page 326 for optional flange dimensions  
Siehe Seite 326 für auswählbare Flanschabmessungen

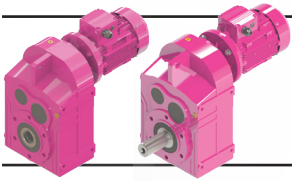

# Ölçü Sayfaları Dimension Pages Abmessungenseiten

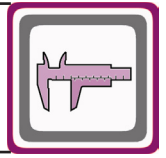

Mil ucu çektirme deliği DIN 332 sayfa 2 / Tapped center hole according to DIN 332, sheet 2 / Zentrierung mit Gewinde nach DIN 332, Blatt 2

## DV874.00

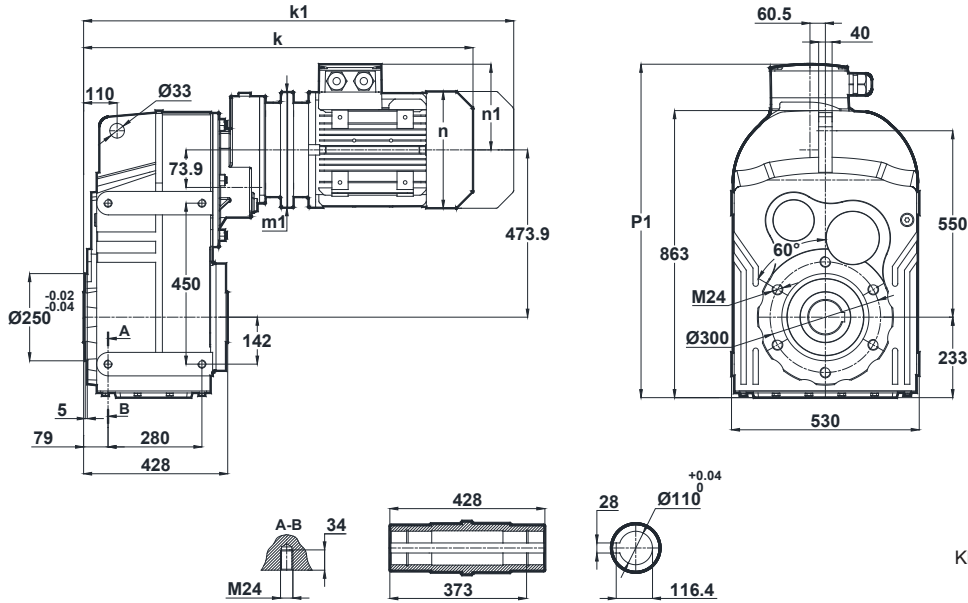

Klemens Pozisyonları  
Terminal Box Positions  
Klemmenkasten Positionen

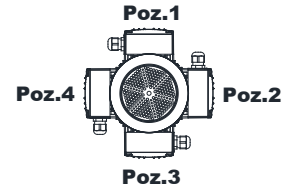

	100L/B5	112M/B5	132S/B5 132S/B14	132M/B5 132M/B14
k	885	906	1011	1011
k1	1004.5	1010.5	1141	1141
n / n1	193 / 147	215 / 158	257 / 179	257 / 179
m1 (B5)	250	250	300	300
m1 (B14)	-	-	200	200
p1	-	-	886	886

100-112-132  
Tip / Type / Typ

## DV874.01

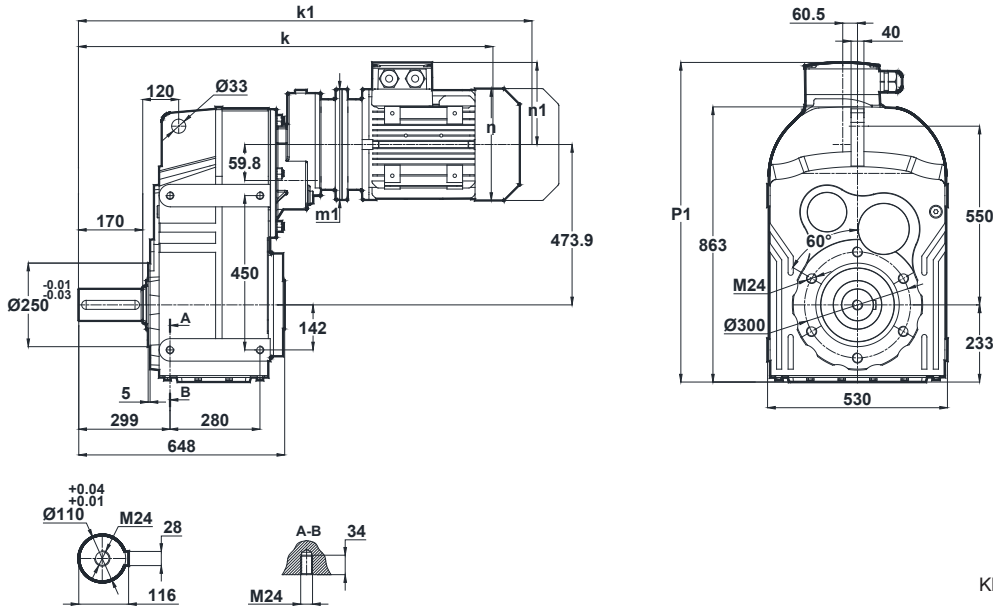

Klemens Pozisyonları  
Terminal Box Positions  
Klemmenkasten Positionen

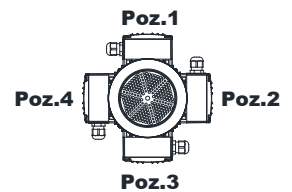

	100L/B5	112M/B5	132S/B5 132S/B14	132M/B5 132M/B14
k	1105	1126	1231	1231
k1	1224.5	1230.5	1361	1361
n / n1	193 / 147	215 / 158	257 / 179	257 / 179
m1 (B5)	250	250	300	300
m1 (B14)	-	-	200	200
p1	-	-	886	886

100-112-132  
Tip / Type / Typ

"k1" ölçüsü frenli redüktörlere aittir.  
Dimensions "k1" is for motors with brake.  
Maße "k1" ist für Bremsenmotoren.

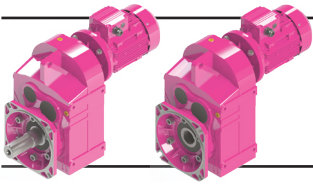

# Ölçü Sayfaları Dimension Pages Abmessungsseiten

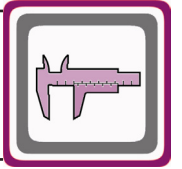

Mil ucu çektirme deliği DIN 332 sayfa 2 / Tapped center hole according to DIN 332, sheet 2 / Zentrierung mit Gewinde nach DIN 332, Blatt 2

## DV874.02

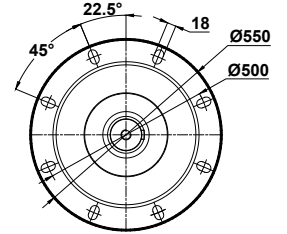
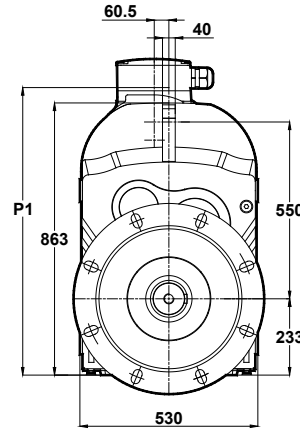
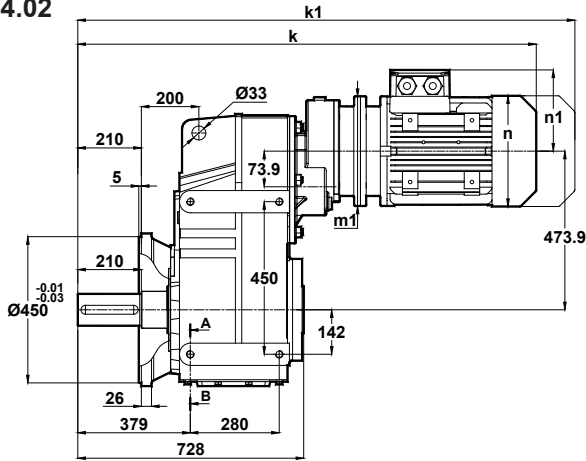

Klemens Pozisyonları  
Terminal Box Positions  
Klemmenkasten Positionen

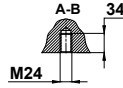
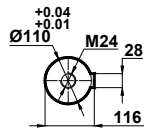

	100L/B5	112M/B5	132S/B5 132S/B14	132M/B5 132M/B14
k	1185	1206	1311	1311
k1	1304.5	1310.5	1441	1441
n / n1	193 / 147	215 / 158	257 / 179	257 / 179
m1 (B5)	250	250	300	300
m1 (B14)	-	-	200	200
p1	-	-	886	886

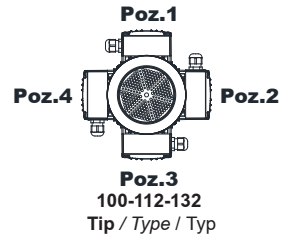

Opsiyonel flanş ölçüleri için sayfa 326'ya bakınız.  
Please see on page 326 for optional flange dimensions  
Siehe Seite 326 für auswählbare Flanschabmessungen

## DV874.03

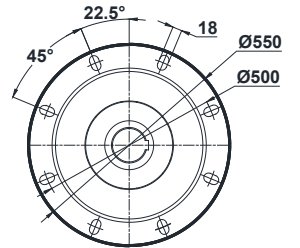
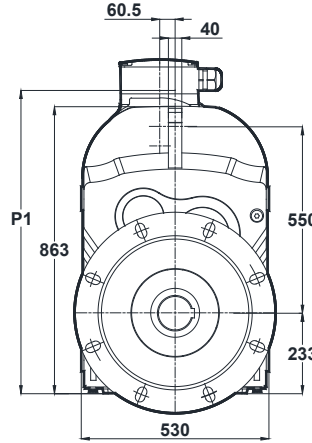
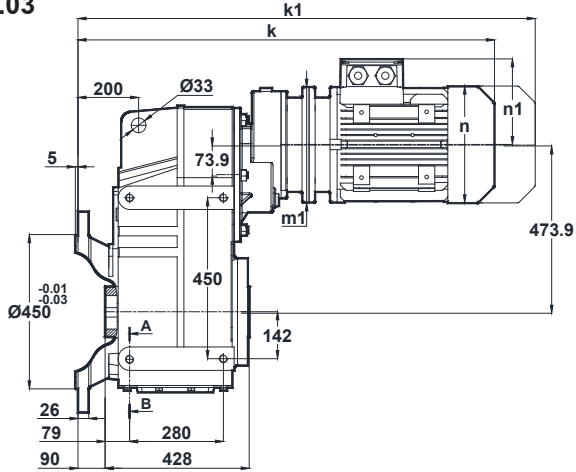

Klemens Pozisyonları  
Terminal Box Positions  
Klemmenkasten Positionen

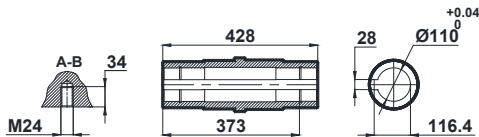

	100L/B5	112M/B5	132S/B5 132S/B14	132M/B5 132M/B14
k	975	996	1101	1101
k1	1094.5	1100.5	1231	1231
n / n1	193 / 147	215 / 158	257 / 179	257 / 179
m1 (B5)	250	250	300	300
m1 (B14)	-	-	200	200
p1	-	-	886	886

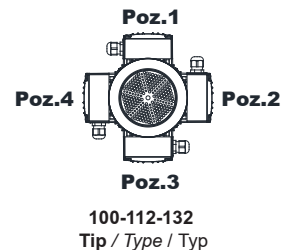

Opsiyonel flanş ölçüleri için sayfa 326'ya bakınız.  
Please see on page 326 for optional flange dimensions  
Siehe Seite 326 für auswählbare Flanschabmessungen

"k1" ölçüsü frenli redüktörlere aittir.  
Dimensions "k1" is for motors with brake.  
Maße "k1" ist für Bremsenmotoren.

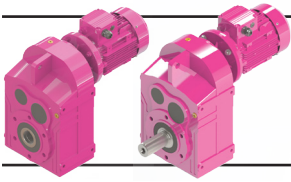

# Ölçü Sayfaları Dimension Pages Abmessungsseiten

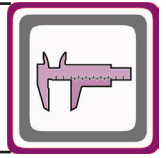

Mil ucu çektirme deliği DIN 332 sayfa 2 / Tapped center hole according to DIN 332, sheet 2 / Zentrierung mit Gewinde nach DIN 332, Blatt 2

DV875.00  
DV876.00

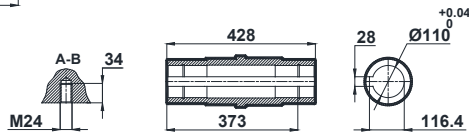
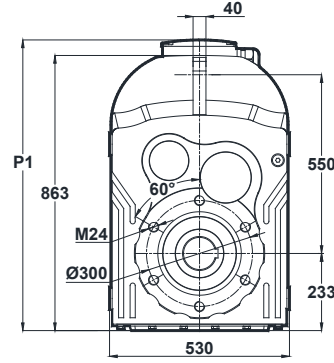
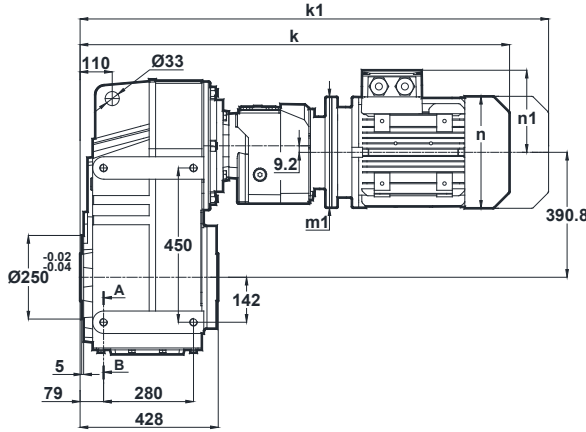

Klemens Pozisyonları  
Terminal Box Positions  
Klemmenkasten Positionen

	71/B5	80/B5 80/B14	90S/B5 90S/B14	90L/B5 90L/B14	100L/B5 100L/B14
k	904	927	968	968	1020
k1	995	1020	1072.5	1072.5	1139.5
n / n1	137 / 112	155 / 121	176 / 132	176 / 132	193 / 193
m1 (B5)	160	200	200	200	250
m1 (B14)	-	120	140	140	160
p1	736	745	756	756	771

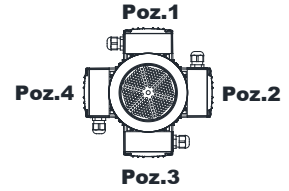

71-80-90-100  
Tip / Type / Typ

DV875.01  
DV876.01

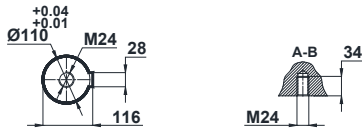
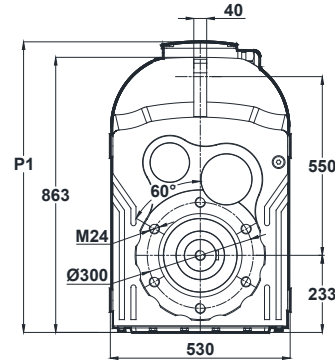
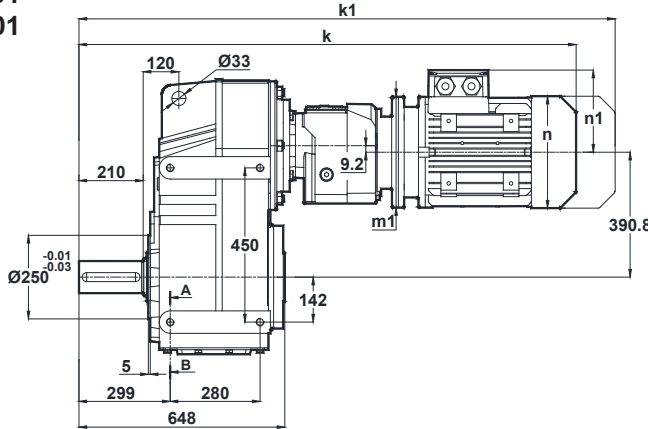

Klemens Pozisyonları  
Terminal Box Positions  
Klemmenkasten Positionen

	71/B5	80/B5 80/B14	90S/B5 90S/B14	90L/B5 90L/B14	100L/B5 100L/B14
k	1124	1147	1188	1188	1240
k1	1215	1240	1292.5	1292.5	1359.5
n / n1	137 / 112	155 / 121	176 / 132	176 / 132	193 / 193
m1 (B5)	160	200	200	200	250
m1 (B14)	-	120	140	140	160
p1	736	745	756	756	771

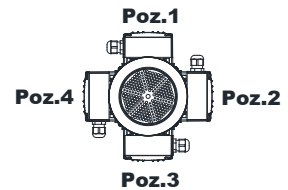

71-80-90-100  
Tip / Type / Typ

"k1" ölçüsü frenli redüktörlere aittir.  
Dimensions "k1" is for motors with brake.  
Maße "k1" ist für Bremsenmotoren.

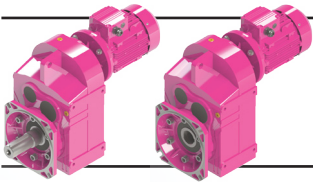

# Ölçü Sayfaları Dimension Pages Abmessungsseiten

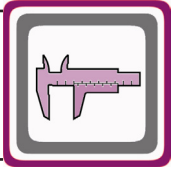

Mil ucu çektirme deliği DIN 332 sayfa 2 / Tapped center hole according to DIN 332, sheet 2 / Zentrierung mit Gewinde nach DIN 332, Blatt 2

DV875.02  
DV876.02

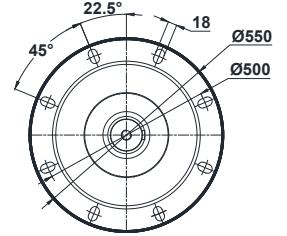
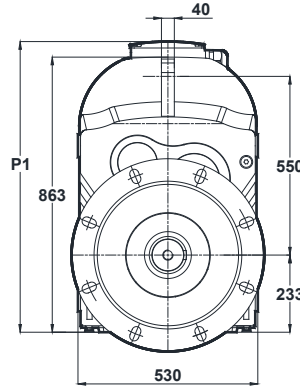
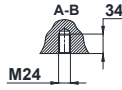
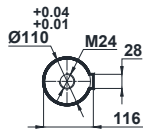
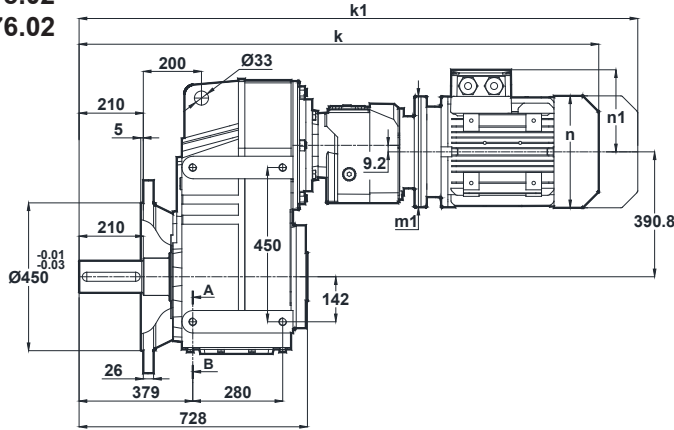

Klemens Pozisyonları  
Terminal Box Positions  
Klemmenkasten Positionen

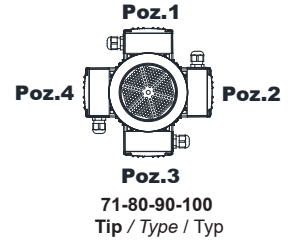

	71/B5	80/B5 80/B14	90S/B5 90S/B14	90L/B5 90L/B14	100L/B5 100L/B14
k	1204	1227	1268	1268	1320
k1	1295	1320	1372.5	1372.5	1439.5
n / n1	137 / 112	155 / 121	176 / 132	176 / 132	193 / 193
m1 (B5)	160	200	200	200	250
m1 (B14)	-	120	140	140	160
p1	736	745	756	756	771

Opsiyonel flanş ölçüleri için sayfa 326'ya bakınız.  
Please see on page 326 for optional flange dimensions  
Siehe Seite 326 für auswählbare Flanschabmessungen

DV875.03  
DV876.03

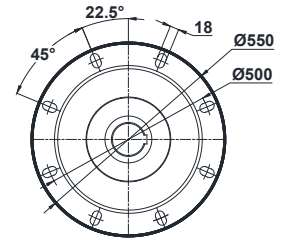
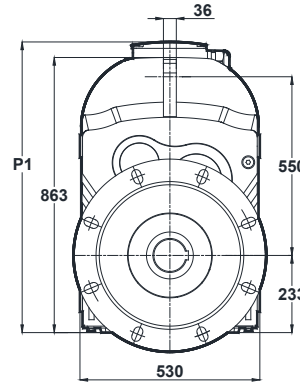
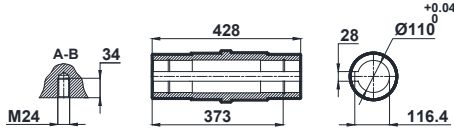
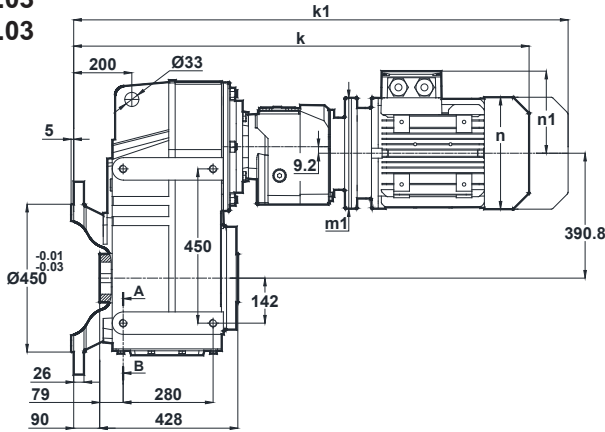

Klemens Pozisyonları  
Terminal Box Positions  
Klemmenkasten Positionen

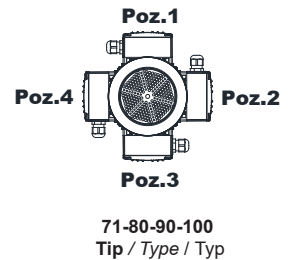

	71/B5	80/B5 80/B14	90S/B5 90S/B14	90L/B5 90L/B14	100L/B5 100L/B14
k	994	1017	1058	1058	1110
k1	1085	1110	1162.5	1162.5	1229.5
n / n1	137 / 112	155 / 121	176 / 132	176 / 132	193 / 193
m1 (B5)	160	200	200	200	250
m1 (B14)	-	120	140	140	160
p1	736	745	756	756	771

Opsiyonel flanş ölçüleri için sayfa 326'ya bakınız.  
Please see on page 326 for optional flange dimensions  
Siehe Seite 326 für auswählbare Flanschabmessungen

"k1" ölçüsü frenli redüktörlere aittir.  
Dimensions "k1" is for motors with brake.  
Maße "k1" ist für Bremsenmotoren.

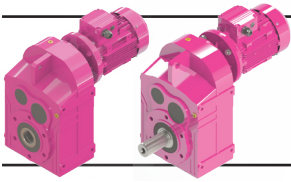

# Ölçü Sayfaları Dimension Pages Abmessungsseiten

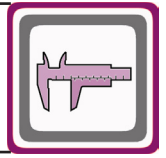

Mil ucu çektirme deliği DIN 332 sayfa 2 / Tapped center hole according to DIN 332, sheet 2 / Zentrierung mit Gewinde nach DIN 332, Blatt 2

DV972.00  
DV973.00

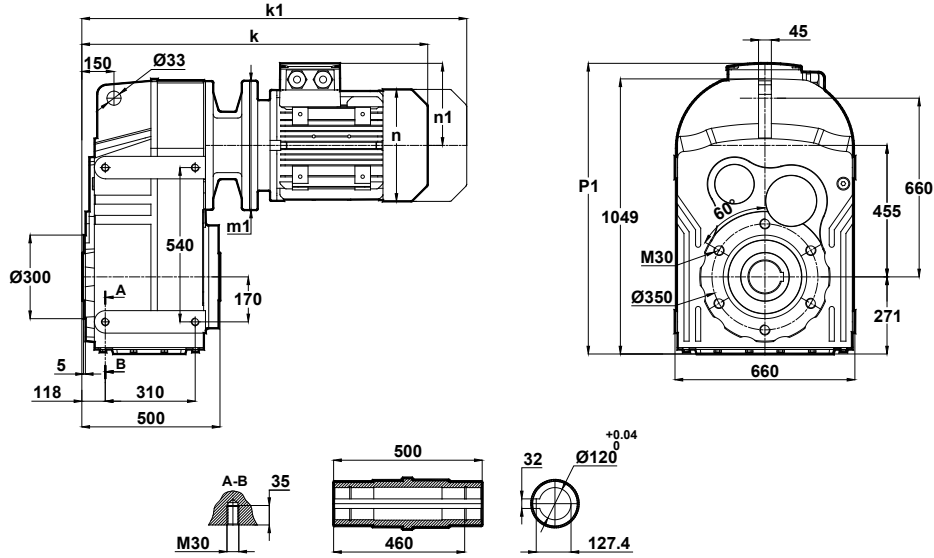

Klemens Pozisyonları  
Terminal Box Positions  
Klemmenkasten Positionen

	160M/B5	160L/B5	180M/B5	180L/B5	200L/B5	225S/B5	225M/B5	250M/B5	280S/B5	280M/B5	315S/B5	315M/B5
k	1086	1086	1175	1175	1237	1312	1337	1465	1527	1527	1739	1739
k1	1246	1246	1345.5	1345.5	1423.5	1477	1502	1635.5	1700	1706	-	-
n / n1	315 / 219	315 / 219	347 / 234	347 / 234	390 / 275	434 / 285	434 / 285	480 / 322	544 / 350	544 / 350	614 / 510	614 / 510
m1 (B5)	350	350	350	350	400	450	450	550	550	550	660	660
m1 (B14)	-	-	-	-	-	-	-	-	-	-	-	-
p1	-	-	-	-	-	-	-	-	1076	1076	1236	1236

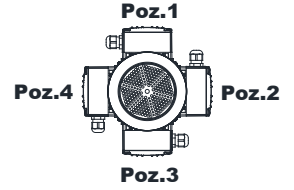

160-180-200-225-250-280-315  
Tip / Type / Typ

DV972.01  
DV973.01

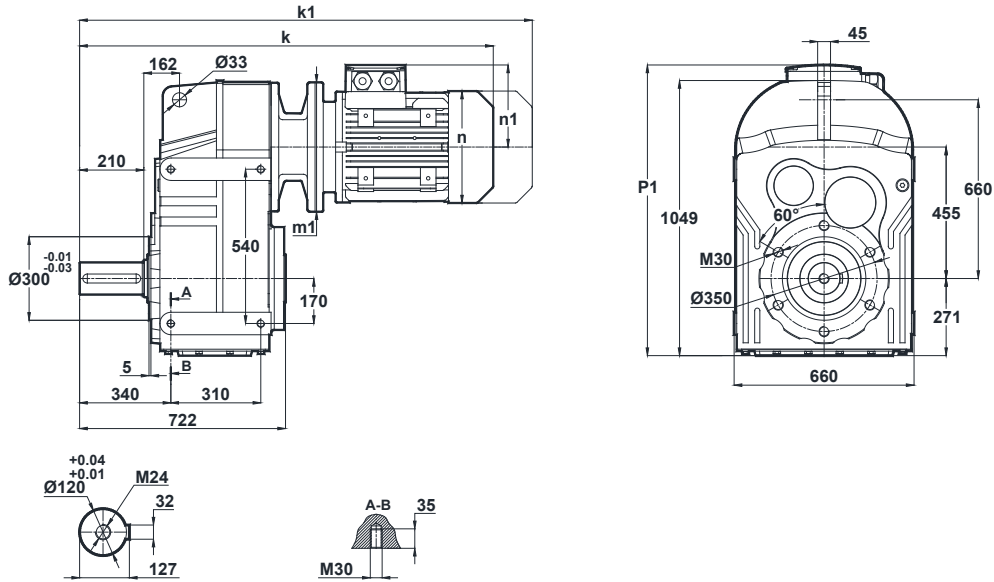

Klemens Pozisyonları  
Terminal Box Positions  
Klemmenkasten Positionen

	160M/B5	160L/B5	180M/B5	180L/B5	200L/B5	225S/B5	225M/B5	250M/B5	280S/B5	280M/B5	315S/B5	315M/B5
k	1308	1308	1397	1397	1459	1534	1559	1687	1749	1749	1961	1961
k1	1488	1488	1567.5	1567.5	1645.5	1699	1724	1857.5	1922	1928	-	-
n / n1	315 / 219	315 / 219	347 / 234	347 / 234	390 / 275	434 / 285	434 / 285	480 / 322	544 / 350	544 / 350	614 / 510	614 / 510
m1 (B5)	350	350	350	350	400	450	450	550	550	550	660	660
m1 (B14)	-	-	-	-	-	-	-	-	-	-	-	-
p1	-	-	-	-	-	-	-	-	1076	1076	1236	1236

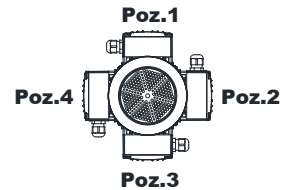

160-180-200-225-250-280-315  
Tip / Type / Typ

"k1" ölçüsü frenli redüktörlere aittir.  
Dimensions "k1" is for motors with brake.  
Maße "k1" ist für Bremsenmotoren.

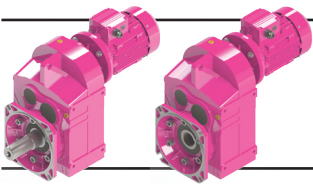

# Ölçü Sayfaları Dimension Pages Abmessungsseiten

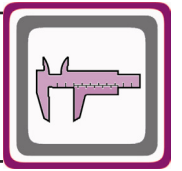

Mil ucu çektirme deliği DIN 332 sayfa 2 / Tapped center hole according to DIN 332, sheet 2 / Zentrierung mit Gewinde nach DIN 332, Blatt 2

DV972.02  
DV973.02

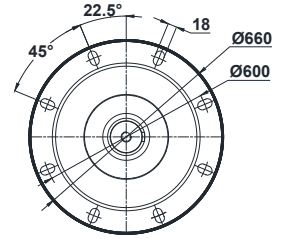
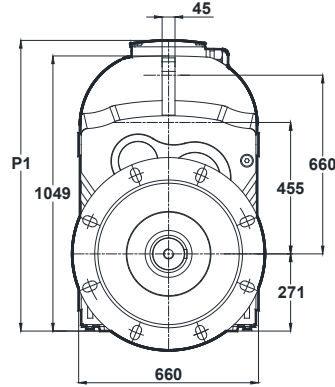
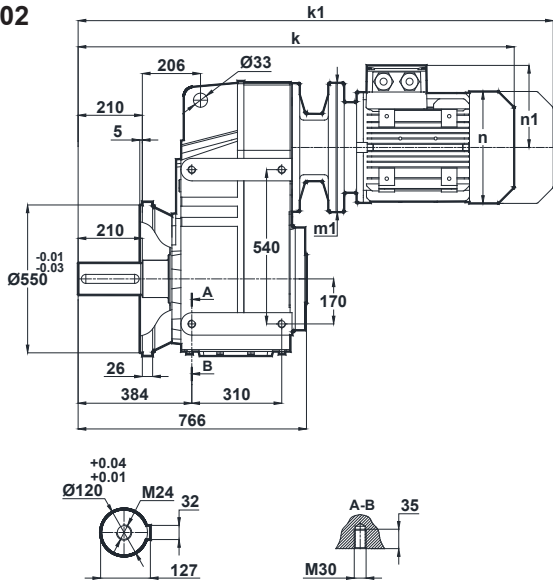

Klemens Pozisyonları  
Terminal Box Positions  
Klemmenkasten Positionen

	160M/B5	160L/B5	180M/B5	180L/B5	200L/B5	225S/B5	225M/B5	250M/B5	280S/B5	280M/B5	315S/B5	315M/B5
k	1352	1352	1441	1441	1503	1578	1603	1731	1793	1793	2005	2005
k1	1532	1532	1611.5	1611.5	1689.5	1743	1768	1901.5	1966	1972	-	-
n / n1	315 / 219	315 / 219	347 / 234	347 / 234	390 / 275	434 / 285	434 / 285	480 / 322	544 / 350	544 / 350	614 / 510	614 / 510
m1 (B5)	350	350	350	350	400	450	450	550	550	550	660	660
m1 (B14)	-	-	-	-	-	-	-	-	-	-	-	-
p1	-	-	-	-	-	-	-	-	1076	1076	1236	1236

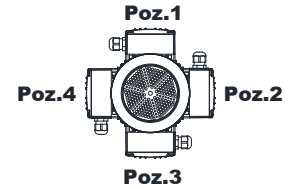

160-180-200-225-250-280-315  
Tip / Type / Typ

DV972.03  
DV973.03

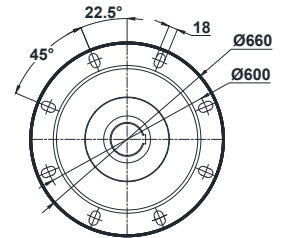
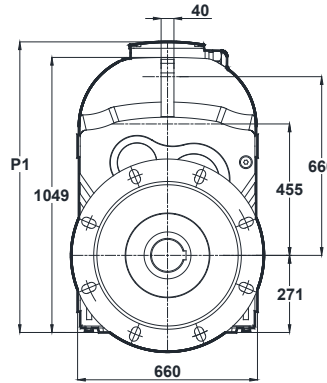
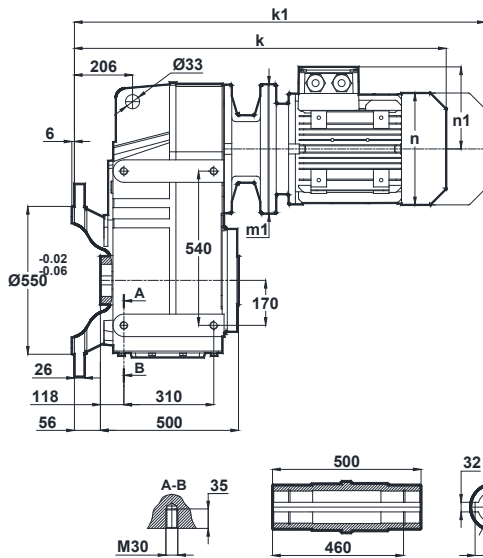

Klemens Pozisyonları  
Terminal Box Positions  
Klemmenkasten Positionen

	160M/B5	160L/B5	180M/B5	180L/B5	200L/B5	225S/B5	225M/B5	250M/B5	280S/B5	280M/B5	315S/B5	315M/B5
k	1142	1142	1231	1231	1293	1368	1393	1521	1583	1583	1795	1795
k1	1322	1322	1401.5	1401.5	1479.5	1533	1533	1686	1756	1762	-	-
n / n1	315 / 219	315 / 219	347 / 234	347 / 234	390 / 275	434 / 285	434 / 285	480 / 322	544 / 350	544 / 350	614 / 510	614 / 510
m1 (B5)	350	350	350	350	400	450	450	550	550	550	660	660
m1 (B14)	-	-	-	-	-	-	-	-	-	-	-	-
p1	-	-	-	-	-	-	-	-	1076	1076	1236	1236

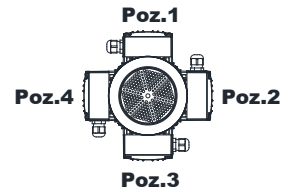

160-180-200-225-250-280-315  
Tip / Type / Typ

"k1" ölçüsü frenli redüktörlere aittir.  
Dimensions "k1" is for motors with brake.  
Maße "k1" ist für Bremsenmotoren.

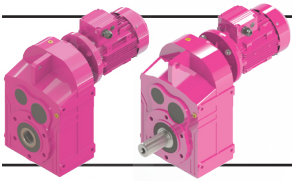

# Ölçü Sayfaları Dimension Pages Abmessungsseiten

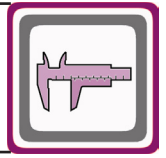

Mil ucu çektirme deliği DIN 332 sayfa 2 / Tapped center hole according to DIN 332, sheet 2 / Zentrierung mit Gewinde nach DIN 332, Blatt 2

DV974.00

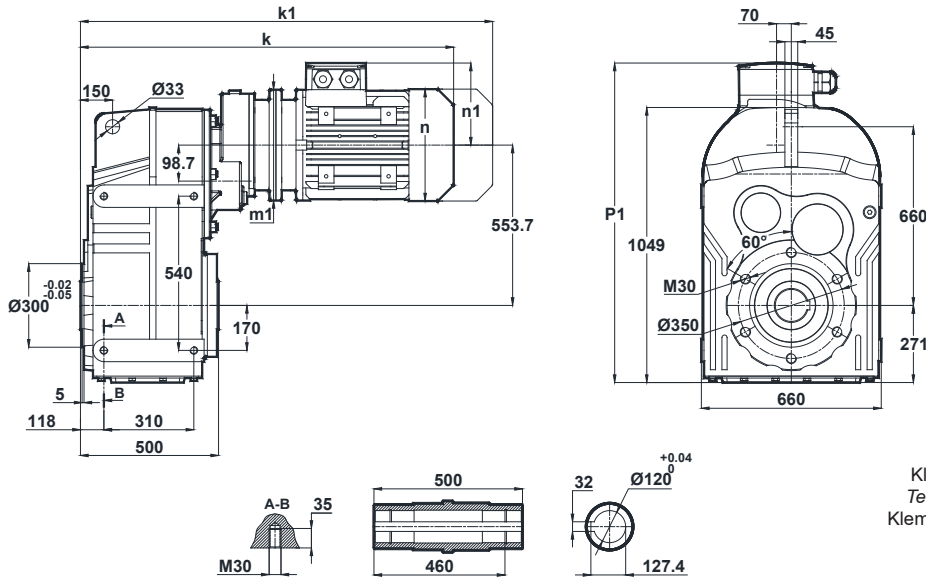

Klemens Pozisyonları  
Terminal Box Positions  
Klemmenkasten Positionen

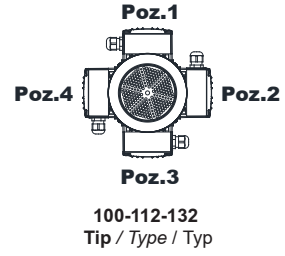

	100L/B5	112M/B5	132S/B5 132S/B14	132M/B5 132M/B14
k	990	1011	1110	1110
k1	1109.5	1115.5	1240	1240
n / n1	193 / 147	215 / 158	257 / 179	257 / 179
m1 (B5)	250	250	300	300
m1 (B14)	-	-	200	200
p1	-	-	-	-

DV974.01

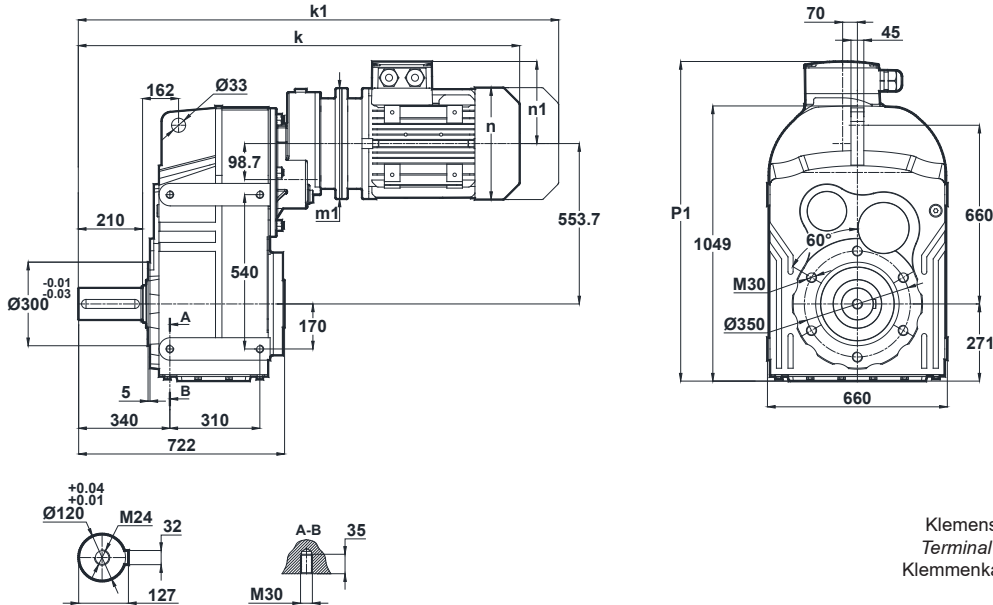

Klemens Pozisyonları  
Terminal Box Positions  
Klemmenkasten Positionen

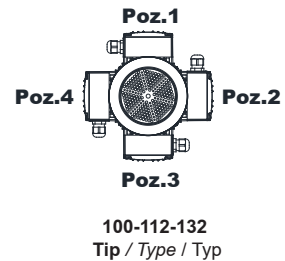

	100L/B5	112M/B5	132S/B5 132S/B14	132M/B5 132M/B14
k	1212	1233	1332	1332
k1	1331.5	1337.5	1462	1462
n / n1	193 / 147	215 / 158	257 / 179	257 / 179
m1 (B5)	250	250	300	300
m1 (B14)	-	-	200	200
p1	-	-	-	-

"k1" ölçüsü frenli redüktörlere aittir.  
Dimensions "k1" is for motors with brake.  
Maße "k1" ist für Bremsenmotoren.

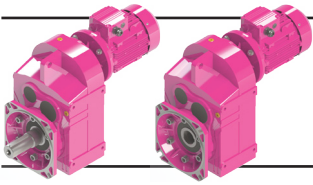

# Ölçü Sayfaları Dimension Pages Abmessungsseiten

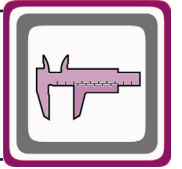

Mil ucu çektirme deliği DIN 332 sayfa 2 / Tapped center hole according to DIN 332, sheet 2 / Zentrierung mit Gewinde nach DIN 332, Blatt 2

## DV974.02

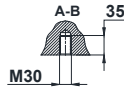
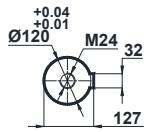
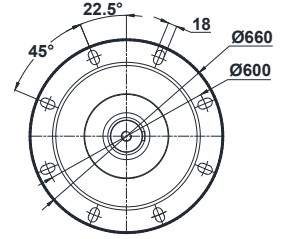
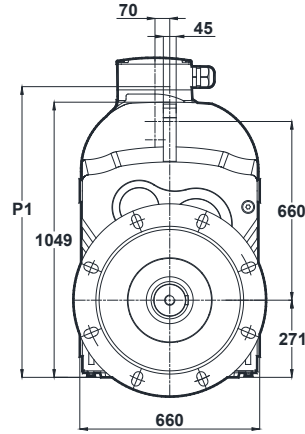
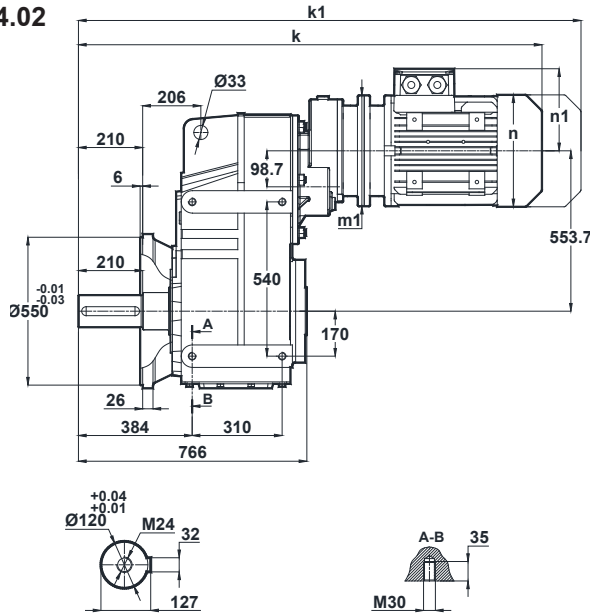

	100L/B5	112M/B5	132S/B5 132S/B14	132M/B5 132M/B14
k	1256	1277	1376	1376
k1	1375.5	1381.5	1506	1506
n / n1	193 / 147	215 / 158	257 / 179	257 / 179
m1 (B5)	250	250	300	300
m1 (B14)	-	-	200	200
p1	-	-	-	-

Klemens Pozisyonları  
Terminal Box Positions  
Klemmenkasten Positionen

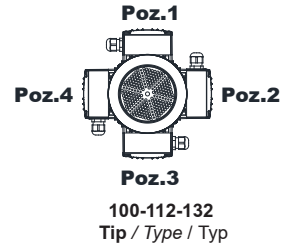

## DV974.03

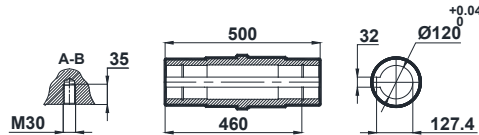
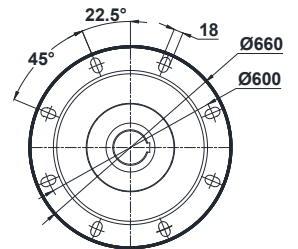
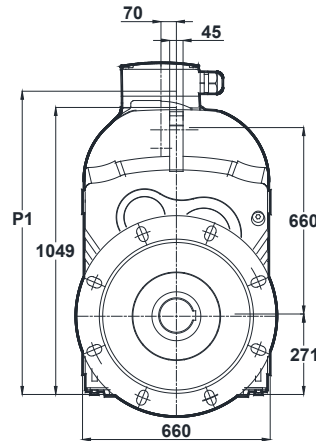
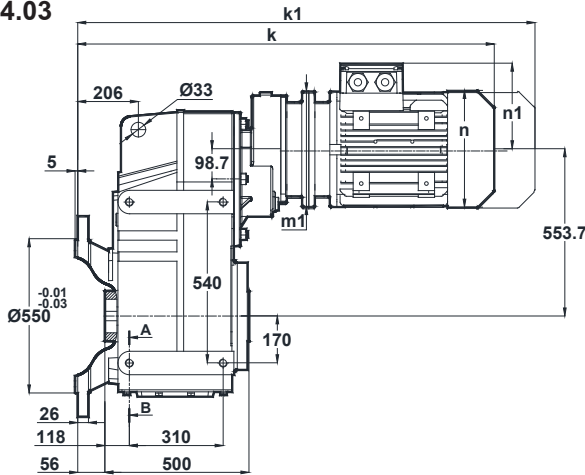

	100L/B5	112M/B5	132S/B5 132S/B14	132M/B5 132M/B14
k	1046	1067	1166	1166
k1	1165.5	1171.5	1296	1296
n / n1	193 / 147	215 / 158	257 / 179	257 / 179
m1 (B5)	250	250	300	300
m1 (B14)	-	-	200	200
p1	-	-	-	-

Klemens Pozisyonları  
Terminal Box Positions  
Klemmenkasten Positionen

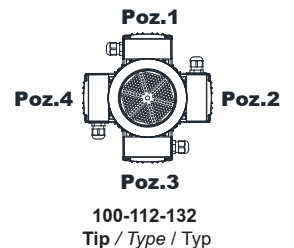

"k1" ölçüsü frenli redüktörlere aittir.  
Dimensions "k1" is for motors with brake.  
Maße "k1" ist für Bremsenmotoren.

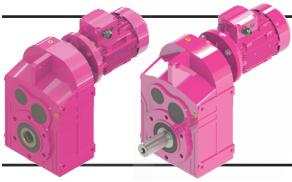

# Ölçü Sayfaları Dimension Pages Abmessungsseiten

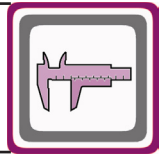

Mil ucu çektirme deliği DIN 332 sayfa 2 / Tapped center hole according to DIN 332, sheet 2 / Zentrierung mit Gewinde nach DIN 332, Blatt 2

DV975.00

DV976.00

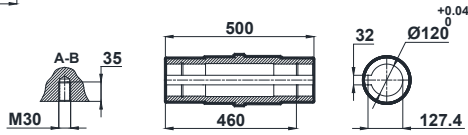
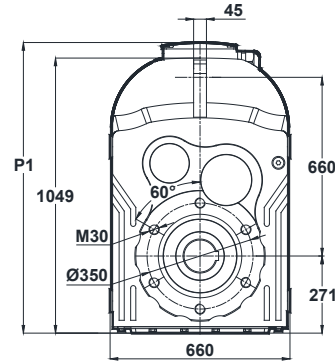
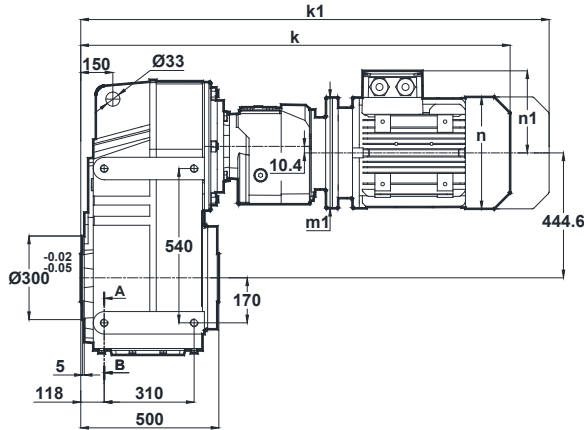

Klemens Pozisyonları  
Terminal Box Positions  
Klemmenkasten Positionen

	80/B5	90S/B5 90S/B14	90L/B5 90L/B14	100L/B5 100L/B14
k	1050	1091	1091	1145
k1	1143	1195.5	1195.5	1264.5
n / n1	155 / 121	176 / 132	176 / 132	193 / 147
m1 (B5)	200	200	200	250
m1 (B14)	-	140	140	160
p1	-	-	-	-

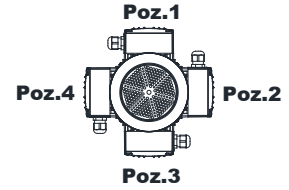

80-90-100  
Tip / Type / Typ

DV975.01

DV976.01

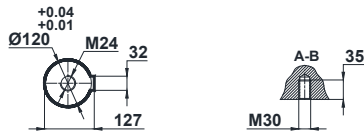
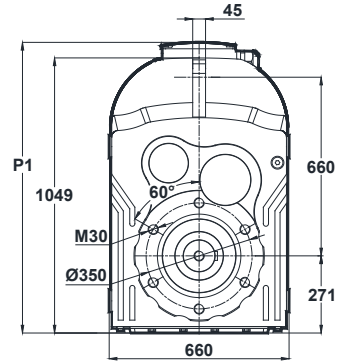
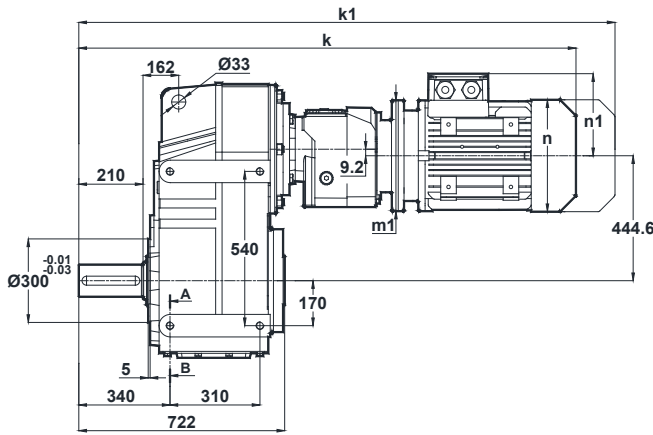

Klemens Pozisyonları  
Terminal Box Positions  
Klemmenkasten Positionen

	80/B5	90S/B5 90S/B14	90L/B5 90L/B14	100L/B5 100L/B14
k	1272	1313	1313	1367
k1	1365	1417.5	1417.5	1486.5
n / n1	155 / 121	176 / 132	176 / 132	193 / 147
m1 (B5)	200	200	200	250
m1 (B14)	-	140	140	160
p1	-	-	-	-

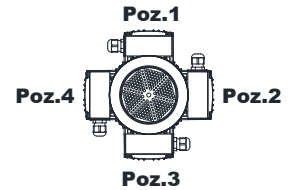

80-90-100  
Tip / Type / Typ

"k1" ölçüsü frenli redüktörlere aittir.  
Dimensions "k1" is for motors with brake.  
Maße "k1" ist für Bremsenmotoren.

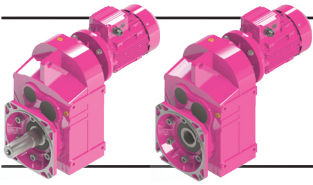

# Ölçü Sayfaları

## Dimension Pages

### Abmessungsseiten

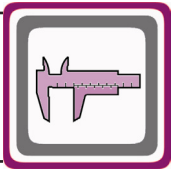

Mil ucu çektirme deliği DIN 332 sayfa 2 / Tapped center hole according to DIN 332, sheet 2 / Zentrierung mit Gewinde nach DIN 332, Blatt 2

DV975.02  
DV976.02

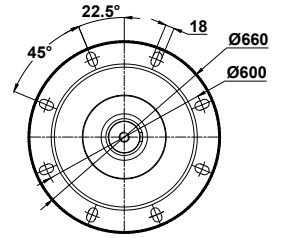
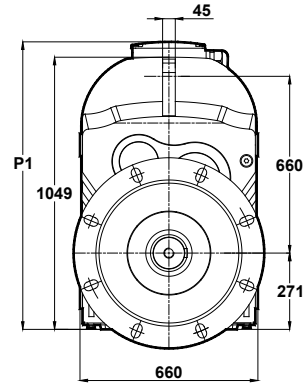
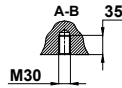
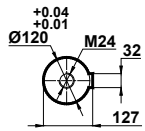
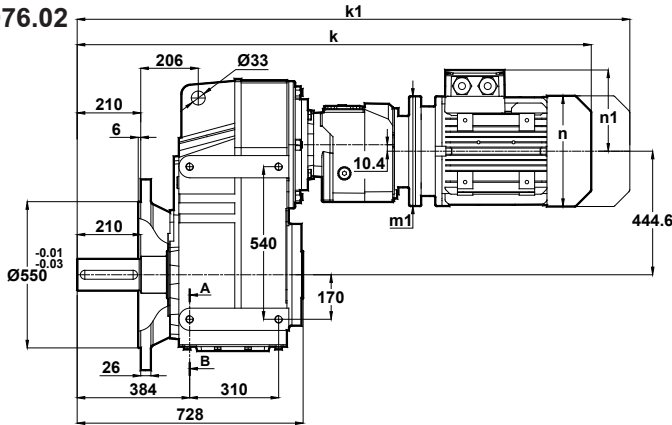

Klemens Pozisyonları  
Terminal Box Positions  
Klemmenkasten Positionen

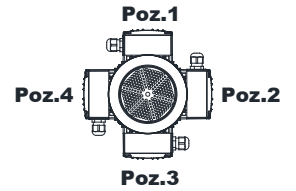

80-90-100  
Tip / Type / Typ

	80/B5	90S/B5 90S/B14	90L/B5 90L/B14	100L/B5 100L/B14
k	1316	1357	1357	1411
k1	1409	1461.5	1461.5	1530.5
n / n1	155 / 121	176 / 132	176 / 132	193 / 147
m1 (B5)	200	200	200	250
m1 (B14)	-	140	140	160
p1	-	-	-	-

DV975.03  
DV976.03

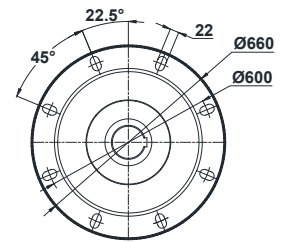
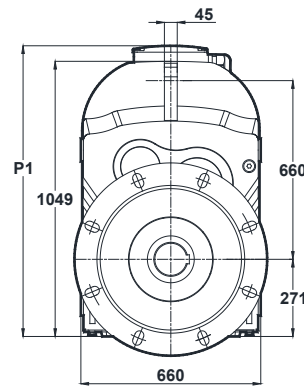
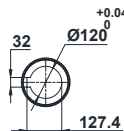
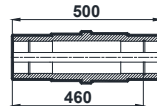
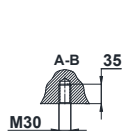
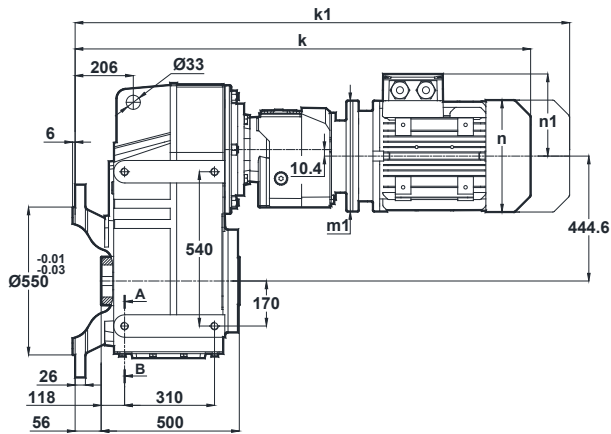

Klemens Pozisyonları  
Terminal Box Positions  
Klemmenkasten Positionen

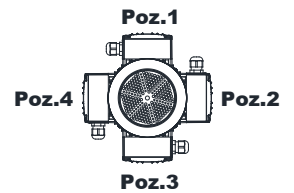

80-90-100  
Tip / Type / Typ

	80/B5	90S/B5 90S/B14	90L/B5 90L/B14	100L/B5 100L/B14
k	1106	1147	1147	1201
k1	1199	1251.5	1251.5	1320.5
n / n1	155 / 121	176 / 132	176 / 132	193 / 147
m1 (B5)	200	200	200	250
m1 (B14)	-	140	140	160
p1	-	-	-	-

"k1" ölçüsü frenli redüktörlere aittir.  
Dimensions "k1" is for motors with brake.  
Maße "k1" ist für Bremsenmotoren.



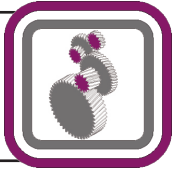
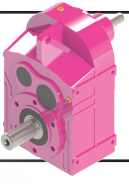

# Güç ve Devir Tabloları

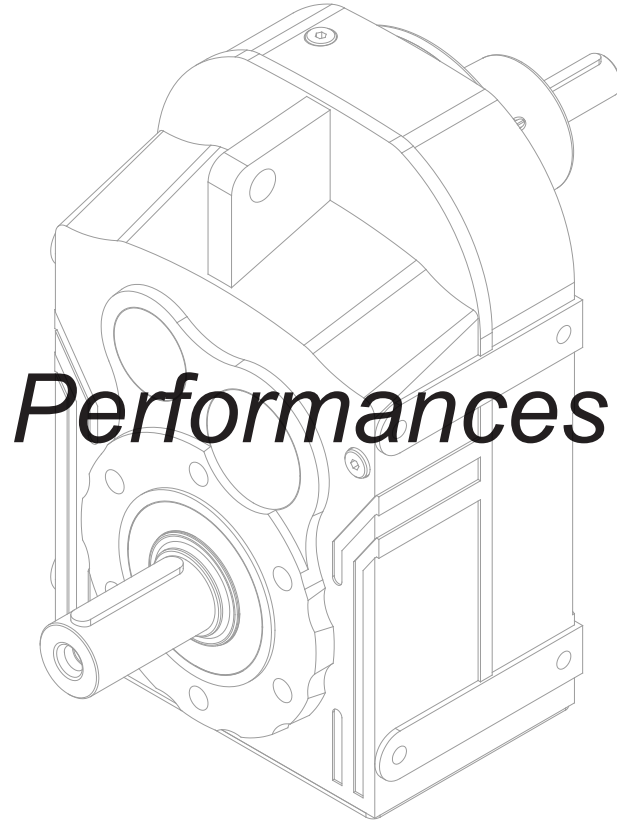

*Performances*

**Leistung und  
Drehzahlübersicht**

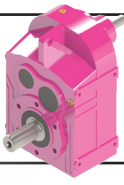

# D Serisi Motorsuz Güç Devir Sayfaları

## D Series Gear Units Performance Tables

### D Serien Getriebe Leistung und Drehzahlübersicht

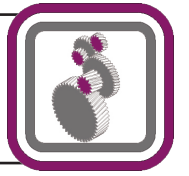

Anma Momenti <i>Nominal Torques</i> Nenn-drehmomente Ma [Nm] (n1=1450rpm)	Çevrim Oranı	Çıkış Devri	Tipi	Pe= Nominal Güç [kW] (Servis Faktörü fs=1,0 için)						Güv. Rad.Yük Çıkış	Güv.Rad.Yük Giriş	Ağırlık	Ölçü Sayfası
	Ratio	Output Speeds		Type	Pe= Nominal Power [kW] (For Service Factor fs=1,0)						Per.O.Loads (Output)		
	Übersetzung	Abtriebs-drehzahlen	Typ	Giriş devri[d/d] / Input speed[rpm] / Antriebsdrehzahl[upm]						Zul.Querkräfte (Abtrieb)	Zul.Querkräfte (Antrieb)	Gewicht	Maße Seite
	i	n2 [r.p.m] (n1=1450rpm)		n1=2900	n1=1450	n1=950	n1=725	n1=475	n1=360	Fqam [N] (n1=1450rpm)	Fqem [N] (n1=1450rpm)	[kg]	
<b>150</b>	5.77	251	<b>DT072</b>	8.1	<b>4.1</b>	2.7	2.1	1.3	1.0	115	-	8	264
<b>150</b>	6.91	210		6.8	<b>3.4</b>	2.2	1.7	1.1	0.86	312	-		
<b>150</b>	8.18	177		5.8	<b>2.9</b>	1.9	1.5	0.95	0.72	415	-		
<b>150</b>	8.76	166		5.4	<b>2.7</b>	1.8	1.4	0.89	0.68	461	-		
<b>150</b>	10.53	138		4.5	<b>2.3</b>	1.5	1.1	0.74	0.56	739	-		
<b>150</b>	12.61	115		3.7	<b>1.9</b>	1.2	0.95	0.62	0.47	873	-		
<b>150</b>	14.92	97		3.2	<b>1.6</b>	1.05	0.80	0.53	0.40	1006	-		
<b>150</b>	15.97	91		3.0	<b>1.5</b>	0.98	0.75	0.49	0.37	1062	-		
<b>150</b>	18.09	80		2.6	<b>1.3</b>	0.9	0.66	0.43	0.33	1168	-		
<b>150</b>	21.12	69		2.3	<b>1.1</b>	0.7	0.57	0.37	0.28	1306	-		
<b>150</b>	25.01	58		1.9	<b>0.96</b>	0.6	0.48	0.32	0.27	1465	-		
<b>150</b>	27.64	52		1.7	<b>0.87</b>	0.57	0.44	0.29	0.24	1563	-		
<b>150</b>	30.71	47		1.6	<b>0.78</b>	0.51	0.39	0.26	0.22	1670	-		
<b>150</b>	36.86	39	1.3	<b>0.65</b>	0.43	0.33	0.24	0.18	1865	-			
<b>150</b>	35.43	41	<b>DT073</b>	1.4	<b>0.69</b>	0.45	0.35	0.25	0.19	1821	604	9	264
<b>150</b>	38.18	38		1.3	<b>0.64</b>	0.42	0.32	0.23	0.18	1904	609		
<b>150</b>	44.60	33		1.1	<b>0.55</b>	0.36	0.28	0.20	0.15	2081	623		
<b>150</b>	52.62	28		0.93	<b>0.47</b>	0.31	0.26	0.17	0.13	2280	635		
<b>150</b>	62.94	23		0.78	<b>0.39</b>	0.26	0.22	0.14	0.11	2508	647		
<b>150</b>	67.62	21		0.72	<b>0.36</b>	0.27	0.20	0.13	0.10	2604	732		
<b>150</b>	72.87	20		0.67	<b>0.34</b>	0.25	0.19	0.12	0.09	2706	736		
<b>150</b>	85.12	17		0.58	<b>0.29</b>	0.21	0.16	0.11	0.08	2925	743		
<b>150</b>	100.43	14		0.50	<b>0.28</b>	0.18	0.14	0.09	0.07	3173	749		
<b>150</b>	120.11	12		0.42	<b>0.23</b>	0.15	0.12	0.08	0.06	3456	755		
<b>150</b>	133.46	11		0.38	<b>0.21</b>	0.14	0.11	0.07	0.05	3630	763		
<b>150</b>	146.60	10		0.35	<b>0.19</b>	0.13	0.10	0.06	0.05	3791	764		
<b>150</b>	180.05	8.1		0.28	<b>0.16</b>	0.10	0.08	0.05	0.04	4162	767		
<b>145</b>	4,86	298	<b>DT172</b>	7,4	<b>4,7</b>	3,5	2,8	2,1	1,6	2352	-	13	266
<b>160</b>	5,88	247		6,9	<b>4,3</b>	3,2	2,6	1,8	1,3	2418	-		
<b>170</b>	6,72	216		6,3	<b>4,0</b>	3,0	2,4	1,5	1,2	2484	-		
<b>180</b>	7,74	187		5,9	<b>3,7</b>	2,7	2,0	1,3	1,0	2575	-		
<b>200</b>	9,54	152		6,1	<b>3,3</b>	2,2	1,7	1,1	0,83	2964	-		
<b>200</b>	11,54	126		5,4	<b>2,7</b>	1,8	1,4	0,90	0,68	3346	-		
<b>200</b>	13,19	110		4,8	<b>2,4</b>	1,6	1,2	0,79	0,60	3630	-		
<b>200</b>	15,18	96		4,2	<b>2,1</b>	1,4	1,0	0,69	0,52	3943	-		
<b>200</b>	17,86	81		3,5	<b>1,8</b>	1,2	0,89	0,59	0,44	4322	-		
<b>200</b>	19,04	76		3,3	<b>1,7</b>	1,1	0,84	0,55	0,42	4477	-		
<b>200</b>	21,79	67		2,9	<b>1,5</b>	0,96	0,73	0,48	0,36	4816	-		
<b>200</b>	25,24	57		2,5	<b>1,3</b>	0,83	0,63	0,42	0,32	5202	-		
<b>200</b>	29,67	49		2,1	<b>1,1</b>	0,71	0,54	0,35	0,27	5500	-		
<b>200</b>	27,18	53	<b>DT173</b>	2,2	<b>1,2</b>	0,78	0,60	0,39	0,30	5404	509	14	266
<b>200</b>	31,52	46		2,0	<b>1,0</b>	0,67	0,52	0,34	0,26	5500	531		
<b>200</b>	37,75	38		1,7	<b>0,86</b>	0,57	0,43	0,28	0,24	5500	559		
<b>200</b>	44,66	32		1,4	<b>0,73</b>	0,48	0,37	0,27	0,20	5500	575		
<b>200</b>	47,81	30		1,4	<b>0,68</b>	0,45	0,34	0,25	0,19	5500	581		
<b>200</b>	51,88	28		1,2	<b>0,63</b>	0,41	0,32	0,23	0,17	5500	679		
<b>200</b>	60,16	24		1,1	<b>0,54</b>	0,36	0,27	0,20	0,15	5500	690		
<b>200</b>	72,04	20		0,90	<b>0,46</b>	0,30	0,25	0,17	0,13	5500	705		
<b>200</b>	85,23	17		0,77	<b>0,39</b>	0,25	0,22	0,14	0,11	5500	713		
<b>200</b>	91,25	16		0,72	<b>0,36</b>	0,26	0,20	0,13	0,10	5500	716		
<b>200</b>	103,34	14		0,64	<b>0,32</b>	0,23	0,18	0,12	0,09	5500	720		
<b>200</b>	120,64	12		0,55	<b>0,28</b>	0,20	0,15	0,10	0,08	5500	725		
<b>200</b>	142,89	10		0,47	<b>0,26</b>	0,17	0,13	0,09	0,07	5500	730		
<b>275</b>	4,98	291	<b>DT272</b>	14	<b>8,6</b>	6,4	5,2	4,0	3,3	9105	-	21	268
<b>295</b>	5,82	249		13	<b>8,0</b>	6,0	4,8	3,7	3,0	9478	-		
<b>320</b>	6,84	212		12	<b>7,3</b>	5,5	4,4	3,4	2,6	9865	-		
<b>395</b>	8,67	167		12	<b>7,2</b>	5,4	4,1	2,7	2,0	10462	-		
<b>425</b>	10,11	143		11	<b>6,6</b>	4,6	3,5	2,3	1,8	10872	-		

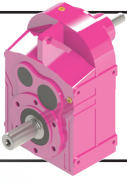

# D Serisi Motorsuz Güç Devir Sayfaları

## D Series Gear Units Performance Tables

### D Serien Getriebe Leistung und Drehzahlübersicht



Anma Momenti <i>Nominal Torques</i> Nenn-drehmomente Ma [Nm] (n1=1450rpm)	Çevrim Oranı <i>Ratio</i> Übersetzung i	Çıkış Devri <i>Output Speeds</i> Abtriebs-drehzahlen n2 [r.p.m] (n1=1450rpm)	Tipi <i>Type</i> Typ	Pe= Nominal Güç [kW] (Servis Faktörü fs=1,0 için) <i>Pe= Nominal Power [kW] (For Service Factor fs=1,0)</i> Pe= NennLeistung [kW] (Bei Betriebsfaktor fs=1,0)						Güv. Rad.Yük Çıkış <i>Per.O.Loads (Output)</i> Zul.Querkräfte (Abtrieb) Fqam [N] (n1=1450rpm)	Güv.Rad.Yük Giriş <i>Per.O.Loads (Input)</i> Zul.Querkräfte (Antrieb) Fqem [N] (n1=1450rpm)	Ağırlık <i>Weight</i> Gewicht [kg]	Ölçü Sayfası <i>Dim. Page</i> Maße Seite
				Giriş devri[d/d] / Input speed[rpm] / Antriebsdrehzahl[upm]									
				n1=2900	n1=1450	n1=950	n1=725	n1=475	n1=360				
				<b>450</b>	11,90	122	<b>DT272</b>	10	<b>6,0</b>	3,9	3,0	2,0	1,5
<b>450</b>	14,14	103		8,9	<b>5,0</b>	3,3	2,5	1,7	1,3	12000	-		
<b>450</b>	16,00	91		8,4	<b>4,4</b>	2,9	2,2	1,5	1,1	12000	-		
<b>450</b>	18,25	79		7,7	<b>3,9</b>	2,6	2,0	1,3	0,98	12000	-		
<b>450</b>	21,33	68		6,6	<b>3,3</b>	2,2	1,7	1,1	0,83	12000	-		
<b>450</b>	22,67	64		6,3	<b>3,1</b>	2,1	1,6	1,0	0,79	12000	-		
<b>450</b>	25,78	56		5,5	<b>2,8</b>	1,8	1,4	0,91	0,69	12000	-		
<b>440</b>	25,44	57	<b>DT273</b>	4,4	<b>2,8</b>	1,9	1,4	0,94	0,71	12350	189	22	268
<b>450</b>	30,34	48		3,9	<b>2,4</b>	1,6	1,2	0,79	0,60	12000	342		
<b>450</b>	36,38	40		3,5	<b>2,0</b>	1,3	1,0	0,66	0,50	12000	525		
<b>450</b>	42,22	34		3,0	<b>1,7</b>	1,1	0,86	0,57	0,43	12000	804		
<b>450</b>	50,36	29		2,7	<b>1,4</b>	0,95	0,72	0,48	0,36	12000	833		
<b>450</b>	60,39	24		2,4	<b>1,2</b>	0,79	0,61	0,40	0,30	12000	857		
<b>450</b>	73,03	20		2,0	<b>1,0</b>	0,66	0,50	0,33	0,25	12000	879		
<b>450</b>	83,46	17		1,7	<b>0,88</b>	0,58	0,44	0,29	0,24	12000	892		
<b>450</b>	96,09	15		1,5	<b>0,76</b>	0,50	0,38	0,25	0,21	12000	903		
<b>450</b>	113,02	13		1,3	<b>0,65</b>	0,43	0,33	0,24	0,18	12000	914		
<b>450</b>	120,49	12		1,2	<b>0,61</b>	0,40	0,31	0,22	0,17	12000	918		
<b>450</b>	137,94	11		1,1	<b>0,54</b>	0,35	0,27	0,20	0,15	12000	926		
<b>450</b>	150,45	9,6	<b>DT275</b>	1,0	<b>0,51</b>	0,33	0,25	0,18	0,14	12000	686	27	270
<b>450</b>	181,94	8,0		0,84	<b>0,42</b>	0,28	0,23	0,15	0,12	12000	718		
<b>450</b>	207,93	7,0		0,74	<b>0,37</b>	0,27	0,20	0,13	0,10	12000	737		
<b>450</b>	214,95	6,7		0,71	<b>0,36</b>	0,26	0,20	0,13	0,10	12000	735		
<b>450</b>	251,08	5,8		0,61	<b>0,31</b>	0,22	0,17	0,11	0,08	12000	742		
<b>450</b>	331,04	4,4		0,51	<b>0,26</b>	0,19	0,14	0,09	0,07	12000	789		
<b>450</b>	356,74	4,1		0,48	<b>0,24</b>	0,17	0,13	0,09	0,07	12000	788		
<b>450</b>	416,71	3,5		0,41	<b>0,20</b>	0,15	0,11	0,07	0,06	12000	793		
<b>450</b>	497,10	2,9		0,34	<b>0,17</b>	0,13	0,10	0,06	0,05	12000	805		
<b>450</b>	596,04	2,4		0,29	<b>0,14</b>	0,10	0,08	0,05	0,04	12000	816		
<b>450</b>	720,79	2,0		0,26	<b>0,12</b>	0,09	0,07	0,04	0,03	12000	825		
<b>450</b>	823,76	1,8		0,23	<b>0,10</b>	0,08	0,06	0,04	0,03	12000	831		
<b>450</b>	948,41	1,5		0,20	<b>0,09</b>	0,07	0,05	0,03	0,02	12000	836		
<b>450</b>	1115,51	1,3		0,17	<b>0,08</b>	0,06	0,04	0,03	0,02	12000	841		
<b>450</b>	1189,30	1,2		0,16	<b>0,07</b>	0,05	0,04	0,03	0,02	12000	843		
<b>450</b>	1215,13	1,2	<b>DT276</b>	0,16	<b>0,07</b>	0,05	0,04	0,03	0,02	12000	843	29	270
<b>450</b>	1456,98	1,0		0,13	<b>0,06</b>	0,04	0,03	0,02	0,02	12000	848		
<b>450</b>	1761,93	0,82		0,11	<b>0,05</b>	0,04	0,03	0,02	0,01	12000	851		
<b>450</b>	2013,64	0,72		0,10	<b>0,04</b>	0,03	0,02	0,02	0,01	12000	854		
<b>450</b>	2318,33	0,63		0,08	<b>0,04</b>	0,03	0,02	0,01	0,01	12000	856		
<b>450</b>	2726,80	0,53		0,07	<b>0,03</b>	0,02	0,02	0,01	0,01	12000	858		
<b>450</b>	2907,19	0,50		0,07	<b>0,03</b>	0,02	0,02	0,01	0,01	12000	858		
<b>260</b>	3,92	370	<b>DT282</b>	17	<b>10</b>	7,7	6,2	4,8	3,9	11041	-	31	272
<b>280</b>	4,52	321		16	<b>9,7</b>	7,3	5,8	4,5	3,6	11465	-		
<b>300</b>	5,22	278		15	<b>9,0</b>	6,8	5,5	4,2	3,4	11910	-		
<b>315</b>	5,74	253		14	<b>8,6</b>	6,5	5,2	4,0	3,3	12204	-		
<b>340</b>	6,65	218		13	<b>8,0</b>	6,0	4,9	3,7	3,0	12674	-		
<b>380</b>	7,09	205		14	<b>8,4</b>	6,3	5,1	3,9	3,2	12921	-		
<b>410</b>	8,19	177		13	<b>7,9</b>	5,9	4,8	3,6	2,9	13401	-		
<b>440</b>	9,45	153		12	<b>7,3</b>	5,5	4,4	3,3	2,5	13665	-		
<b>460</b>	10,38	140		11	<b>7,0</b>	5,2	4,2	3,0	2,3	13274	-		
<b>490</b>	12,03	121		10	<b>6,4</b>	4,8	3,9	2,6	2,0	12625	-		
<b>525</b>	14,06	103		10	<b>5,9</b>	4,4	3,4	2,2	1,7	11765	-		
<b>565</b>	16,62	87		8,7	<b>5,4</b>	3,7	2,9	1,9	1,4	10610	-		
<b>590</b>	18,73	77		8,1	<b>5,0</b>	3,3	2,5	1,7	1,3	9780	-		
<b>600</b>	21,28	68		7,5	<b>4,5</b>	2,9	2,2	1,5	1,1	9200	-		
<b>600</b>	24,79	58		6,8	<b>3,8</b>	2,5	1,9	1,3	0,96	9200	-		
<b>600</b>	29,85	49		6,0	<b>3,2</b>	2,1	1,6	1,1	0,80	9200	-		

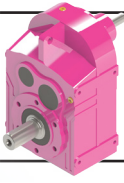

# D Serisi Motorsuz Güç Devir Sayfaları

## D Series Gear Units Performance Tables

### D Serien Getriebe Leistung und Drehzahlübersicht

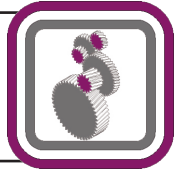

Anma Momenti <i>Nominal Torques</i> Nenn-drehmomente Ma [Nm] (n1=1450rpm)	Çevrim Oranı	Çıkış Devri	Tipi	Pe= Nominal Güç [kW] (Servis Faktörü fs=1,0 için)						Güv. Rad.Yük Çıkış	Güv.Rad.Yük Giriş	Ağırlık	Ölçü Sayfası
	Ratio	Output Speeds		Type	Pe= Nominal Power [kW] (For Service Factor fs=1,0)						Per.O.Loads (Output)		
	Übersetzung	Abtriebs-drehzahlen	Typ	Giriş devri[d/d] / Input speed[rpm] / Antriebsdrehzahl[upm]						Zul.Querkräfte (Abtrieb)	Zul.Querkräfte (Antrieb)	Gewicht	Maße Seite
	i	n2 [r.p.m] (n1=1450rpm)		n1=2900	n1=1450	n1=950	n1=725	n1=475	n1=360	Fqam [N] (n1=1450rpm)	Fqem [N] (n1=1450rpm)	[kg]	
<b>590</b>	30,28	48	<b>DT283</b>	4,9	<b>3,1</b>	2,1	1,6	1,1	0,80	9780	1309	32	272
<b>600</b>	35,35	41		4,5	<b>2,7</b>	1,8	1,4	0,90	0,69	9200	1340		
<b>600</b>	41,23	35		4,0	<b>2,3</b>	1,5	1,2	0,77	0,59	9200	1379		
<b>600</b>	45,56	32		3,8	<b>2,1</b>	1,4	1,1	0,70	0,53	9200	1398		
<b>600</b>	53,18	27		3,4	<b>1,8</b>	1,2	0,92	0,60	0,46	9200	1424		
<b>600</b>	62,55	23		3,1	<b>1,6</b>	1,0	0,78	0,51	0,39	9200	1447		
<b>600</b>	74,36	19		2,6	<b>1,3</b>	0,86	0,66	0,43	0,33	9200	1468		
<b>600</b>	84,12	17		2,3	<b>1,2</b>	0,76	0,58	0,38	0,29	9200	1481		
<b>600</b>	95,92	15		2,0	<b>1,0</b>	0,67	0,51	0,34	0,26	9200	1492		
<b>600</b>	112,15	13		1,7	<b>0,87</b>	0,57	0,44	0,29	0,24	9200	1505		
<b>600</b>	119,16	12		1,6	<b>0,82</b>	0,54	0,41	0,27	0,23	9200	1509		
<b>600</b>	135,52	11		1,4	<b>0,73</b>	0,48	0,37	0,27	0,20	9200	1517		
<b>600</b>	127,94	11	<b>DT285</b>	1,6	<b>0,79</b>	0,52	0,39	0,26	0,22	9200	582	35	274
<b>600</b>	137,88	11		1,5	<b>0,73</b>	0,48	0,37	0,27	0,20	9200	590		
<b>600</b>	161,05	9,0		1,3	<b>0,63</b>	0,41	0,31	0,23	0,17	9200	606		
<b>600</b>	196,84	7,4		1,0	<b>0,52</b>	0,34	0,26	0,19	0,14	9200	683		
<b>600</b>	212,12	6,8		0,96	<b>0,48</b>	0,31	0,27	0,17	0,13	9200	688		
<b>600</b>	244,26	5,9		0,83	<b>0,42</b>	0,27	0,23	0,15	0,12	9200	719		
<b>600</b>	263,22	5,5		0,77	<b>0,39</b>	0,25	0,22	0,14	0,11	9200	723		
<b>600</b>	277,21	5,2		0,73	<b>0,37</b>	0,27	0,20	0,13	0,10	9200	737		
<b>600</b>	298,73	4,9		0,68	<b>0,34</b>	0,25	0,19	0,12	0,09	9200	741		
<b>600</b>	348,95	4,2		0,59	<b>0,29</b>	0,21	0,16	0,11	0,08	9200	748		
<b>600</b>	406,99	3,6		0,50	<b>0,25</b>	0,18	0,14	0,09	0,07	9200	765		
<b>600</b>	449,72	3,2		0,50	<b>0,25</b>	0,18	0,14	0,09	0,07	9200	775		
<b>600</b>	524,87	2,8		0,43	<b>0,22</b>	0,16	0,12	0,08	0,06	9200	788		
<b>600</b>	617,37	2,3		0,37	<b>0,18</b>	0,13	0,10	0,07	0,05	9200	801		
<b>600</b>	733,99	2,0		0,31	<b>0,15</b>	0,11	0,09	0,06	0,04	9200	812		
<b>600</b>	830,25	1,7		0,27	<b>0,14</b>	0,10	0,08	0,05	0,04	9200	818		
<b>600</b>	936,69	1,5	0,27	<b>0,12</b>	0,09	0,07	0,04	0,03	9200	824			
<b>600</b>	1003,22	1,4	<b>DT286</b>	0,26	<b>0,12</b>	0,08	0,06	0,04	0,03	9200	827	36	274
<b>600</b>	1170,08	1,2		0,22	<b>0,10</b>	0,07	0,06	0,04	0,03	9200	833		
<b>600</b>	1292,94	1,1		0,20	<b>0,09</b>	0,07	0,05	0,03	0,02	9200	837		
<b>600</b>	1509,00	0,96		0,17	<b>0,08</b>	0,06	0,04	0,03	0,02	9200	841		
<b>600</b>	1774,93	0,82		0,15	<b>0,07</b>	0,05	0,04	0,02	0,02	9200	845		
<b>600</b>	2110,22	0,69		0,12	<b>0,06</b>	0,04	0,03	0,02	0,02	9200	849		
<b>600</b>	2386,97	0,61		0,11	<b>0,05</b>	0,04	0,03	0,02	0,01	9200	852		
<b>600</b>	2692,99	0,54		0,10	<b>0,04</b>	0,03	0,02	0,02	0,01	9200	854		
<b>600</b>	3368,37	0,43		0,08	<b>0,03</b>	0,03	0,02	0,01	0,01	9200	853		
<b>600</b>	3800,21	0,38		0,07	<b>0,03</b>	0,02	0,02	0,01	0,01	9200	855		
<b>390</b>	3,65	397	<b>DT372</b>	-	<b>17</b>	12	10	7,8	6,3	10152	-	65	276
<b>435</b>	4,42	328		25	<b>15</b>	11	9,3	7,1	5,8	10601	-		
<b>465</b>	5,05	287		23	<b>14</b>	10	8,7	6,7	5,4	10944	-		
<b>495</b>	5,79	250		22	<b>13</b>	10	8,2	6,2	5,1	11333	-		
<b>530</b>	6,69	217		20	<b>12</b>	9,3	7,5	5,8	4,7	11745	-		
<b>640</b>	7,42	195		-	<b>14</b>	10	8,2	5,7	4,3	12029	-		
<b>700</b>	8,98	161		20	<b>12</b>	9,2	7,2	4,7	3,6	12606	-		
<b>745</b>	10,25	141		19	<b>11</b>	8,3	6,3	4,1	3,1	13016	-		
<b>795</b>	11,77	123		17	<b>11</b>	7,2	5,5	3,6	2,7	12881	-		
<b>820</b>	13,60	107		16	<b>9,5</b>	6,2	4,8	3,1	2,4	11800	-		
<b>820</b>	14,74	98		15	<b>8,8</b>	5,8	4,4	2,9	2,2	11800	-		
<b>820</b>	17,65	82		14	<b>7,3</b>	4,8	3,7	2,4	1,8	11800	-		
<b>820</b>	20,10	72		13	<b>6,4</b>	4,2	3,2	2,1	1,6	11800	-		
<b>820</b>	22,46	65		11	<b>5,8</b>	3,8	2,9	1,9	1,4	11800	-		
<b>820</b>	25,42	57		10	<b>5,1</b>	3,4	2,6	1,7	1,3	11800	-		
<b>645</b>	23,58	61	<b>DT373</b>	6,8	<b>4,4</b>	3,3	2,8	1,8	1,4	16231	1104	67	276
<b>680</b>	27,53	53		6,2	<b>3,9</b>	3,0	2,4	1,6	1,2	15571	1123		
<b>720</b>	32,11	45		5,6	<b>3,6</b>	2,7	2,1	1,4	1,0	14739	1142		
<b>745</b>	35,49	41		5,3	<b>3,4</b>	2,4	1,9	1,2	0,93	14167	1149		

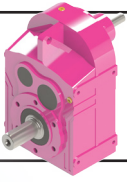

# D Serisi Motorsuz Güç Devir Sayfaları

## D Series Gear Units Performance Tables

### D Serien Getriebe Leistung und Drehzahlübersicht



Anma Momenti <i>Nominal Torques</i> Nenn-drehmomente Ma [Nm] (n1=1450rpm)	Çevrim Oranı <i>Ratio</i> Übersetzung i	Çıkış Devri <i>Output Speeds</i> Abtriebs-drehzahlen n2 [r.p.m] (n1=1450rpm)	Tipi <i>Type</i> Typ	Pe= Nominal Güç [kW] (Servis Faktörü fs=1,0 için) <i>Pe= Nominal Power [kW] (For Service Factor fs=1,0)</i> Pe= NennLeistung [kW] (Bei Betriebsfaktor fs=1,0)						Güv. Rad.Yük Çıkış <i>Per.O.Loads (Output)</i> Zul.Querkräfte (Abtrieb) Fqam [N] (n1=1450rpm)	Güv.Rad.Yük Giriş <i>Per.O.Loads (Input)</i> Zul.Querkräfte (Antrieb) Fqem [N] (n1=1450rpm)	Ağırlık <i>Weight</i> Gewicht [kg]	Ölçü Sayfası <i>Dim. Page</i> Maße Seite
				Giriş devri[d/d] / Input speed[rpm] / Antriebsdrehzahl[upm]									
				n1=2900	n1=1450	n1=950	n1=725	n1=475	n1=360				
				<b>785</b>	41,42	35	<b>DT373</b>	4,8	<b>3,0</b>	2,1	1,6	1,0	0,80
<b>820</b>	52,30	28		4,0	<b>2,5</b>	1,7	1,3	0,83	0,63	11800	1343		
<b>820</b>	57,79	25		3,7	<b>2,3</b>	1,5	1,1	0,76	0,57	11800	1364		
<b>820</b>	67,45	21		3,4	<b>2,0</b>	1,3	1,0	0,65	0,49	11800	1392		
<b>820</b>	79,34	18		3,1	<b>1,7</b>	1,1	0,84	0,55	0,42	11800	1417		
<b>820</b>	94,32	15		2,7	<b>1,4</b>	0,93	0,71	0,47	0,35	11800	1440		
<b>820</b>	106,69	14		2,5	<b>1,2</b>	0,82	0,63	0,41	0,31	11800	1453		
<b>820</b>	121,67	12		2,2	<b>1,1</b>	0,72	0,55	0,36	0,28	11800	1466		
<b>820</b>	151,15	9,6		1,8	<b>0,89</b>	0,58	0,45	0,29	0,25	11800	1484		
<b>820</b>	171,89	8,4		1,6	<b>0,78</b>	0,51	0,39	0,26	0,22	11800	1492		
<b>820</b>	174,88	8,3	<b>DT375</b>	1,6	<b>0,79</b>	0,52	0,40	0,26	0,22	11800	569	75	278
<b>820</b>	204,28	7,1		1,4	<b>0,68</b>	0,45	0,34	0,25	0,19	11800	585		
<b>820</b>	249,67	5,8		1,1	<b>0,56</b>	0,37	0,28	0,20	0,15	11800	668		
<b>820</b>	269,05	5,4		1,0	<b>0,52</b>	0,34	0,26	0,19	0,14	11800	674		
<b>820</b>	309,82	4,7		0,90	<b>0,45</b>	0,30	0,25	0,16	0,12	11800	707		
<b>820</b>	333,87	4,3		0,84	<b>0,42</b>	0,27	0,23	0,15	0,12	11800	712		
<b>820</b>	351,62	4,1		0,79	<b>0,40</b>	0,26	0,22	0,14	0,11	11800	726		
<b>820</b>	378,91	3,8		0,74	<b>0,37</b>	0,27	0,20	0,13	0,10	11800	731		
<b>820</b>	442,60	3,3		0,63	<b>0,32</b>	0,23	0,18	0,12	0,09	11800	738		
<b>820</b>	516,22	2,8		0,54	<b>0,27</b>	0,20	0,15	0,10	0,07	11800	757		
<b>820</b>	570,43	2,5		0,54	<b>0,27</b>	0,20	0,15	0,10	0,08	11800	768		
<b>820</b>	665,75	2,2		0,47	<b>0,23</b>	0,17	0,13	0,09	0,06	11800	782		
<b>820</b>	783,07	1,9		0,40	<b>0,20</b>	0,14	0,11	0,07	0,05	11800	795		
<b>820</b>	930,99	1,6		0,33	<b>0,17</b>	0,12	0,09	0,06	0,05	11800	807		
<b>820</b>	1053,09	1,4		0,30	<b>0,15</b>	0,11	0,08	0,05	0,04	11800	814		
<b>820</b>	1188,10	1,2		0,26	<b>0,13</b>	0,10	0,07	0,05	0,04	11800	821		
<b>820</b>	1272,49	1,1	<b>DT376</b>	0,25	<b>0,13</b>	0,09	0,07	0,05	0,03	11800	824	76	278
<b>820</b>	1484,14	0,98		0,24	<b>0,11</b>	0,08	0,06	0,04	0,03	11800	830		
<b>820</b>	1639,97	0,88		0,22	<b>0,10</b>	0,07	0,05	0,04	0,03	11800	834		
<b>820</b>	1914,03	0,76		0,19	<b>0,08</b>	0,06	0,05	0,03	0,02	11800	839		
<b>820</b>	2251,32	0,64		0,16	<b>0,07</b>	0,05	0,04	0,03	0,02	11800	844		
<b>820</b>	2676,61	0,54		0,13	<b>0,06</b>	0,04	0,03	0,02	0,02	11800	848		
<b>820</b>	3027,64	0,48		0,12	<b>0,05</b>	0,04	0,03	0,02	0,01	11800	850		
<b>820</b>	3415,80	0,42		0,10	<b>0,05</b>	0,03	0,03	0,02	0,01	11800	852		
<b>820</b>	4272,46	0,34		0,08	<b>0,04</b>	0,03	0,02	0,01	0,01	11800	852		
<b>820</b>	4820,21	0,30		0,07	<b>0,03</b>	0,02	0,02	0,01	0,01	11800	854		
<b>915</b>	4,48	324	<b>DT472</b>	-	<b>32</b>	24	19	15	12	12929	-	103	280
<b>990</b>	5,26	276		-	<b>29</b>	22	17	13	11	13406	-		
<b>1070</b>	6,23	233		44	<b>27</b>	20	16	12	9,8	13945	-		
<b>1130</b>	6,71	216		43	<b>26</b>	20	16	11	9,1	14063	-		
<b>1190</b>	7,54	192		40	<b>25</b>	19	15	10	8,1	14464	-		
<b>1445</b>	8,93	162		-	<b>25</b>	18	14	9,0	6,8	15180	-		
<b>1550</b>	10,48	138		-	<b>23</b>	15	12	7,7	5,8	15771	-		
<b>1550</b>	12,40	117		34	<b>20</b>	13	10	6,5	4,9	16967	-		
<b>1550</b>	13,35	109		33	<b>18</b>	12	9,1	6,0	4,6	17000	-		
<b>1550</b>	15,02	97		31	<b>16</b>	11	8,1	5,3	4,1	17000	-		
<b>1550</b>	17,01	85		29	<b>14</b>	9,4	7,2	4,7	3,6	17000	-		
<b>1550</b>	19,11	76		25	<b>13</b>	8,4	6,4	4,2	3,2	17000	-		
<b>1550</b>	20,74	70		23	<b>12</b>	7,7	5,9	3,9	2,9	17000	-		
<b>1550</b>	24,54	59		20	<b>10</b>	6,5	5,0	3,3	2,5	17000	-		
<b>1130</b>	28,45	51	<b>DT473</b>	-	<b>6,2</b>	4,7	3,8	2,8	2,1	24931	1446	104	280
<b>1210</b>	34,28	42		-	<b>5,5</b>	4,2	3,4	2,3	1,8	23821	1467		
<b>1290</b>	41,50	35		7,8	<b>4,9</b>	3,7	3,0	1,9	1,5	22575	1486		
<b>1350</b>	47,37	31		7,1	<b>4,5</b>	3,4	2,6	1,7	1,3	21538	1494		
<b>1410</b>	54,35	27		6,5	<b>4,1</b>	3,0	2,3	1,5	1,1	20396	1502		
<b>1440</b>	61,85	23		5,8	<b>3,7</b>	2,6	2,0	1,3	0,99	19781	1671		
<b>1500</b>	70,59	21		5,3	<b>3,4</b>	2,3	1,7	1,1	0,87	18448	1679		
<b>1550</b>	81,00	18		4,9	<b>3,0</b>	2,0	1,5	1,0	0,76	17000	1691		

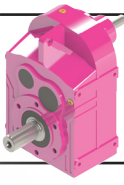

# D Serisi Motorsuz Güç Devir Sayfaları

## D Series Gear Units Performance Tables

### D Serien Getriebe Leistung und Drehzahlübersicht

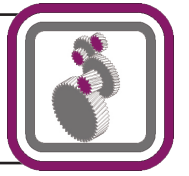

Anma Momenti <i>Nominal Torques</i> Nenn-drehmomente Ma [Nm] (n1=1450rpm)	Çevrim Oranı	Çıkış Devri	Tipi	Pe= Nominal Güç [kW] (Servis Faktörü fs=1,0 için)						Güv. Rad.Yük Çıkış	Güv.Rad.Yük Giriş	Ağırlık	Ölçü Sayfası
	Ratio	Output Speeds		Type	Pe= Nominal Power [kW] (For Service Factor fs=1,0)						Per.O.Loads (Output)		
	Übersetzung	Abtriebs-drehzahlen	Typ	Giriş devri[d/d] / Input speed[rpm] / Antriebsdrehzahl[upm]						Zul.Querkräfte (Antrieb)	Zul.Querkräfte (Antrieb)	Gewicht	Maße Seite
	i	n2 [r.p.m] (n1=1450rpm)		n1=2900	n1=1450	n1=950	n1=725	n1=475	n1=360	Fqam [N] (n1=1450rpm)	Fqem [N] (n1=1450rpm)	[kg]	
<b>1550</b>	95,87	15	<b>DT473</b>	4,4	<b>2,6</b>	1,7	1,3	0,84	0,64	17000	1724	104	280
<b>1550</b>	101,48	14		4,2	<b>2,4</b>	1,6	1,2	0,80	0,61	17000	1733		
<b>1550</b>	121,49	12		3,8	<b>2,0</b>	1,3	1,0	0,67	0,51	17000	1759		
<b>1550</b>	138,35	10		3,4	<b>1,8</b>	1,2	0,90	0,59	0,45	17000	1775		
<b>1550</b>	154,63	9,4		3,2	<b>1,6</b>	1,1	0,80	0,53	0,40	17000	1790		
<b>1550</b>	174,97	8,3		2,8	<b>1,4</b>	0,93	0,71	0,47	0,36	17000	1801		
<b>1550</b>	215,03	6,7		2,3	<b>1,2</b>	0,76	0,58	0,38	0,29	17000	1817		
<b>1550</b>	242,68	6,0		2,1	<b>1,0</b>	0,68	0,52	0,34	0,26	17000	1824		
<b>1550</b>	219,13	6,6	<b>DT474</b>	2,3	<b>1,2</b>	0,76	0,58	0,38	0,29	17000	1506	114	282
<b>1550</b>	252,29	5,7		2,0	<b>1,0</b>	0,66	0,51	0,33	0,25	17000	1521		
<b>1550</b>	296,74	4,9		1,7	<b>0,86</b>	0,56	0,43	0,28	0,24	17000	1534		
<b>1550</b>	316,37	4,6		1,6	<b>0,81</b>	0,53	0,40	0,26	0,22	17000	1539		
<b>1550</b>	362,17	4,0		1,4	<b>0,71</b>	0,46	0,35	0,26	0,20	17000	1549		
<b>1550</b>	383,35	3,8		1,3	<b>0,67</b>	0,44	0,33	0,24	0,18	17000	1564		
<b>1550</b>	458,98	3,2		1,1	<b>0,56</b>	0,37	0,28	0,20	0,15	17000	1606		
<b>1550</b>	522,66	2,8		0,98	<b>0,49</b>	0,32	0,27	0,18	0,14	17000	1633		
<b>1550</b>	584,15	2,5		0,88	<b>0,44</b>	0,29	0,24	0,16	0,12	17000	1653		
<b>1550</b>	648,55	2,2	<b>DT475</b>	0,81	<b>0,41</b>	0,27	0,23	0,15	0,11	17000	760	116	284
<b>1550</b>	752,10	1,9		0,70	<b>0,35</b>	0,25	0,19	0,13	0,10	17000	767		
<b>1550</b>	900,55	1,6		0,59	<b>0,29</b>	0,21	0,16	0,11	0,08	17000	775		
<b>1550</b>	1065,48	1,4		0,55	<b>0,28</b>	0,20	0,15	0,10	0,08	17000	780		
<b>1550</b>	1140,69	1,3		0,51	<b>0,26</b>	0,19	0,14	0,09	0,07	17000	782		
<b>1550</b>	1492,69	1,0		0,39	<b>0,20</b>	0,14	0,11	0,07	0,05	17000	796		
<b>1550</b>	1529,03	0,95		0,38	<b>0,19</b>	0,14	0,11	0,07	0,05	17000	798		
<b>1550</b>	1618,43	0,90		0,36	<b>0,18</b>	0,13	0,10	0,07	0,05	17000	802		
<b>1550</b>	1937,71	0,75		0,30	<b>0,15</b>	0,11	0,08	0,06	0,04	17000	813		
<b>1550</b>	2381,67	0,61	<b>DT476</b>	0,25	<b>0,13</b>	0,09	0,07	0,05	0,03	17000	837	118	284
<b>1550</b>	2851,73	0,51		0,23	<b>0,11</b>	0,08	0,06	0,04	0,03	17000	840		
<b>1550</b>	3374,03	0,43		0,20	<b>0,09</b>	0,06	0,05	0,03	0,02	17000	841		
<b>1550</b>	3612,19	0,40		0,19	<b>0,08</b>	0,06	0,05	0,03	0,02	17000	842		
<b>1550</b>	4726,85	0,31		0,14	<b>0,06</b>	0,05	0,04	0,02	0,02	17000	846		
<b>1550</b>	4841,94	0,30		0,14	<b>0,06</b>	0,05	0,03	0,02	0,02	17000	847		
<b>1550</b>	5125,04	0,28		0,13	<b>0,06</b>	0,04	0,03	0,02	0,02	17000	848		
<b>1550</b>	6136,10	0,24		0,11	<b>0,05</b>	0,04	0,03	0,02	0,01	17000	852		
<b>1470</b>	4,38	331	<b>DT572</b>	-	<b>52</b>	39	32	24	20	22142	-	150	286
<b>1570</b>	4,96	292		-	<b>49</b>	37	30	23	19	22799	-		
<b>1670</b>	5,64	257		-	<b>46</b>	35	28	21	17	23536	-		
<b>1780</b>	6,45	225		-	<b>43</b>	32	26	20	16	24330	-		
<b>1900</b>	7,43	195		-	<b>40</b>	30	24	18	15	25207	-		
<b>2030</b>	8,65	168		60	<b>37</b>	28	22	17	14	26199	-		
<b>2560</b>	10,45	139		-	<b>38</b>	29	23	15	11	27328	-		
<b>2710</b>	11,89	122		-	<b>36</b>	26	20	13	9,9	28223	-		
<b>2870</b>	13,60	107		-	<b>33</b>	23	17	11	8,7	25802	-		
<b>3000</b>	15,67	93		-	<b>30</b>	20	15	9,9	7,5	22500	-		
<b>3000</b>	18,23	80		45	<b>26</b>	17	13	8,5	6,5	22500	-		
<b>3000</b>	21,40	68		41	<b>22</b>	14	11	7,3	5,5	22500	-		
<b>3000</b>	24,02	60		38	<b>20</b>	13	10	6,5	4,9	22500	-		
<b>3000</b>	28,87	50		33	<b>16</b>	11	8,2	5,4	4,1	22500	-		
<b>3000</b>	33,86	43		28	<b>14</b>	9,2	7,0	4,6	3,5	22500	-		
<b>2600</b>	28,39	51	<b>DT573</b>	-	<b>14</b>	10	8,3	5,5	4,1	31019	-	153	286
<b>2750</b>	33,28	44		-	<b>13</b>	9,3	7,1	4,7	3,5	28304	-		
<b>2910</b>	39,35	37		18	<b>12</b>	7,9	6,0	4,0	3,0	24887	-		
<b>3000</b>	44,27	33		17	<b>11</b>	7,0	5,4	3,5	2,7	22500	-		
<b>3000</b>	50,13	29		16	<b>9,4</b>	6,2	4,7	3,1	2,4	22500	-		
<b>3000</b>	61,12	24		14	<b>7,7</b>	5,1	3,9	2,6	1,9	22500	-		
<b>3000</b>	68,64	21		-	<b>6,9</b>	4,5	3,4	2,3	1,7	22500	1566		

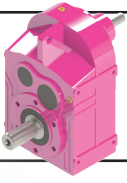

# D Serisi Motorsuz Güç Devir Sayfaları

## D Series Gear Units Performance Tables

### D Serien Getriebe Leistung und Drehzahlübersicht



Anma Momenti <i>Nominal Torques</i> Nenn-drehmomente Ma [Nm] (n1=1450rpm)	Çevrim Oranı <i>Ratio</i> Übersetzung i	Çıkış Devri <i>Output Speeds</i> Abtriebs-drehzahlen n2 [r.p.m] (n1=1450rpm)	Tipi <i>Type</i> Typ	Pe= Nominal Güç [kW] (Servis Faktörü fs=1,0 için) <i>Pe= Nominal Power [kW] (For Service Factor fs=1,0)</i> Pe= NennLeistung [kW] (Bei Betriebsfaktor fs=1,0)						Güv. Rad.Yük Çıkış <i>Per.O.Loads (Output)</i> Zul.Querkräfte (Abtrieb) Fqam [N] (n1=1450rpm)	Güv.Rad.Yük Giriş <i>Per.O.Loads (Input)</i> Zul.Querkräfte (Antrieb) Fqem [N] (n1=1450rpm)	Ağırlık <i>Weight</i> Gewicht [kg]	Ölçü Sayfası <i>Dim. Page</i> Maße Seite
				Giriş devri[d/d] / Input speed[rpm] / Antriebsdrehzahl[upm]									
				n1=2900	n1=1450	n1=950	n1=725	n1=475	n1=360				
<b>3000</b>	81,15	18	<b>DT573</b>	11	<b>5,8</b>	3,8	2,9	1,9	1,5	22500	1630	153	286
<b>3000</b>	91,30	16		10	<b>5,2</b>	3,4	2,6	1,7	1,3	22500	1669		
<b>3000</b>	103,39	14		9,1	<b>4,6</b>	3,0	2,3	1,5	1,1	22500	1705		
<b>3000</b>	126,06	12		7,5	<b>3,8</b>	2,5	1,9	1,2	0,94	22500	1752		
<b>3000</b>	149,15	9,7		6,4	<b>3,2</b>	2,1	1,6	1,1	0,80	22500	1786		
<b>3000</b>	168,60	8,6		5,6	<b>2,8</b>	1,9	1,4	0,93	0,71	22500	1807		
<b>3000</b>	192,62	7,5		5,0	<b>2,5</b>	1,6	1,2	0,82	0,62	22500	1827		
<b>3000</b>	209,81	6,9		4,5	<b>2,3</b>	1,5	1,1	0,75	0,57	22500	1840		
<b>3000</b>	255,83	5,7		3,7	<b>1,9</b>	1,2	0,95	0,62	0,47	22500	1862		
<b>3000</b>	230,64	6,3	<b>DT574</b>	4,3	<b>2,1</b>	1,4	1,0	0,70	0,53	22500	1796	163	288
<b>3000</b>	274,21	5,3		3,6	<b>1,8</b>	1,2	0,90	0,59	0,45	22500	1821		
<b>3000</b>	310,17	4,7		3,2	<b>1,6</b>	1,0	0,80	0,52	0,40	22500	1836		
<b>3000</b>	353,70	4,1		2,8	<b>1,4</b>	0,92	0,70	0,46	0,35	22500	1851		
<b>3000</b>	413,56	3,5		2,4	<b>1,2</b>	0,79	0,60	0,39	0,30	22500	1865		
<b>3000</b>	499,72	2,9		2,0	<b>1,0</b>	0,65	0,50	0,33	0,27	22500	1881		
<b>3000</b>	609,29	2,4		1,6	<b>0,82</b>	0,53	0,41	0,27	0,23	22500	1944		
<b>3000</b>	720,91	2,0		1,4	<b>0,69</b>	0,45	0,35	0,25	0,19	22500	1989		
<b>3000</b>	868,61	1,7	<b>DT575</b>	1,2	<b>0,59</b>	0,38	0,29	0,21	0,16	22500	1707	165	290
<b>3000</b>	1041,50	1,4		0,98	<b>0,49</b>	0,32	0,27	0,18	0,13	22500	1716		
<b>3000</b>	1259,48	1,2		0,81	<b>0,41</b>	0,27	0,23	0,15	0,11	22500	1724		
<b>3000</b>	1439,41	1,0		0,71	<b>0,36</b>	0,26	0,20	0,13	0,10	22500	1728		
<b>3000</b>	1657,21	0,87		0,62	<b>0,31</b>	0,23	0,17	0,11	0,09	22500	1733		
<b>3000</b>	1949,20	0,74		0,53	<b>0,26</b>	0,19	0,15	0,10	0,07	22500	1737		
<b>3000</b>	2078,15	0,70		0,55	<b>0,27</b>	0,20	0,15	0,10	0,08	22500	1738		
<b>3000</b>	2379,02	0,61		0,48	<b>0,24</b>	0,17	0,13	0,09	0,07	22500	1741		
<b>3000</b>	2900,65	0,50		0,39	<b>0,20</b>	0,14	0,11	0,07	0,05	22500	1756		
<b>3000</b>	3432,03	0,42		0,33	<b>0,17</b>	0,12	0,09	0,06	0,05	22500	1766		
<b>3000</b>	3723,69	0,39	<b>DT576</b>	0,31	<b>0,16</b>	0,11	0,09	0,06	0,04	22500	1788	167	290
<b>3000</b>	4255,64	0,34		0,27	<b>0,14</b>	0,10	0,08	0,05	0,04	22500	1790		
<b>3000</b>	4899,59	0,30		0,26	<b>0,12</b>	0,09	0,07	0,04	0,03	22500	1791		
<b>3000</b>	5762,85	0,25		0,22	<b>0,10</b>	0,07	0,06	0,04	0,03	22500	1793		
<b>3000</b>	6144,09	0,24		0,21	<b>0,09</b>	0,07	0,05	0,03	0,03	22500	1793		
<b>3000</b>	7033,63	0,21		0,18	<b>0,08</b>	0,06	0,05	0,03	0,02	22500	1794		
<b>3000</b>	8575,84	0,17		0,15	<b>0,07</b>	0,05	0,04	0,02	0,02	22500	1799		
<b>3000</b>	10146,88	0,14		0,13	<b>0,06</b>	0,04	0,03	0,02	0,02	22500	1803		
<b>2200</b>	4,28	339	<b>DT672</b>	-	<b>80</b>	60	48	37	30	31593	-	201	292
<b>2370</b>	4,92	295		-	<b>75</b>	56	45	35	28	32632	-		
<b>2550</b>	5,68	255		-	<b>70</b>	52	42	32	26	33765	-		
<b>2580</b>	5,89	246		-	<b>68</b>	51	41	31	26	34127	-		
<b>2730</b>	6,61	219		-	<b>64</b>	48	39	30	24	35083	-		
<b>2880</b>	7,45	195		-	<b>60</b>	45	37	28	23	36165	-		
<b>3300</b>	7,75	187		-	<b>66</b>	50	40	29	22	36215	-		
<b>3540</b>	8,91	163		-	<b>62</b>	46	38	25	19	37392	-		
<b>3790</b>	10,29	141		-	<b>58</b>	43	33	22	16	38694	-		
<b>3830</b>	10,67	136		-	<b>56</b>	41	32	21	16	38291	-		
<b>4030</b>	11,96	121		-	<b>53</b>	37	28	19	14	35135	-		
<b>4250</b>	13,48	108		-	<b>49</b>	33	25	16	13	31078	-		
<b>4300</b>	15,30	95		-	<b>44</b>	29	22	15	11	29600	-		
<b>4300</b>	17,49	83		-	<b>39</b>	25	19	13	9,7	29600	-		
<b>4300</b>	20,20	72		63	<b>33</b>	22	17	11	8,4	29600	-		
<b>4300</b>	23,36	62		57	<b>29</b>	19	15	9,5	7,2	29600	-		
<b>4300</b>	26,11	56		52	<b>26</b>	17	13	8,5	6,5	29600	-		
<b>4300</b>	30,04	48	<b>DT673</b>	-	<b>22</b>	15	11	7,4	5,6	29600	370	204	292
<b>4300</b>	34,02	43		-	<b>20</b>	13	10	6,5	5,0	29600	849		
<b>4300</b>	38,70	37		-	<b>17</b>	11	8,7	5,7	4,4	29600	1284		
<b>4300</b>	44,27	33		-	<b>15</b>	10	7,7	5,0	3,8	29600	1681		

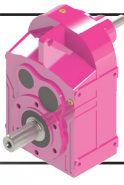

# D Serisi Motorsuz Güç Devir Sayfaları

## D Series Gear Units Performance Tables

### D Serien Getriebe Leistung und Drehzahlübersicht

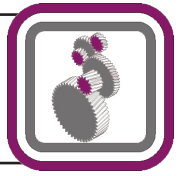

Anma Momenti Nominal Torques Nenn-drehmomente Ma [Nm] (n1=1450rpm)	Çevrim Oranı Ratio Übersetzung i	Çıkış Devri Output Speeds Abtriebs-drehzahlen n2 [r.p.m] (n1=1450rpm)	Tipi Type Typ	Pe= Nominal Güç [kW] (Servis Faktörü fs=1,0 için) Pe= Nominal Power [kW] (For Service Factor fs=1,0) Pe= NennLeistung [kW] (Bei Betriebsfaktor fs=1,0)						Güv. Rad.Yük Çıkış Per.O.Loads (Output) Zul.Querkräfte (Abtrieb) Fqam [N] (n1=1450rpm)	Güv.Rad.Yük Giriş Per.O.Loads (Input) Zul.Querkräfte (Antrieb) Fqem [N] (n1=1450rpm)	Ağırlık Weight Gewicht [kg]	Ölçü Sayfası Dim. Page Maße Seite
				Giriş devri[d/d] / Input speed[rpm] / Antriebsdrehzahl[upm]									
				n1=2900	n1=1450	n1=950	n1=725	n1=475	n1=360				
<b>4300</b>	51,01	28	<b>DT673</b>	-	<b>13</b>	8,7	6,7	4,4	3,3	29600	2043	204	292
<b>4300</b>	59,34	24		23	<b>11</b>	7,5	5,7	3,8	2,9	29600	2374		
<b>4300</b>	60,82	24		-	<b>11</b>	7,3	5,6	3,7	2,8	29600	3134		
<b>4300</b>	69,18	21		-	<b>9,8</b>	6,4	4,9	3,2	2,4	29600	3197		
<b>4300</b>	79,14	18		-	<b>8,5</b>	5,6	4,3	2,8	2,1	29600	3254		
<b>4300</b>	91,19	16		-	<b>7,4</b>	4,9	3,7	2,5	1,9	29600	3305		
<b>4300</b>	106,08	14		13	<b>6,4</b>	4,2	3,2	2,1	1,6	29600	3353		
<b>4300</b>	124,53	12		11	<b>5,5</b>	3,6	2,7	1,8	1,4	29600	3414		
<b>4300</b>	139,76	10		9,7	<b>4,9</b>	3,2	2,4	1,6	1,2	29600	3440		
<b>4300</b>	167,96	8,6		8,1	<b>4,1</b>	2,7	2,0	1,3	1,0	29600	3473		
<b>4300</b>	197,01	7,4		6,9	<b>3,5</b>	2,3	1,7	1,1	0,87	29600	3499		
<b>4300</b>	221,47	6,5		6,2	<b>3,1</b>	2,0	1,6	1,0	0,77	29600	3515		
<b>4300</b>	236,65	6,1	<b>DT674</b>	6,0	<b>3,0</b>	2,0	1,5	0,98	0,74	29600	1622	214	294
<b>4300</b>	281,35	5,2		5,0	<b>2,5</b>	1,7	1,3	0,83	0,63	29600	1657		
<b>4300</b>	318,25	4,6		4,5	<b>2,2</b>	1,5	1,1	0,73	0,55	29600	1679		
<b>4300</b>	362,91	4,0		3,9	<b>2,0</b>	1,3	1,0	0,64	0,49	29600	1699		
<b>4300</b>	424,33	3,4		3,4	<b>1,7</b>	1,1	0,84	0,55	0,42	29600	1720		
<b>4300</b>	512,73	2,8		2,8	<b>1,4</b>	0,91	0,70	0,46	0,35	29600	1741		
<b>4300</b>	601,90	2,4		2,4	<b>1,2</b>	0,78	0,59	0,39	0,29	29600	1814		
<b>4300</b>	675,51	2,1		2,1	<b>1,1</b>	0,69	0,53	0,35	0,26	29600	1859		
<b>4300</b>	747,10	1,9	<b>DT675</b>	1,9	<b>0,97</b>	0,64	0,49	0,32	0,27	29600	1647	216	296
<b>4300</b>	891,23	1,6		1,6	<b>0,82</b>	0,54	0,41	0,27	0,23	29600	1662		
<b>4300</b>	1068,62	1,4		1,4	<b>0,68</b>	0,45	0,34	0,25	0,19	29600	1674		
<b>4300</b>	1292,28	1,1		1,1	<b>0,57</b>	0,37	0,28	0,21	0,16	29600	1685		
<b>4300</b>	1476,89	0,98		0,99	<b>0,50</b>	0,33	0,28	0,18	0,14	29600	1692		
<b>4300</b>	1700,37	0,85		0,87	<b>0,43</b>	0,28	0,24	0,16	0,12	29600	1698		
<b>4300</b>	1999,96	0,73		0,74	<b>0,37</b>	0,27	0,20	0,13	0,10	29600	1703		
<b>4300</b>	2132,27	0,68		0,69	<b>0,35</b>	0,25	0,19	0,13	0,10	29600	1705		
<b>4300</b>	2440,98	0,59		0,60	<b>0,30</b>	0,22	0,17	0,11	0,08	29600	1709		
<b>4300</b>	2865,49	0,51		0,51	<b>0,26</b>	0,19	0,14	0,09	0,07	29600	1726		
<b>4300</b>	3215,89	0,45		0,51	<b>0,25</b>	0,19	0,14	0,09	0,07	29600	1736		
<b>4300</b>	3820,66	0,38	<b>DT676</b>	0,44	<b>0,22</b>	0,16	0,12	0,08	0,06	29600	1775	218	296
<b>4300</b>	4366,47	0,33		0,38	<b>0,19</b>	0,14	0,11	0,07	0,05	29600	1777		
<b>4300</b>	5027,18	0,29		0,33	<b>0,17</b>	0,12	0,09	0,06	0,05	29600	1780		
<b>4300</b>	5912,93	0,25		0,28	<b>0,14</b>	0,10	0,08	0,05	0,04	29600	1781		
<b>4300</b>	6304,09	0,23		0,27	<b>0,13</b>	0,10	0,07	0,05	0,04	29600	1782		
<b>4300</b>	7216,80	0,20		0,26	<b>0,12</b>	0,08	0,06	0,04	0,03	29600	1783		
<b>4300</b>	8471,90	0,17		0,22	<b>0,10</b>	0,07	0,05	0,04	0,03	29600	1789		
<b>4300</b>	9507,85	0,15		0,20	<b>0,09</b>	0,06	0,05	0,03	0,02	29600	1793		
<b>3800</b>	4,47	325	<b>DT772</b>	-	<b>132</b>	100	80	61	50	30034	-	275	298
<b>4080</b>	5,06	287		-	<b>125</b>	94	76	58	47	30748	-		
<b>4350</b>	5,75	252		-	<b>118</b>	88	71	54	44	31612	-		
<b>4630</b>	6,58	220		-	<b>110</b>	82	66	51	41	32592	-		
<b>4770</b>	6,97	208		-	<b>107</b>	80	64	49	40	32969	-		
<b>5010</b>	7,76	187		-	<b>101</b>	75	61	46	37	33787	-		
<b>5260</b>	8,70	167		-	<b>94</b>	71	57	44	36	34710	-		
<b>6050</b>	9,00	161		-	<b>105</b>	79	63	46	35	34844	-		
<b>6420</b>	10,23	142		-	<b>98</b>	73	59	40	31	35845	-		
<b>6820</b>	11,71	124		-	<b>91</b>	68	54	35	27	36936	-		
<b>7000</b>	12,40	117		-	<b>88</b>	66	51	33	25	37404	-		
<b>7330</b>	13,81	105		-	<b>83</b>	60	46	30	23	38349	-		
<b>7680</b>	15,46	94		-	<b>78</b>	53	41	27	20	39400	-		
<b>8000</b>	17,44	83		-	<b>72</b>	47	36	24	18	40735	-		
<b>8000</b>	19,82	73		-	<b>63</b>	42	32	21	16	43221	-		
<b>8000</b>	22,77	64		100	<b>55</b>	36	28	18	14	46018	-		
<b>5560</b>	17,95	81	<b>DT773</b>	-	<b>48</b>	36	29	22	17	46247	-	276	298

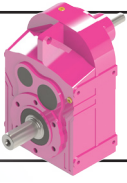

# D Serisi Motorsuz Güç Devir Sayfaları

## D Series Gear Units Performance Tables

### D Serien Getriebe Leistung und Drehzahlübersicht



Anma Momenti <i>Nominal Torques</i> Nenn-drehmomente Ma [Nm] (n1=1450rpm)	Çevrim Oranı <i>Ratio</i> Übersetzung i	Çıkış Devri <i>Output Speeds</i> Abtriebs-drehzahlen n2 [r.p.m] (n1=1450rpm)	Tipi <i>Type</i> Typ	Pe= Nominal Güç [kW] (Servis Faktörü fs=1,0 için) <i>Pe= Nominal Power [kW] (For Service Factor fs=1,0)</i> Pe= NennLeistung [kW] (Bei Betriebsfaktor fs=1,0)						Güv. Rad.Yük Çıkış <i>Per.O.Loads (Output)</i>	Güv.Rad.Yük Giriş <i>Per.O.Loads (Input)</i>	Ağırlık <i>Weight</i> Gewicht [kg]	Ölçü Sayfası <i>Dim. Page</i> Maße Seite
				Giriş devri[d/d] / Input speed[rpm] / Antriebsdrehzahl[upm]									
				n1=2900	n1=1450	n1=950	n1=725	n1=475	n1=360				
<b>5620</b>	18,61	78	<b>DT773</b>	-	<b>47</b>	35	28	22	17	46758	-	276	298
<b>5820</b>	20,87	69		-	<b>43</b>	33	26	20	15	48384	-		
<b>8000</b>	24,06	60		-	<b>52</b>	34	26	17	13	47165	-		
<b>8000</b>	27,65	52		-	<b>45</b>	30	23	15	11	50137	-		
<b>8000</b>	31,92	45		-	<b>39</b>	26	20	13	9,8	53342	-		
<b>8000</b>	33,10	44		-	<b>38</b>	25	19	12	9,5	54175	-		
<b>8000</b>	37,12	39		-	<b>34</b>	22	17	11	8,4	55500	-		
<b>8000</b>	41,85	35		-	<b>30</b>	20	15	9,9	7,5	55500	-		
<b>8000</b>	46,99	31		-	<b>27</b>	17	13	8,8	6,7	55500	2038		
<b>8000</b>	53,99	27		-	<b>23</b>	15	12	7,6	5,8	55500	2582		
<b>8000</b>	62,33	23		-	<b>20</b>	13	10	6,6	5,0	55500	3029		
<b>8000</b>	64,64	22		-	<b>19</b>	13	10	6,4	4,8	55500	3039		
<b>8000</b>	72,50	20		-	<b>17</b>	11	8,7	5,7	4,3	55500	3122		
<b>8000</b>	81,72	18		-	<b>15</b>	10	7,7	5,1	3,8	55500	3199		
<b>8000</b>	92,70	16		-	<b>14</b>	8,9	6,8	4,5	3,4	55500	3270		
<b>8000</b>	105,99	14		-	<b>12</b>	7,8	6,0	3,9	3,0	55500	3335		
<b>8000</b>	122,41	12		21	<b>10</b>	6,8	5,2	3,4	2,6	55500	3396		
<b>8000</b>	141,55	10		18	<b>8,9</b>	5,9	4,5	2,9	2,2	55500	3469		
<b>8000</b>	158,23	9,2		16	<b>8,0</b>	5,2	4,0	2,6	2,0	55500	3504		
<b>8000</b>	190,20	7,6		13	<b>6,6</b>	4,4	3,3	2,2	1,7	55500	3555		
<b>8000</b>	222,16	6,5		11	<b>5,7</b>	3,7	2,9	1,9	1,4	55500	3590		
<b>8000</b>	223,53	6,5	<b>DT774</b>	12	<b>5,9</b>	3,9	2,9	1,9	1,5	55500	1646	288	300
<b>8000</b>	256,48	5,7		10	<b>5,1</b>	3,4	2,6	1,7	1,3	55500	1697		
<b>8000</b>	296,36	4,9		8,9	<b>4,5</b>	2,9	2,2	1,5	1,1	55500	1743		
<b>8000</b>	321,33	4,5		8,2	<b>4,1</b>	2,7	2,1	1,3	1,0	55500	1769		
<b>8000</b>	384,72	3,8		6,9	<b>3,4</b>	2,3	1,7	1,1	0,85	55500	1814		
<b>8000</b>	438,10	3,3		6,0	<b>3,0</b>	2,0	1,5	0,99	0,75	55500	1842		
<b>8000</b>	489,64	3,0		5,4	<b>2,7</b>	1,8	1,4	0,89	0,67	55500	1867		
<b>8000</b>	566,21	2,6		4,7	<b>2,3</b>	1,5	1,2	0,77	0,58	55500	1966		
<b>8000</b>	632,92	2,3		4,2	<b>2,1</b>	1,4	1,0	0,69	0,52	55500	2033		
<b>8000</b>	730,48	2,0	<b>DT775</b>	3,7	<b>1,9</b>	1,2	0,93	0,61	0,46	55500	1898	291	302
<b>8000</b>	874,59	1,7		3,1	<b>1,6</b>	1,0	0,78	0,51	0,39	55500	1916		
<b>8000</b>	995,95	1,5		2,7	<b>1,4</b>	0,90	0,68	0,45	0,34	55500	1928		
<b>8000</b>	1105,59	1,3		2,5	<b>1,2</b>	0,80	0,61	0,40	0,30	55500	2011		
<b>8000</b>	1323,71	1,1		2,1	<b>1,0</b>	0,67	0,51	0,34	0,26	55500	2024		
<b>8000</b>	1507,38	0,96		1,8	<b>0,90</b>	0,59	0,45	0,30	0,25	55500	2031		
<b>8000</b>	1656,07	0,88		1,6	<b>0,82</b>	0,54	0,41	0,27	0,23	55500	2085		
<b>8000</b>	1982,78	0,73		1,4	<b>0,69</b>	0,45	0,34	0,25	0,19	55500	2093		
<b>8000</b>	2257,90	0,64		1,2	<b>0,61</b>	0,40	0,30	0,22	0,17	55500	2098		
<b>8000</b>	2523,53	0,57		1,1	<b>0,54</b>	0,35	0,27	0,20	0,15	55500	2103		
<b>8000</b>	2855,58	0,51		0,96	<b>0,48</b>	0,31	0,27	0,17	0,13	55500	2106		
<b>8000</b>	3302,14	0,44		0,83	<b>0,41</b>	0,27	0,23	0,15	0,11	55500	2123		
<b>8000</b>	3691,20	0,39		0,74	<b>0,37</b>	0,27	0,21	0,13	0,10	55500	2135		
<b>8000</b>	3922,75	0,37	<b>DT776</b>	0,71	<b>0,36</b>	0,26	0,20	0,13	0,10	55500	2179	293	302
<b>8000</b>	4334,63	0,33		0,64	<b>0,32</b>	0,23	0,18	0,12	0,09	55500	2181		
<b>8000</b>	5058,99	0,29		0,55	<b>0,28</b>	0,20	0,15	0,10	0,08	55500	2184		
<b>8000</b>	5875,88	0,25		0,53	<b>0,26</b>	0,19	0,15	0,10	0,07	55500	2197		
<b>8000</b>	6492,84	0,22		0,48	<b>0,24</b>	0,17	0,13	0,09	0,07	55500	2198		
<b>8000</b>	7577,86	0,19		0,41	<b>0,21</b>	0,15	0,11	0,07	0,06	55500	2200		
<b>8000</b>	8913,25	0,16		0,35	<b>0,17</b>	0,13	0,10	0,06	0,05	55500	2202		
<b>8000</b>	10597,02	0,14		0,29	<b>0,15</b>	0,11	0,08	0,05	0,04	55500	2204		
<b>8000</b>	11986,79	0,12		0,26	<b>0,13</b>	0,10	0,07	0,05	0,04	55500	2205		
<b>8000</b>	13669,15	0,11		0,25	<b>0,11</b>	0,08	0,06	0,04	0,03	55500	2206		
<b>8000</b>	16981,28	0,09		0,21	<b>0,09</b>	0,07	0,05	0,03	0,03	55500	2207		
<b>8000</b>	19312,05	0,08		0,18	<b>0,08</b>	0,06	0,05	0,03	0,02	55500	2208		
<b>8000</b>	22332,10	0,06		0,16	<b>0,07</b>	0,05	0,04	0,03	0,02	55500	2211		
<b>8000</b>	24963,27	0,06		0,14	<b>0,06</b>	0,05	0,03	0,02	0,02	55500	2214		
<b>6660</b>	5,66	256	<b>DT872</b>	-	<b>183</b>	137	110	84	69	24062	-	390	304

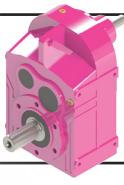

# D Serisi Motorsuz Güç Devir Sayfaları

## D Series Gear Units Performance Tables

### D Serien Getriebe Leistung und Drehzahlübersicht



Anma Momenti <i>Nominal Torques</i> Nenn-drehmomente Ma [Nm] (n1=1450rpm)	Çevrim Oranı	Çıkış Devri	Tipi	Pe= Nominal Güç [kW] (Servis Faktörü fs=1,0 için)						Güv. Rad.Yük Çıkış	Güv.Rad.Yük Giriş	Ağırlık	Ölçü Sayfası
	Ratio	Output Speeds		Type	Pe= Nominal Power [kW] (For Service Factor fs=1,0)						Per.O.Loads (Output)		
	Übersetzung	Abtriebs-drehzahlen	Typ	Giriş devri[d/d] / Input speed[rpm] / Antriebsdrehzahl[upm]						Zul.Querkräfte (Abtrieb)	Zul.Querkräfte (Antrieb)	Gewicht	Maße Seite
	i	n2 [r.p.m] (n1=1450rpm)		n1=2900	n1=1450	n1=950	n1=725	n1=475	n1=360	Fqam [N] (n1=1450rpm)	Fqem [N] (n1=1450rpm)	[kg]	
<b>7040</b>	6,35	228	<b>DT872</b>	-	<b>172</b>	129	104	80	65	28406	-	390	304
<b>7440</b>	7,16	202		-	<b>162</b>	121	98	75	61	33157	-		
<b>7870</b>	8,12	179		-	<b>151</b>	113	91	70	57	38380	-		
<b>9130</b>	8,75	166		-	<b>162</b>	122	98	75	58	41694	-		
<b>9610</b>	9,78	148		-	<b>153</b>	115	93	68	52	46426	-		
<b>10120</b>	10,97	132		-	<b>144</b>	108	87	61	46	51518	-		
<b>10660</b>	12,36	117		-	<b>135</b>	101	81	54	41	57074	-		
<b>11250</b>	14,02	103		-	<b>125</b>	94	73	48	36	63142	-		
<b>10150</b>	13,58	107	<b>DT873</b>	-	<b>116</b>	87	70	49	37	60141	-	394	304
<b>10550</b>	15,45	94		-	<b>106</b>	80	64	43	33	66375	-		
<b>11000</b>	17,67	82		-	<b>97</b>	73	58	38	29	69064	-		
<b>13000</b>	23,44	62		-	<b>86</b>	57	43	29	22	76000	-		
<b>13000</b>	26,66	54		-	<b>76</b>	50	38	25	19	76000	-		
<b>13000</b>	30,50	48		-	<b>67</b>	44	33	22	17	76000	-		
<b>13000</b>	35,24	41		-	<b>57</b>	38	29	19	14	76000	-		
<b>13000</b>	39,92	36		-	<b>51</b>	33	26	17	13	76000	1134		
<b>13000</b>	45,41	32		-	<b>45</b>	29	22	15	11	76000	1938		
<b>13000</b>	51,94	28		-	<b>39</b>	26	20	13	9,8	76000	2678		
<b>13000</b>	55,01	26		-	<b>37</b>	24	19	12	9,3	76000	3038		
<b>13000</b>	61,27	24		-	<b>33</b>	22	17	11	8,3	76000	3530		
<b>13000</b>	68,62	21		-	<b>30</b>	19	15	9,8	7,4	76000	3992		
<b>13000</b>	77,36	19		-	<b>26</b>	17	13	8,7	6,6	76000	4424		
<b>13000</b>	87,95	16		-	<b>23</b>	15	12	7,7	5,8	76000	4829		
<b>13000</b>	101,03	14		40	<b>20</b>	13	10	6,7	5,1	76000	5085		
<b>13000</b>	115,03	13		35	<b>18</b>	12	8,9	5,9	4,5	76000	5167		
<b>13000</b>	128,20	11		32	<b>16</b>	10	8,0	5,3	4,0	76000	5218		
<b>13000</b>	139,70	10	<b>DT874</b>	30	<b>15</b>	9,9	7,6	5,0	3,8	76000	167	404	306
<b>13000</b>	156,45	9,3		27	<b>14</b>	8,9	6,8	4,4	3,4	76000	1166		
<b>13000</b>	176,39	8,2		24	<b>12</b>	7,9	6,0	3,9	3,0	76000	2108		
<b>13000</b>	200,52	7,2		21	<b>11</b>	7,0	5,3	3,5	2,6	76000	2670		
<b>13000</b>	225,61	6,4		19	<b>9,5</b>	6,2	4,7	3,1	2,3	76000	2730		
<b>13000</b>	259,15	5,6		16	<b>8,2</b>	5,4	4,1	2,7	2,0	76000	2911		
<b>13000</b>	293,46	4,9		15	<b>7,3</b>	4,8	3,6	2,4	1,8	76000	2960		
<b>13000</b>	334,15	4,3		13	<b>6,4</b>	4,2	3,2	2,1	1,6	76000	3102		
<b>13000</b>	407,42	3,6		11	<b>5,3</b>	3,4	2,6	1,7	1,3	76000	3157		
<b>13000</b>	482,05	3,0		8,9	<b>4,4</b>	2,9	2,2	1,5	1,1	76000	3198		
<b>13000</b>	537,22	2,7		8,0	<b>4,0</b>	2,6	2,0	1,3	0,99	76000	3293		
<b>13000</b>	607,27	2,4		7,1	<b>3,5</b>	2,3	1,8	1,2	0,88	76000	3316		
<b>13000</b>	686,44	2,1	<b>DT875</b>	6,4	<b>3,2</b>	2,1	1,6	1,0	0,80	76000	1682	407	308
<b>13000</b>	744,27	1,9		5,9	<b>3,0</b>	1,9	1,5	0,97	0,73	76000	1699		
<b>13000</b>	828,93	1,7		5,3	<b>2,7</b>	1,7	1,3	0,87	0,66	76000	1753		
<b>13000</b>	928,31	1,6		4,7	<b>2,4</b>	1,6	1,2	0,78	0,59	76000	1804		
<b>13000</b>	1046,63	1,4		4,2	<b>2,1</b>	1,4	1,1	0,69	0,52	76000	1853		
<b>13000</b>	1189,85	1,2		3,7	<b>1,9</b>	1,2	0,93	0,61	0,46	76000	1899		
<b>13000</b>	1424,58	1,0		3,1	<b>1,6</b>	1,0	0,78	0,51	0,39	76000	1917		
<b>13000</b>	1622,25	0,89		2,7	<b>1,4</b>	0,89	0,68	0,45	0,34	76000	1928		
<b>13000</b>	1813,10	0,80		2,4	<b>1,2</b>	0,80	0,61	0,40	0,30	76000	1939		
<b>13000</b>	2051,67	0,71		2,2	<b>1,1</b>	0,71	0,54	0,35	0,27	76000	1947		
<b>13000</b>	2356,74	0,62		1,9	<b>0,94</b>	0,62	0,47	0,31	0,26	76000	1984		
<b>13000</b>	2683,53	0,54		1,7	<b>0,83</b>	0,54	0,41	0,27	0,23	76000	2014		
<b>13000</b>	2990,66	0,48		1,5	<b>0,74</b>	0,49	0,37	0,27	0,20	76000	2037		
<b>13000</b>	3405,63	0,43	<b>DT876</b>	1,3	<b>0,67</b>	0,44	0,33	0,24	0,18	76000	2117	409	308
<b>13000</b>	4005,78	0,36		1,1	<b>0,57</b>	0,37	0,28	0,21	0,16	76000	2123		
<b>13000</b>	4762,49	0,30		0,96	<b>0,48</b>	0,31	0,27	0,17	0,13	76000	2130		
<b>13000</b>	5304,23	0,27		0,86	<b>0,43</b>	0,28	0,24	0,16	0,12	76000	2140		
<b>13000</b>	5940,18	0,24		0,77	<b>0,38</b>	0,25	0,21	0,14	0,11	76000	2150		
<b>13000</b>	6697,26	0,22		0,68	<b>0,34</b>	0,25	0,19	0,12	0,09	76000	2159		
<b>13000</b>	7613,73	0,19		0,60	<b>0,30</b>	0,22	0,17	0,11	0,08	76000	2168		

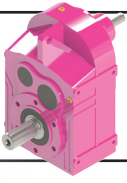

# D Serisi Motorsuz Güç Devir Sayfaları

## D Series Gear Units Performance Tables

### D Serien Getriebe Leistung und Drehzahlübersicht



Anma Momenti <i>Nominal Torques</i> Nenn-drehmomente Ma [Nm] (n1=1450rpm)	Çevrim Oranı	Çıkış Devri	Tipi	Pe= Nominal Güç [kW] (Servis Faktörü fs=1,0 için)						Güv. Rad.Yük Çıkış	Güv.Rad.Yük Giriş	Ağırlık	Ölçü Sayfası
	Ratio	Output Speeds		Type	Pe= Nominal Power [kW] (For Service Factor fs=1,0)								
	Übersetzung	Abtriebs-drehzahlen	Typ	Giriş devri[d/d] / Input speed[rpm] / Antriebsdrehzahl[upm]						Zul.Querkräfte (Abtrieb)	Zul.Querkräfte (Antrieb)	Weight	Dim. Page
	i	n2 [r.p.m] (n1=1450rpm)		n1=2900	n1=1450	n1=950	n1=725	n1=475	n1=360	Fqam [N] (n1=1450rpm)	Fqem [N] (n1=1450rpm)	[kg]	Maße Seite
<b>13000</b>	8612,25	0,17	<b>DT876</b>	0,53	<b>0,27</b>	0,19	0,15	0,10	0,07	76000	2171	409	308
<b>13000</b>	9820,98	0,15		0,52	<b>0,26</b>	0,19	0,14	0,09	0,07	76000	2173		
<b>13000</b>	12200,68	0,12		0,42	<b>0,21</b>	0,15	0,12	0,08	0,06	76000	2176		
<b>13000</b>	13875,29	0,10		0,37	<b>0,18</b>	0,13	0,10	0,07	0,05	76000	2178		
<b>13000</b>	15938,44	0,09		0,32	<b>0,16</b>	0,12	0,09	0,06	0,04	76000	2185		
<b>13000</b>	18148,47	0,08		0,28	<b>0,14</b>	0,10	0,08	0,05	0,04	76000	2190		
<b>13000</b>	20225,62	0,07		0,25	<b>0,13</b>	0,09	0,07	0,05	0,03	76000	2195		
<b>12860</b>	7,08	205	<b>DT972</b>	-	<b>282</b>	211	171	130	99	56290	-	570	310
<b>13490</b>	7,88	184		-	<b>266</b>	199	161	117	89	57625	-		
<b>14170</b>	8,82	164		-	<b>250</b>	187	151	105	80	59086	-		
<b>14900</b>	9,94	146		-	<b>233</b>	175	141	93	71	60730	-		
<b>17920</b>	11,85	122		-	<b>236</b>	156	119	78	59	63010	-		
<b>18000</b>	13,19	110		-	<b>213</b>	140	107	70	53	66171	-		
<b>18000</b>	14,77	98		-	<b>190</b>	125	96	63	48	69795	-		
<b>18000</b>	16,64	87		-	<b>169</b>	111	85	56	42	73773	-		
<b>16800</b>	20,27	72	<b>DT973</b>	-	<b>129</b>	91	69	46	35	79179	19858	575	310
<b>17400</b>	22,85	63		-	<b>118</b>	81	62	40	31	82111	19950		
<b>18000</b>	25,92	56		-	<b>108</b>	71	54	36	27	85446	20039		
<b>18000</b>	33,93	43		-	<b>83</b>	54	42	27	21	100000	22918		
<b>18000</b>	38,24	38		-	<b>73</b>	48	37	24	18	100000	23163		
<b>18000</b>	43,38	33		-	<b>65</b>	43	33	21	16	100000	23390		
<b>18000</b>	50,12	29		-	<b>56</b>	37	28	18	14	100000	24913		
<b>18000</b>	56,21	26		-	<b>50</b>	33	25	16	13	100000	25074		
<b>18000</b>	63,36	23		-	<b>44</b>	29	22	15	11	100000	25222		
<b>18000</b>	71,87	20		-	<b>39</b>	26	20	13	9,8	100000	25359		
<b>18000</b>	84,31	17		-	<b>33</b>	22	17	11	8,4	100000	25531		
<b>18000</b>	93,91	15		-	<b>30</b>	20	15	9,9	7,5	100000	25619		
<b>18000</b>	105,33	14		-	<b>27</b>	18	13	8,8	6,7	100000	25702		
<b>18000</b>	119,15	12		-	<b>24</b>	16	12	7,8	5,9	100000	25781		
<b>18000</b>	136,23	11		41	<b>21</b>	14	10	6,9	5,2	100000	25856		
<b>18000</b>	153,87	9,4		37	<b>18</b>	12	9,2	6,1	4,6	100000	25922		
<b>18000</b>	171,00	8,5		33	<b>17</b>	11	8,3	5,5	4,2	100000	25968		
<b>18000</b>	191,74	7,6		29	<b>15</b>	9,7	7,4	4,9	3,7	100000	26012		
<b>18000</b>	197,95	7,3	<b>DT974</b>	30	<b>15</b>	9,7	7,4	4,9	3,7	100000	1505	587	312
<b>18000</b>	222,15	6,5		27	<b>13</b>	8,7	6,6	4,3	3,3	100000	1770		
<b>18000</b>	250,41	5,8		24	<b>12</b>	7,7	5,9	3,9	2,9	100000	2850		
<b>18000</b>	284,06	5,1		21	<b>10</b>	6,8	5,2	3,4	2,6	100000	3264		
<b>18000</b>	333,23	4,4		18	<b>8,9</b>	5,8	4,4	2,9	2,2	100000	3501		
<b>18000</b>	371,15	3,9		16	<b>8,0</b>	5,2	4,0	2,6	2,0	100000	3640		
<b>18000</b>	415,16	3,5		14	<b>7,1</b>	4,7	3,6	2,3	1,8	100000	3663		
<b>18000</b>	523,19	2,8		11	<b>5,7</b>	3,7	2,8	1,9	1,4	100000	3727		
<b>18000</b>	474,03	3,1	<b>DT975</b>	13	<b>6,4</b>	4,2	3,2	2,1	1,6	100000	1415	592	314
<b>18000</b>	560,97	2,6		11	<b>5,4</b>	3,5	2,7	1,8	1,3	100000	1471		
<b>18000</b>	603,97	2,4		10	<b>5,0</b>	3,3	2,5	1,6	1,2	100000	1514		
<b>18000</b>	679,53	2,1		8,9	<b>4,5</b>	2,9	2,2	1,5	1,1	100000	1545		
<b>18000</b>	769,47	1,9		7,9	<b>3,9</b>	2,6	2,0	1,3	0,98	100000	1573		
<b>18000</b>	864,41	1,7		7,0	<b>3,5</b>	2,3	1,8	1,2	0,87	100000	1590		
<b>18000</b>	938,19	1,5		6,5	<b>3,2</b>	2,1	1,6	1,1	0,81	100000	1610		
<b>18000</b>	1110,06	1,3		5,5	<b>2,7</b>	1,8	1,4	0,90	0,68	100000	1638		
<b>18000</b>	1244,98	1,2		4,9	<b>2,5</b>	1,6	1,2	0,80	0,61	100000	1704		
<b>18000</b>	1403,36	1,0		4,4	<b>2,2</b>	1,4	1,1	0,71	0,54	100000	1766		
<b>18000</b>	1591,90	0,91		3,8	<b>1,9</b>	1,3	0,96	0,63	0,48	100000	1823		
<b>18000</b>	1867,46	0,78		3,3	<b>1,6</b>	1,1	0,82	0,54	0,41	100000	1887		
<b>18000</b>	2079,97	0,70		2,9	<b>1,5</b>	0,96	0,73	0,48	0,36	100000	1924		
<b>18000</b>	2909,37	0,50	<b>DT976</b>	2,1	<b>1,1</b>	0,70	0,54	0,35	0,27	100000	2052	595	314
<b>18000</b>	3079,47	0,47		2,0	<b>1,0</b>	0,66	0,51	0,33	0,25	100000	2056		

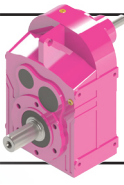

# D Serisi Motorsuz Güç Devir Sayfaları

## D Series Gear Units Performance Tables

### D Serien Getriebe Leistung und Drehzahlübersicht



Anma Momenti Nominal Torques Nenn-drehmomente Ma [Nm] (n1=1450rpm)	Çevrim Oranı Ratio Übersetzung i	Çıkış Devri Output Speeds Abtriebs-drehzahlen n2 [r.p.m] (n1=1450rpm)	Tipi Type Typ	Pe= Nominal Güç [kW] (Servis Faktörü fs=1,0 için) Pe= Nominal Power [kW] (For Service Factor fs=1,0) Pe= NennLeistung [kW] (Bei Betriebsfaktor fs=1,0)						Güv. Rad.Yük Çıkış Per.O.Loads (Output) Zul.Querkräfte (Abtrieb) Fqam [N] (n1=1450rpm)	Güv.Rad.Yük Giriş Per.O.Loads (Input) Zul.Querkräfte (Antrieb) Fqem [N] (n1=1450rpm)	Ağırlık Weight Gewicht [kg]	Ölçü Sayfası Dim. Page Maße Seite
				Giriş devri[d/d] / Input speed[rpm] / Antriebsdrehzahl[upm]									
				n1=2900	n1=1450	n1=950	n1=725	n1=475	n1=360				
18000	3686,99	0,39	DT976	1,7	0,85	0,56	0,42	0,28	0,23	100000	2066	595	314
18000	4589,41	0,32		1,4	0,68	0,45	0,34	0,25	0,19	100000	2120		
18000	5494,80	0,26		1,1	0,57	0,37	0,29	0,21	0,16	100000	2127		
18000	7017,74	0,21		0,90	0,45	0,29	0,25	0,16	0,12	100000	2144		
18000	8841,14	0,16		0,71	0,36	0,26	0,20	0,13	0,10	100000	2159		
18000	11348,58	0,13		0,56	0,28	0,20	0,15	0,10	0,08	100000	2173		
18000	16360,74	0,09		0,43	0,21	0,16	0,12	0,08	0,06	100000	2187		
18000	20565,73	0,07		0,34	0,17	0,12	0,09	0,06	0,05	100000	2195		

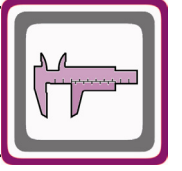

# Ölçü Tabloları

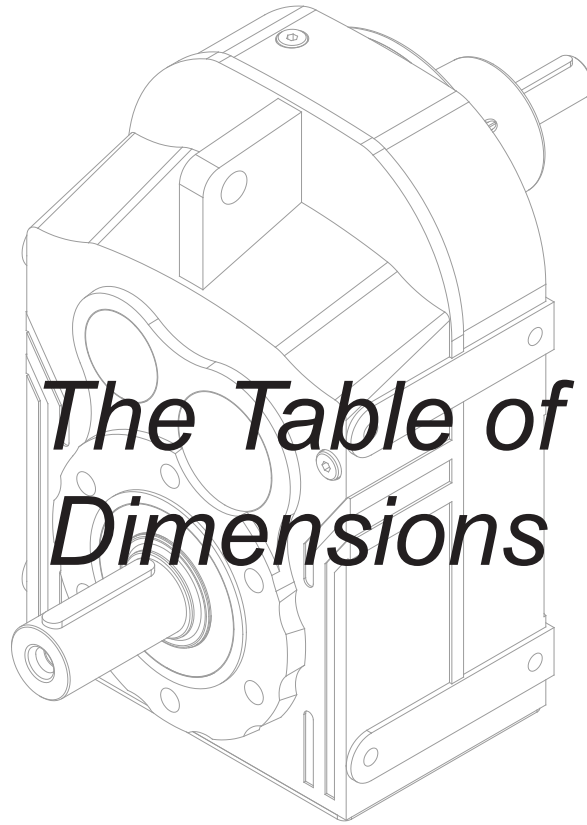

## Abmessungs- tabellen

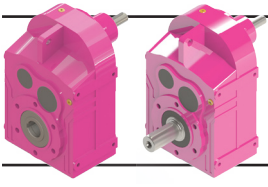

# Ölçü Sayfaları

## Dimension Pages

## Abmessungsseiten

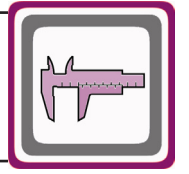

DT072.00  
DT073.00

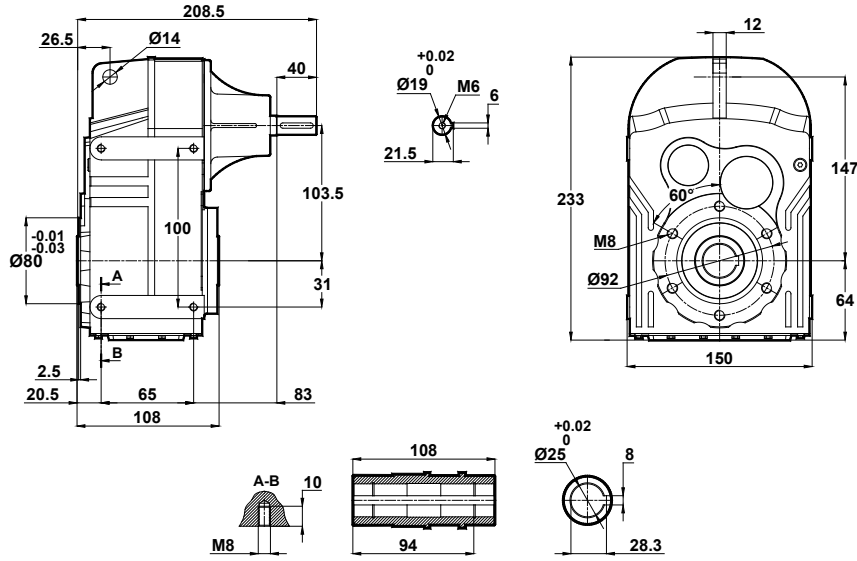

DT072.01  
DT073.01

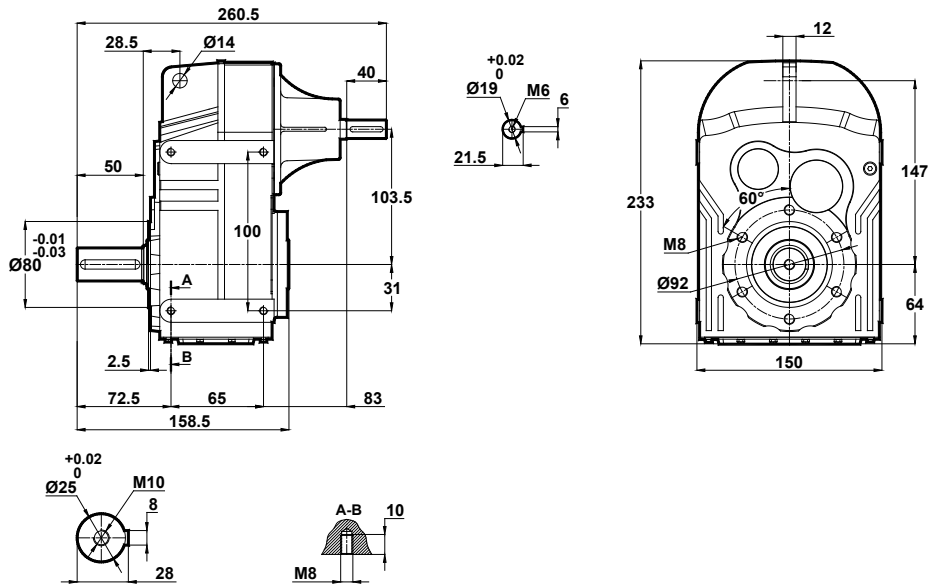

-Mil ucu çekirme deliği DIN 332 sayfa 2 / Tapped center hole according to DIN 332, sheet 2 / Zentrierung mit Gewinde nach DIN 332, Blatt 2

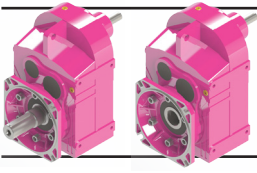

# Ölçü Sayfaları

## Dimension Pages

### Abmessungsseiten

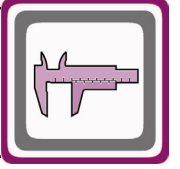

DT072.02  
DT073.02

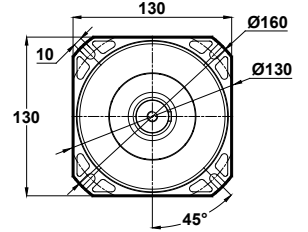
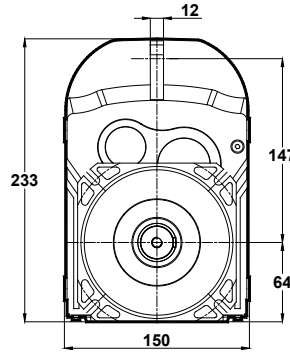
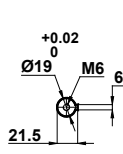
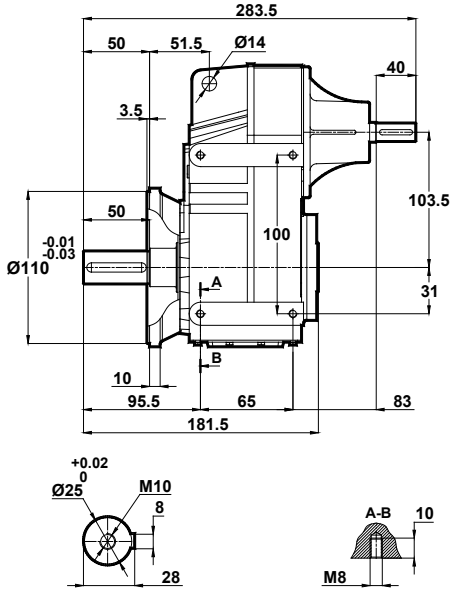

Opsiyonel Flanş Ölçüleri  
Optional Flange Dimensions  
Auswählbare Flanschabmessungen

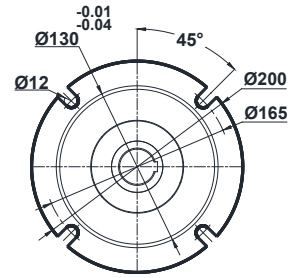

DT072.03  
DT073.03

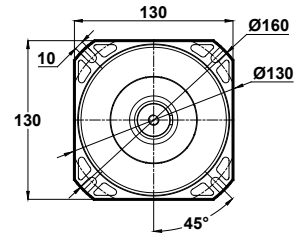
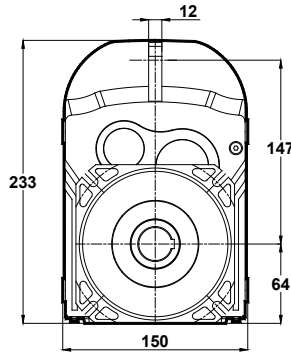
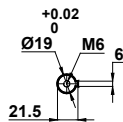
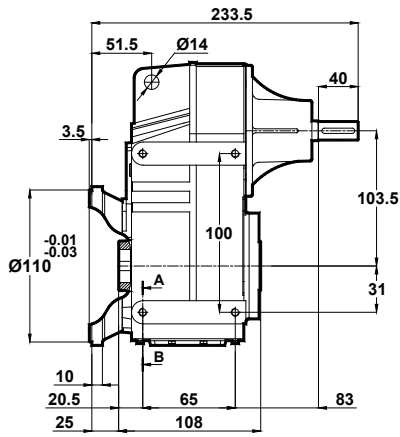

Opsiyonel Flanş Ölçüleri  
Optional Flange Dimensions  
Auswählbare Flanschabmessungen

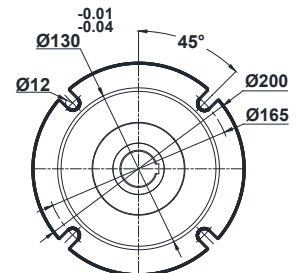
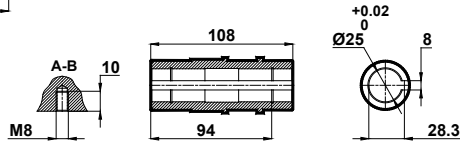

-Mil ucu çektirme deliği DIN 332 sayfa 2 / Tapped center hole according to DIN 332, sheet 2 / Zentrierung mit Gewinde nach DIN 332, Blatt 2

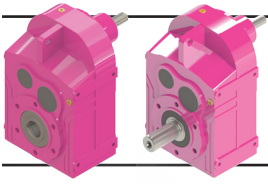

# Ölçü Sayfaları

## Dimension Pages

## Abmessungsseiten

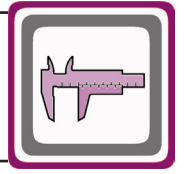

DT172.00  
DT173.00

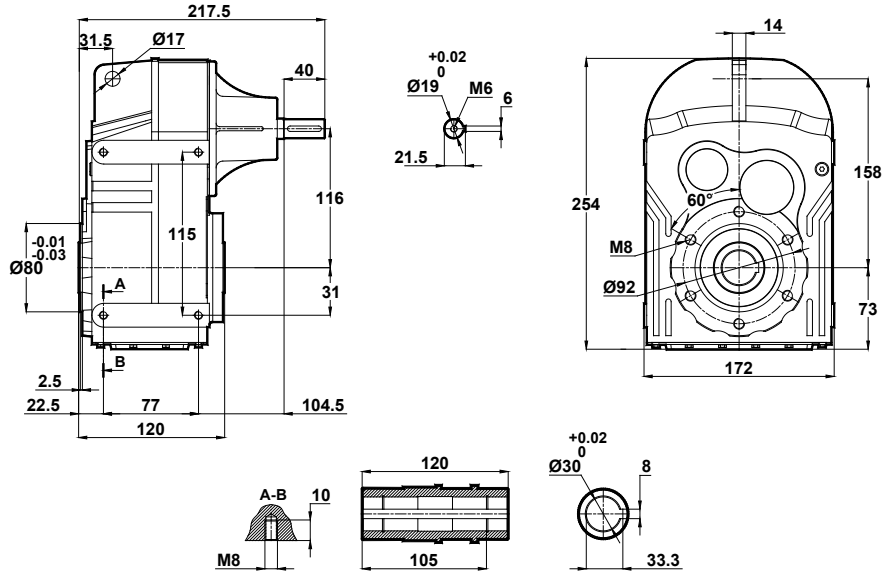

DT172.01  
DT173.01

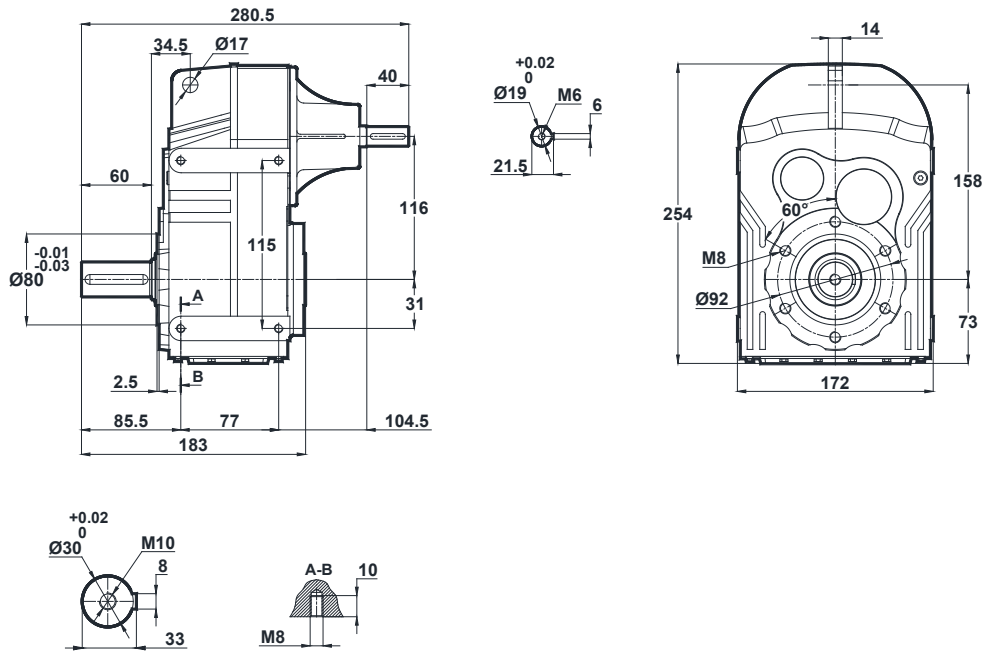

-Mil ucu çekirme deliği DIN 332 sayfa 2 / Tapped center hole according to DIN 332, sheet 2 / Zentrierung mit Gewinde nach DIN 332, Blatt 2

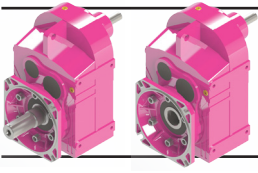

# Ölçü Sayfaları

## Dimension Pages

### Abmessungsseiten

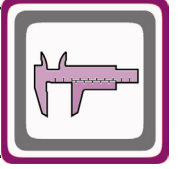

DT172.02  
DT173.02

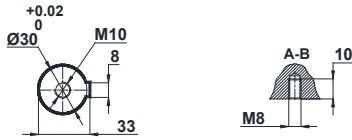
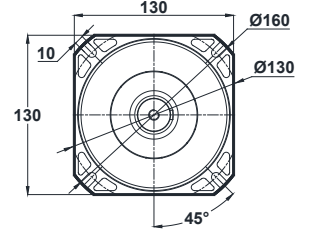
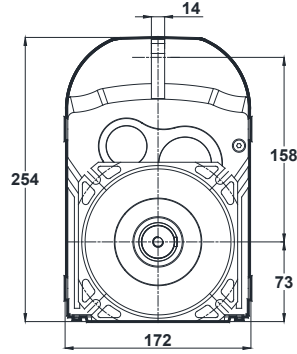
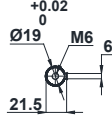
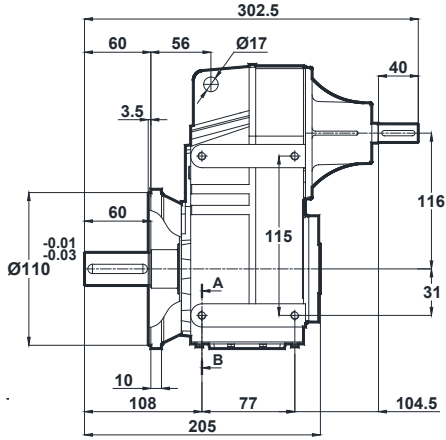

Opsiyonel Flanş Ölçüleri  
Optional Flange Dimensions  
Auswählbare Flanschabmessungen

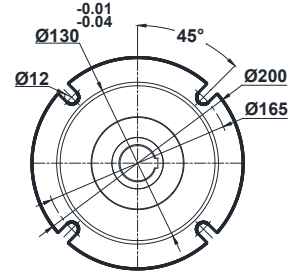

DT172.03  
DT173.03

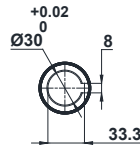
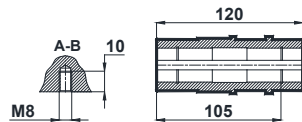
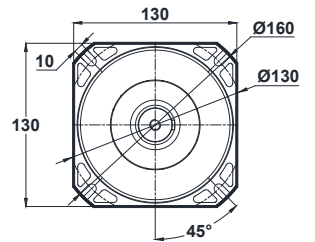
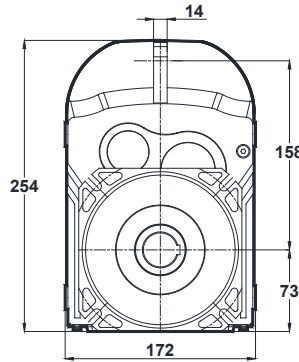
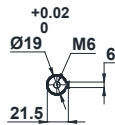
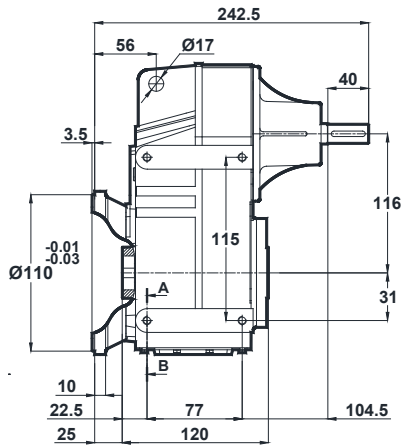

Opsiyonel Flanş Ölçüleri  
Optional Flange Dimensions  
Auswählbare Flanschabmessungen

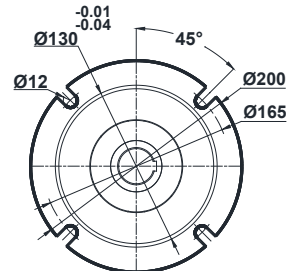

-Mil ucu çektirme deliği DIN 332 sayfa 2 / Tapped center hole according to DIN 332, sheet 2 / Zentrierung mit Gewinde nach DIN 332, Blatt 2

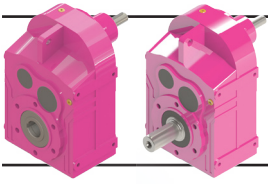

# Ölçü Sayfaları

## Dimension Pages

## Abmessungsseiten

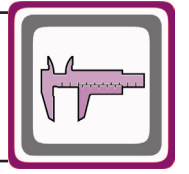

DT272.00  
DT273.00

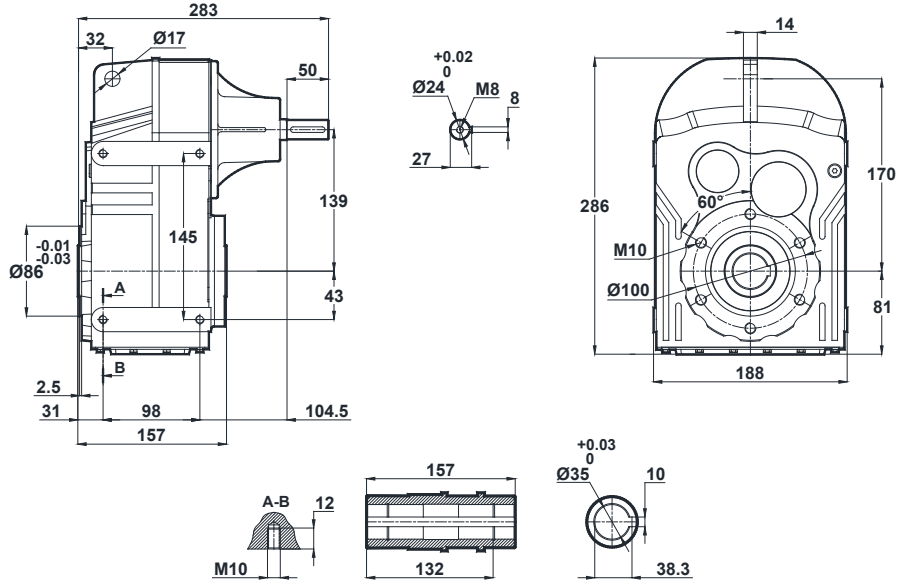

DT272.01  
DT273.01

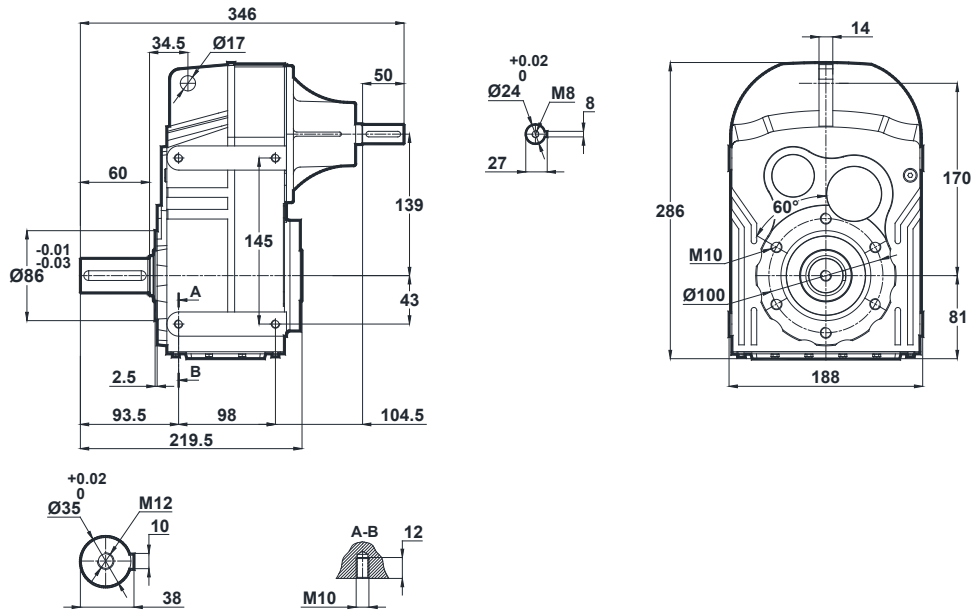

-Mil ucu çekirme deliği DIN 332 sayfa 2 / Tapped center hole according to DIN 332, sheet 2 / Zentrierung mit Gewinde nach DIN 332, Blatt 2

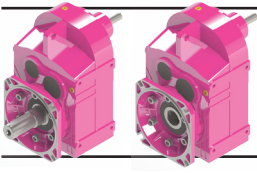

# Ölçü Sayfaları

## Dimension Pages

### Abmessungsseiten

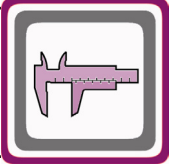

DT272.02  
DT273.02

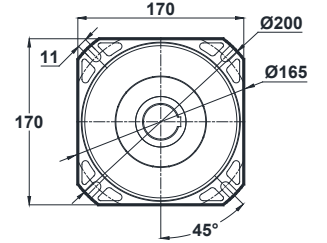
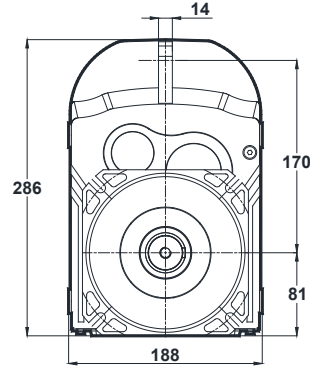
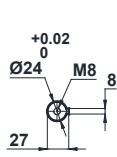
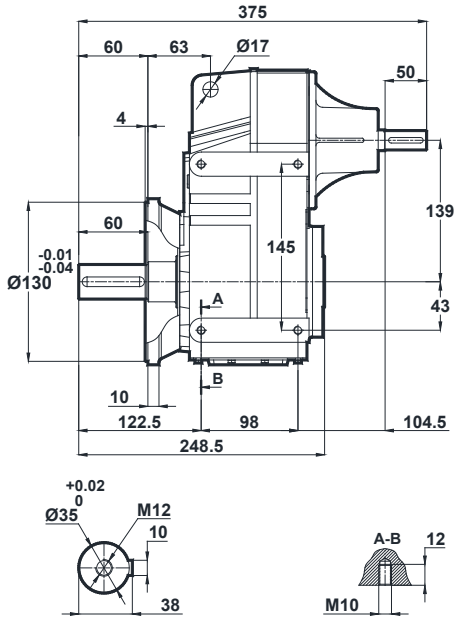

Opsiyonel Flanş Ölçüleri  
Optional Flange Dimensions  
Auswählbare Flanschabmessungen

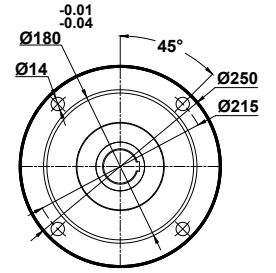

DT272.03  
DT273.03

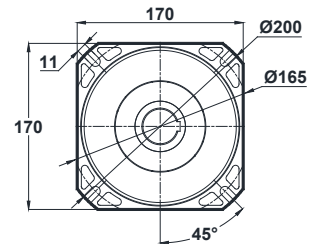
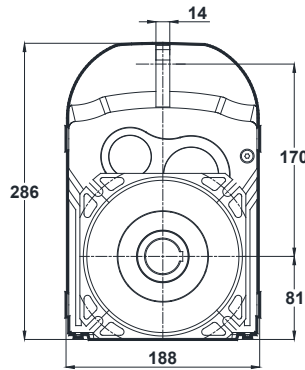
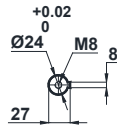
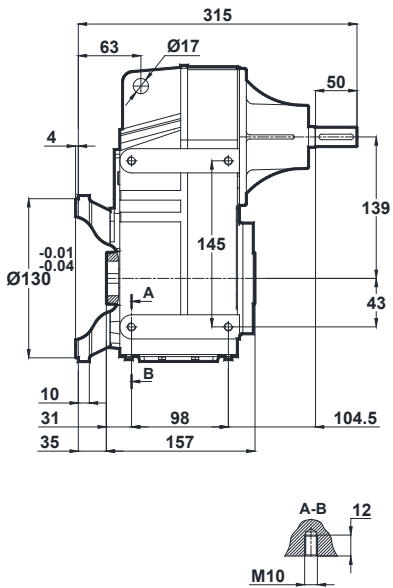

Opsiyonel Flanş Ölçüleri  
Optional Flange Dimensions  
Auswählbare Flanschabmessungen

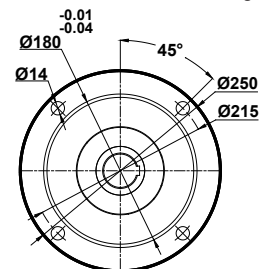

-Mil ucu çektirme deliği DIN 332 sayfa 2 / Tapped center hole according to DIN 332, sheet 2 / Zentrierung mit Gewinde nach DIN 332, Blatt 2

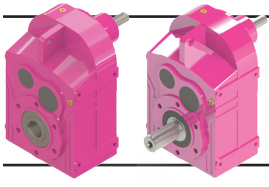

# Ölçü Sayfaları

## Dimension Pages

### Abmessungsseiten

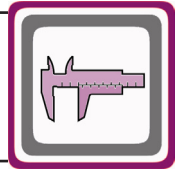

DT275.00  
DT276.00

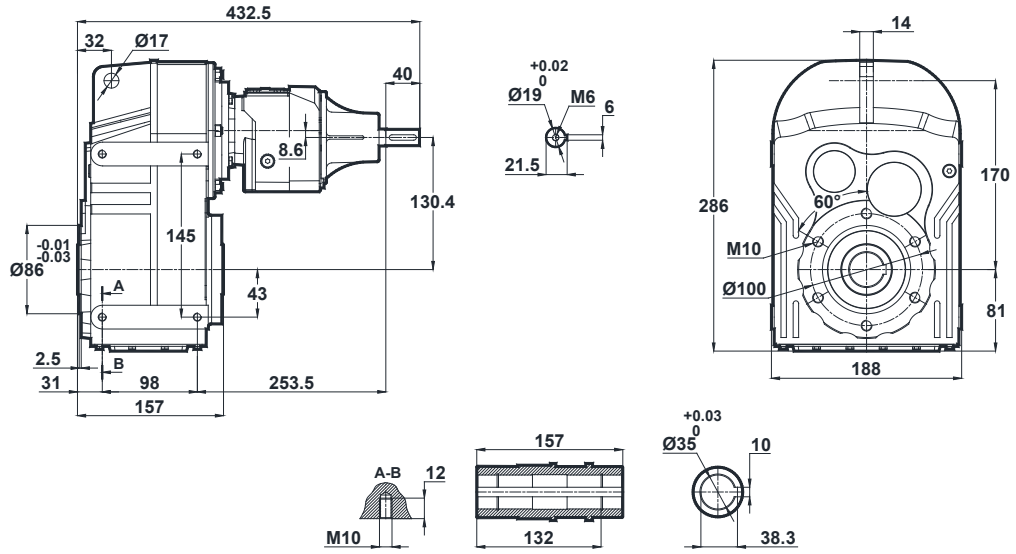

DT275.01  
DT276.01

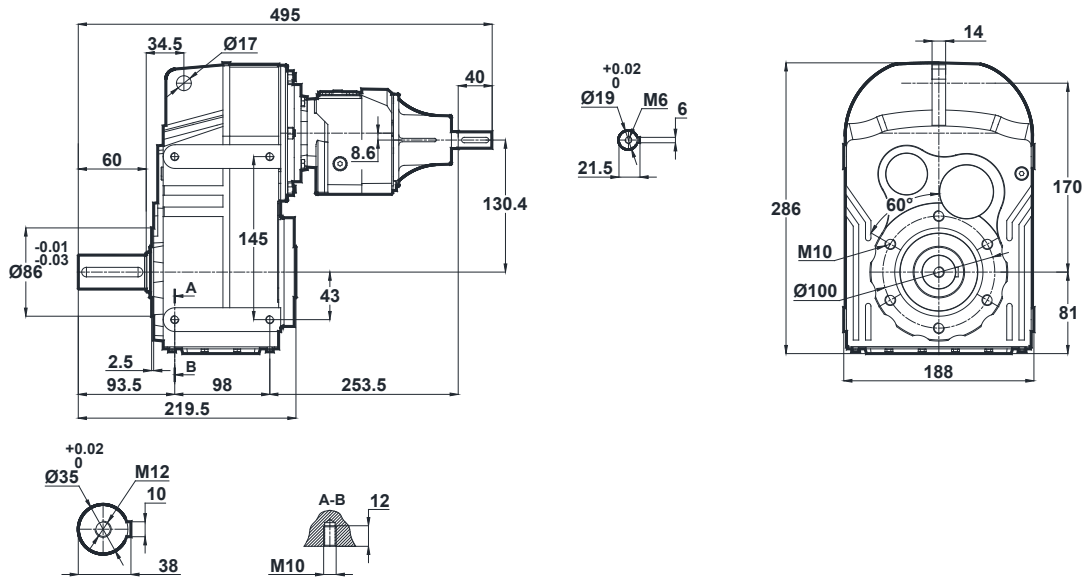

-Mil ucu çekirme deliği DIN 332 sayfa 2 / Tapped center hole according to DIN 332, sheet 2 / Zentrierung mit Gewinde nach DIN 332, Blatt 2

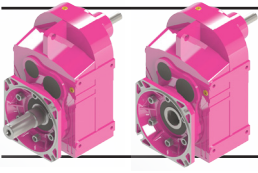

# Ölçü Sayfaları

## Dimension Pages

### Abmessungsseiten

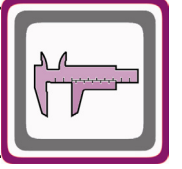

DT275.02  
DT276.02

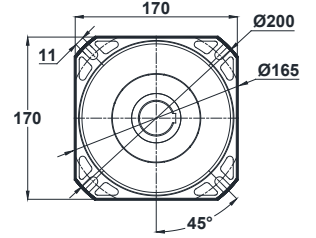
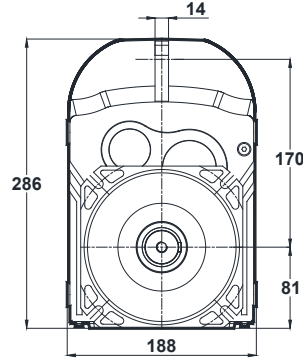
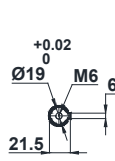
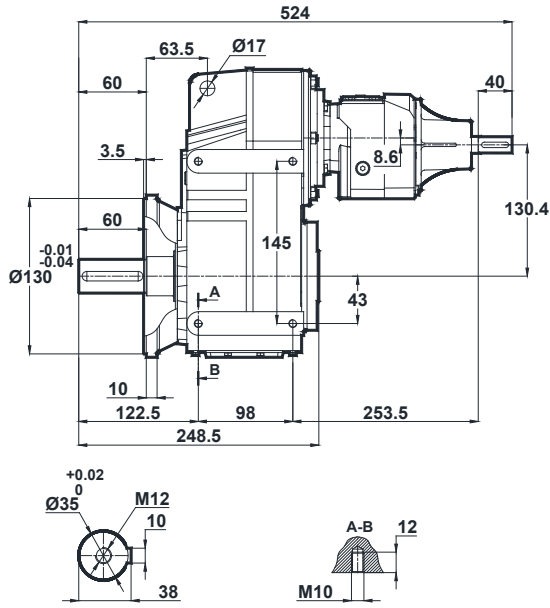

Opsiyonel Flanş Ölçüleri  
Optional Flange Dimensions  
Auswählbare Flanschabmessungen

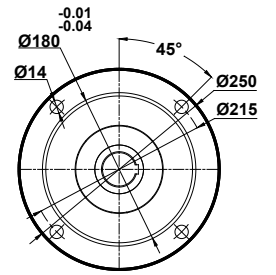

DT275.03  
DT276.03

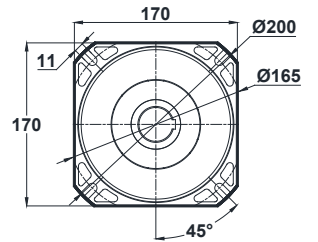
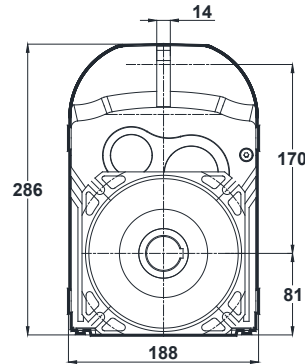
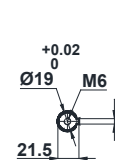
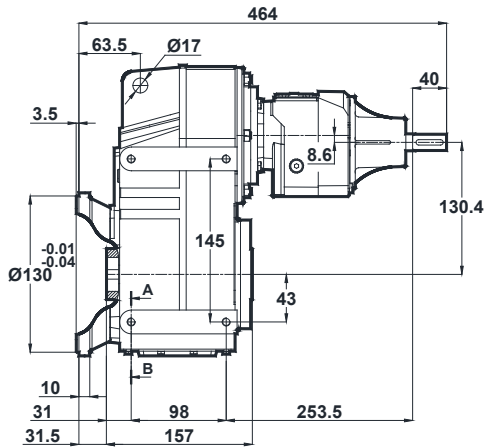

Opsiyonel Flanş Ölçüleri  
Optional Flange Dimensions  
Auswählbare Flanschabmessungen

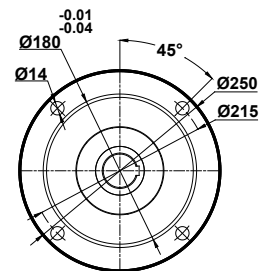

-Mil ucu çektirme deliği DIN 332 sayfa 2 / Tapped center hole according to DIN 332, sheet 2 / Zentrierung mit Gewinde nach DIN 332, Blatt 2

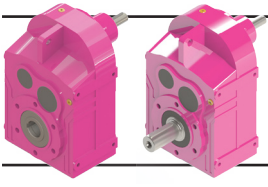

# Ölçü Sayfaları

## Dimension Pages

## Abmessungsseiten

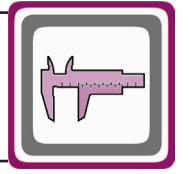

DT282.00  
DT283.00

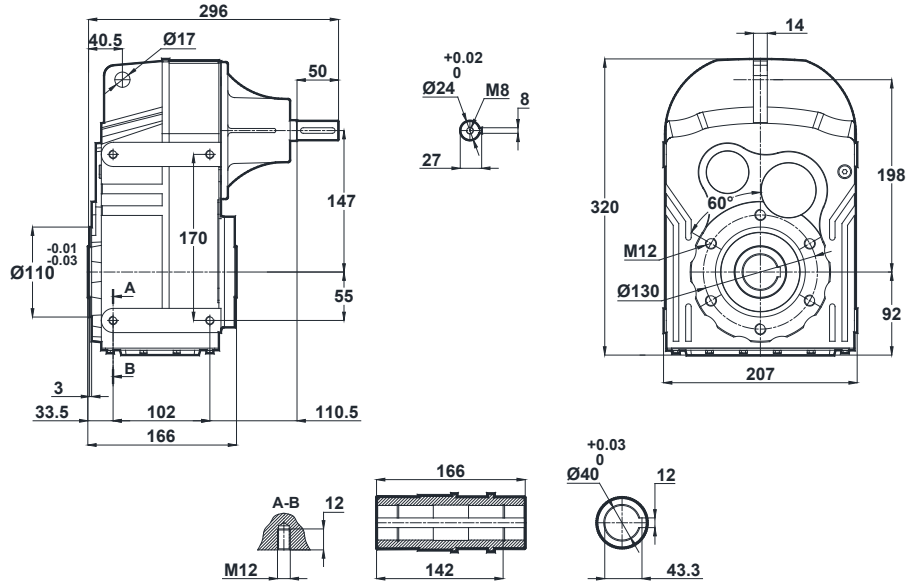

DT282.01  
DT283.01

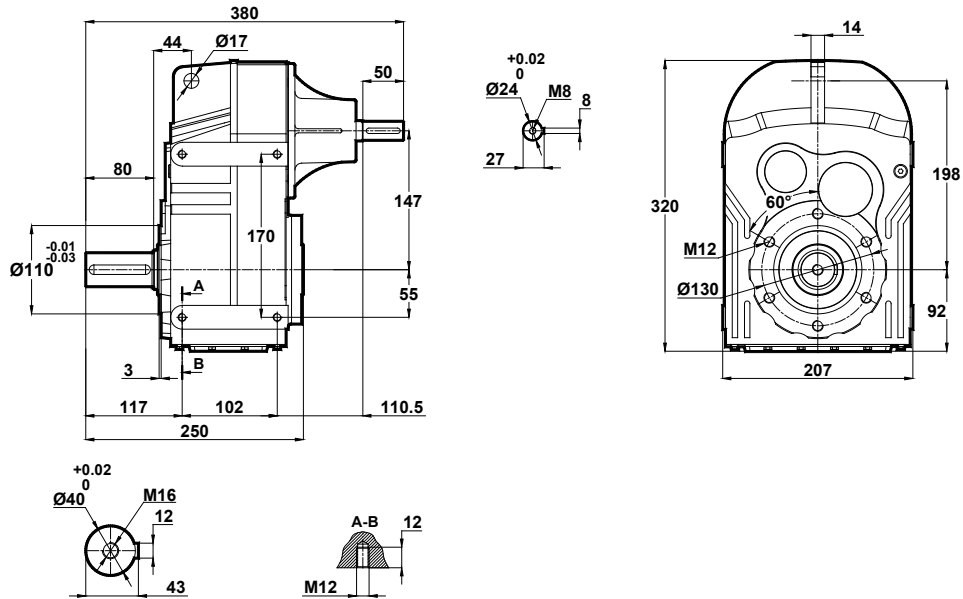

-Mil ucu çekirme deliği DIN 332 sayfa 2 / Tapped center hole according to DIN 332, sheet 2 / Zentrierung mit Gewinde nach DIN 332, Blatt 2

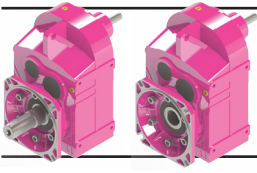

# Ölçü Sayfaları Dimension Pages Abmessungsseiten

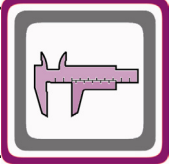

DT282.02  
DT283.02

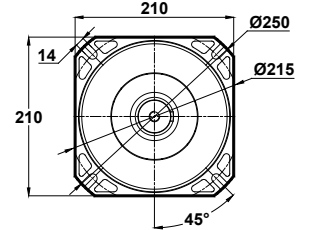
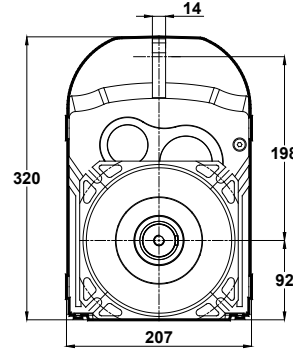
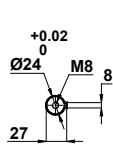
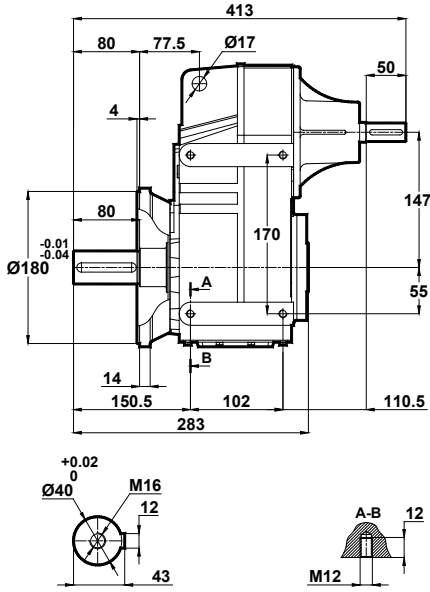

Opsiyonel Flanş Ölçüleri  
Optional Flange Dimensions  
Auswählbare Flanschabmessungen

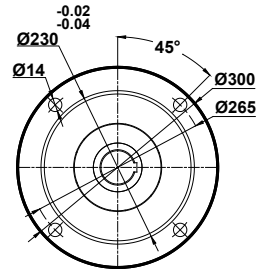

Diğer opsiyonel flanş ölçüleri için sayfa 326'ya bakınız.  
Please see on page 326 for other optional flange dimensions  
Siehe Seite 326 für andere auswählbare Flanschabmessungen

DT282.03  
DT283.03

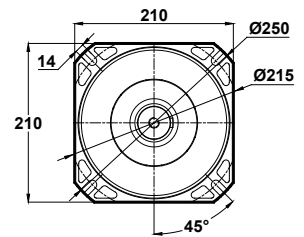
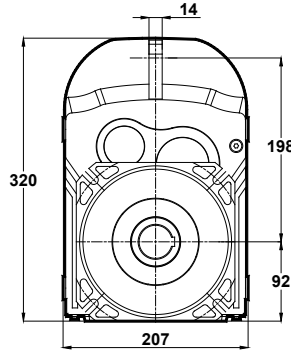
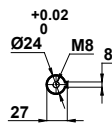
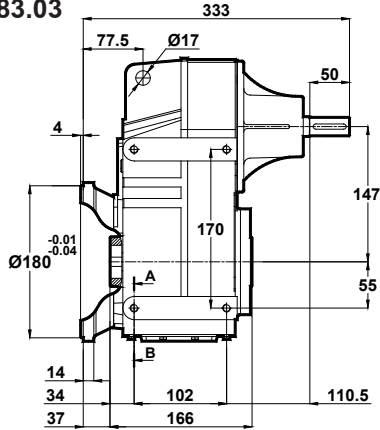

Opsiyonel Flanş Ölçüleri  
Optional Flange Dimensions  
Auswählbare Flanschabmessungen

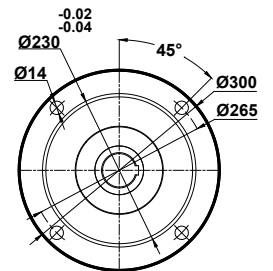
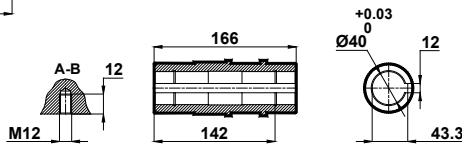

Diğer opsiyonel flanş ölçüleri için sayfa 326'ya bakınız.  
Please see on page 326 for other optional flange dimensions  
Siehe Seite 326 für andere auswählbare Flanschabmessungen

-Mil ucu çektirme deliği DIN 332 sayfa 2 / Tapped center hole according to DIN 332, sheet 2 / Zentrierung mit Gewinde nach DIN 332, Blatt 2

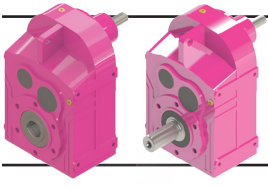

# Ölçü Sayfaları

## Dimension Pages

## Abmessungsseiten

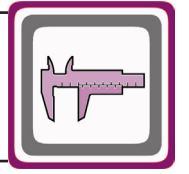

DT285.00  
DT286.00

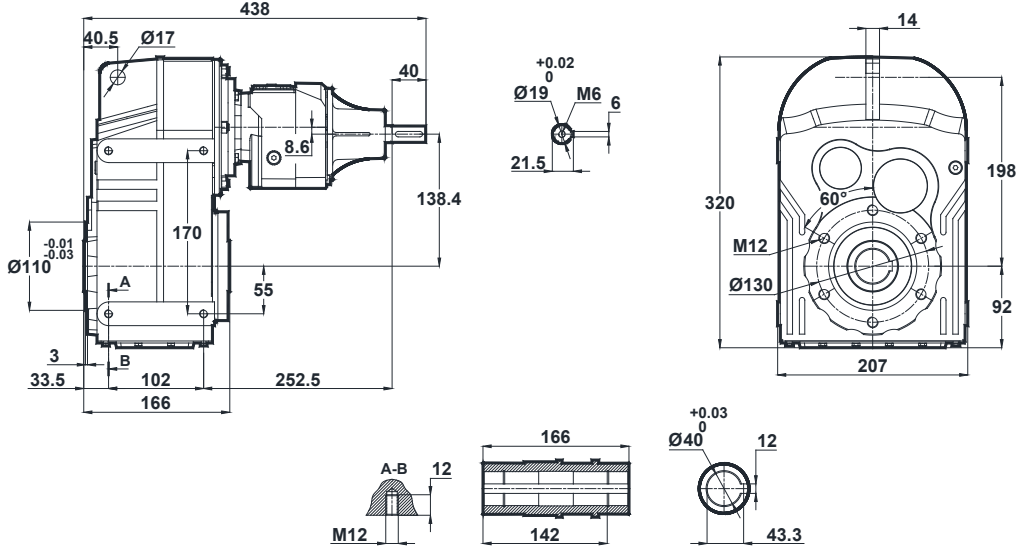

DT285.01  
DT286.01

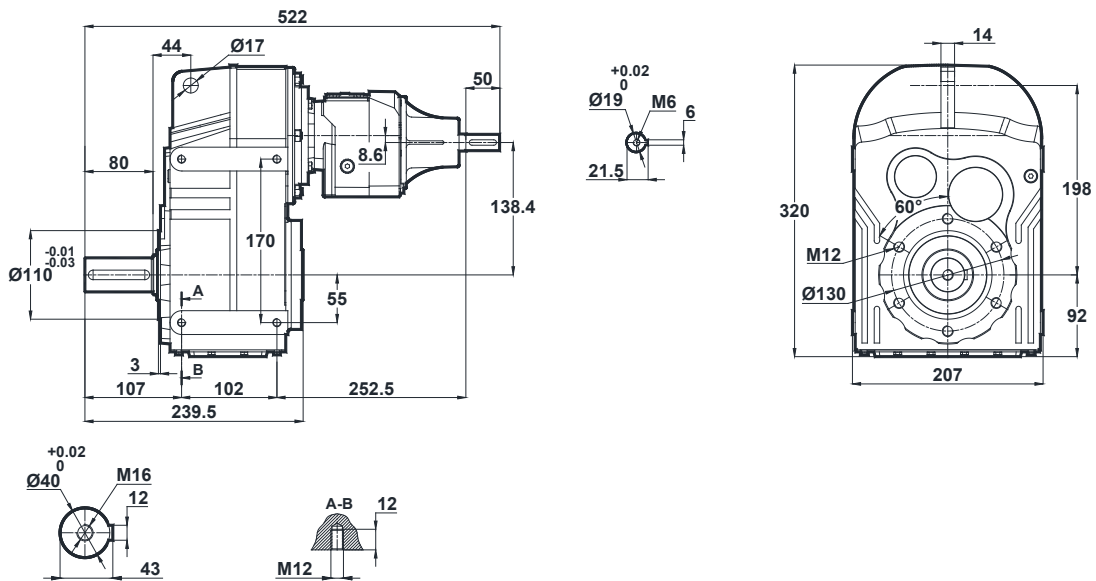

-Mil ucu çekirme deliği DIN 332 sayfa 2 / Tapped center hole according to DIN 332, sheet 2 / Zentrierung mit Gewinde nach DIN 332, Blatt 2

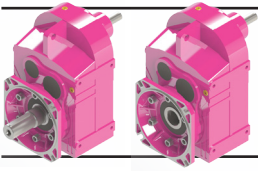

# Ölçü Sayfaları Dimension Pages Abmessungenseiten

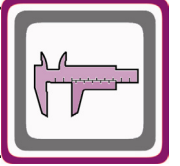

DT285.02  
DT286.02

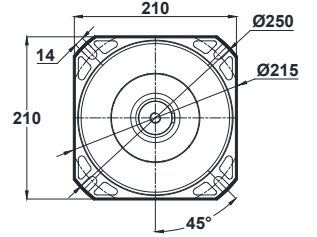
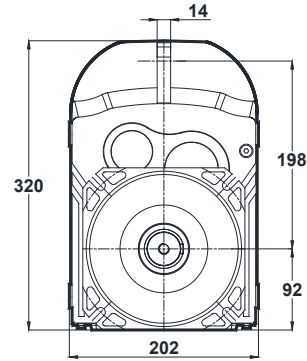
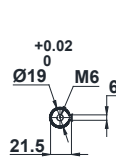
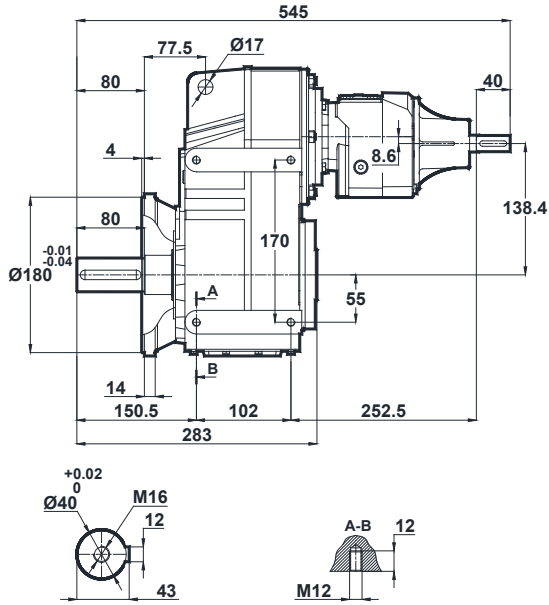

Opsiyonel Flanş Ölçüleri  
Optional Flange Dimensions  
Auswählbare Flanschabmessungen

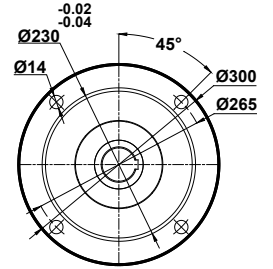

Diğer opsiyonel flanş ölçüleri için sayfa 326'ya bakınız.  
Please see on page 326 for other optional flange dimensions  
Siehe Seite 326 für andere auswählbare Flanschabmessungen

DT285.03  
DT286.03

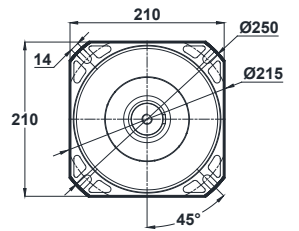
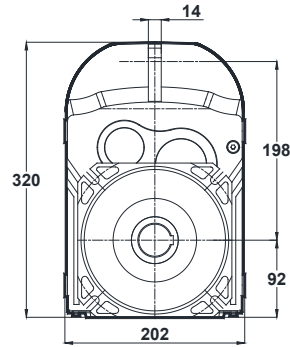
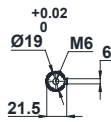
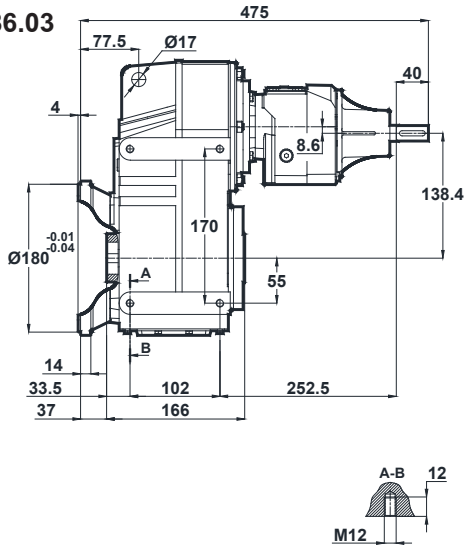

Opsiyonel Flanş Ölçüleri  
Optional Flange Dimensions  
Auswählbare Flanschabmessungen

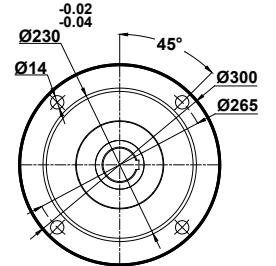

Diğer opsiyonel flanş ölçüleri için sayfa 326'ya bakınız.  
Please see on page 326 for other optional flange dimensions  
Siehe Seite 326 für andere auswählbare Flanschabmessungen

-Mil ucu çektirme deliği DIN 332 sayfa 2 / Tapped center hole according to DIN 332, sheet 2 / Zentrierung mit Gewinde nach DIN 332, Blatt 2

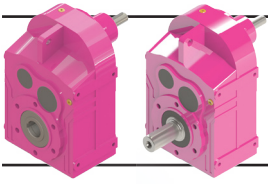

# Ölçü Sayfaları

## Dimension Pages

## Abmessungsseiten

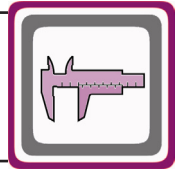

DT372.00  
DT373.00

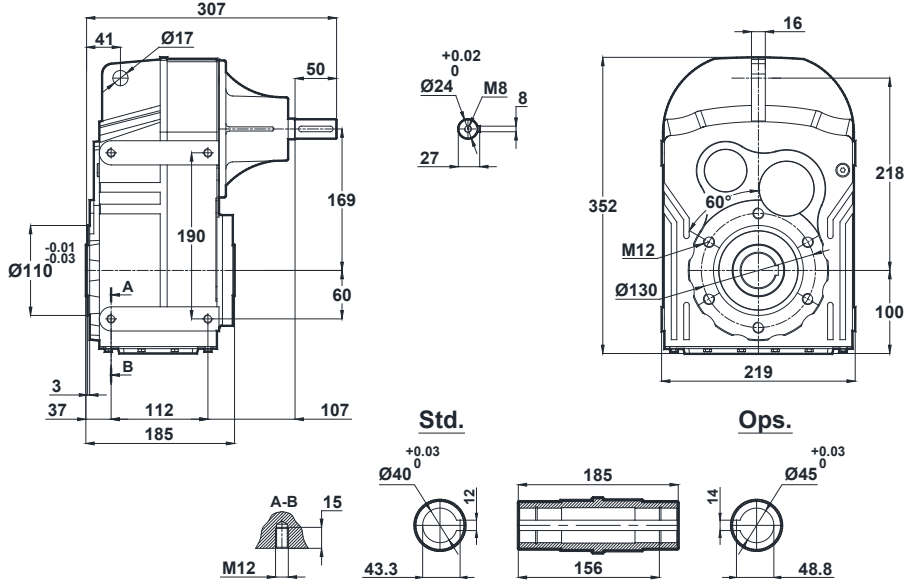

DT372.01  
DT373.01

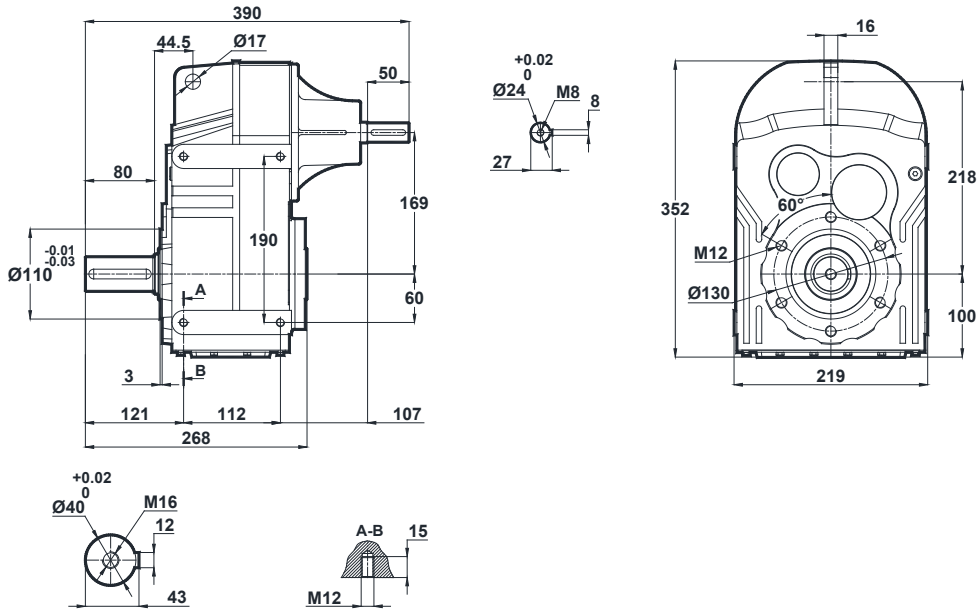

-Mil ucu çekirme deliği DIN 332 sayfa 2 / Tapped center hole according to DIN 332, sheet 2 / Zentrierung mit Gewinde nach DIN 332, Blatt 2

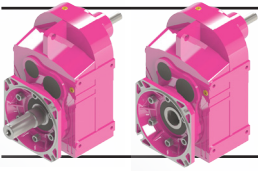

# Ölçü Sayfaları Dimension Pages Abmessungenseiten

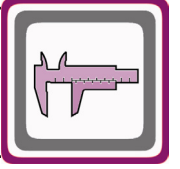

DT372.02  
DT373.02

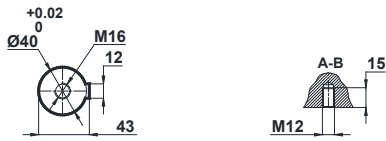
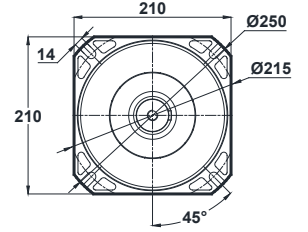
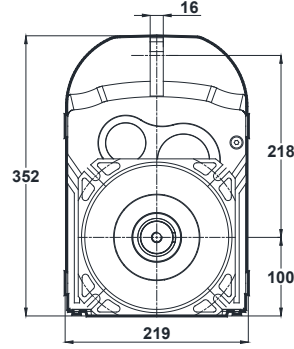
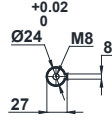
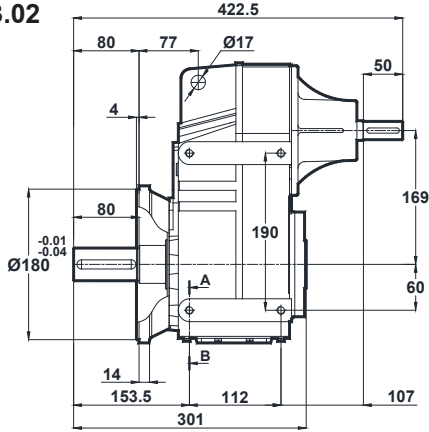

Opsiyonel Flanş Ölçüleri  
Optional Flange Dimensions  
Auswählbare Flanschabmessungen

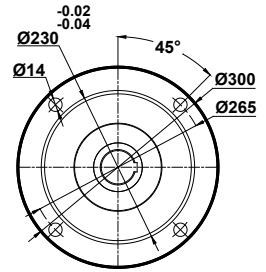

Diğer opsiyonel flanş ölçüleri için sayfa 326'ya bakınız.  
Please see on page 326 for other optional flange dimensions  
Siehe Seite 326 für andere auswählbare Flanschabmessungen

DT372.03  
DT373.03

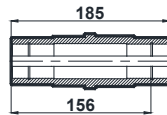
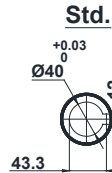
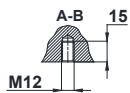
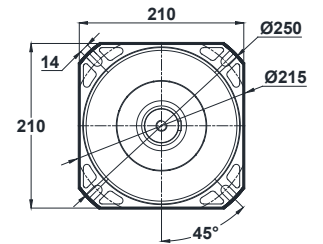
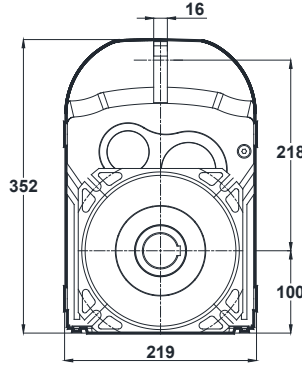
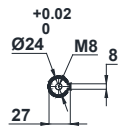
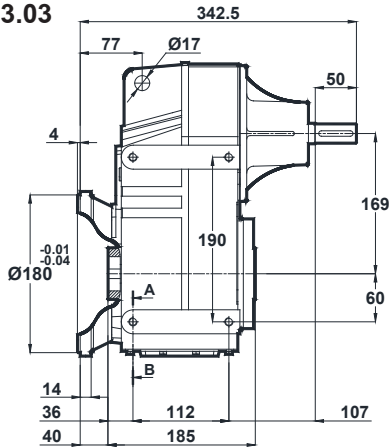

Opsiyonel Flanş Ölçüleri  
Optional Flange Dimensions  
Auswählbare Flanschabmessungen

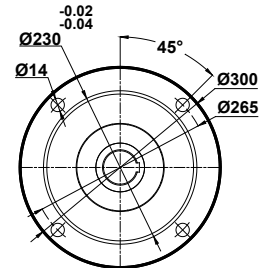

Diğer opsiyonel flanş ölçüleri için sayfa 326'ya bakınız.  
Please see on page 326 for other optional flange dimensions  
Siehe Seite 326 für andere auswählbare Flanschabmessungen

-Mil ucu çektirme deliği DIN 332 sayfa 2 / Tapped center hole according to DIN 332, sheet 2 / Zentrierung mit Gewinde nach DIN 332, Blatt 2

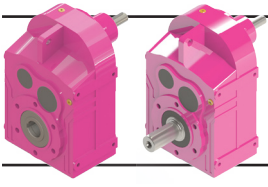

# Ölçü Sayfaları

## Dimension Pages

## Abmessungenseiten

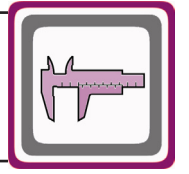

DT375.00  
DT376.00

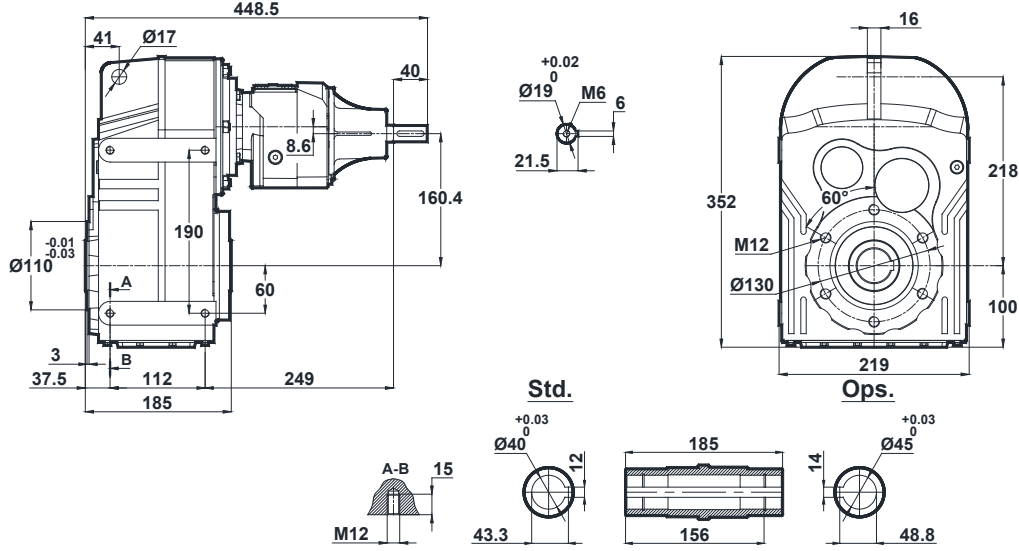

DT375.01  
DT376.01

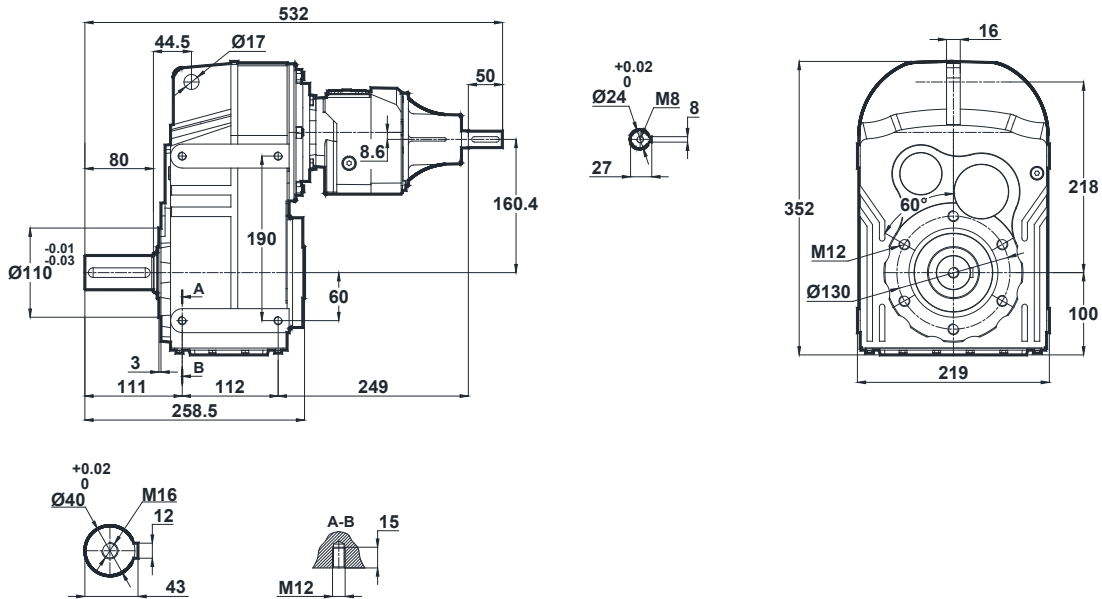

-Mil ucu çekirme deliği DIN 332 sayfa 2 / Tapped center hole according to DIN 332, sheet 2 / Zentrierung mit Gewinde nach DIN 332, Blatt 2

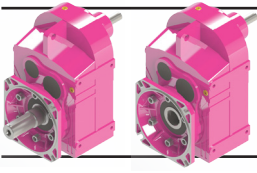

# Ölçü Sayfaları Dimension Pages Abmessungsseiten

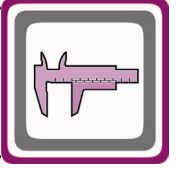

DT375.02  
DT376.02

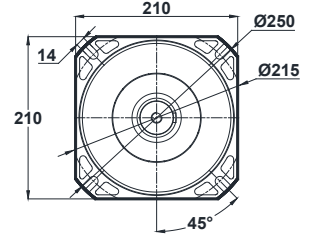
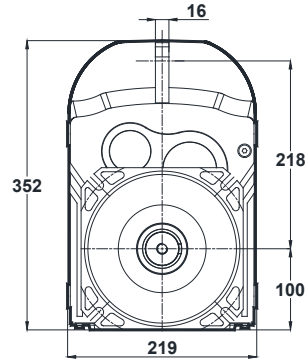
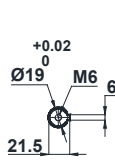
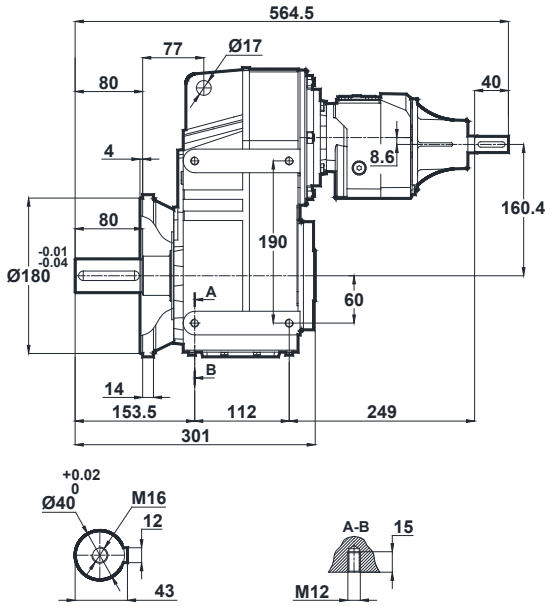

Opsiyonel Flanş Ölçüleri  
Optional Flange Dimensions  
Auswählbare Flanschabmessungen

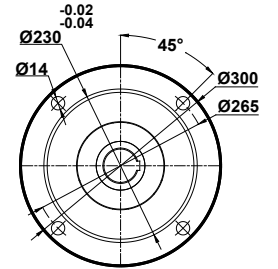

Diğer opsiyonel flanş ölçüleri için sayfa 326'ya bakınız.  
Please see on page 326 for other optional flange dimensions  
Siehe Seite 326 für andere auswählbare Flanschabmessungen

DT375.03  
DT376.03

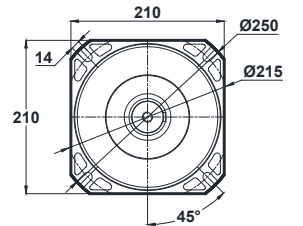
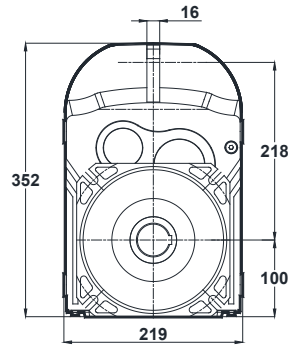
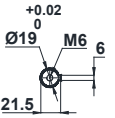
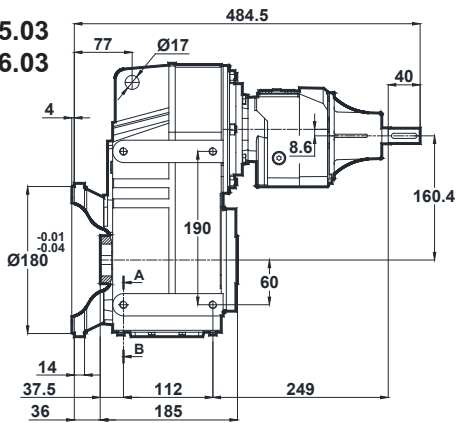

Opsiyonel Flanş Ölçüleri  
Optional Flange Dimensions  
Auswählbare Flanschabmessungen

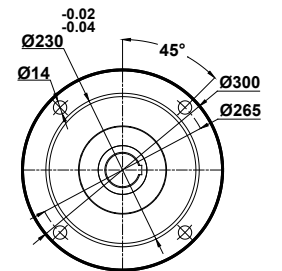
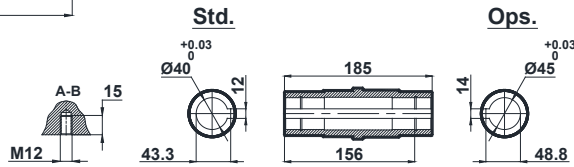

Diğer opsiyonel flanş ölçüleri için sayfa 326'ya bakınız.  
Please see on page 326 for other optional flange dimensions  
Siehe Seite 326 für andere auswählbare Flanschabmessungen

-Mil ucu çektirme deliği DIN 332 sayfa 2 / Tapped center hole according to DIN 332, sheet 2 / Zentrierung mit Gewinde nach DIN 332, Blatt 2

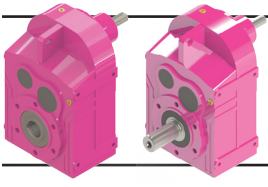

# Ölçü Sayfaları

## Dimension Pages

## Abmessungsseiten

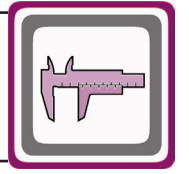

DT472.00  
DT473.00

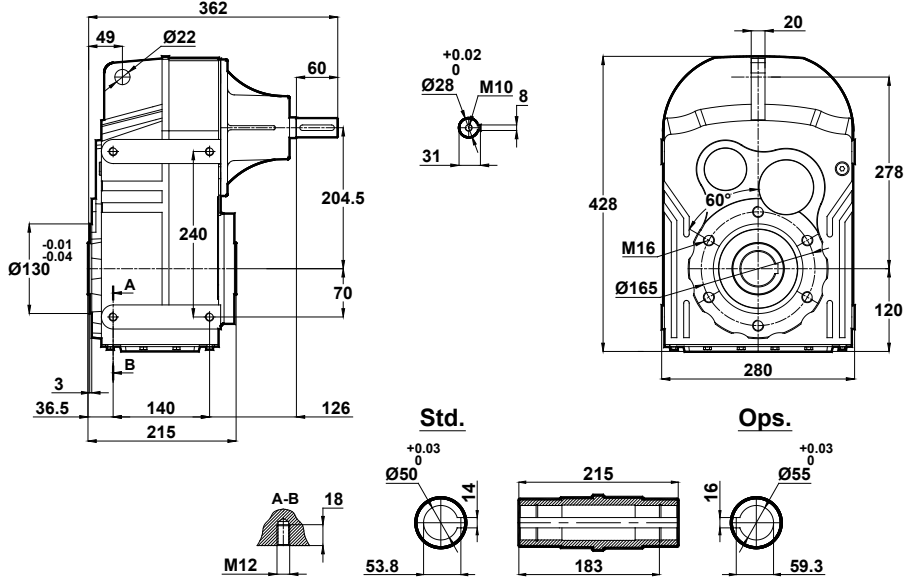

DT472.01  
DT473.01

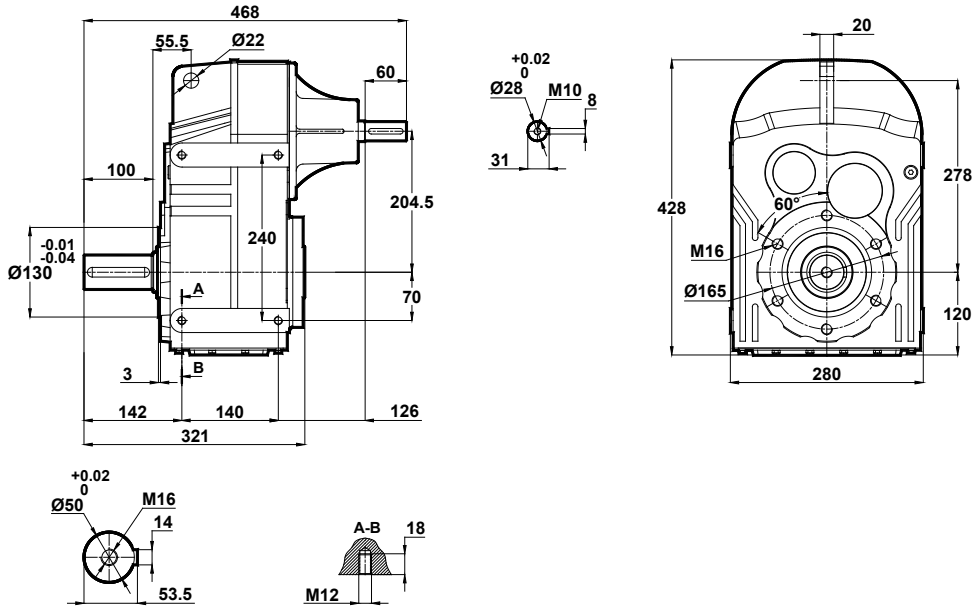

-Mil ucu çekirme deliği DIN 332 sayfa 2 / Tapped center hole according to DIN 332, sheet 2 / Zentrierung mit Gewinde nach DIN 332, Blatt 2

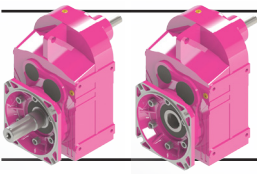

# Ölçü Sayfaları Dimension Pages Abmessungenseiten

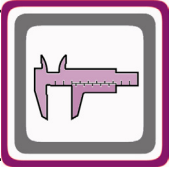

DT472.02  
DT473.02

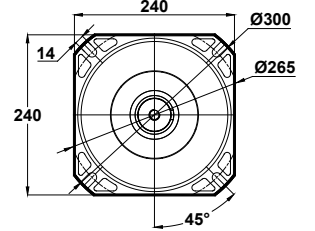
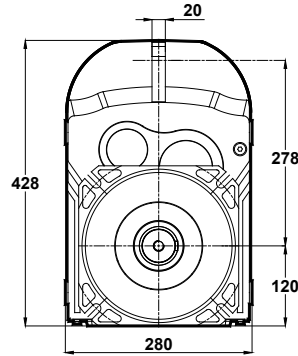
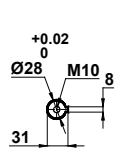
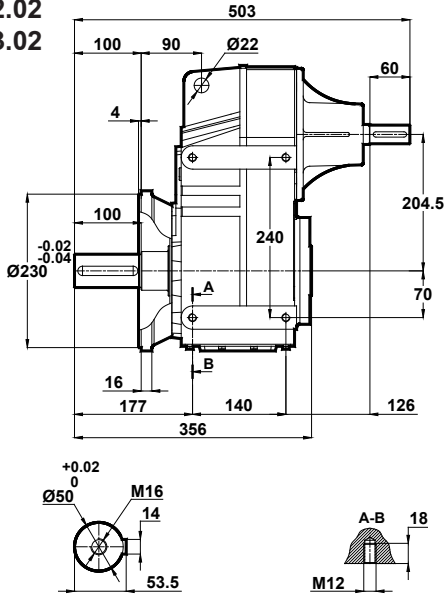

Opsiyonel Flanş Ölçüleri  
Optional Flange Dimensions  
Auswählbare Flanschabmessungen

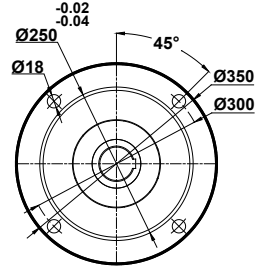

Diğer opsiyonel flanş ölçüleri için sayfa 326'ya bakınız.  
Please see on page 326 for other optional flange dimensions  
Siehe Seite 326 für andere auswählbare Flanschabmessungen

DT472.03  
DT473.03

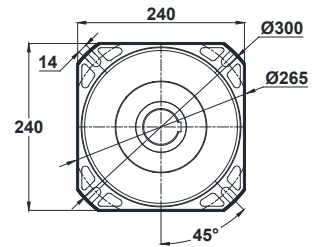
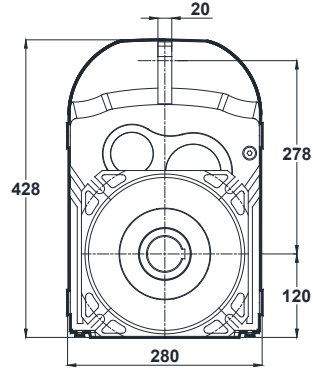
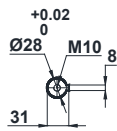
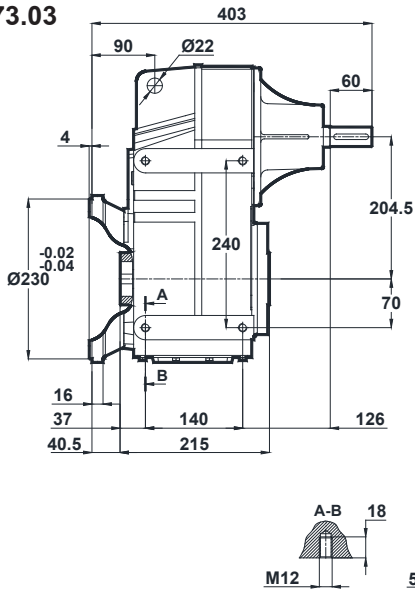

Opsiyonel Flanş Ölçüleri  
Optional Flange Dimensions  
Auswählbare Flanschabmessungen

Std.

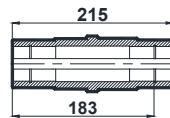
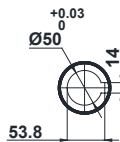

Ops.

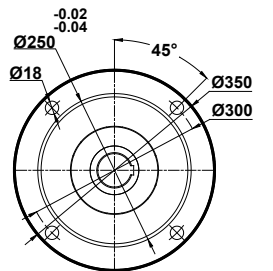
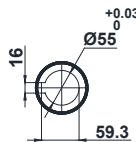

Diğer opsiyonel flanş ölçüleri için sayfa 326'ya bakınız.  
Please see on page 326 for other optional flange dimensions  
Siehe Seite 326 für andere auswählbare Flanschabmessungen

-Mil ucu çektirme deliği DIN 332 sayfa 2 / Tapped center hole according to DIN 332, sheet 2 / Zentrierung mit Gewinde nach DIN 332, Blatt 2

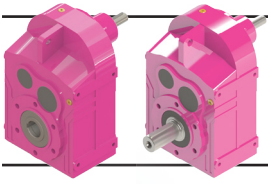

# Ölçü Sayfaları

## Dimension Pages

### Abmessungsseiten

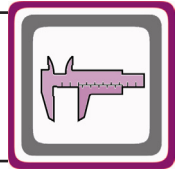

DT474.00

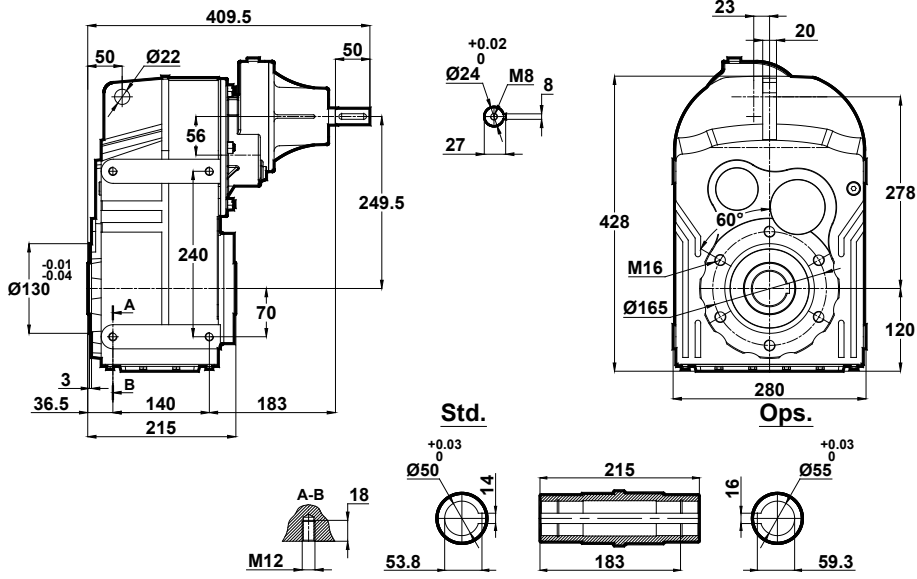

DT474.01

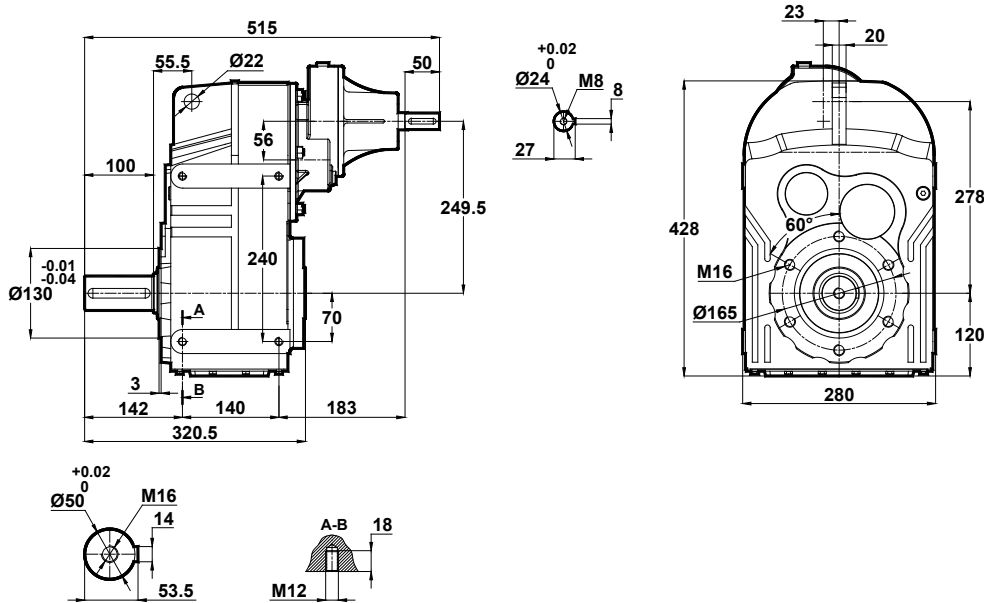

-Mil ucu çekirme deliği DIN 332 sayfa 2 / Tapped center hole according to DIN 332, sheet 2 / Zentrierung mit Gewinde nach DIN 332, Blatt 2

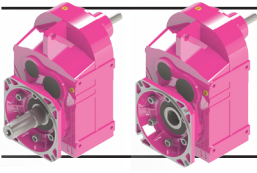

# Ölçü Sayfaları Dimension Pages Abmessungenseiten

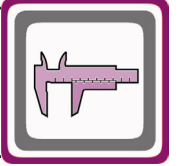

DT474.02

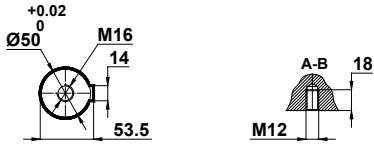
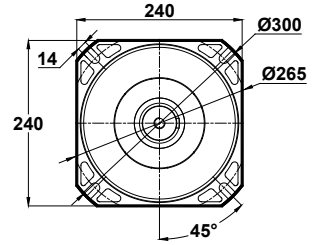
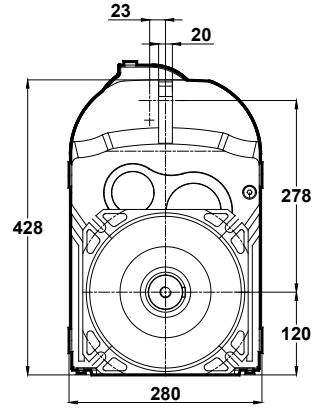
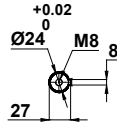
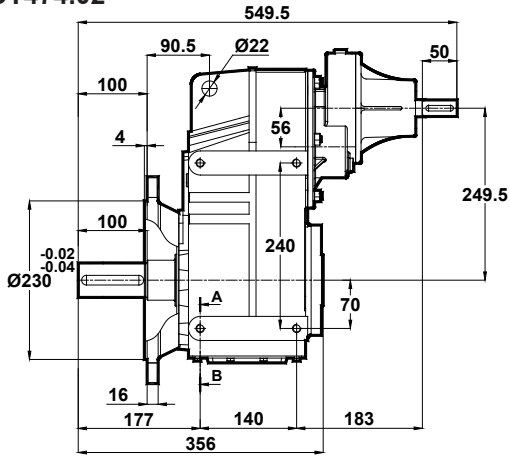

Opsiyonel Flanş Ölçüleri  
Optional Flange Dimensions  
Auswählbare Flanschabmessungen

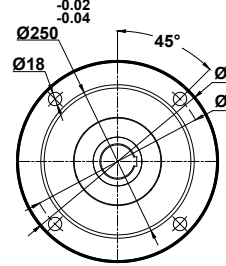

Diğer opsiyonel flanş ölçüleri için sayfa 326'ya bakınız.  
Please see on page 326 for other optional flange dimensions  
Siehe Siete 326 für andere auswählbare Flanschabmessungen

DT474.03

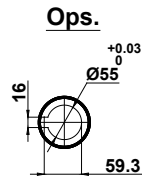
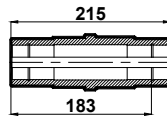
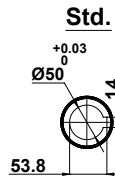
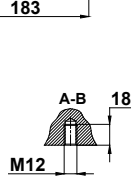
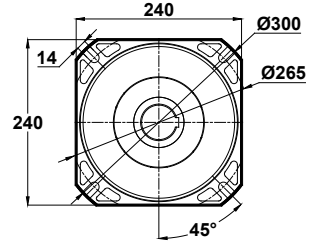
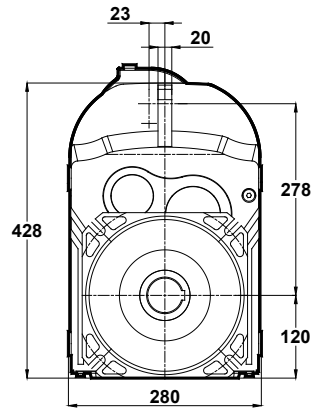
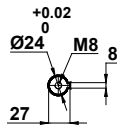
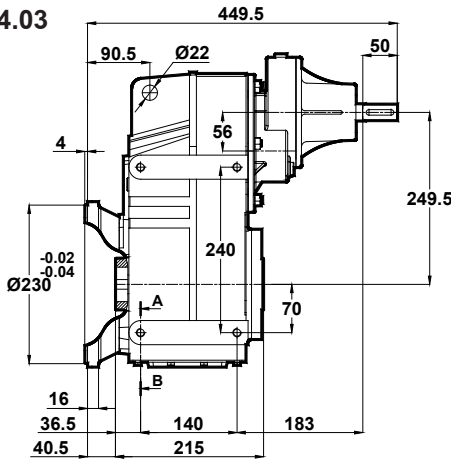

Opsiyonel Flanş Ölçüleri  
Optional Flange Dimensions  
Auswählbare Flanschabmessungen

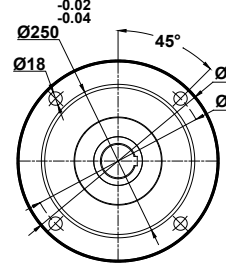

Diğer opsiyonel flanş ölçüleri için sayfa 326'ya bakınız.  
Please see on page 326 for other optional flange dimensions  
Siehe Siete 326 für andere auswählbare Flanschabmessungen

-Mil ucu çektirme deliği DIN 332 sayfa 2 / Tapped center hole according to DIN 332, sheet 2 / Zentrierung mit Gewinde nach DIN 332, Blatt 2

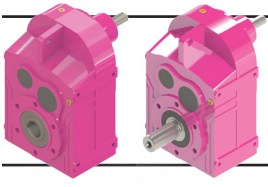

# Ölçü Sayfaları

## Dimension Pages

## Abmessungsseiten

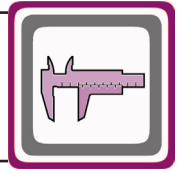

DT475.00  
DT476.00

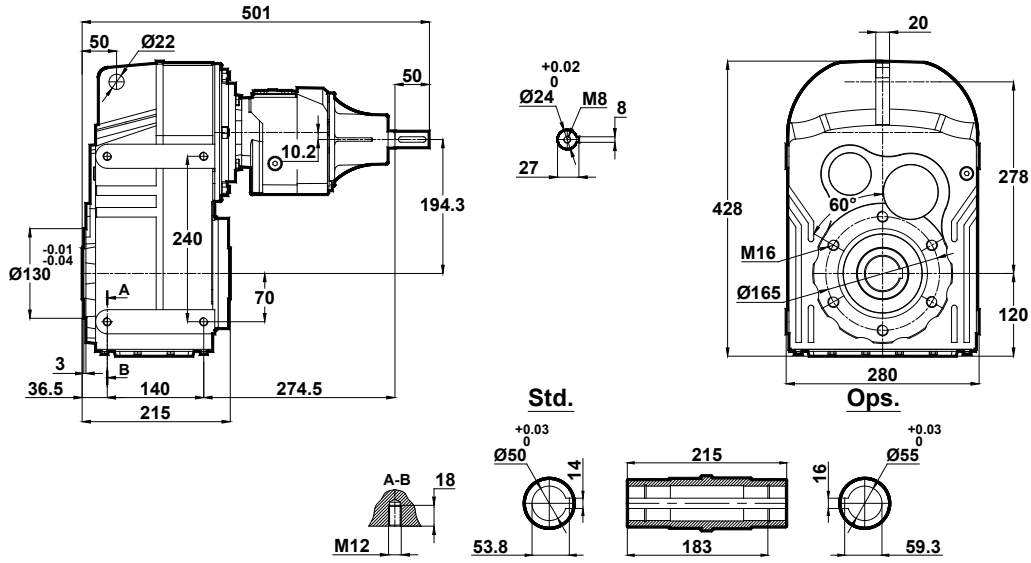

DT475.01  
DT476.01

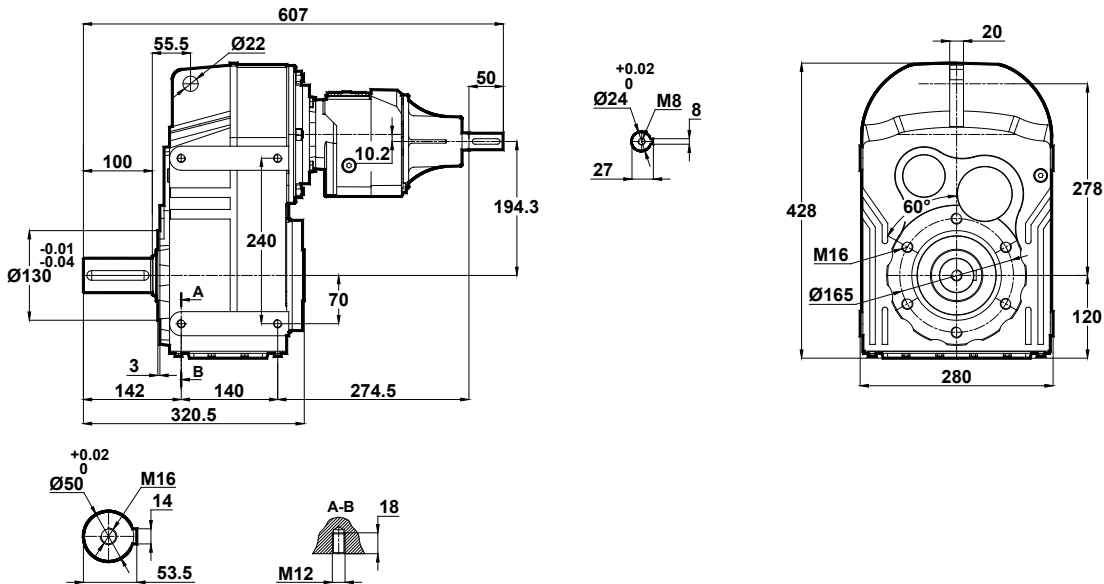

-Mil ucu çekirme deliği DIN 332 sayfa 2 / Tapped center hole according to DIN 332, sheet 2 / Zentrierung mit Gewinde nach DIN 332, Blatt 2

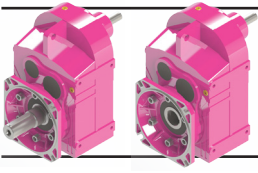

# Ölçü Sayfaları Dimension Pages Abmessungenseiten

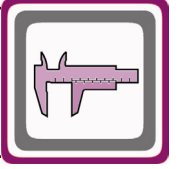

DT475.02  
DT476.02

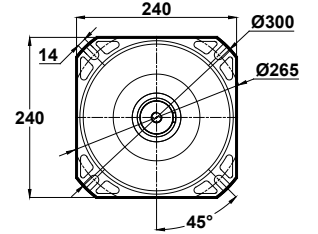
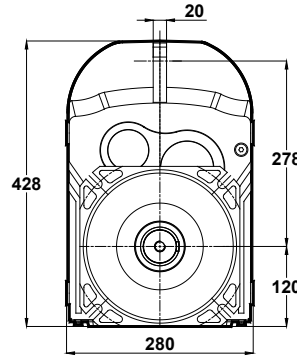
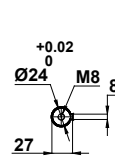
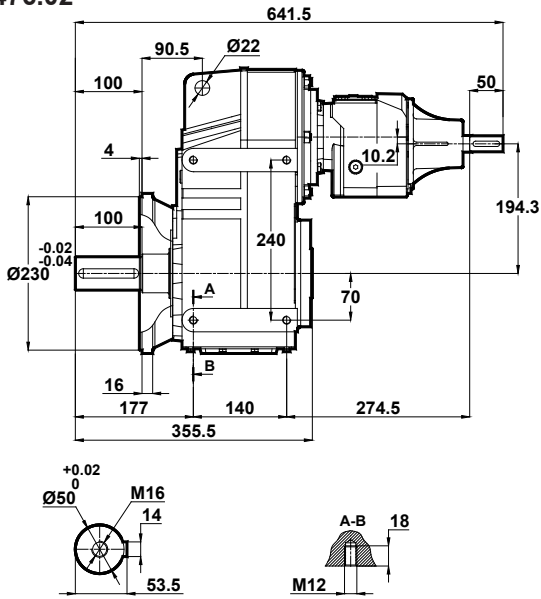

Opsiyonel Flanş Ölçüleri  
Optional Flange Dimensions  
Auswählbare Flanschabmessungen

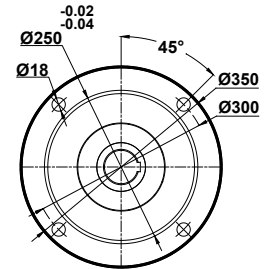

Diğer opsiyonel flanş ölçüleri için sayfa 326'ya bakınız.  
Please see on page 326 for other optional flange dimensions  
Siehe Seite 326 für andere auswählbare Flanschabmessungen

DT475.03  
DT476.03

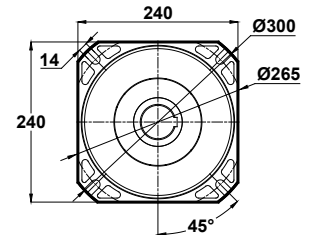
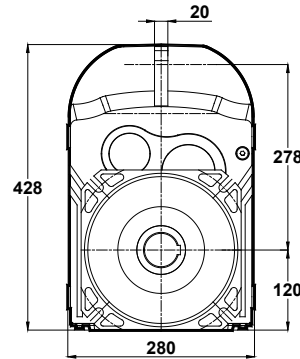
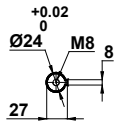
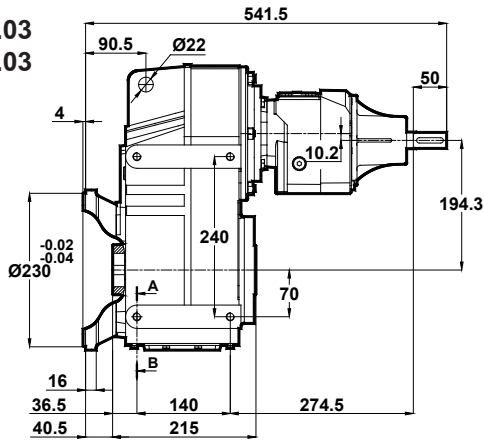

Opsiyonel Flanş Ölçüleri  
Optional Flange Dimensions  
Auswählbare Flanschabmessungen

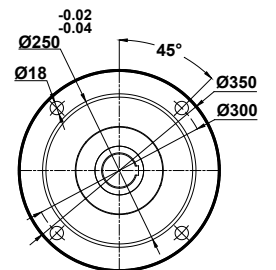

Diğer opsiyonel flanş ölçüleri için sayfa 326'ya bakınız.  
Please see on page 326 for other optional flange dimensions  
Siehe Seite 326 für andere auswählbare Flanschabmessungen

-Mil ucu çektirme deliği DIN 332 sayfa 2 / Tapped center hole according to DIN 332, sheet 2 / Zentrierung mit Gewinde nach DIN 332, Blatt 2

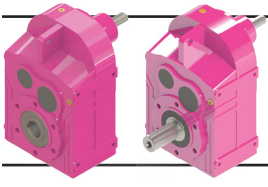

# Ölçü Sayfaları

## Dimension Pages

### Abmessungsseiten

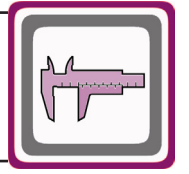

DT572.00  
DT573.00

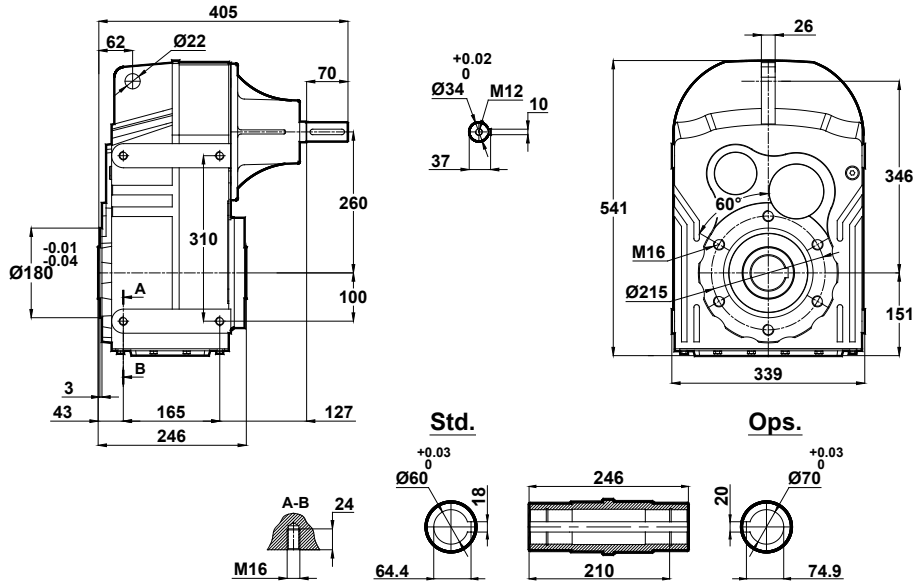

DT572.01  
DT573.01

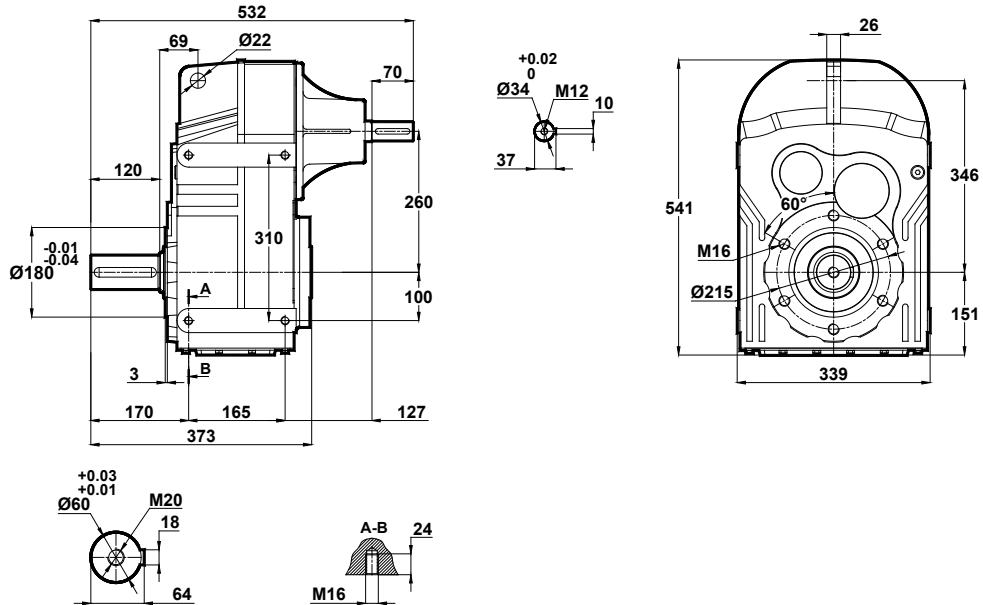

-Mil ucu çekirme deliği DIN 332 sayfa 2 / Tapped center hole according to DIN 332, sheet 2 / Zentrierung mit Gewinde nach DIN 332, Blatt 2

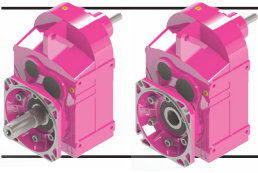

# Ölçü Sayfaları Dimension Pages Abmessungenseiten

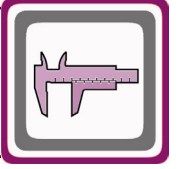

DT572.02  
DT573.02

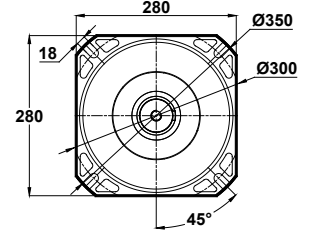
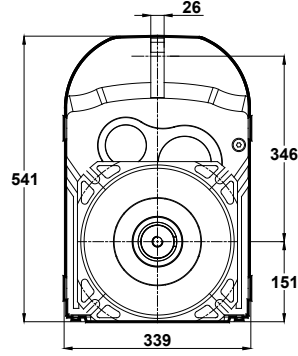
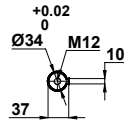
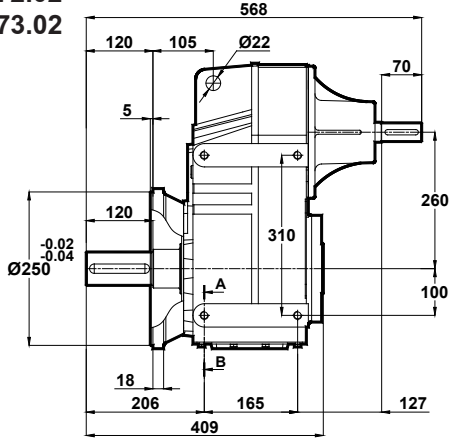

Opsiyonel Flanş Ölçüleri  
Optional Flange Dimensions  
Auswählbare Flanschabmessungen

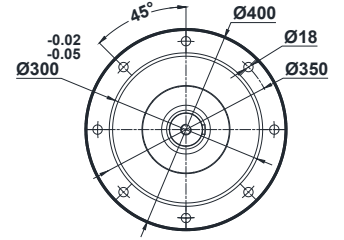

Diğer opsiyonel flanş ölçüleri için sayfa 326'ya bakınız.  
Please see on page 326 for other optional flange dimensions  
Siehe Seite 326 für andere auswählbare Flanschabmessungen

DT572.03  
DT573.03

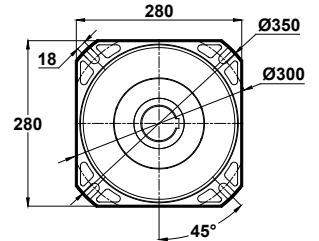
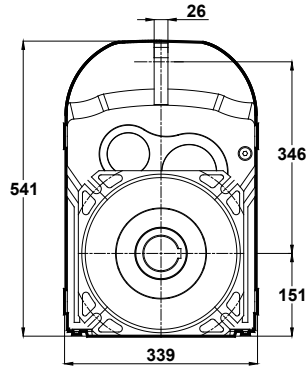
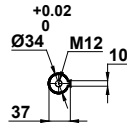
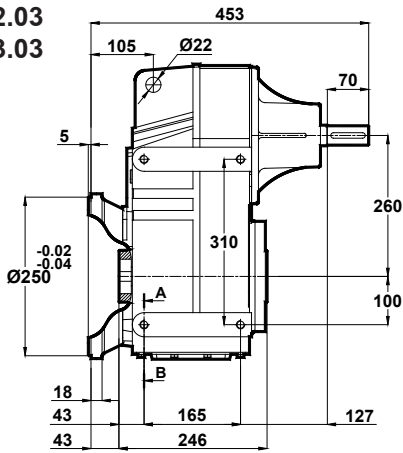

Opsiyonel Flanş Ölçüleri  
Optional Flange Dimensions  
Auswählbare Flanschabmessungen

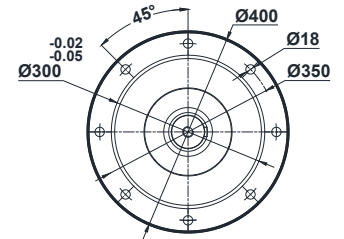
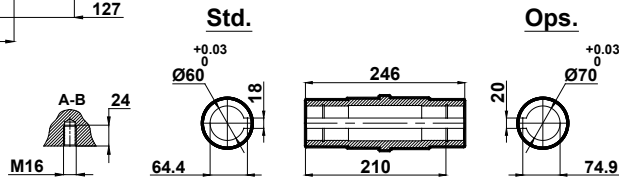

Diğer opsiyonel flanş ölçüleri için sayfa 326'ya bakınız.  
Please see on page 326 for other optional flange dimensions  
Siehe Seite 326 für andere auswählbare Flanschabmessungen

-Mil ucu çektirme deliği DIN 332 sayfa 2 / Tapped center hole according to DIN 332, sheet 2 / Zentrierung mit Gewinde nach DIN 332, Blatt 2

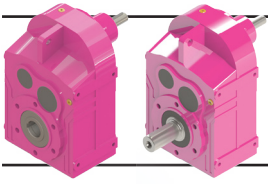

# Ölçü Sayfaları

## Dimension Pages

### Abmessungsseiten

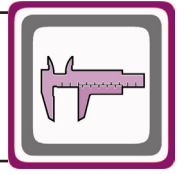

DT574.00

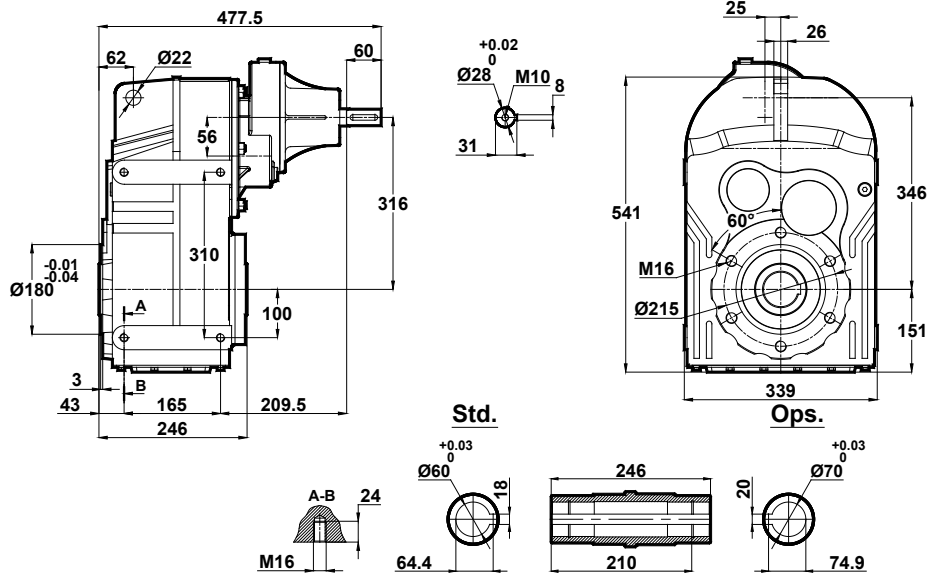

DT574.01

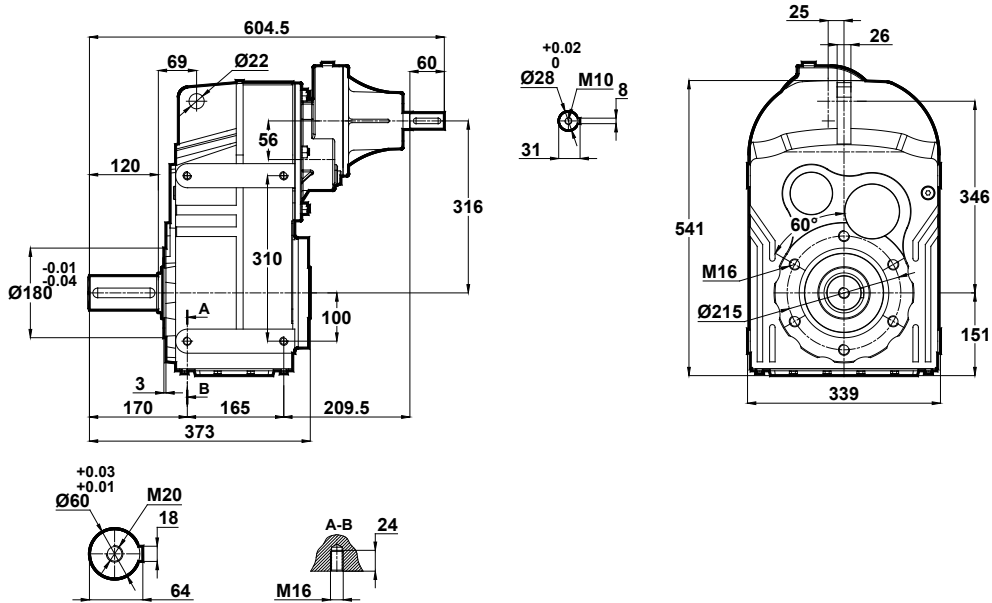

-Mil ucu çekirme deliği DIN 332 sayfa 2 / Tapped center hole according to DIN 332, sheet 2 / Zentrierung mit Gewinde nach DIN 332, Blatt 2

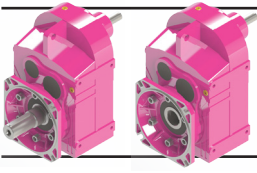

# Ölçü Sayfaları Dimension Pages Abmessungenseiten

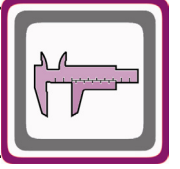

## DT574.02

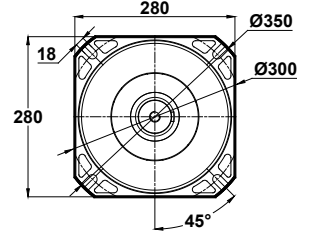
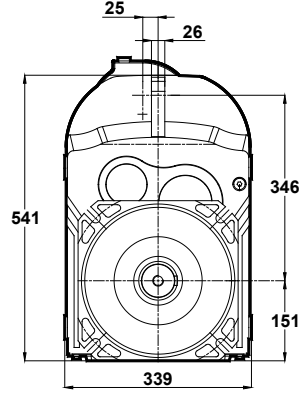
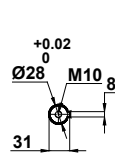
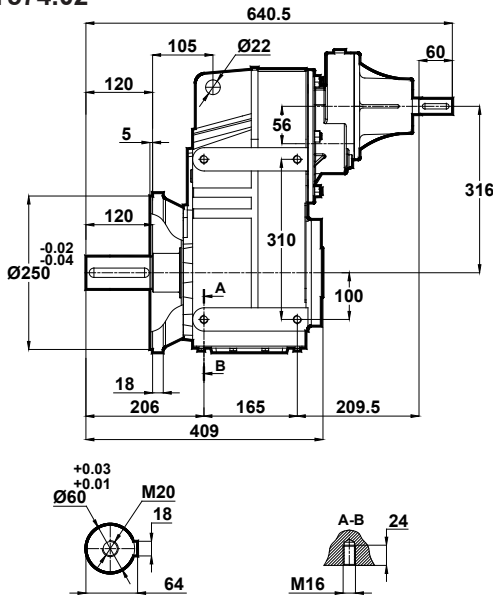

Opsiyonel Flanş Ölçüleri  
Optional Flange Dimensions  
Auswählbare Flanschabmessungen

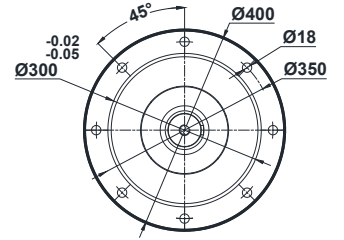

Diğer opsiyonel flanş ölçüleri için sayfa 326'ya bakınız.  
Please see on page 326 for other optional flange dimensions  
Siehe Seite 326 für andere auswählbare Flanschabmessungen

## DT574.03

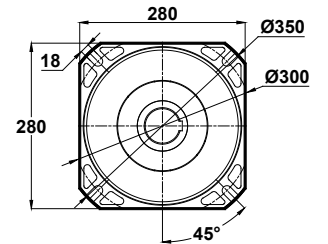
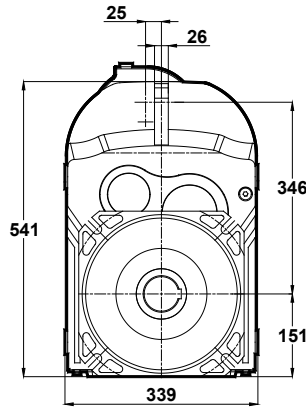
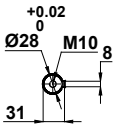
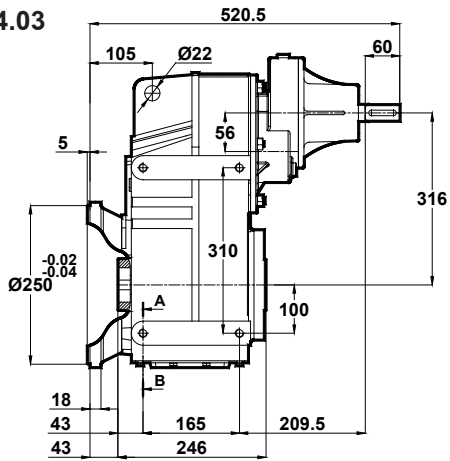

Opsiyonel Flanş Ölçüleri  
Optional Flange Dimensions  
Auswählbare Flanschabmessungen

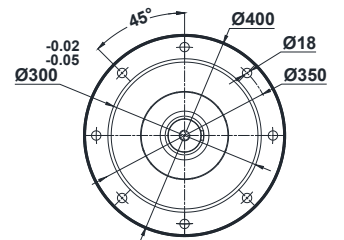
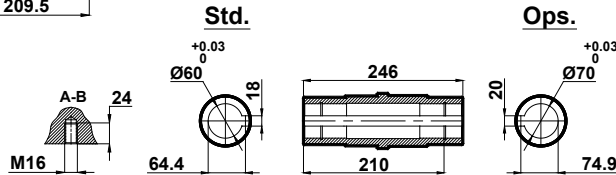

Diğer opsiyonel flanş ölçüleri için sayfa 326'ya bakınız.  
Please see on page 326 for other optional flange dimensions  
Siehe Seite 326 für andere auswählbare Flanschabmessungen

-Mil ucu çektirme deliği DIN 332 sayfa 2 / Tapped center hole according to DIN 332, sheet 2 / Zentrierung mit Gewinde nach DIN 332, Blatt 2



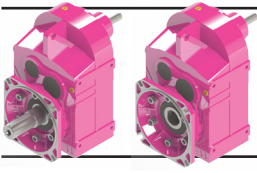

# Ölçü Sayfaları Dimension Pages Abmessungenseiten

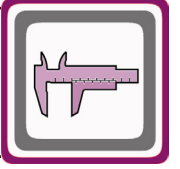

DT575.02  
DT576.02

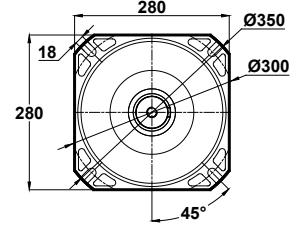
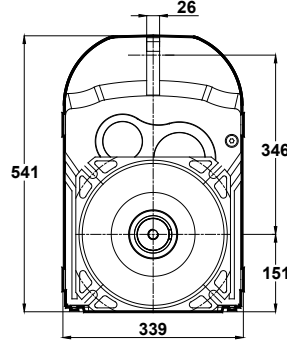
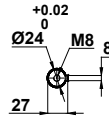
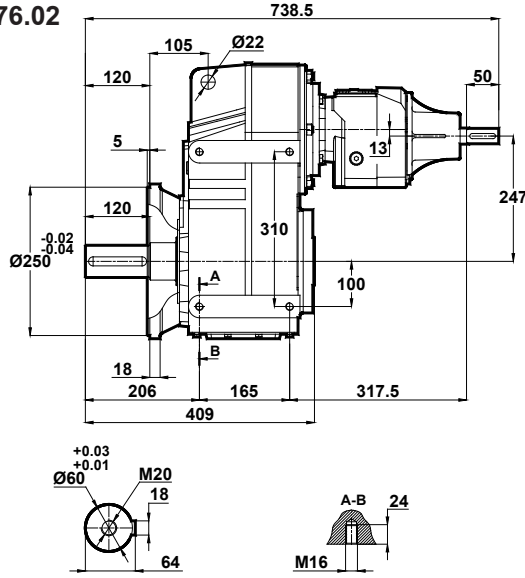

Opsiyonel Flanş Ölçüleri  
Optional Flange Dimensions  
Auswählbare Flanschabmessungen

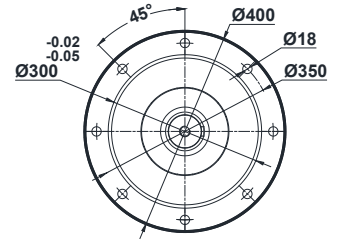

Diğer opsiyonel flanş ölçüleri için sayfa 326'ya bakınız.  
Please see on page 326 for other optional flange dimensions  
Siehe Seite 326 für andere auswählbare Flanschabmessungen

DT575.03  
DT576.03

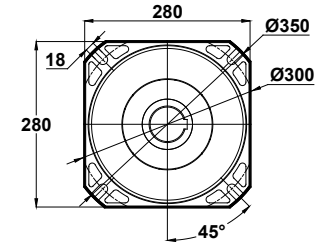
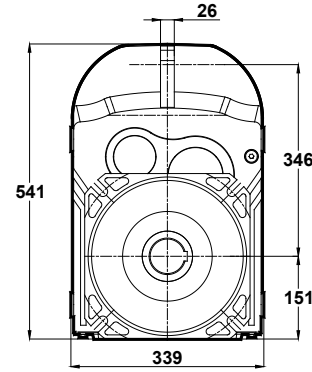
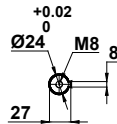
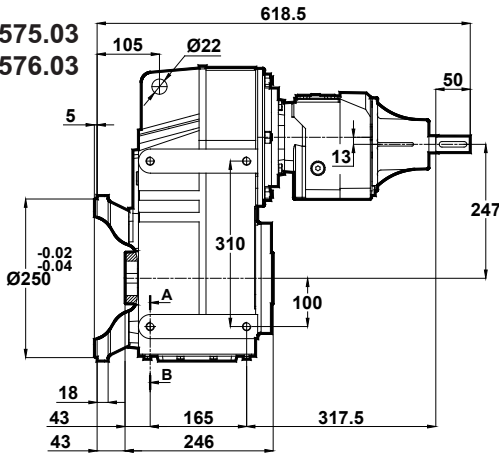

Std.

Ops.

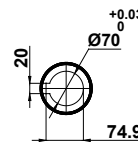
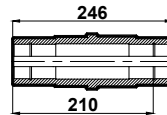
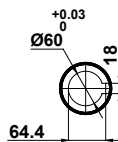
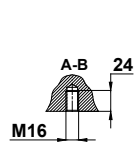

Opsiyonel Flanş Ölçüleri  
Optional Flange Dimensions  
Auswählbare Flanschabmessungen

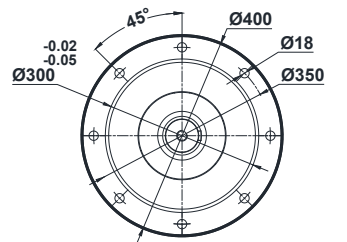

Diğer opsiyonel flanş ölçüleri için sayfa 326'ya bakınız.  
Please see on page 326 for other optional flange dimensions  
Siehe Seite 326 für andere auswählbare Flanschabmessungen

-Mil ucu çektirme deliği DIN 332 sayfa 2 / Tapped center hole according to DIN 332, sheet 2 / Zentrierung mit Gewinde nach DIN 332, Blatt 2

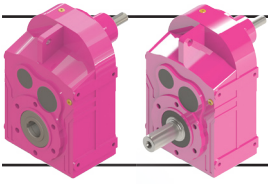

# Ölçü Sayfaları

## Dimension Pages

### Abmessungsseiten

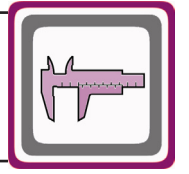

DT672.00  
DT673.00

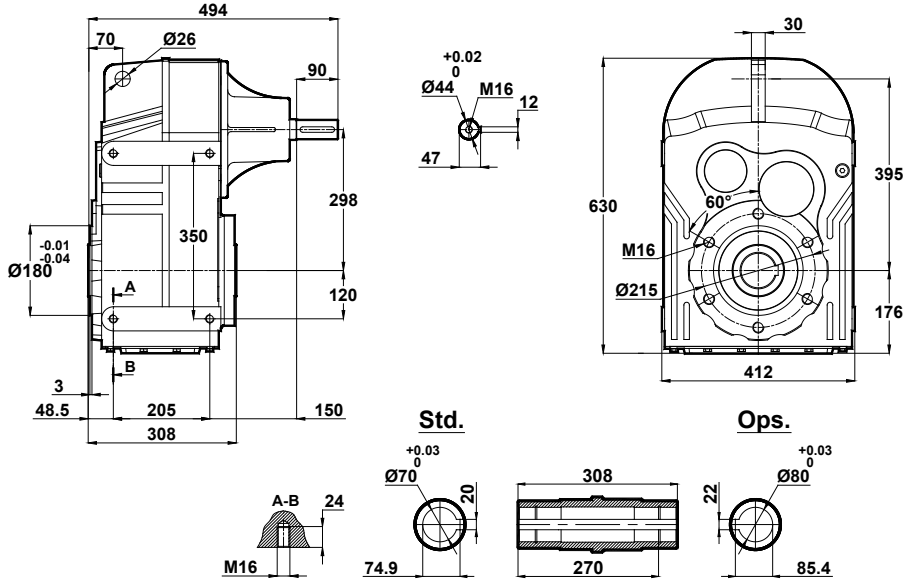

DT672.01  
DT673.01

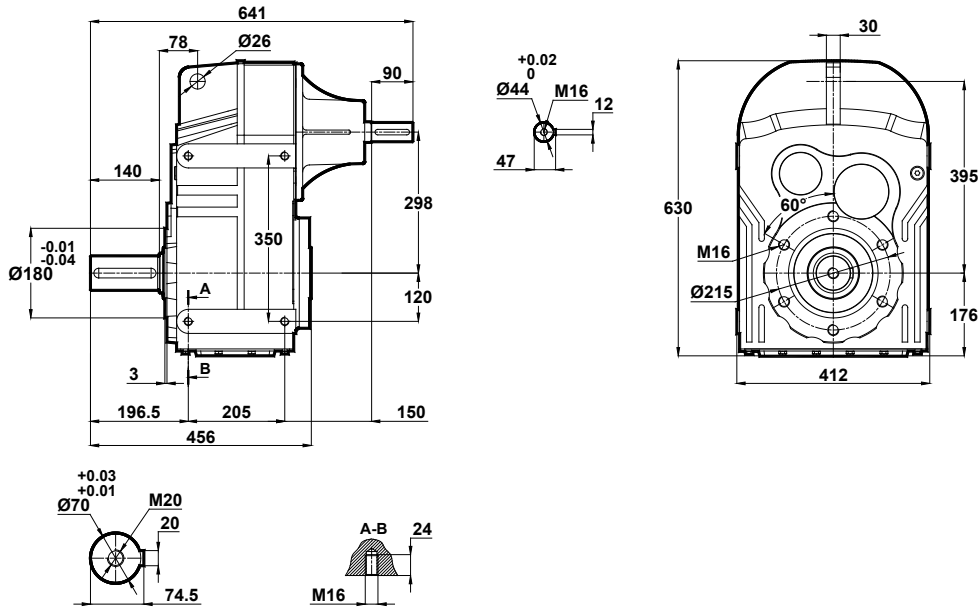

-Mil ucu çekirme deliği DIN 332 sayfa 2 / Tapped center hole according to DIN 332, sheet 2 / Zentrierung mit Gewinde nach DIN 332, Blatt 2





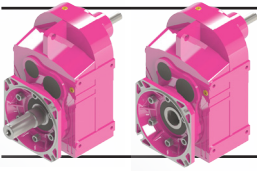

# Ölçü Sayfaları Dimension Pages Abmessungsseiten

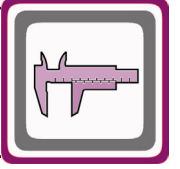

## DT674.02

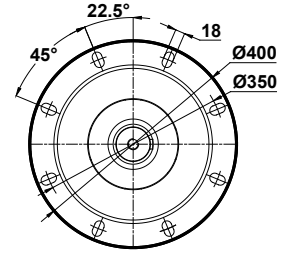
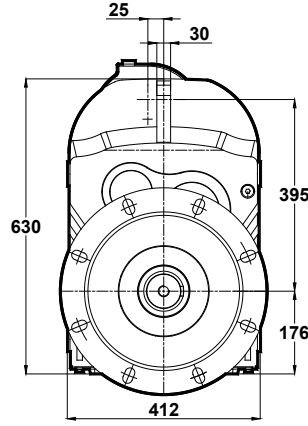
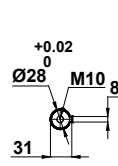
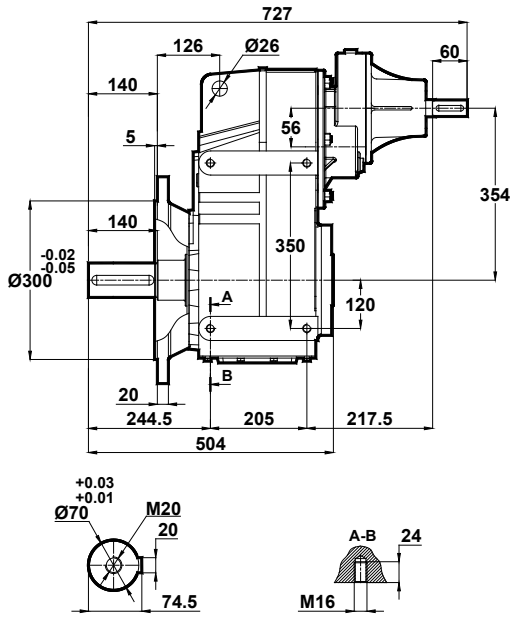

Opsiyonel Flanş Ölçüleri  
Optional Flange Dimensions  
Auswählbare Flanschabmessungen

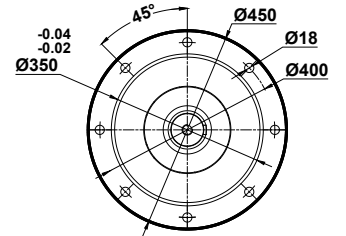

Diğer opsiyonel flanş ölçüleri için sayfa 326'ya bakınız.  
Please see on page 326 for other optional flange dimensions  
Siehe Siete 326 für andere auswählbare Flanschabmessungen

## DT674.03

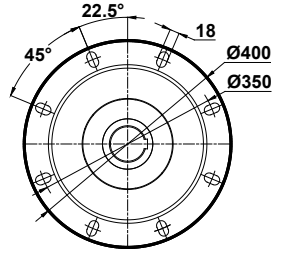
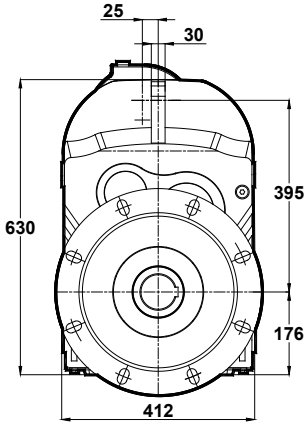
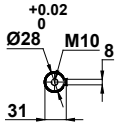
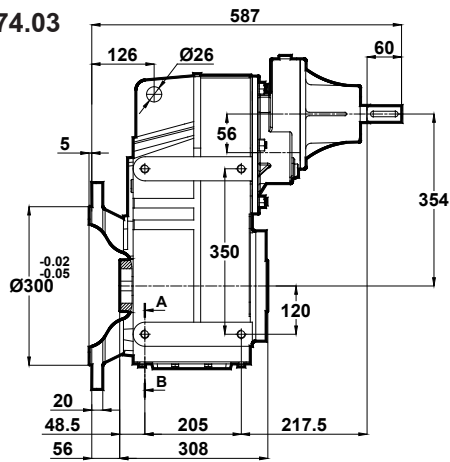

Opsiyonel Flanş Ölçüleri  
Optional Flange Dimensions  
Auswählbare Flanschabmessungen

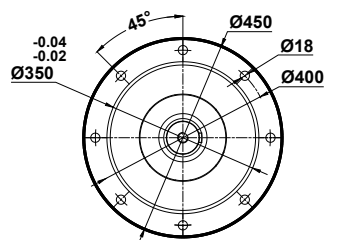

Diğer opsiyonel flanş ölçüleri için sayfa 326'ya bakınız.  
Please see on page 326 for other optional flange dimensions  
Siehe Siete 326 für andere auswählbare Flanschabmessungen

-Mil ucu çektirme deliği DIN 332 sayfa 2 / Tapped center hole according to DIN 332, sheet 2 / Zentrierung mit Gewinde nach DIN 332, Blatt 2

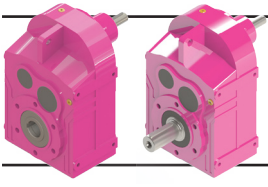

# Ölçü Sayfaları

## Dimension Pages

## Abmessungsseiten

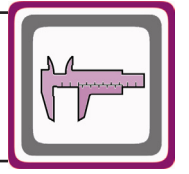

DT675.00  
DT676.00

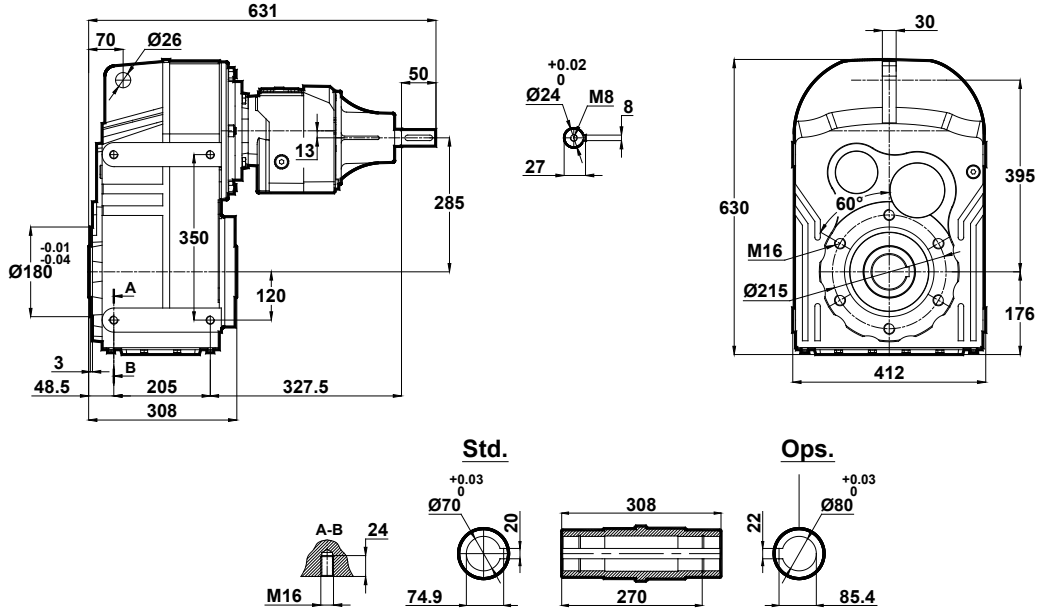

DT675.01  
DT676.01

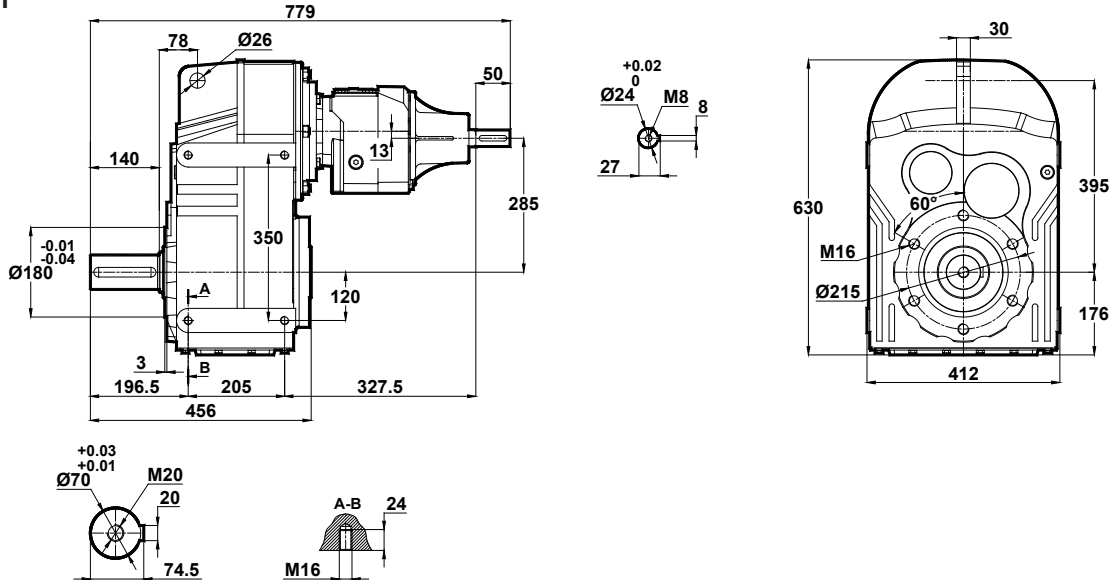

-Mil ucu çekirme deliği DIN 332 sayfa 2 / Tapped center hole according to DIN 332, sheet 2 / Zentrierung mit Gewinde nach DIN 332, Blatt 2

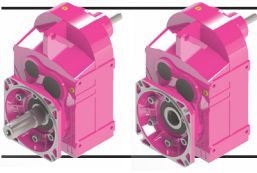

# Ölçü Sayfaları Dimension Pages Abmessungenseiten

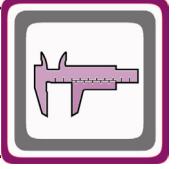

DT675.02  
DT676.02

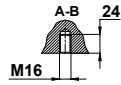
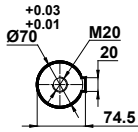
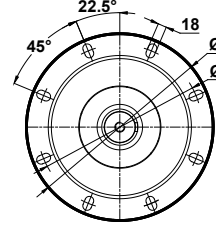
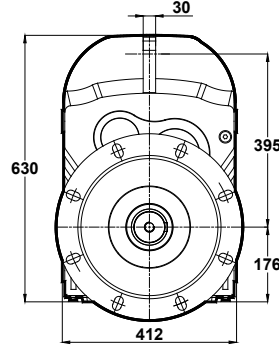
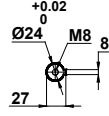
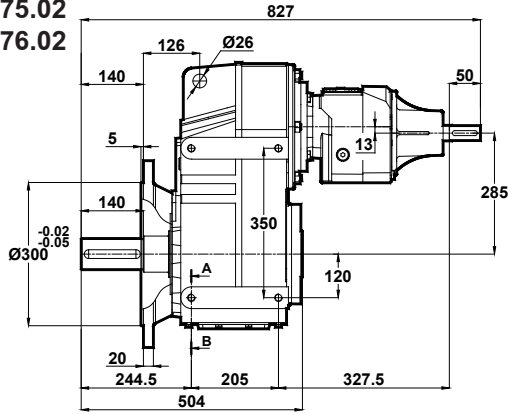

Opsiyonel Flanş Ölçüleri  
Optional Flange Dimensions  
Auswählbare Flanschabmessungen

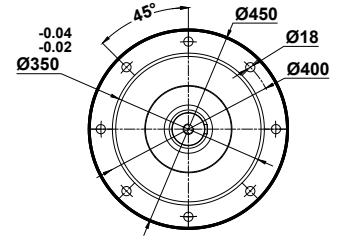

Diğer opsiyonel flanş ölçüleri için sayfa 326'ya bakınız.  
Please see on page 326 for other optional flange dimensions  
Siehe Seite 326 für andere auswählbare Flanschabmessungen

DT675.03  
DT676.03

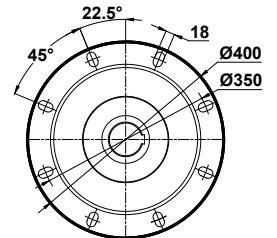
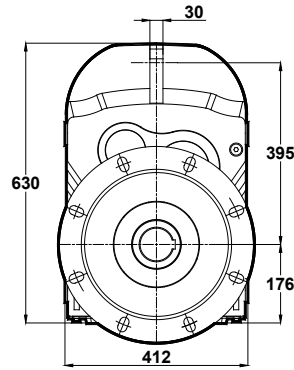
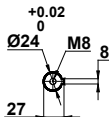
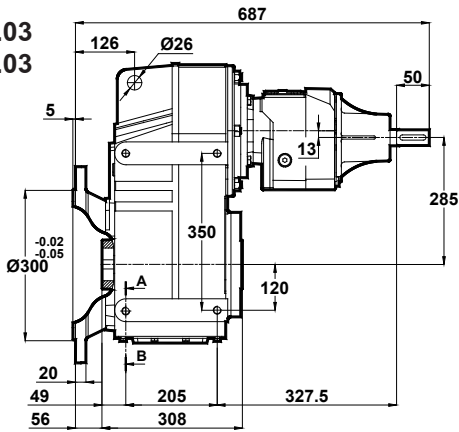

Std.

Ops.

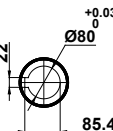
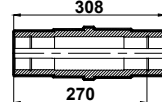
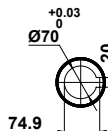
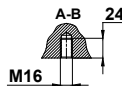

Opsiyonel Flanş Ölçüleri  
Optional Flange Dimensions  
Auswählbare Flanschabmessungen

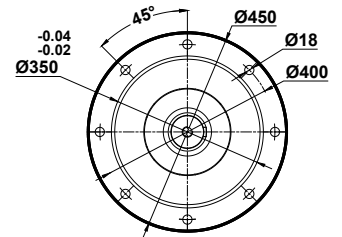

Diğer opsiyonel flanş ölçüleri için sayfa 326'ya bakınız.  
Please see on page 326 for other optional flange dimensions  
Siehe Seite 326 für andere auswählbare Flanschabmessungen

-Mil ucu çektirme deliği DIN 332 sayfa 2 / Tapped center hole according to DIN 332, sheet 2 / Zentrierung mit Gewinde nach DIN 332, Blatt 2

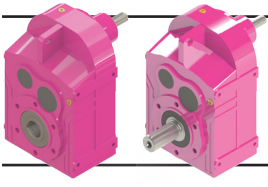

# Ölçü Sayfaları

## Dimension Pages

### Abmessungsseiten

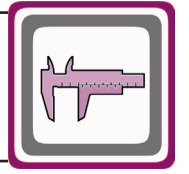

DT772.00  
DT773.00

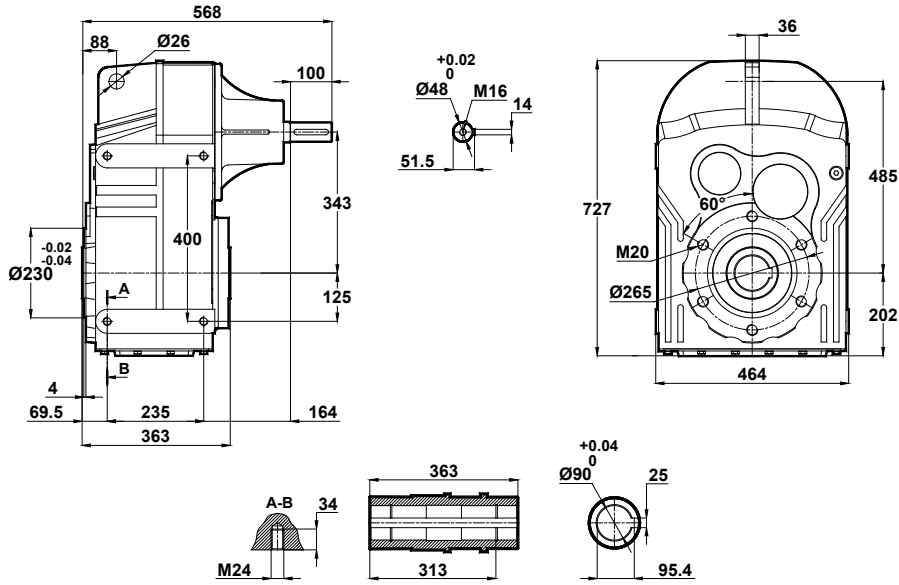

DT772.01  
DT773.01

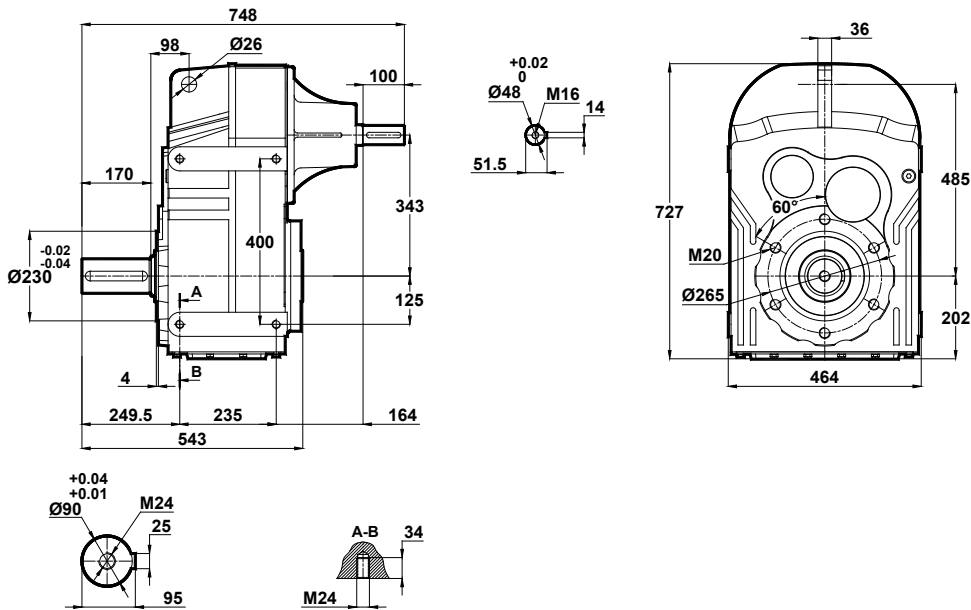

-Mil ucu çekirme deliği DIN 332 sayfa 2 / Tapped center hole according to DIN 332, sheet 2 / Zentrierung mit Gewinde nach DIN 332, Blatt 2

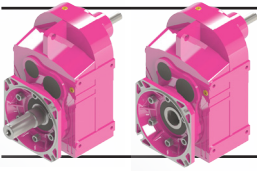

# Ölçü Sayfaları Dimension Pages Abmessungenseiten

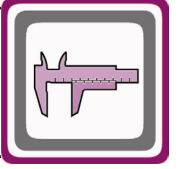

DT772.02  
DT773.02

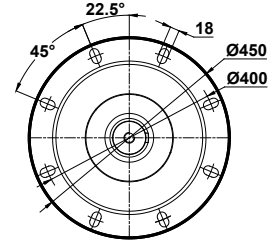
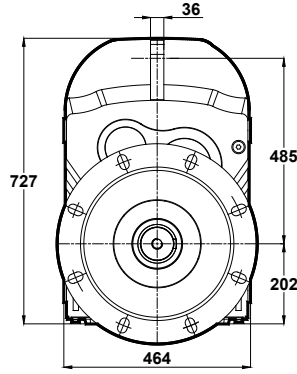
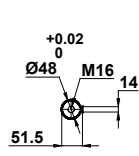
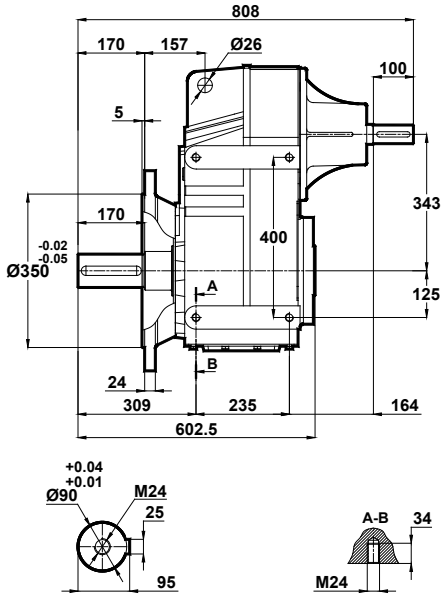

Opsiyonel flanş ölçüleri için sayfa 326'ya bakınız.  
Please see on page 326 for optional flange dimensions  
Siehe Siete 326 für auswählbare Flanschabmessungen

DT772.03  
DT773.03

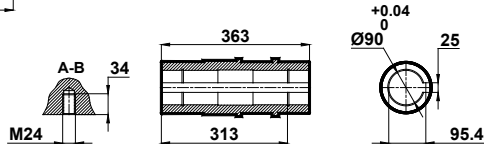
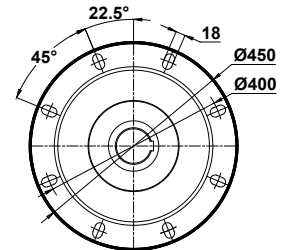
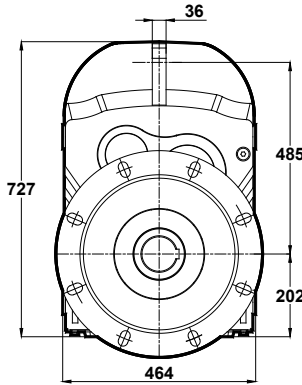
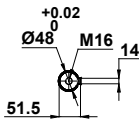
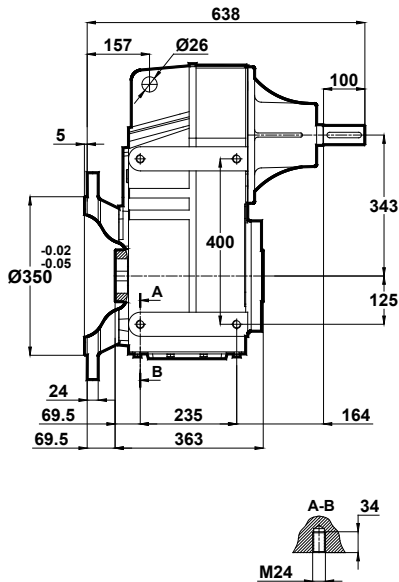

Opsiyonel flanş ölçüleri için sayfa 326'ya bakınız.  
Please see on page 326 for optional flange dimensions  
Siehe Siete 326 für auswählbare Flanschabmessungen

-Mil ucu çektirme deliği DIN 332 sayfa 2 / Tapped center hole according to DIN 332, sheet 2 / Zentrierung mit Gewinde nach DIN 332, Blatt 2

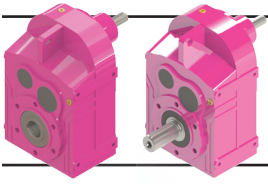

# Ölçü Sayfaları

## Dimension Pages

### Abmessungsseiten

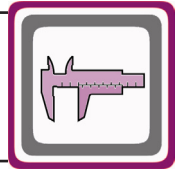

DT774.00

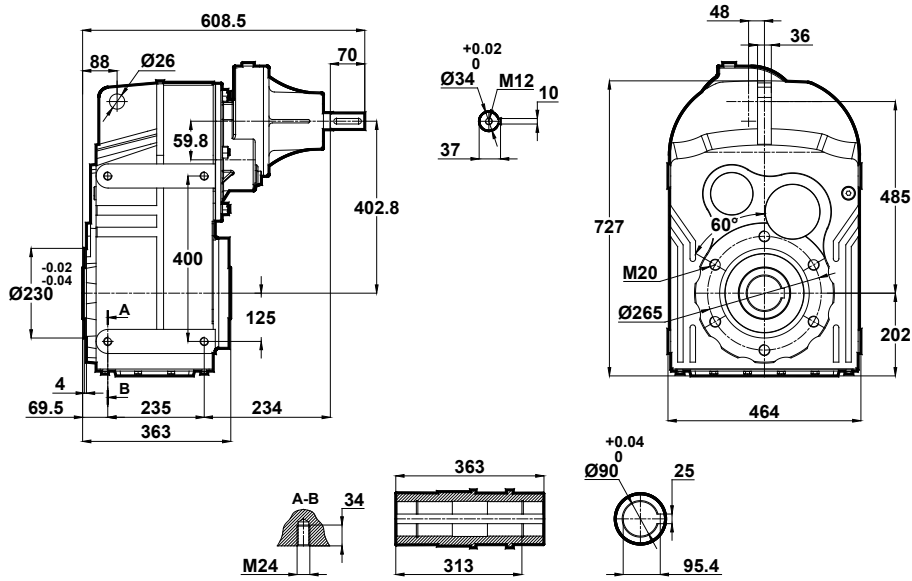

DT774.01

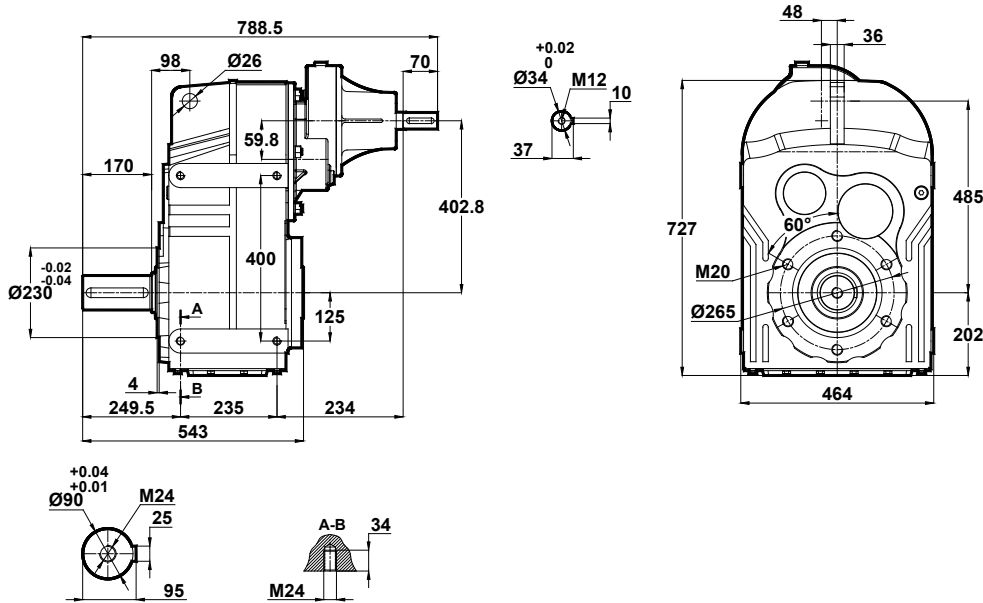

-Mil ucu çekirme deliği DIN 332 sayfa 2 / Tapped center hole according to DIN 332, sheet 2 / Zentrierung mit Gewinde nach DIN 332, Blatt 2

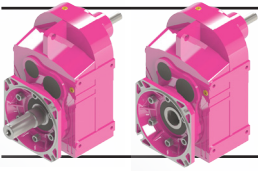

# Ölçü Sayfaları Dimension Pages Abmessungenseiten

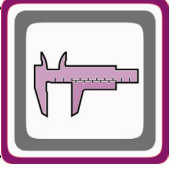

DT774.02

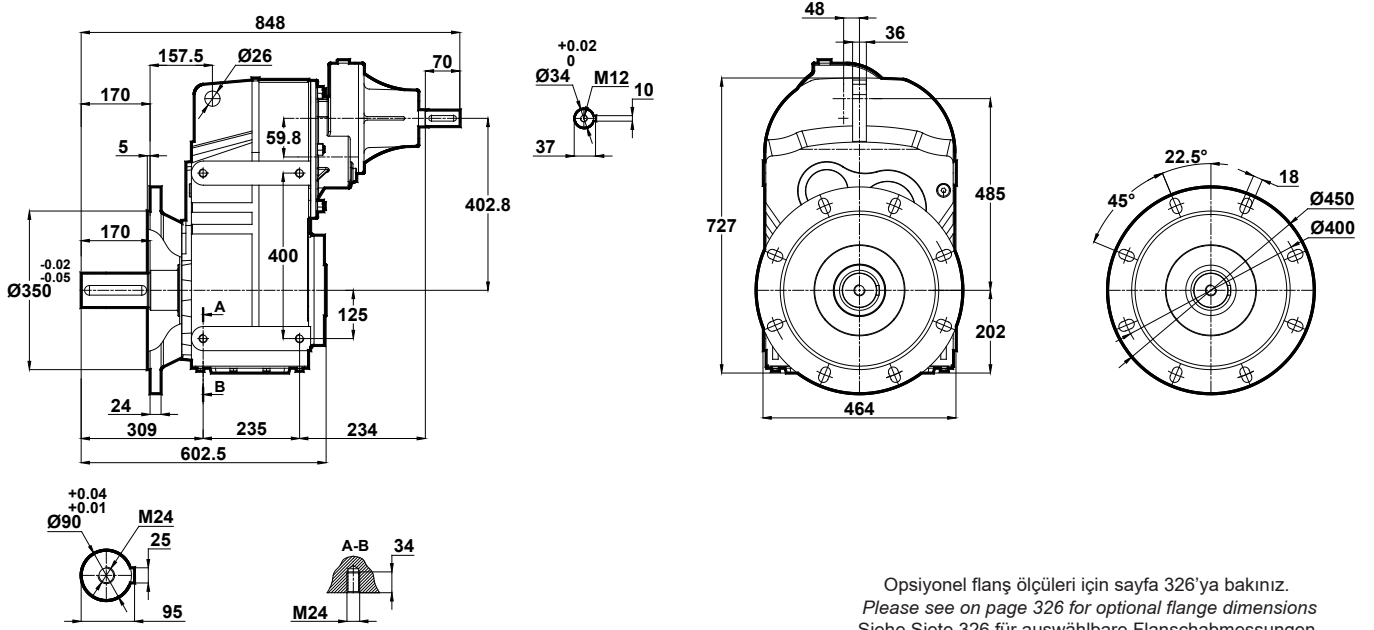

Opsiyonel flanş ölçüleri için sayfa 326'ya bakınız.  
Please see on page 326 for optional flange dimensions  
Siehe Seite 326 für auswählbare Flanschabmessungen

DT774.03

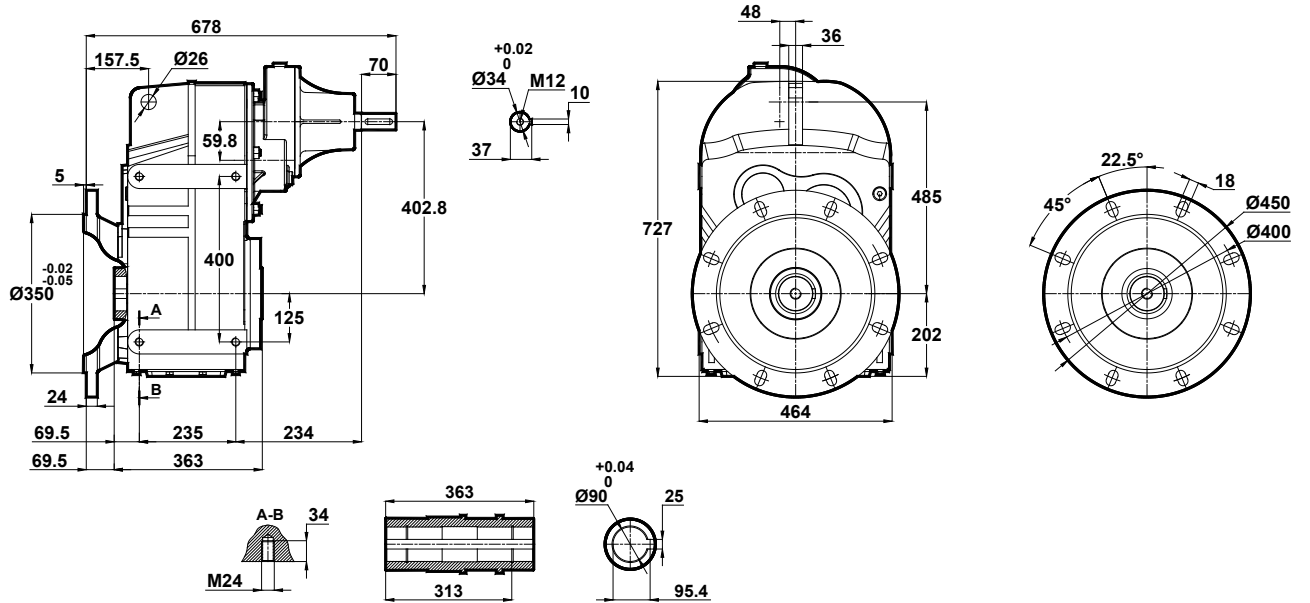

Opsiyonel flanş ölçüleri için sayfa 326'ya bakınız.  
Please see on page 326 for optional flange dimensions  
Siehe Seite 326 für auswählbare Flanschabmessungen

-Mil ucu çektirme deliği DIN 332 sayfa 2 / Tapped center hole according to DIN 332, sheet 2 / Zentrierung mit Gewinde nach DIN 332, Blatt 2

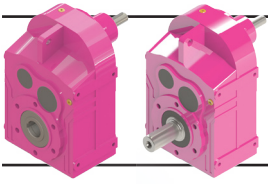

# Ölçü Sayfaları

## Dimension Pages

## Abmessungsseiten

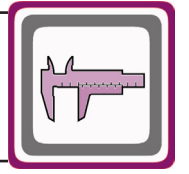

DT775.00  
DT776.00

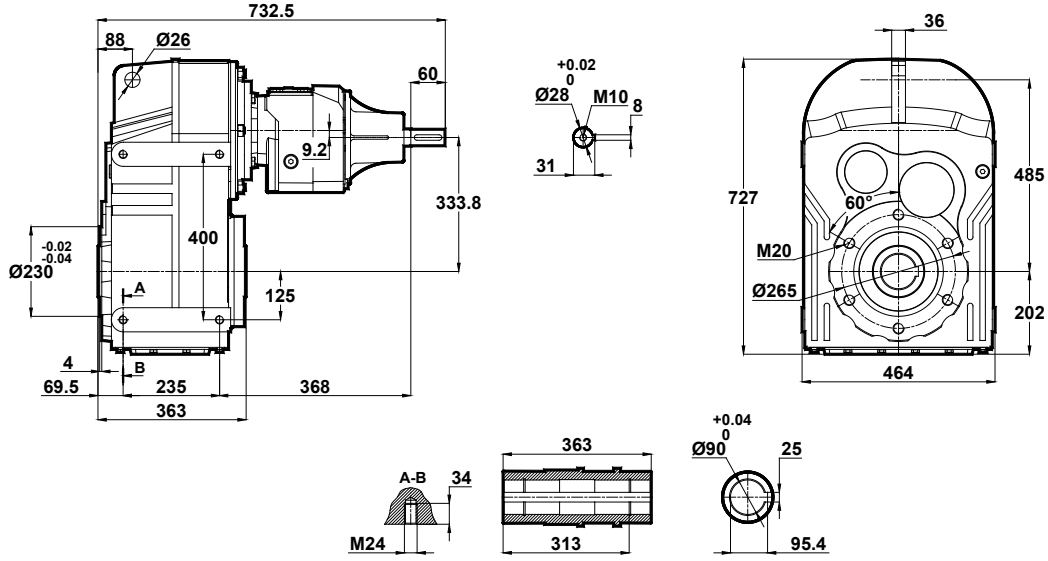

DT775.01  
DT776.01

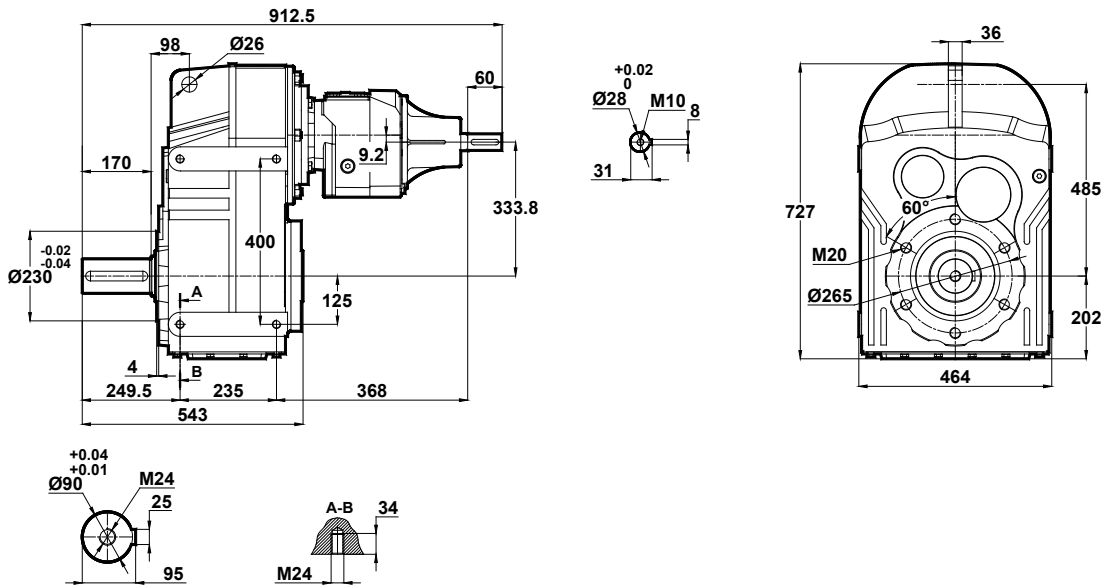

-Mil ucu çekirme deliği DIN 332 sayfa 2 / Tapped center hole according to DIN 332, sheet 2 / Zentrierung mit Gewinde nach DIN 332, Blatt 2

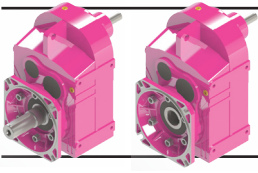

# Ölçü Sayfaları Dimension Pages Abmessungenseiten

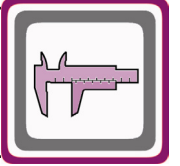

DT775.02  
DT776.02

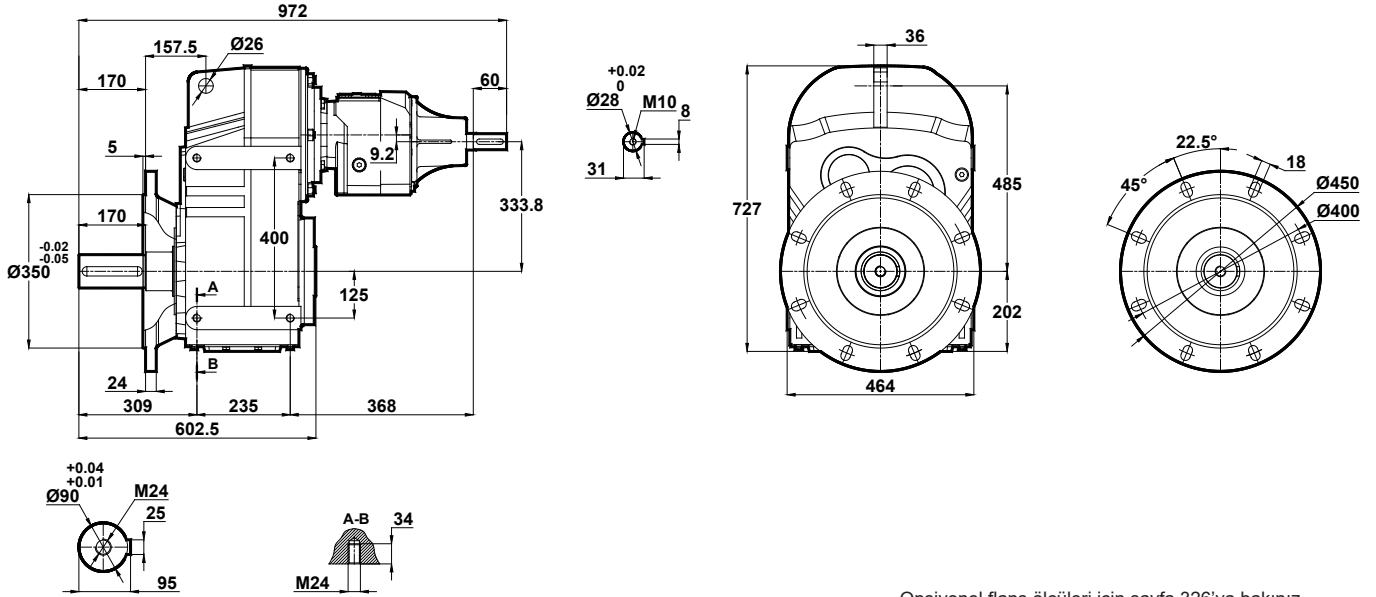

Opsiyonel flanş ölçüleri için sayfa 326'ya bakınız.  
Please see on page 326 for optional flange dimensions  
Siehe Seite 326 für auswählbare Flanschabmessungen

DT775.03  
DT776.03

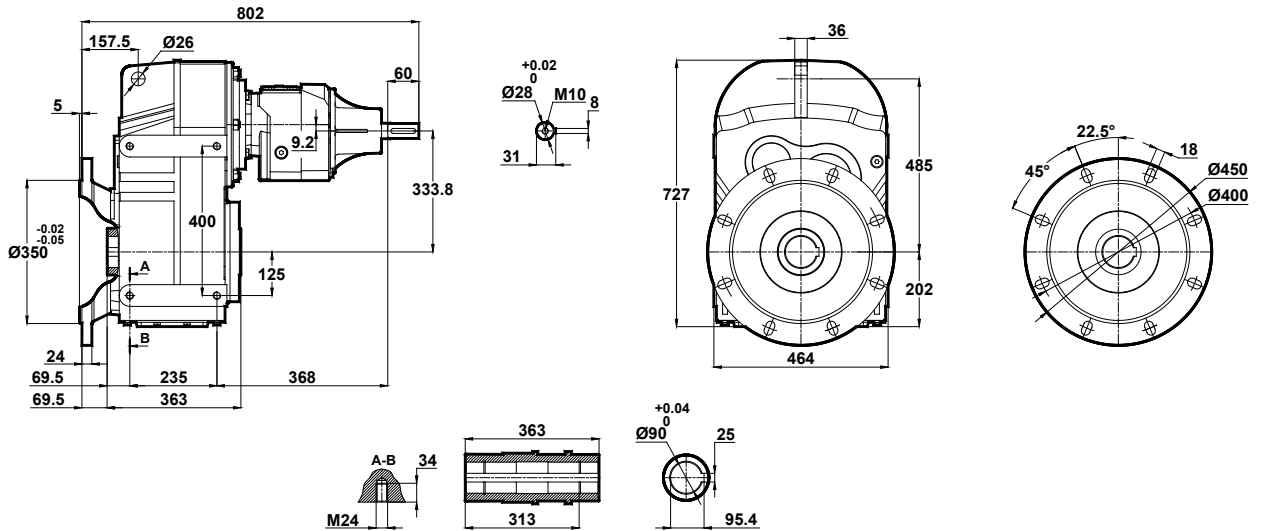

Opsiyonel flanş ölçüleri için sayfa 326'ya bakınız.  
Please see on page 326 for optional flange dimensions  
Siehe Seite 326 für auswählbare Flanschabmessungen

-Mil ucu çektirme deliği DIN 332 sayfa 2 / Tapped center hole according to DIN 332, sheet 2 / Zentrierung mit Gewinde nach DIN 332, Blatt 2

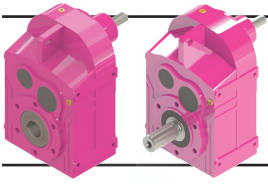

# Ölçü Sayfaları

## Dimension Pages

## Abmessungsseiten

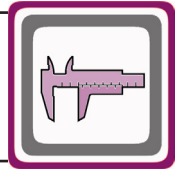

DT872.00  
DT873.00

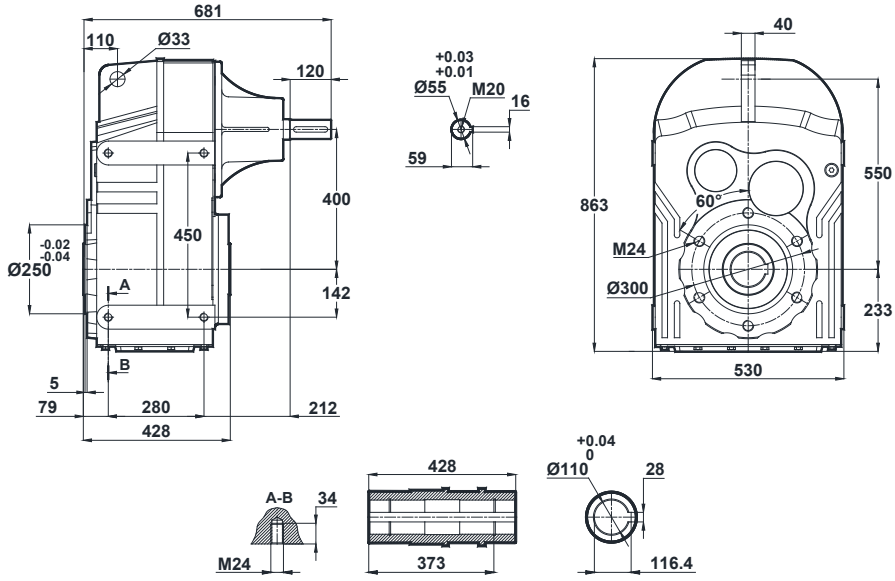

DT872.01  
DT873.01

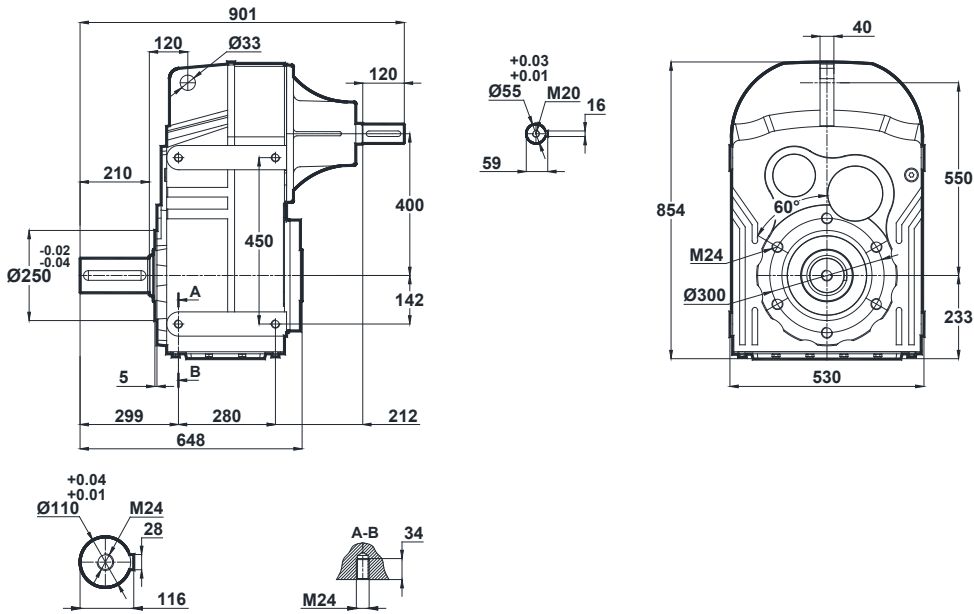

-Mil ucu çekirme deliği DIN 332 sayfa 2 / Tapped center hole according to DIN 332, sheet 2 / Zentrierung mit Gewinde nach DIN 332, Blatt 2



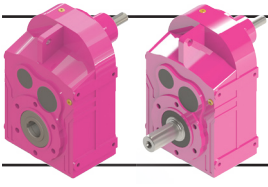

# Ölçü Sayfaları

## Dimension Pages

## Abmessungsseiten

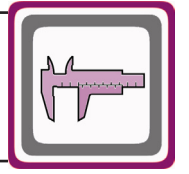

DT874.00

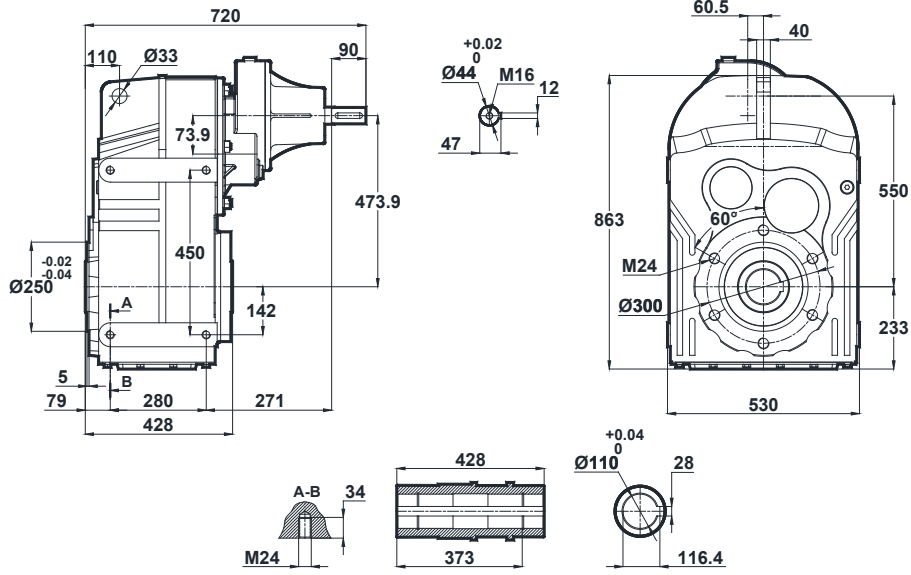

DT874.01

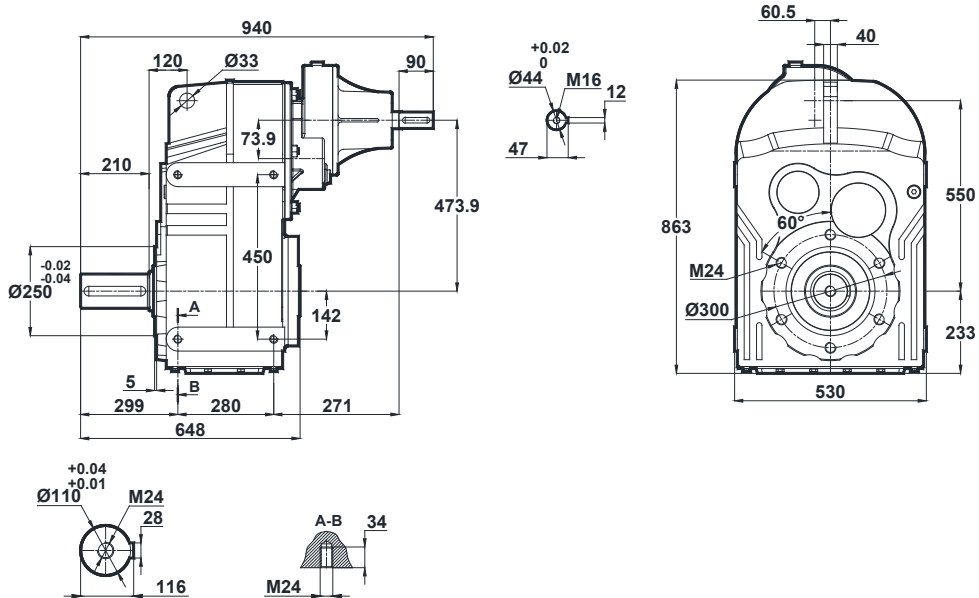

-Mil ucu çekirme deliği DIN 332 sayfa 2 / Tapped center hole according to DIN 332, sheet 2 / Zentrierung mit Gewinde nach DIN 332, Blatt 2

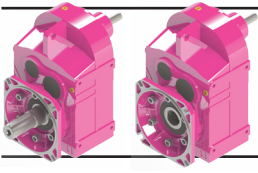

# Ölçü Sayfaları

## Dimension Pages

### Abmessungsseiten

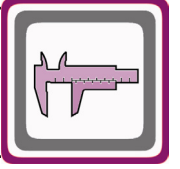

DT874.02

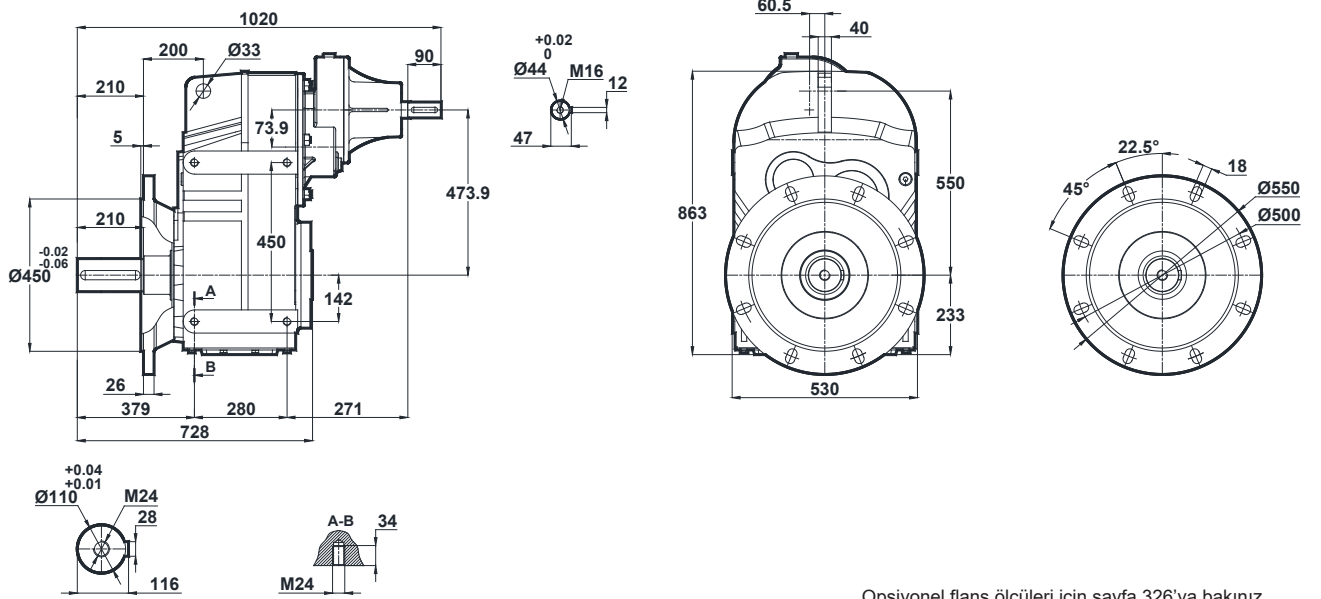

Opsiyonel flanş ölçüleri için sayfa 326'ya bakınız.  
Please see on page 326 for optional flange dimensions  
Siehe Seite 326 für auswählbare Flanschabmessungen

DT874.03

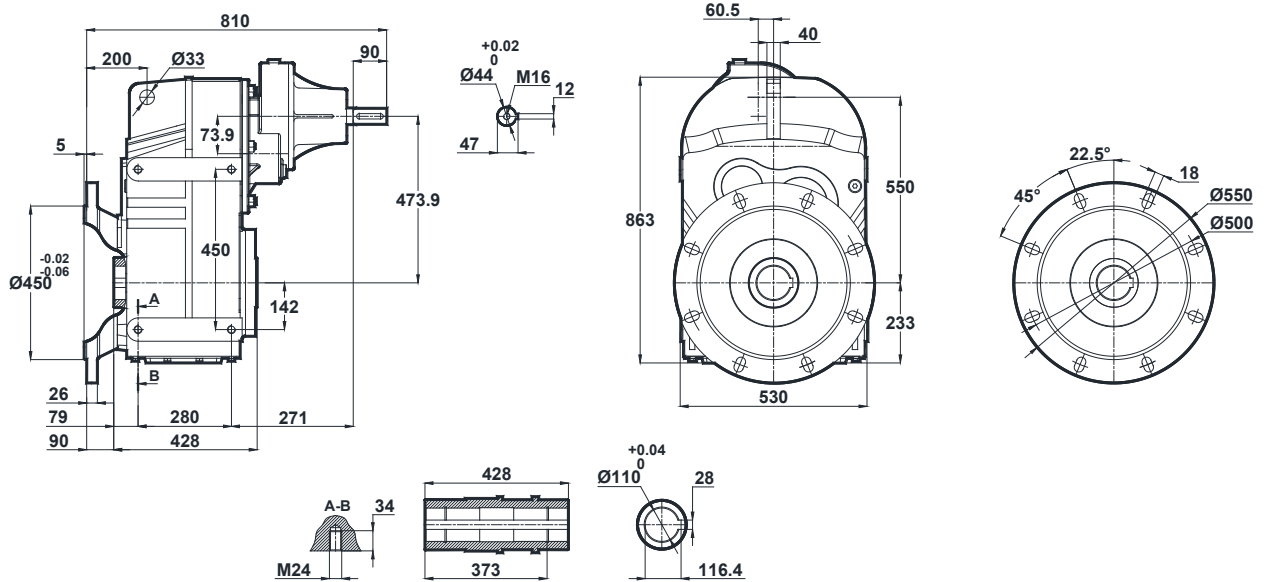

Opsiyonel flanş ölçüleri için sayfa 326'ya bakınız.  
Please see on page 326 for optional flange dimensions  
Siehe Seite 326 für auswählbare Flanschabmessungen

-Mil ucu çektirme deliği DIN 332 sayfa 2 / Tapped center hole according to DIN 332, sheet 2 / Zentrierung mit Gewinde nach DIN 332, Blatt 2

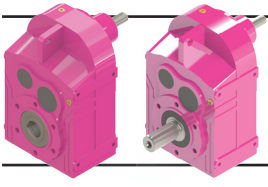

# Ölçü Sayfaları

## Dimension Pages

### Abmessungsseiten

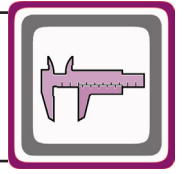

DT875.00  
DT876.00

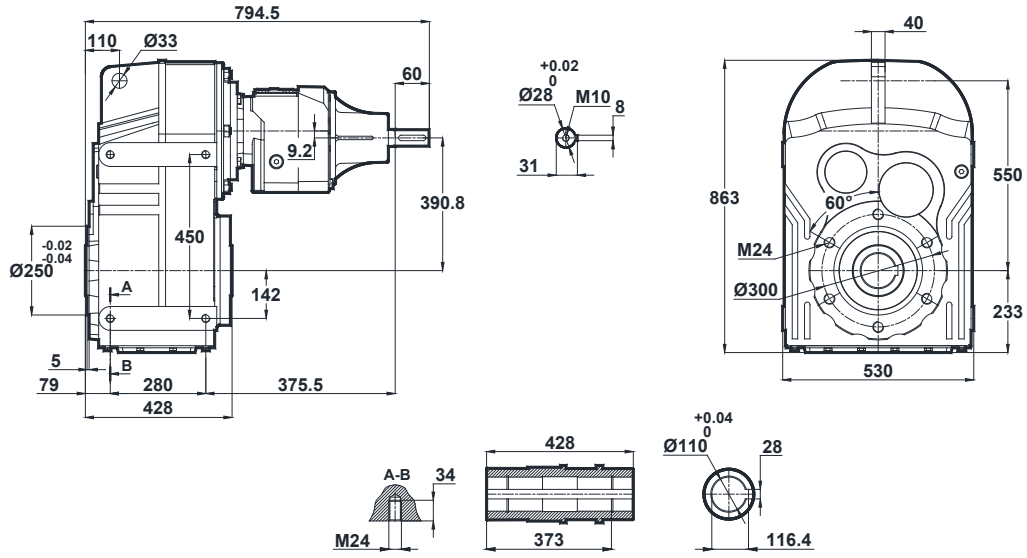

DT875.01  
DT876.01

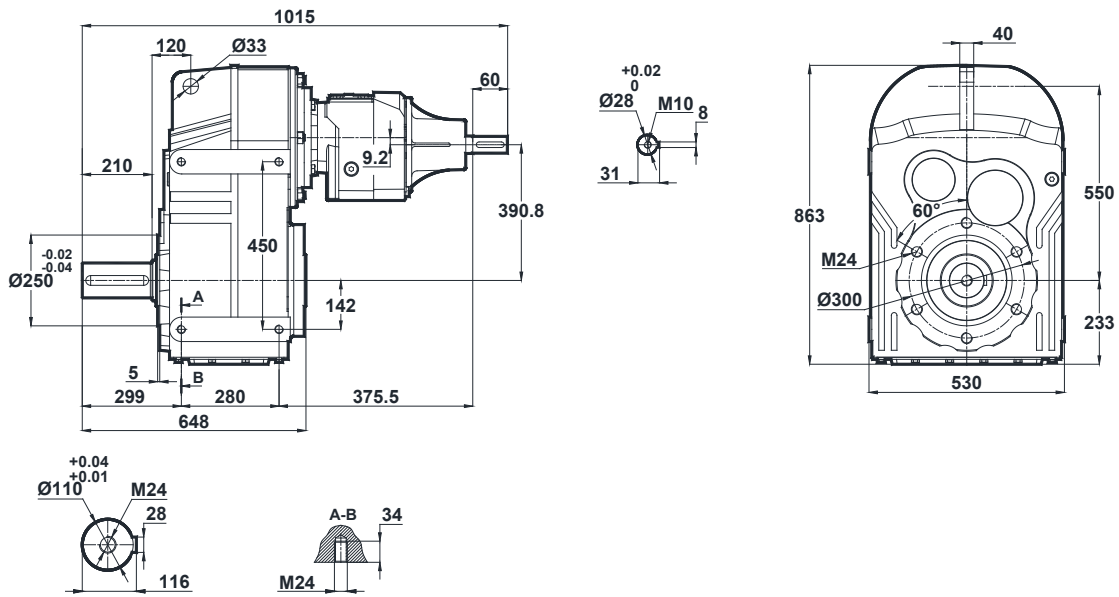

-Mil ucu çekirme deliği DIN 332 sayfa 2 / Tapped center hole according to DIN 332, sheet 2 / Zentrierung mit Gewinde nach DIN 332, Blatt 2

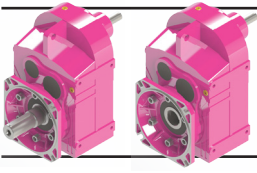

# Ölçü Sayfaları

## Dimension Pages

### Abmessungenseiten

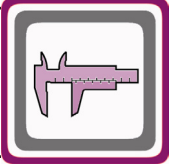

DT875.02  
DT876.02

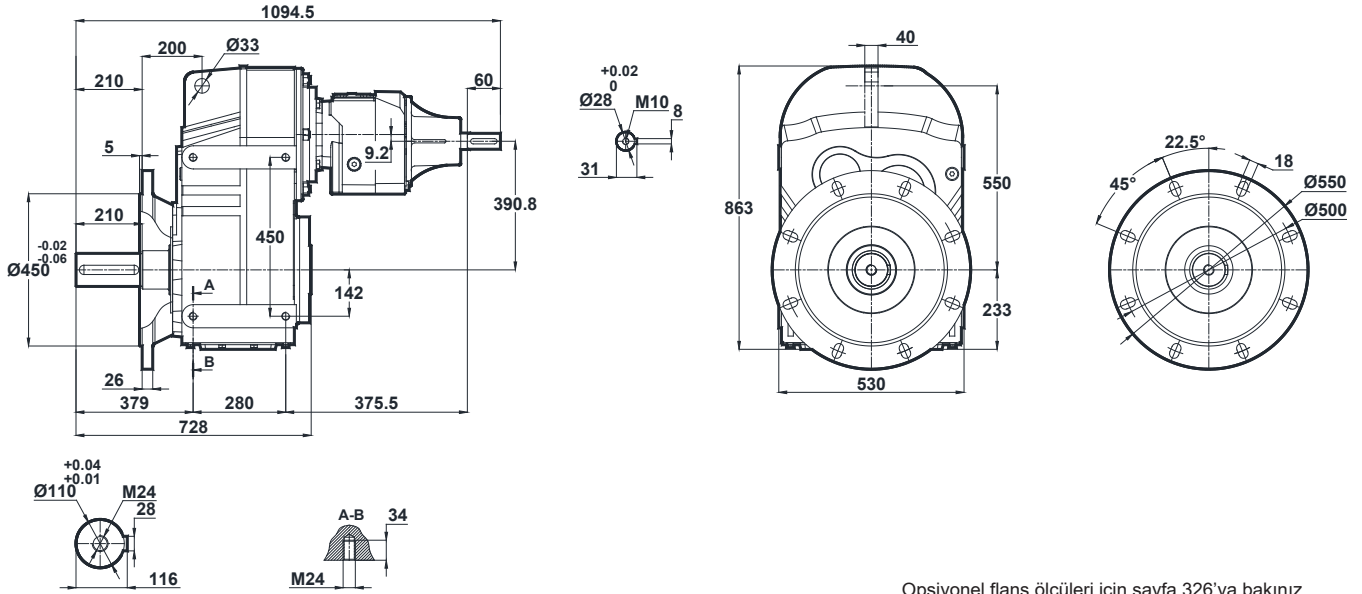

Opsiyonel flanş ölçüleri için sayfa 326'ya bakınız.  
Please see on page 326 for optional flange dimensions  
Siehe Seite 326 für auswählbare Flanschabmessungen

DT875.03  
DT876.03

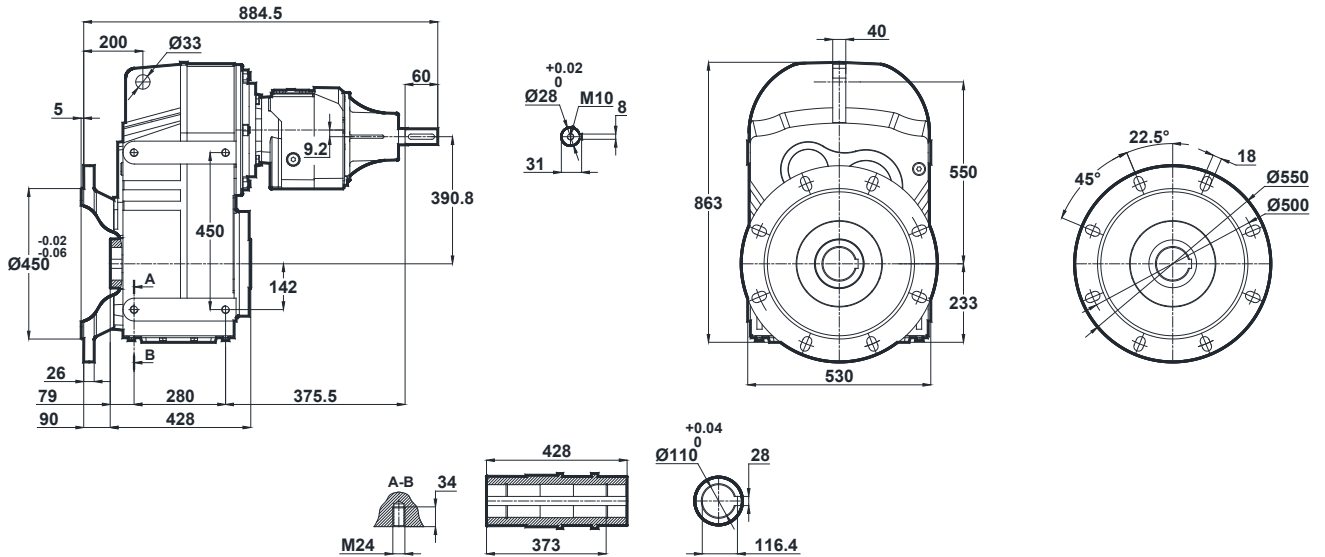

Opsiyonel flanş ölçüleri için sayfa 326'ya bakınız.  
Please see on page 326 for optional flange dimensions  
Siehe Seite 326 für auswählbare Flanschabmessungen

-Mil ucu çektirme deliği DIN 332 sayfa 2 / Tapped center hole according to DIN 332, sheet 2 / Zentrierung mit Gewinde nach DIN 332, Blatt 2

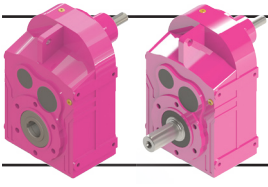

# Ölçü Sayfaları

## Dimension Pages

## Abmessungsseiten

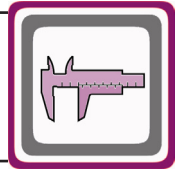

DT972.00  
DT973.00

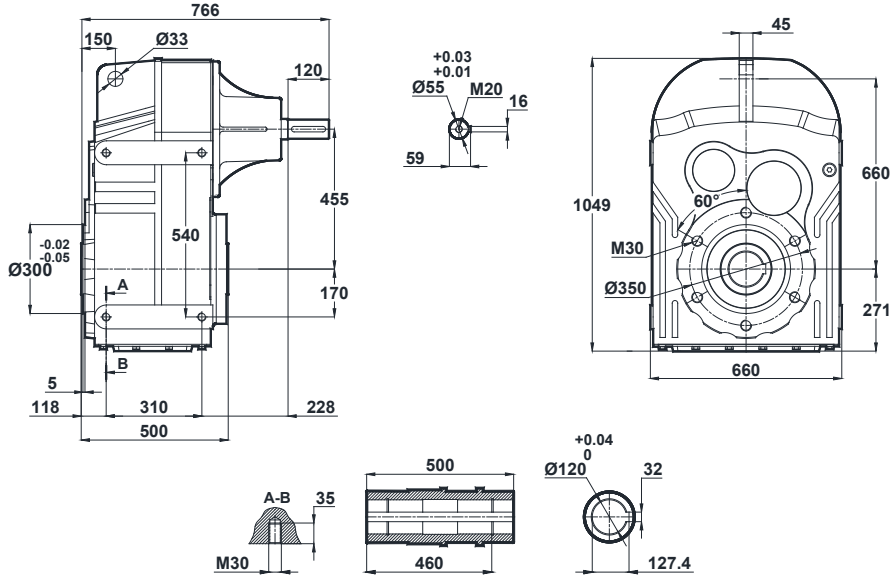

DT972.01  
DT973.01

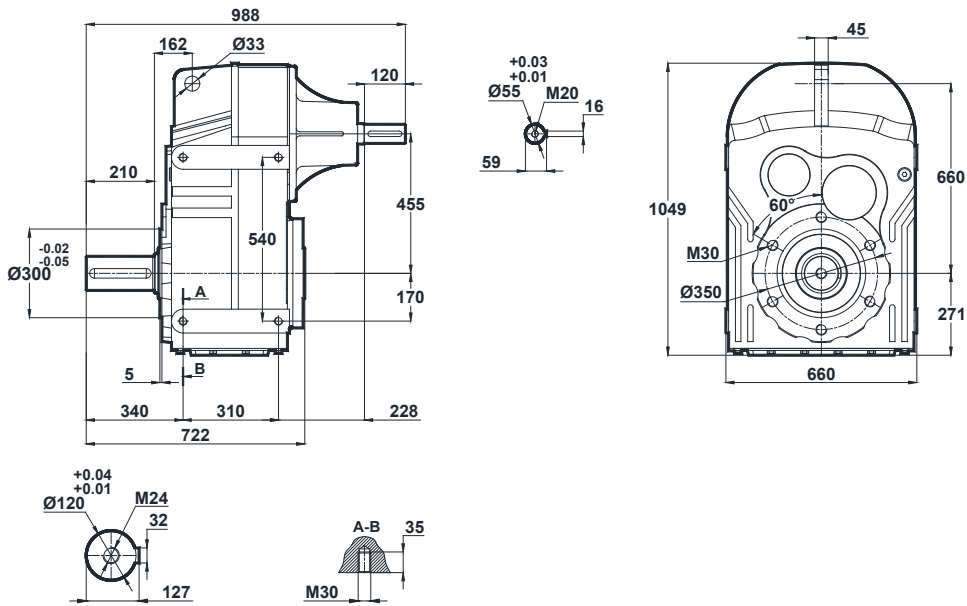

-Mil ucu çekirme deliği DIN 332 sayfa 2 / Tapped center hole according to DIN 332, sheet 2 / Zentrierung mit Gewinde nach DIN 332, Blatt 2

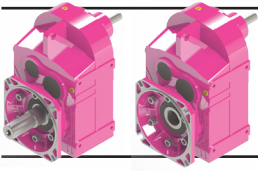

# Ölçü Sayfaları

## Dimension Pages

### Abmessungsseiten

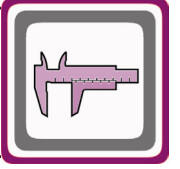

DT972.02  
DT973.02

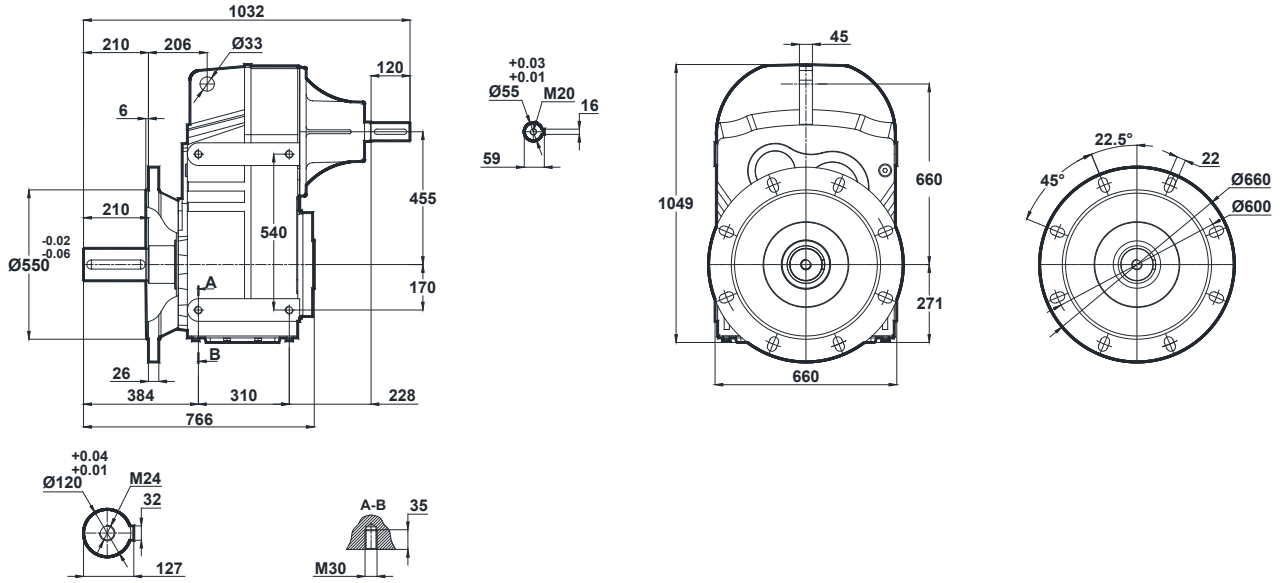

DT972.03  
DT973.03

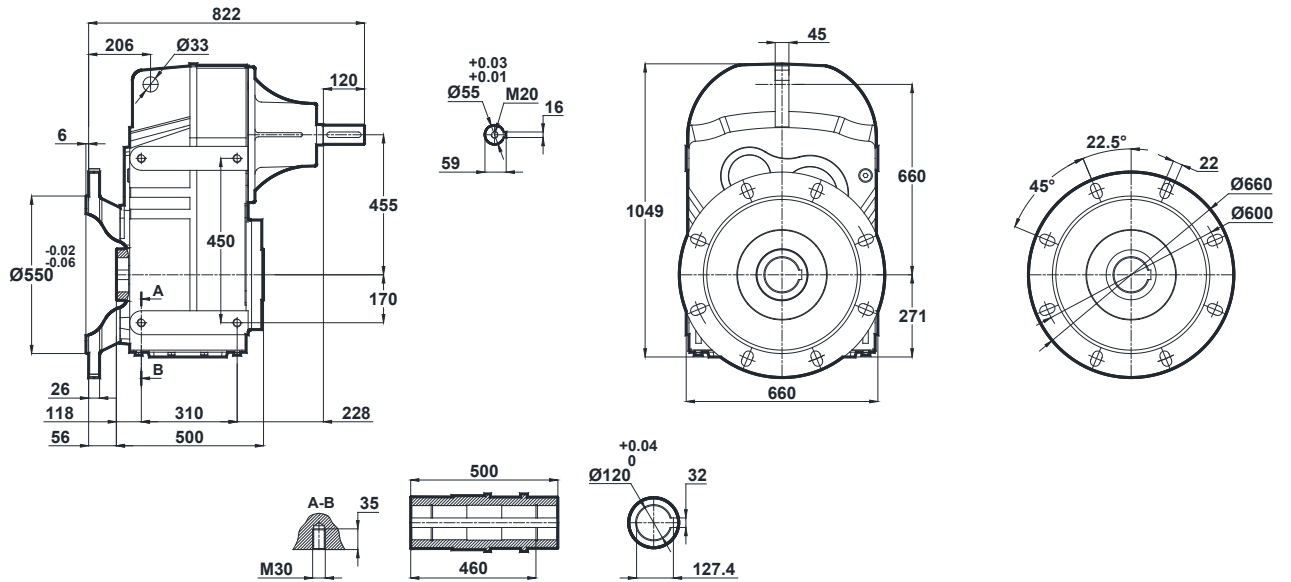

-Mil ucu çekirme deliği DIN 332 sayfa 2 / Tapped center hole according to DIN 332, sheet 2 / Zentrierung mit Gewinde nach DIN 332, Blatt 2

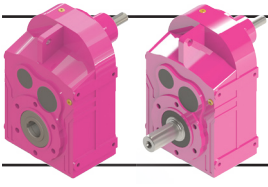

# Ölçü Sayfaları

## Dimension Pages

## Abmessungsseiten

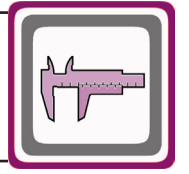

DT974.00

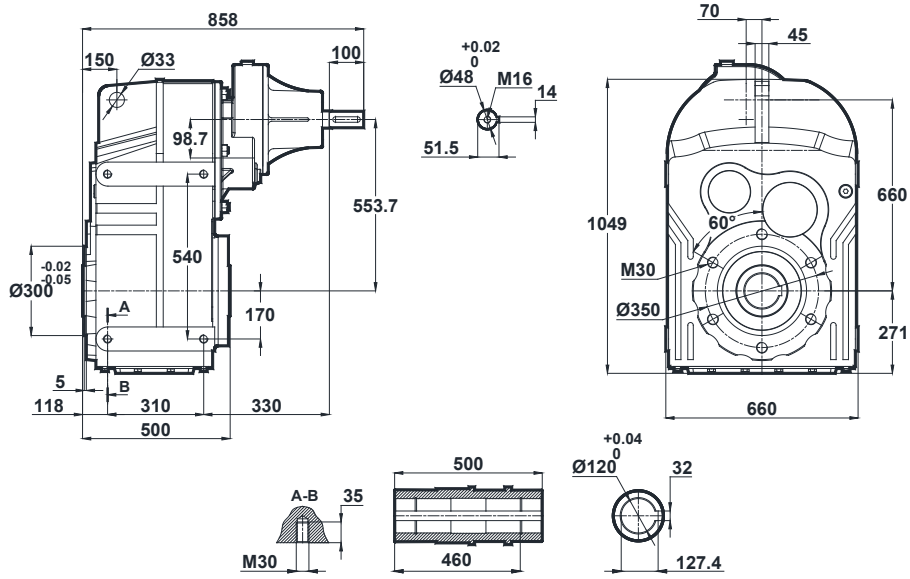

DT974.01

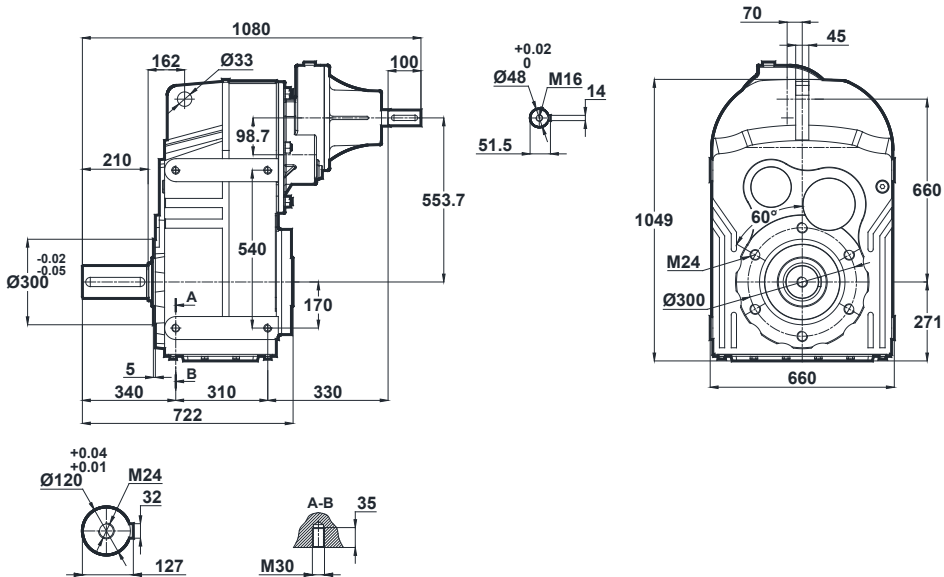

-Mil ucu çekirme deliği DIN 332 sayfa 2 / Tapped center hole according to DIN 332, sheet 2 / Zentrierung mit Gewinde nach DIN 332, Blatt 2

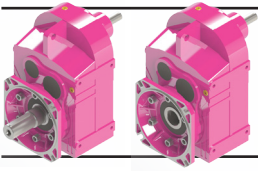

# Ölçü Sayfaları

## Dimension Pages

### Abmessungsseiten

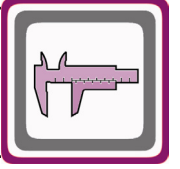

DT974.02

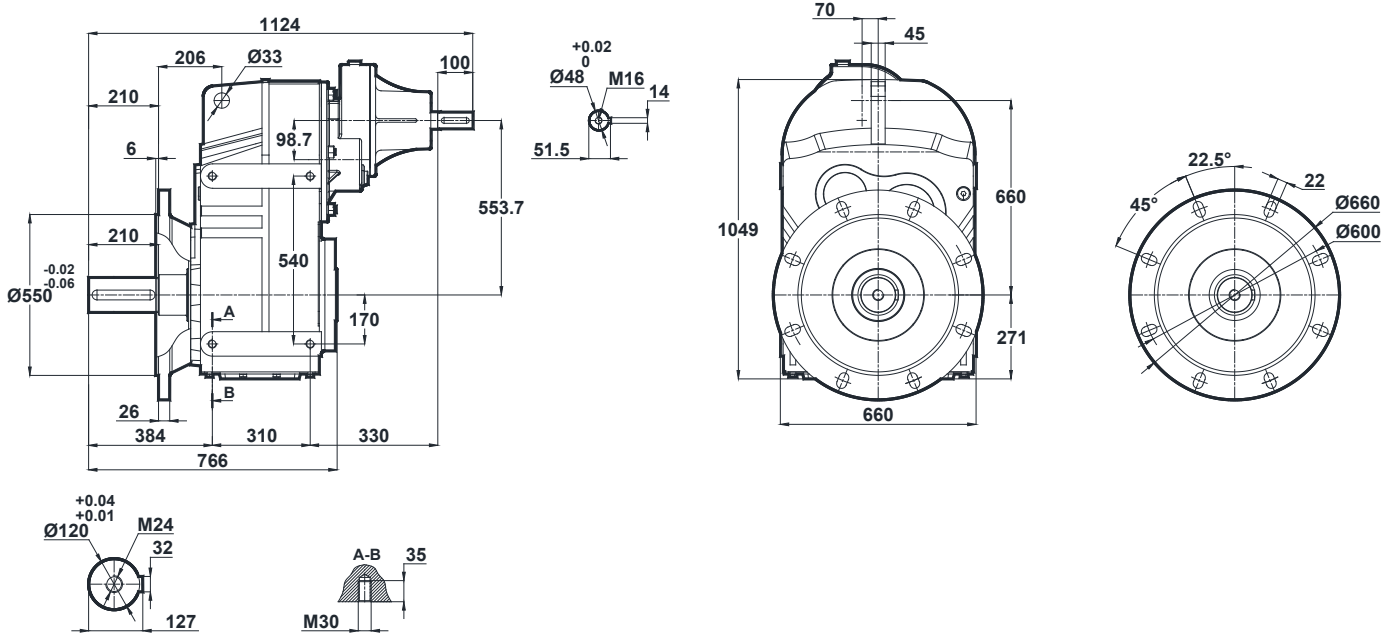

DT974.03

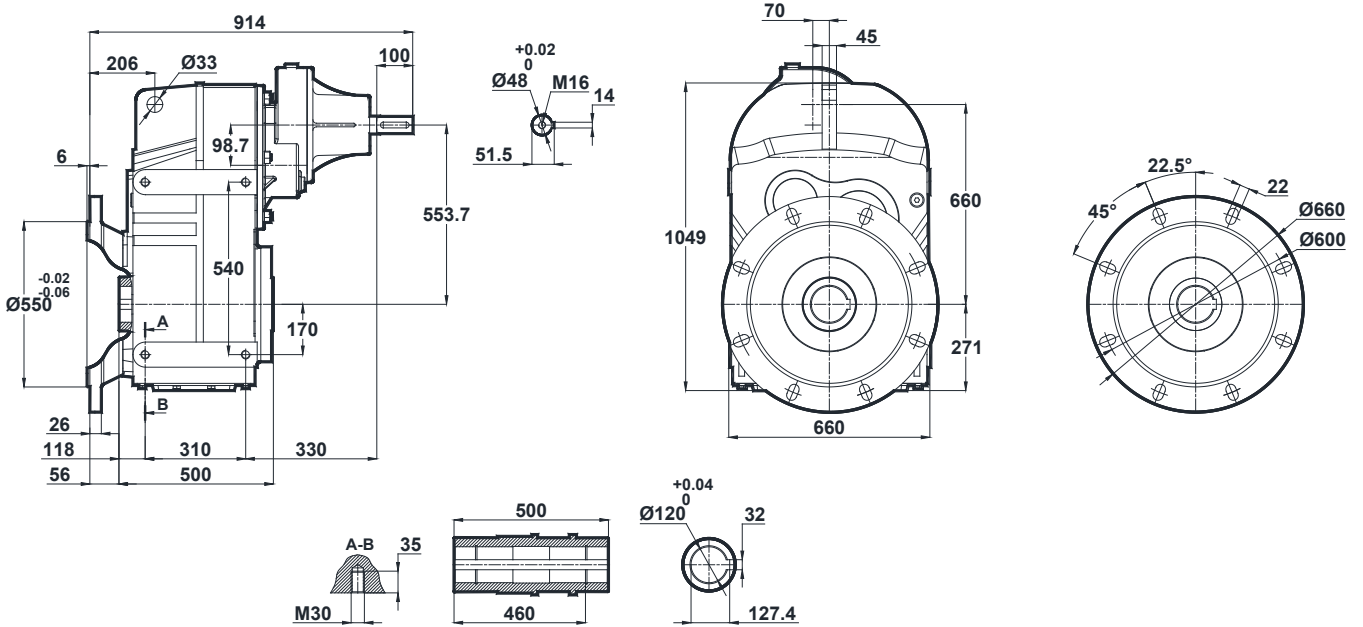

-Mil ucu çektirme deliği DIN 332 sayfa 2 / Tapped center hole according to DIN 332, sheet 2 / Zentrierung mit Gewinde nach DIN 332, Blatt 2

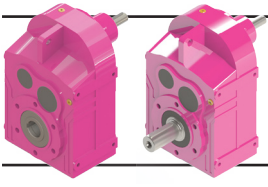

# Ölçü Sayfaları

## Dimension Pages

### Abmessungsseiten

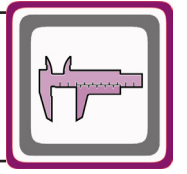

DT975.00  
DT976.00

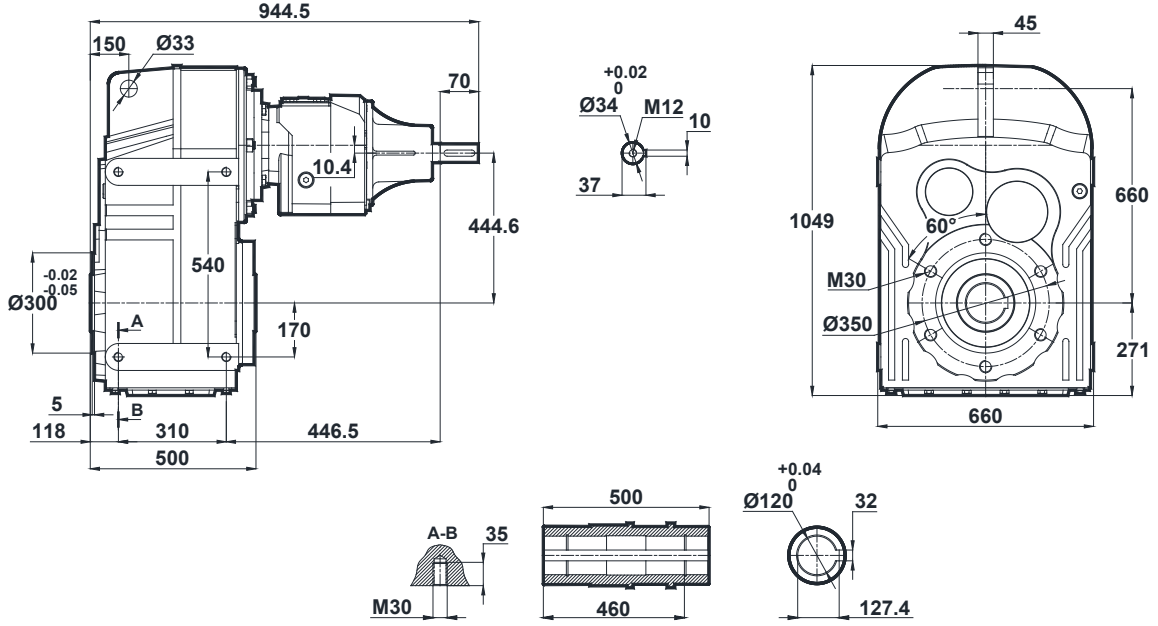

DT975.01  
DT976.01

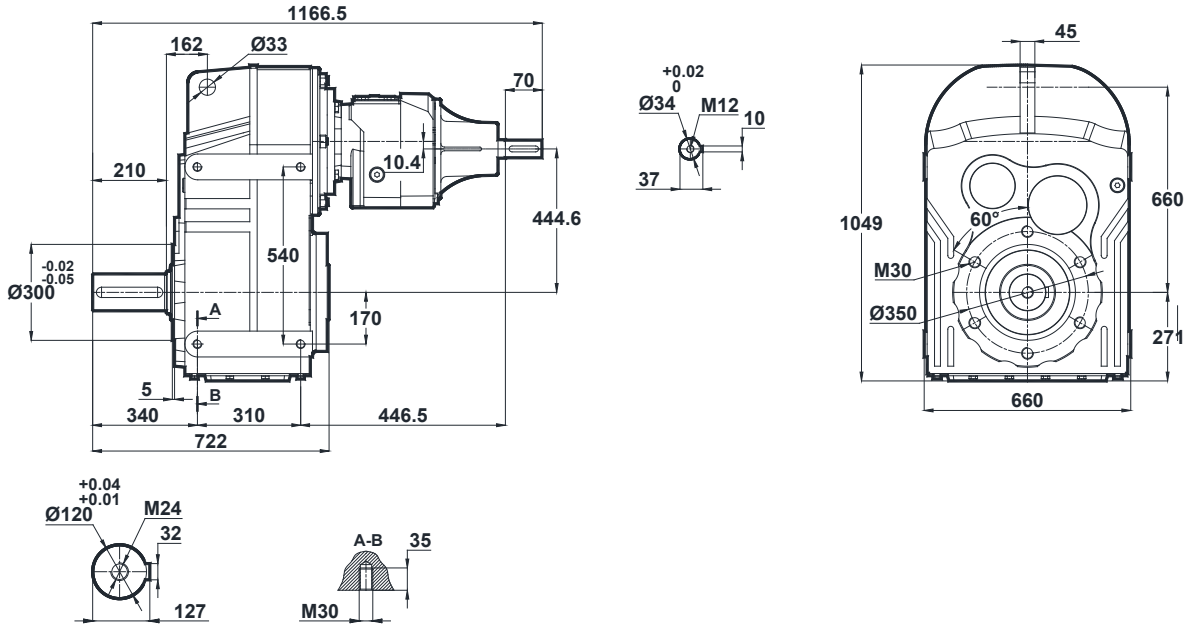

-Mil ucu çekirme deliği DIN 332 sayfa 2 / Tapped center hole according to DIN 332, sheet 2 / Zentrierung mit Gewinde nach DIN 332, Blatt 2

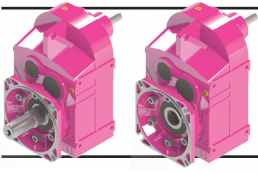

# Ölçü Sayfaları

## Dimension Pages

### Abmessungsseiten

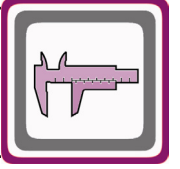

DT975.02  
DT976.02

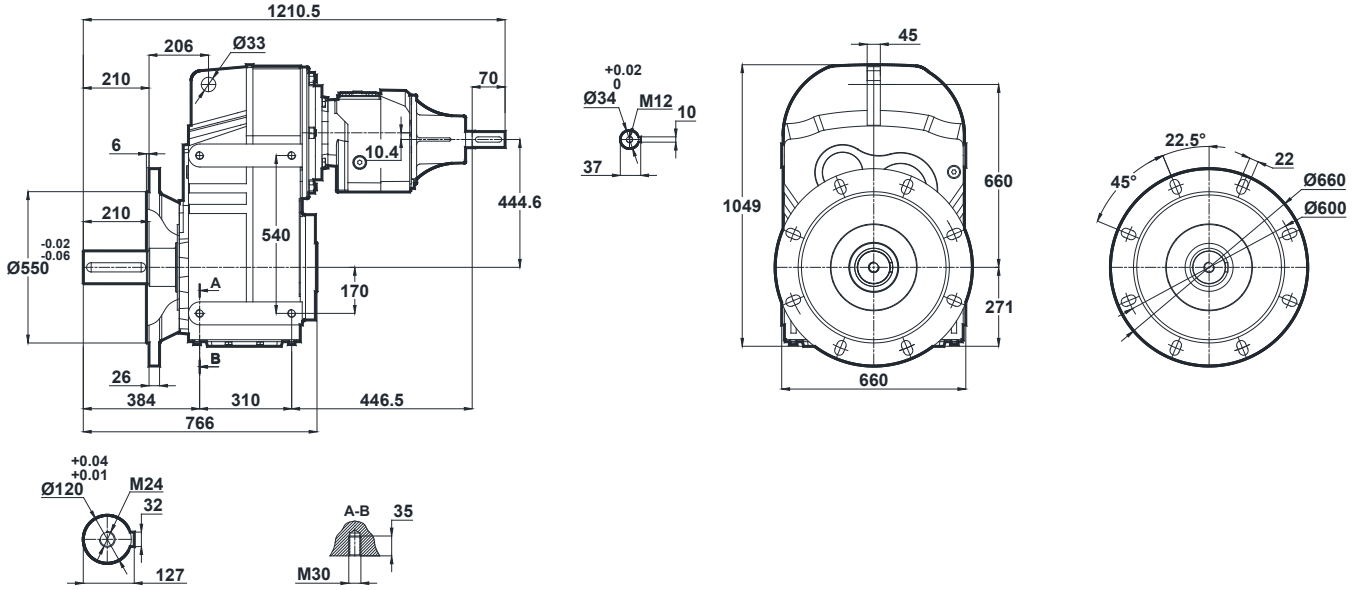

DT975.03  
DT976.03

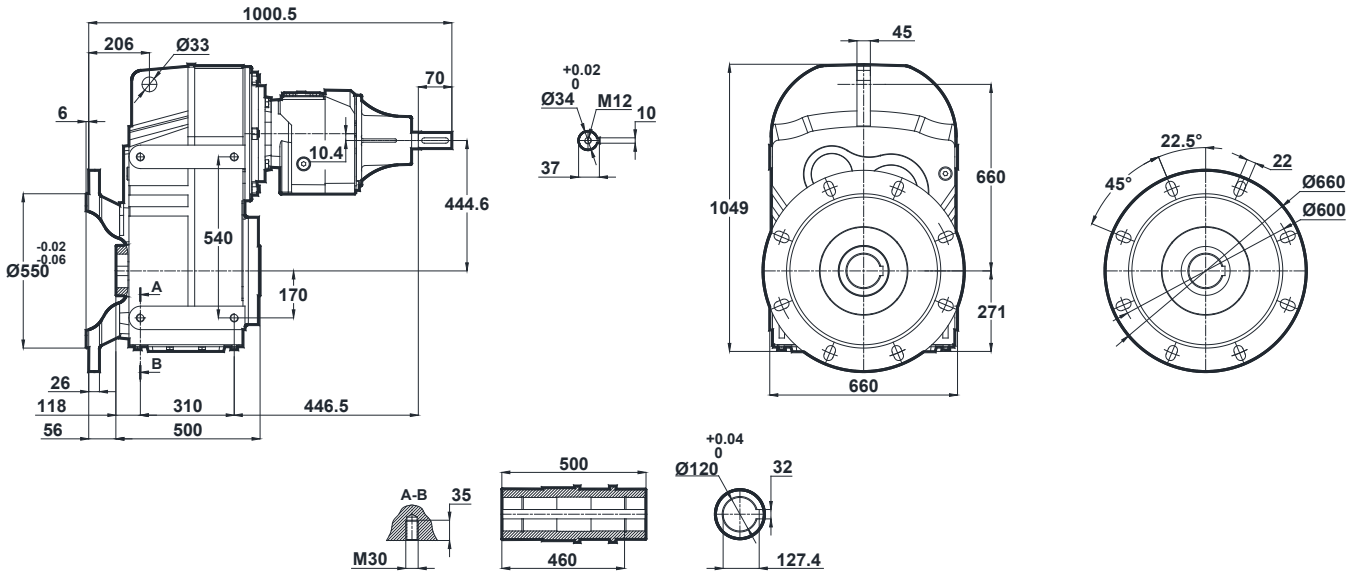

-Mil ucu çektirme deliği DIN 332 sayfa 2 / Tapped center hole according to DIN 332, sheet 2 / Zentrierung mit Gewinde nach DIN 332, Blatt 2

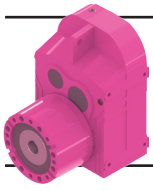

Ölçü Sayfaları  
Dimension Pages  
Abmessungenseiten

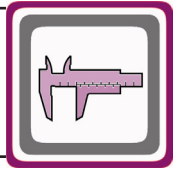

D.17.0E

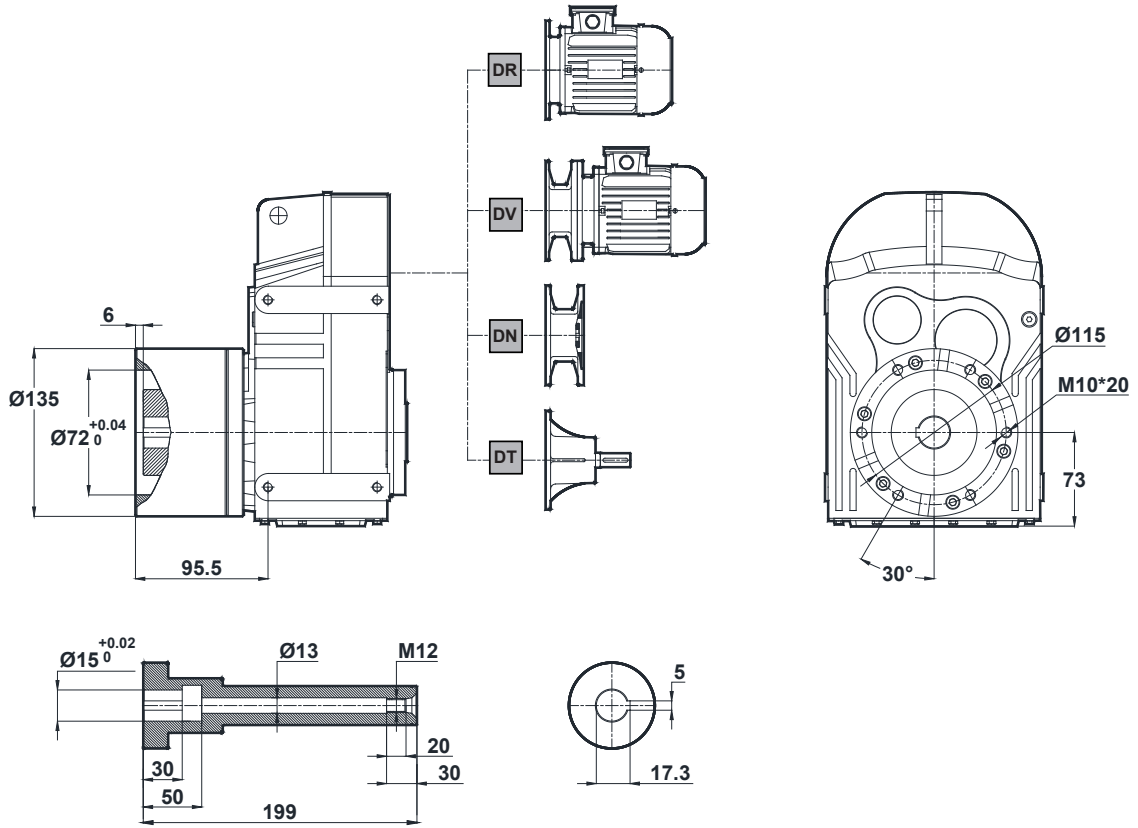

D.27.0E

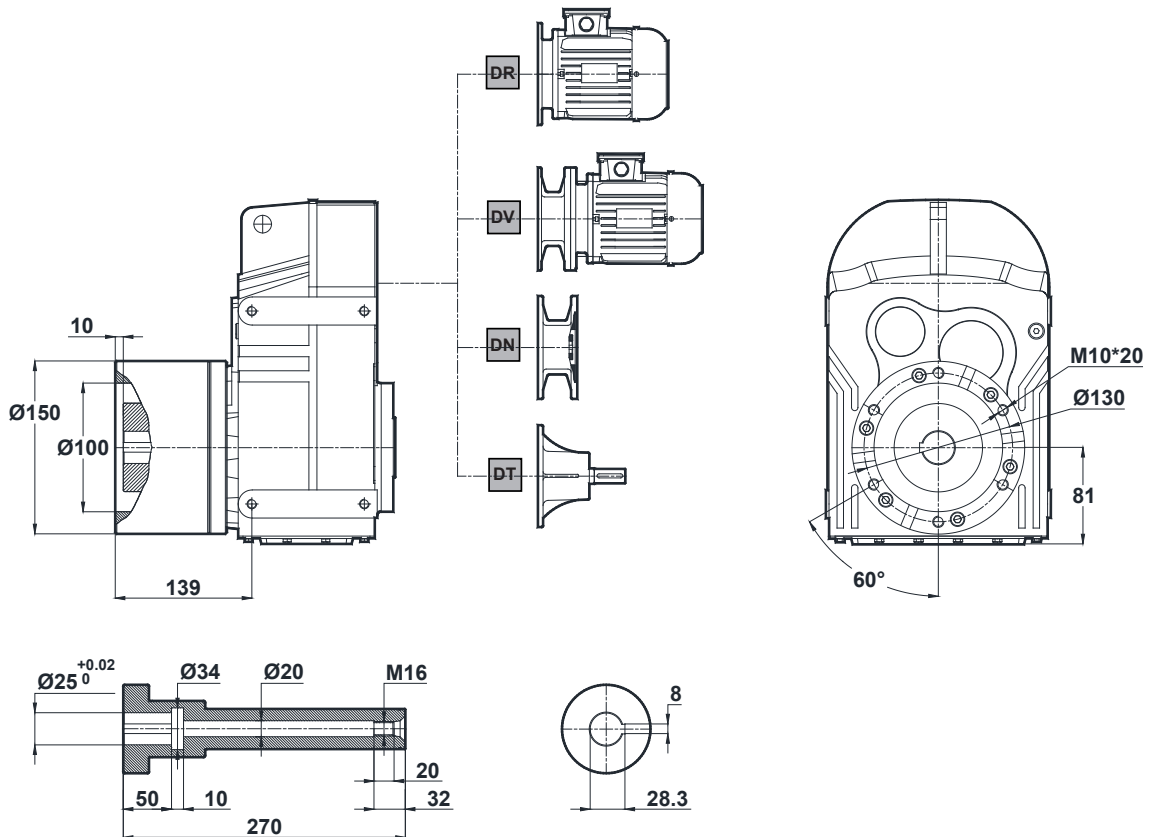

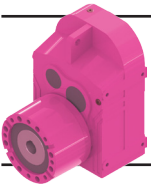

# Ölçü Sayfaları Dimension Pages Abmessungsseiten

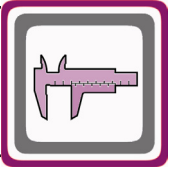

D.28.0E

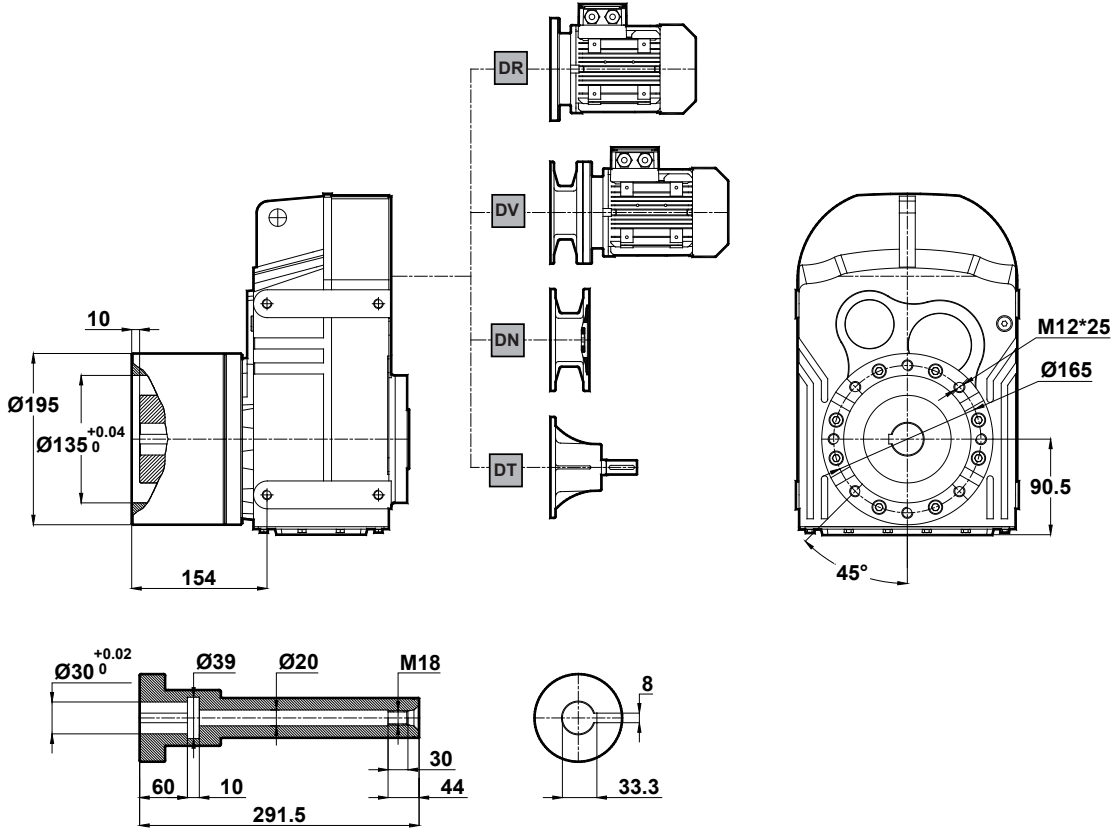

D.37.0E

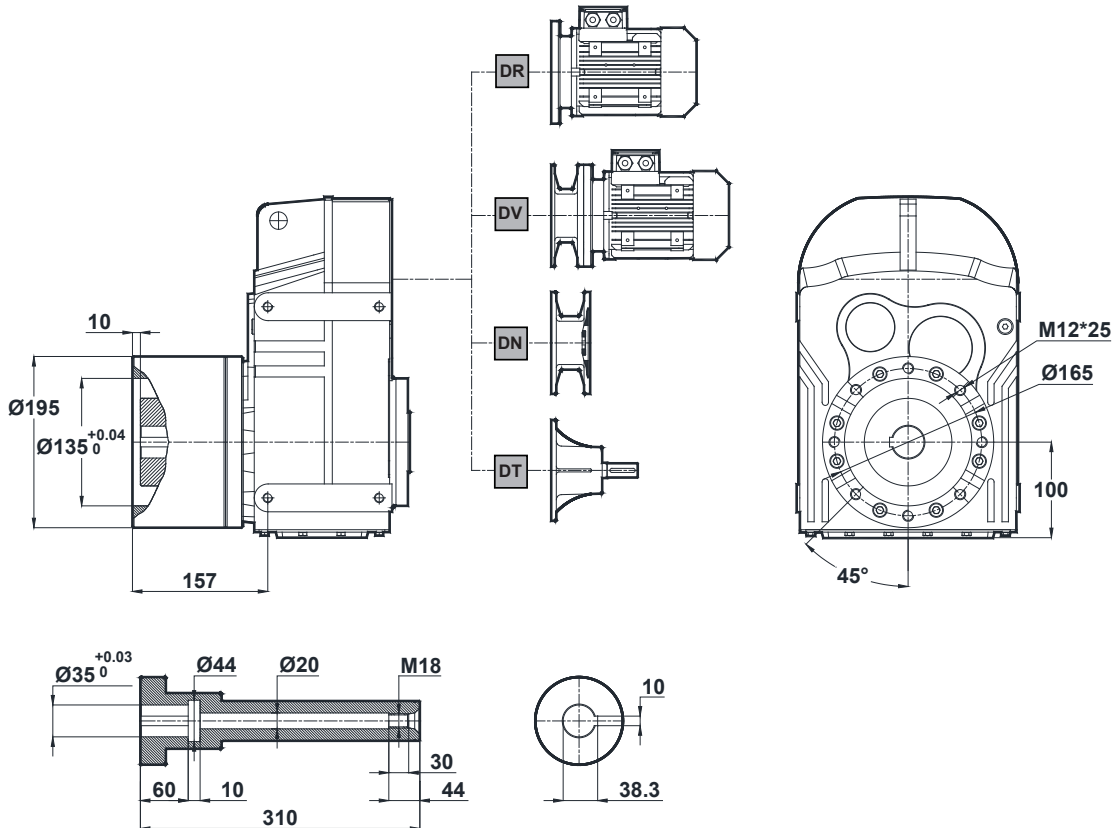

-Mil ucu çekirme deliği DIN 332 sayfa 2 / Tapped center hole according to DIN 332, sheet 2 / Zentrierung mit Gewinde nach DIN 332, Blatt 2

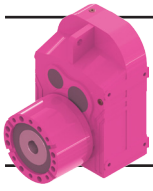

# Ölçü Sayfaları Dimension Pages Abmessungenseiten

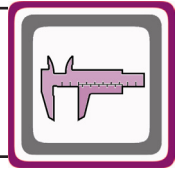

D.47.0E

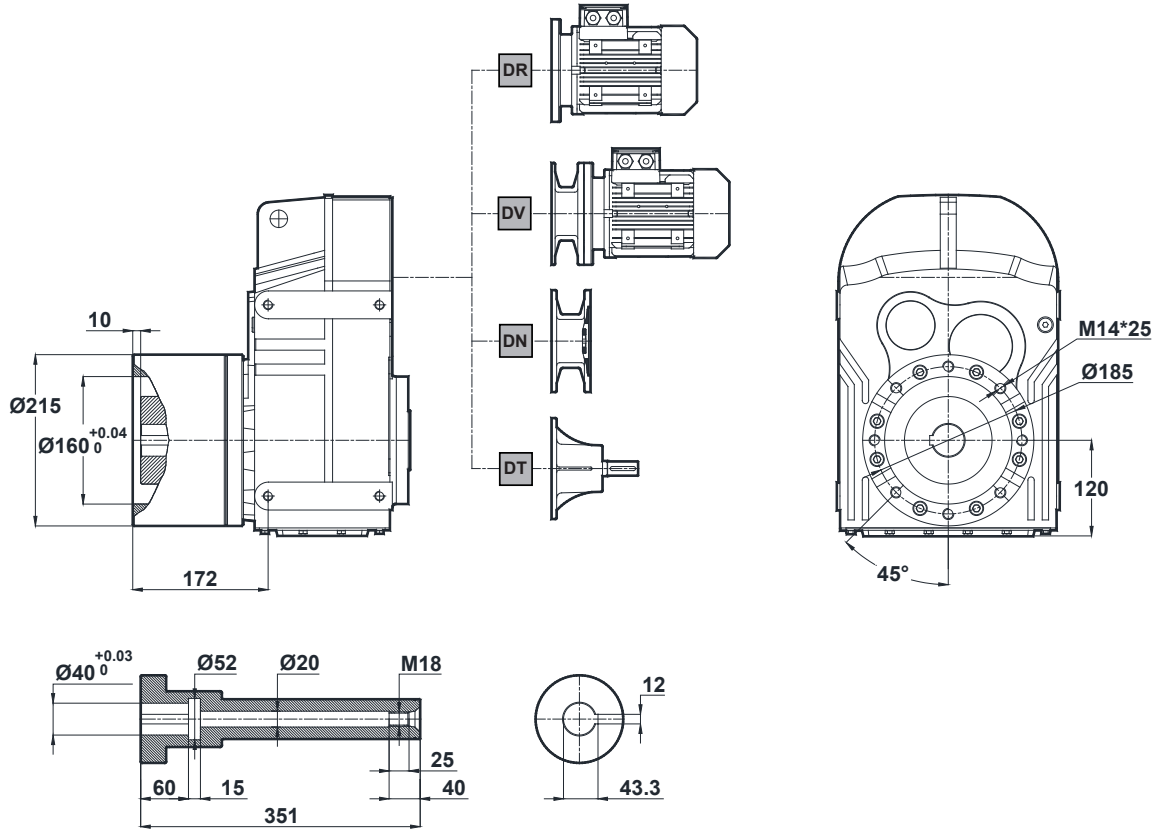

D.57.0E

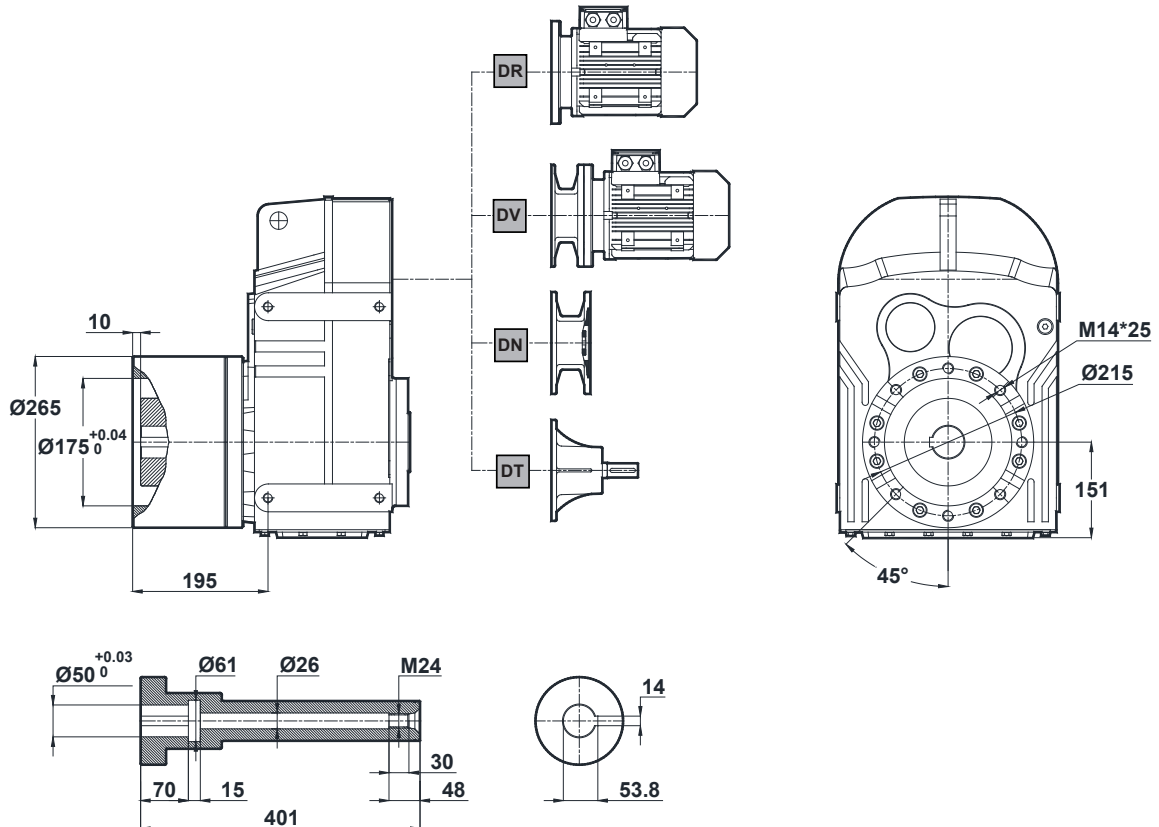

-Mil ucu çekirme deliği DIN 332 sayfa 2 / Tapped center hole according to DIN 332, sheet 2 / Zentrierung mit Gewinde nach DIN 332, Blatt 2

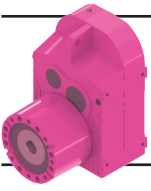

# Ölçü Sayfaları Dimension Pages Abmessungenseiten

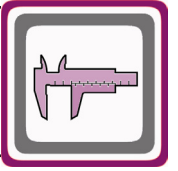

D.67.0E

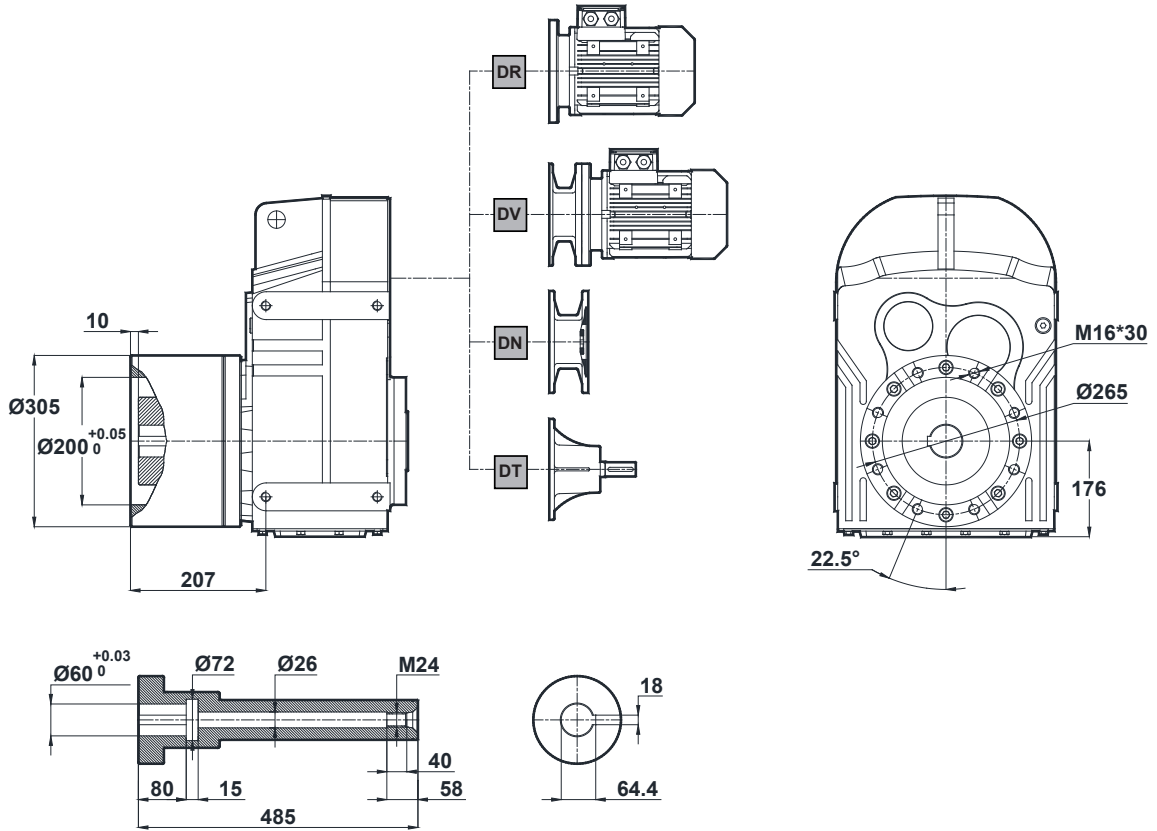

D.77.0E

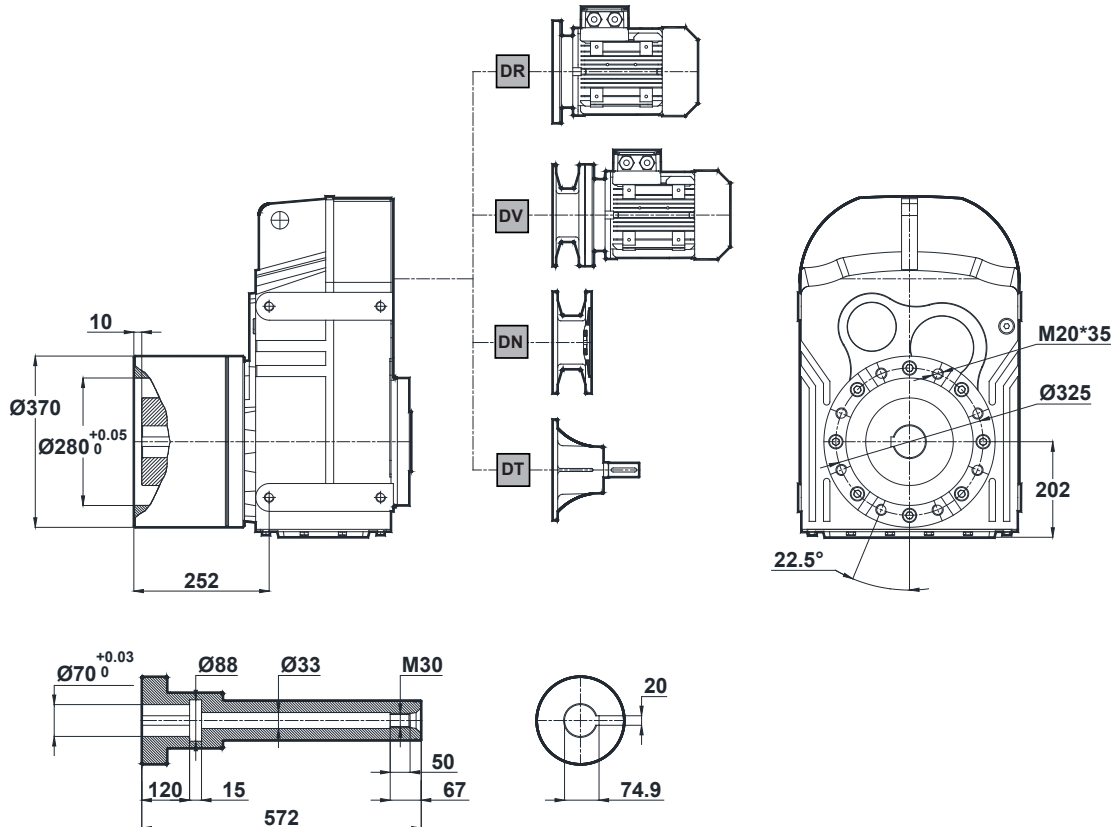

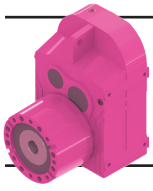

# Ölçü Sayfaları Dimension Pages Abmessungenseiten

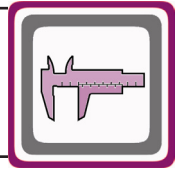

D.87.0E

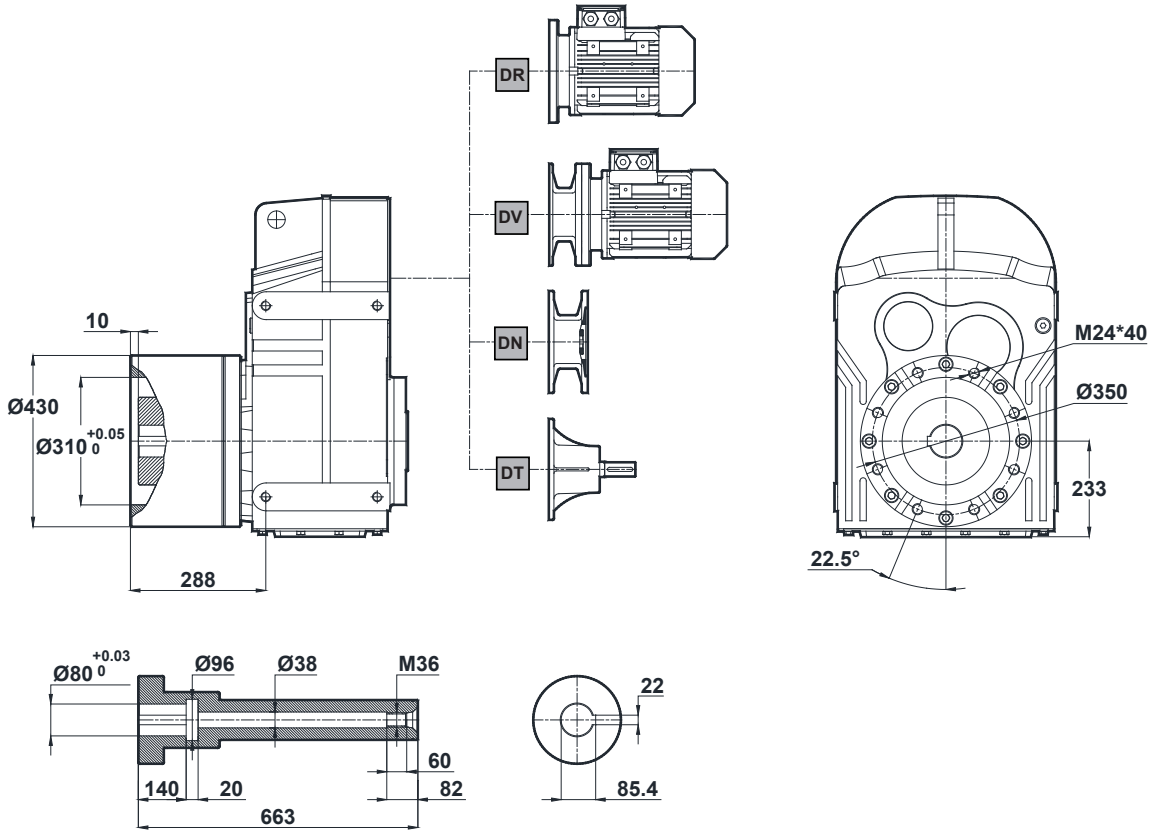

D.97.0E

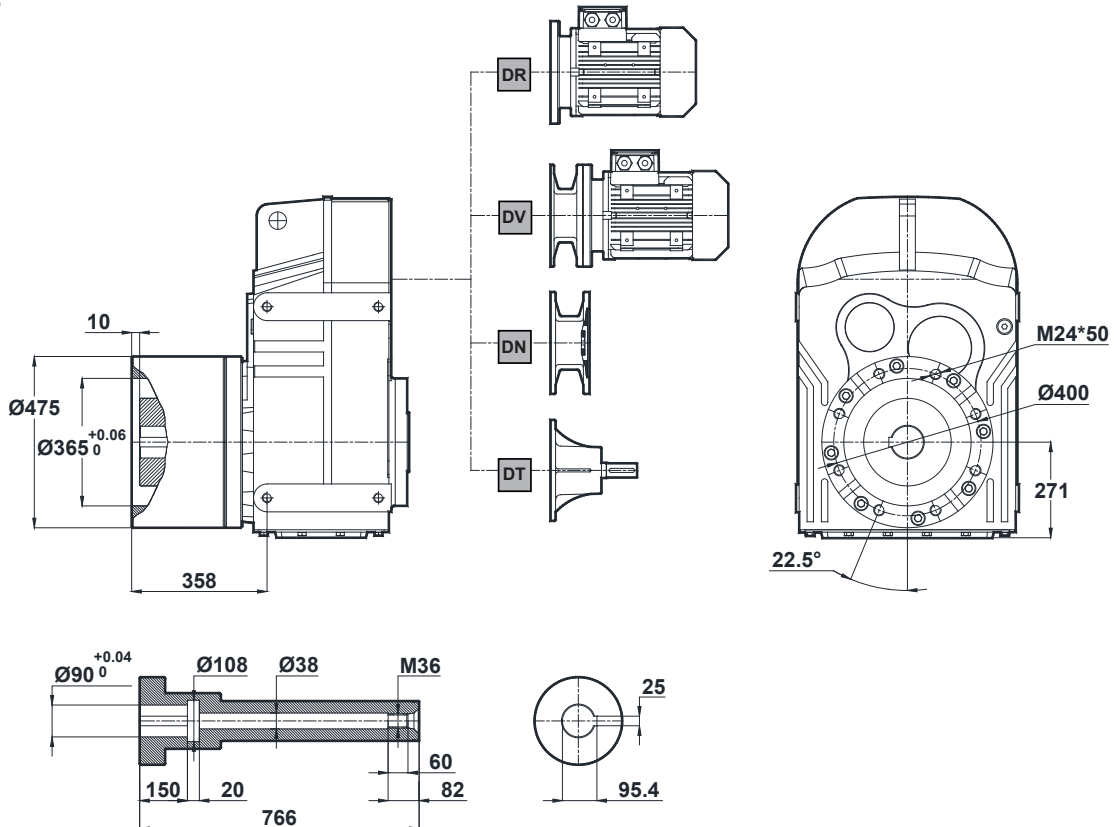



# Ölçü Sayfaları Dimension Pages Abmessungsseiten

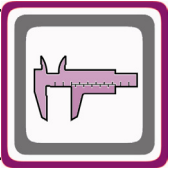

## D SERİSİ DELİK MİLLİ SIKMA BİLEZİKLİ REDÜKTÖRLER D SERIES HOLLOW SHAFT WITH SHRINK DISC CONNECTOR D SERIE HOHLWELLE MIT SCHRUMPFSCHEIBE

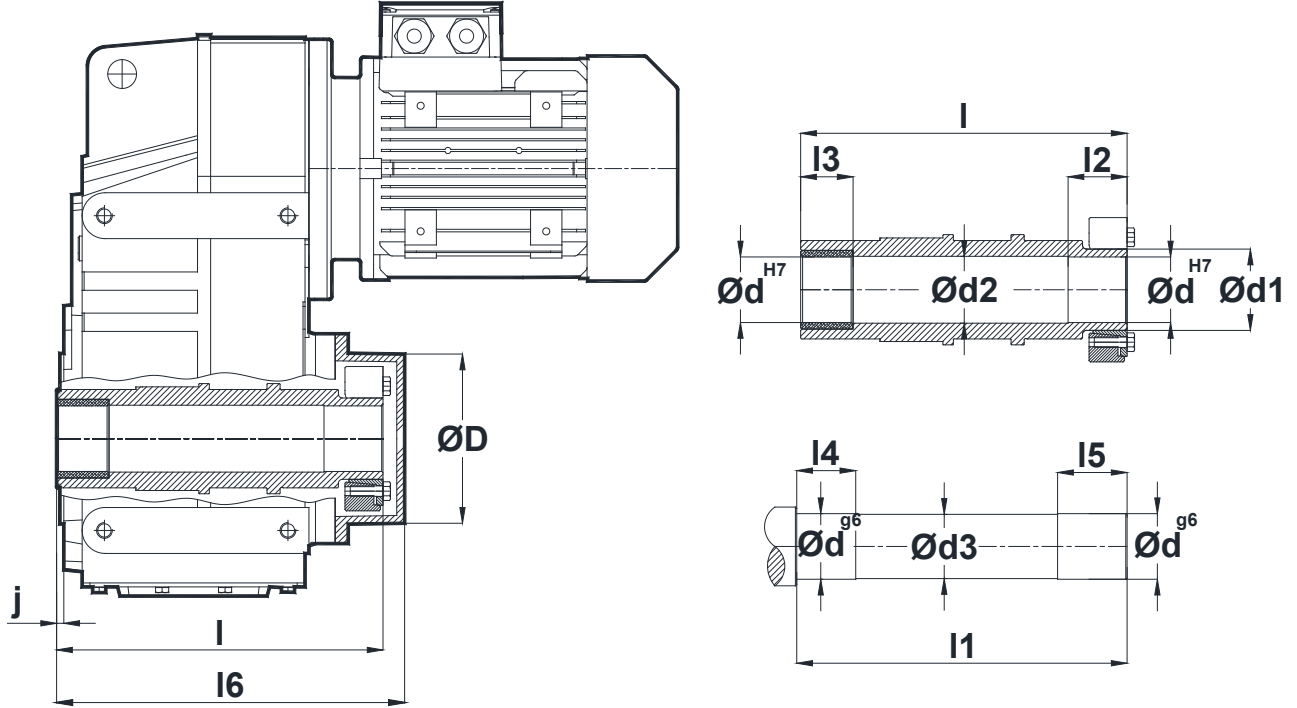

Istenilen yüzey pürüzlülüğü değeri:  $Rz \leq 16 \mu m$

Desired surface roughness value:  $Rz \leq 16 \mu m$

Gewünschtes Oberflächenrauheitswert:  $Rz \leq 16 \mu m$

Tipi Type Typ	ØD	Ød	Ød1	Ød2	Ød3	I	I1	I2	I3	I4	I5	I6	j	M	Z	Ta[Nm]
D.07.. 0S	73	25	30	26	24	131	134	30	20	25	38	142,5	4	M5	6	4
D.17.. 0S	85	30	36	31	29	146	149	30	20	25	38	162	4	M6	5	12
D.27.. 0S	94	35	44	36	34	186	189	35	25	30	43	201	4.5	M6	7	12
D.28.. 0S	104	40	50	41	39	197	200	35	30	35	43	213	5	M6	8	12
D.37.. 0S	106	40	50	41	39	216	219	40	35	40	48	232	6	M6	8	12
D.47.. 0S	129	50	62	51	49	249	252	45	40	45	53	266	5.5	M6	10	12
D.57.. 0S	159	60	75	61	59	282	285	50	45	50	58	305	5.5	M8	7	30
D.67.. 0S	164	70	80	71	69	345	348	55	50	55	63	366	6	M8	7	30
D.77.. 0S	204	90	110	91	89	418	421	70	60	70	83	440	7.5	M10	9	59
D.87.. 0S	252	110	140	111	109	492	495	80	70	80	93	519	9	M12	10	100
D.97.. 0S	288	120	155	121	119	570	573	90	80	90	103	593	10	M12	12	100

M: Civata Ölçüsü / Bolt dimension / Muttergröße

Z: Civata Sayısı / Bolt Quantity / Anzahl von Muttern

Ta: Sıkma Momenti / Tightening Torque / Schrupfmoment



# Ölçü Sayfaları Dimension Pages Abmessungenseiten

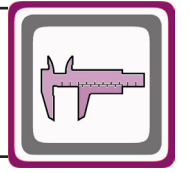

## D serisi redüktör kovan ölçüleri Hollow Shaft Dimensions for D Series Gearboxes Hohlwelleabmessungen Von D Serie Getrieben

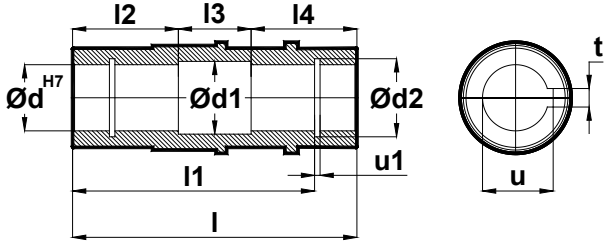

Tip Type Typ	d	d1	d2	l	l1	l2	l3	l4	u1	t	u
D.07..	25	26	26.2	108	94	40	28	40	1.3	8	28.3
D.17..	30	31	31.4	120	105	45	30	45	1.3	8	33.3
D.27..	35	36	37	157	132	60	37	60	1.6	10	38.3
D.28..	40	41	42.5	166	142	64	38	64	1.85	12	43.3
D.37..	40	41	42.5	185	156	70	45	70	1.85	12	43.3
D.47..	50	51	53	215	183	82	51	82	2.15	14	53.8
D.57..	60	61	63	246	210	96	54	96	2.15	18	64.4
D.67..	70	71	73	308	270	110	88	110	2.65	20	74.9
D.77..	90	91	93.5	363	313	135	93	135	3.15	25	95.4
D.87..	110	111	114	428	373	160	108	160	4.15	28	116.4
D.97..	120	121	124	500	460	180	140	180	4.15	32	127.4

## Moment kolu bağlantı detayı Torque Arm Mounting details Drehmomentstütze montage zeichnungen

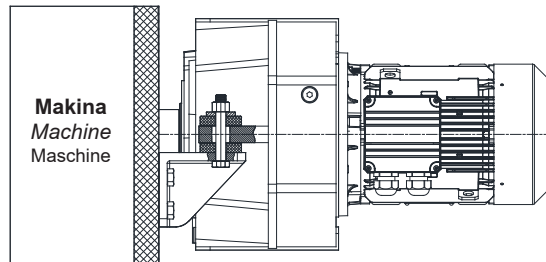
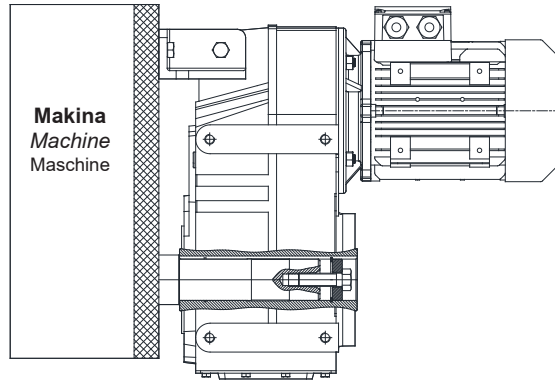



# Ölçü Sayfaları Dimension Pages Abmessungsseiten

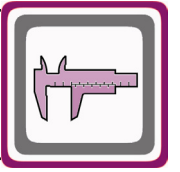

**D SERİSİ REDÜKTÖRLERDE TAVSİYE EDİLEN MİL BOYU MONTAJ-DEMONTAJ ŞEKLİ VE AKSESUARLARI**  
**ADVISED SHAFT DIMENSIONS AND ACCESSORIES ASSEMBLING FOR D SERIES GEARBOXES**  
**EMPFOHLENE WELLEN MASSEN UND VERBINDUNGSELEMENTE BEI MONTAGE FÜR D SERIE GETRIEBE**

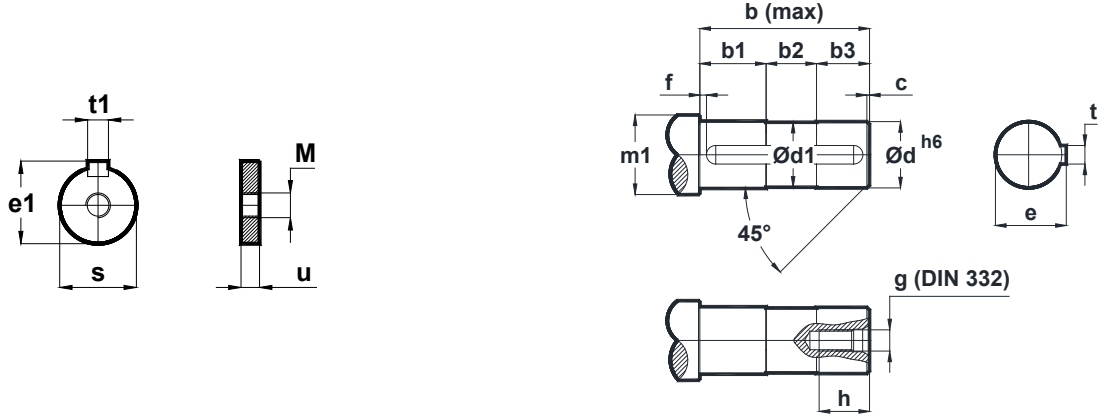

Tipi Type Typ	s	u	e1	t1	M	d	d1	m1	f	b	b1	b2	b3	c	g	h	e	t
D.07..	24.7	8	28	7.5	M12	25	24	30	5	82	45	18	19	1	M10	24	28	8
D.17..	29.7	10	33	7.5	M12	30	29	36		89	50	20	19	1	M10	24	33	8
D.27..	34.7	12	38	9.5	M16	35	34	43		114	65	27	22	1	M12	30	38	10
D.28..	39.7	12	43	11.5	M20	40	39	50		124	69	28	27	2	M16	38	43	12
D.37..	39.7	12	43	11.5	M20	40	39	50		138	75	35	28	2	M16	38	43	12
D.47..	49.7	12	53.5	13.5	M20	50	49	60		165	87	41	37	3	M16	38	53.5	14
D.57..	59.7	16	64	17.5	M24	60	59	75		188	101	44	43	3	M20	44	64	18
D.67..	69.7	16	74.5	19.5	M24	70	69	85		248	115	78	55	4	M20	44	74.5	20
D.77..	89.7	20	95	24.5	M30	90	89	110		287	140	83	64	4	M24	52	95	25
D.87..	109.7	20	116	27.5	M30	110	109	130		347	165	98	84	4	M24	52	116	28
D.97..	119.7	20	127	31	M30	120	119	140		434	185	130	119	4	M24	52	127	32

**Mil Çektirme / Shaft Mounting / Einziehen**

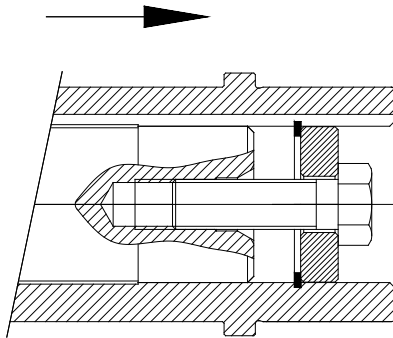

**Mil Çıkartma / Shaft Pulling Out / Heraus Drücken**

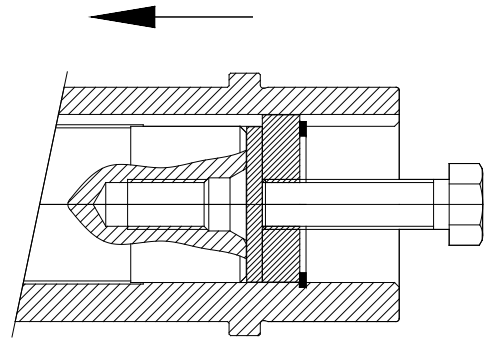

**6 Köşe Başlı Cıvata / 6 Contour Bolt / Sechskantschraube**  
(DIN ISO 4014 . DIN ISO 4017)  
(DIN ISO 8765)



# Ölçü Sayfaları Dimension Pages Abmessungenseiten

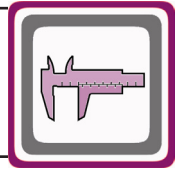

## D Serisi Redüktörlerde Moment Kolu Bağlantı Ölçüleri Torque Arm Mounting Dimensions for D Series Gear Units Montageabmessungen der Drehmomentstütze von D Serie Getriebe

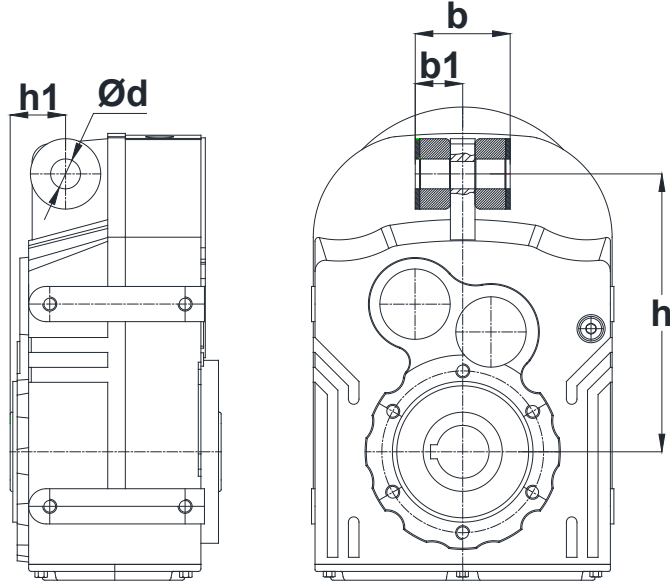

Tip Type Typ	d	b	b1	h	h1
D.07..	14	42	21	147	26.5
D.17.	17	54	27	158	31.5
D.27.	17	54	27	170	32
D.28.	17	54	27	198	40.5
D.37.	17	56	28	218	41
D.47.	22	80	40	278	50
D.57.	22	86	43	346	62
D.67.	26	110	55	395	70
D.77.	26	116	58	485	88
D.87.	32	160	80	550	110
D.97.	32	165	82.5	660	150



# Ölçü Sayfaları Dimension Pages Abmessungsseiten

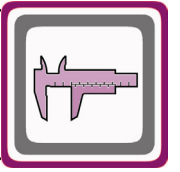

**D.07.. - D.97.. DIN 5480 ÇOKLU KAMA ÖLÇÜLERİ**  
D.07.. - D.97.. DIMENSIONS OF SPLINED HOLLOW SHAFT TO DIN 5480  
D.07.. - D.97.. ABMESSUNGEN VON HOHLWELLE MIT VIELKEILVERZÄHNUNG NACH DIN 5480

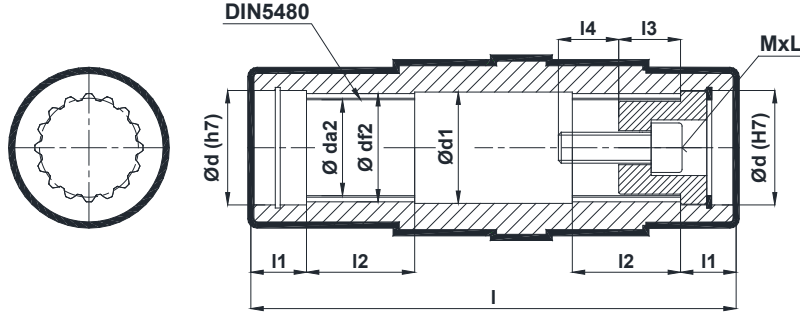

Tip Type Typ	DIN5480	$\varnothing d$ (H7)	$\varnothing d1$	$\varnothing d2$	$\varnothing da2$	$\varnothing df2$	l	l1	l2	l3	l4	MxL
D07	N25x1.25x30x18x9H	27	26	48	22.5	25.25	104	17	22	20	20	M10x60
D17	N30x1,25x30x22x9H	32	31	53	27,5	30,25	120	18	25	20	20	M10x60
D27 D28	N35x2x30x16x9H	37	36	58 63,5	31	35,4	157 166	18	35	20	20	M10x90 M10x100
D37	N45x2x30x21x9H	47	46	74	41	45,4	185	25	45	24	32	M16x110
D47	N50x2x30x24x9H	55	51	84	46	50,4	215	25	55	24	32	M16x130
D57	N65x2x30x31x9H	72	66	104	61	65,4	246	25	65	30	40	M20x150
D67	N70x2x30x34x9H	72	71	119	66	70,4	308	25	75	30	40	M20x210
D77	N85x3x30x27x9H	90	86	139,5	79	85,6	363	26	90	30	40	M20x240
D87	N100x4x30x24x9H	110	101	169	92	100,8	428	30	105	41	50	M24x290
D97	N120x4x30x28x9H	130	121	179	112	120,8	500	35	120	41	50	M24x340

**NOT: Makina mil boyu tek tarafli çoklu kama uzunluk ölçüsüne (l1+l2) göre yapılmalıdır! Delik mil boydan boya kullanılmaz!**  
**NOTE: The customer shaft length must be made only for one sided (l1+l2) splined hollow shaft dimensions! The total length (l) of the splined hollow shaft can not be used in this case!**

**HINWEIS: Die Kundenwellenlänge muss nur für einseitig (l1+l2) Hohlwelle mit Vielkeilverzahnung gefertigt werden. Die Gesamtlänge der Hohlwelle (l) kann in diesem Fall nicht verwendet werden!**

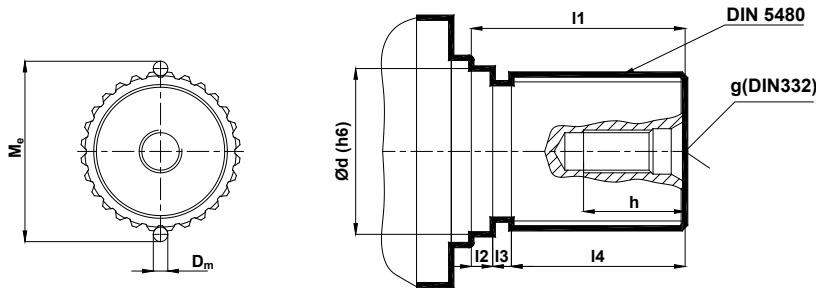

Tip Type Typ	DIN5480	$\varnothing d$	l1	l2	l3	l4	Me	Dm	g (DIN332)
D07	W25x1.25x30x18x8f	27	44	10	7	27	28,01 <sup>0/-0,03</sup>	2,75	M10x24
D17	W30x1,25x30x22x8f	32	48	11	7	30	33,05 <sup>0/-0,04</sup>	2,75	M10x24
D27 D28	W35x2x30x16x8f	37	58	11	7	40	38,94 <sup>0/-0,05</sup>	4,00	M10x24
D37	W45x2x30x21x8f	47	75	18	7	50	48,88 <sup>0/-0,05</sup>	4,00	M16x38
D47	W50x2x30x24x8f	55	85	18	7	60	54,16 <sup>0/-0,05</sup>	4,00	M16x38
D57	W65x2x30x31x8f	72	95	17	8	70	68,99 <sup>0/-0,06</sup>	4,00	M20x44
D67	W70x2x30x34x8f	72	105	17	8	80	74,18 <sup>0/-0,06</sup>	4,00	M20x44
D77	W85x3x30x27x8f	90	121	16	10	95	91,02 <sup>0/-0,05</sup>	6,00	M20x44
D87	W100x4x30x24x8f	110	140	20	10	110	108,37 <sup>0/-0,06</sup>	8,00	M24x52
D97	W120x4x30x28x8f	130	160	23	12	125	127,89 <sup>0/-0,06</sup>	8,00	M24x52

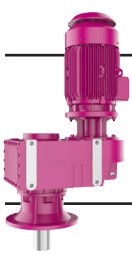

# Ölçü Sayfaları Dimension Pages Abmessungsseiten

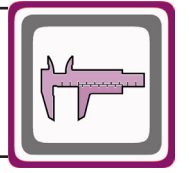

## D SERİSİ DELİK MİLLİ KARIŞTIRICI REDÜKTÖRLERİ ÖLÇÜLERİ D SERIES DRYWELL GEARBOXES WITH HOLLOW SHAFT DIMENSIONS D SERIEN DRYWELL GETRIEBE MIT HOHLWELLE ABMESSUNGEN

### 0A Delik Mil Opsiyonu 0A Hollow Shaft Option 0A Hohlwelle-Ausführung

### Çıkış Flanşı Output Flange Abtriebsflansch

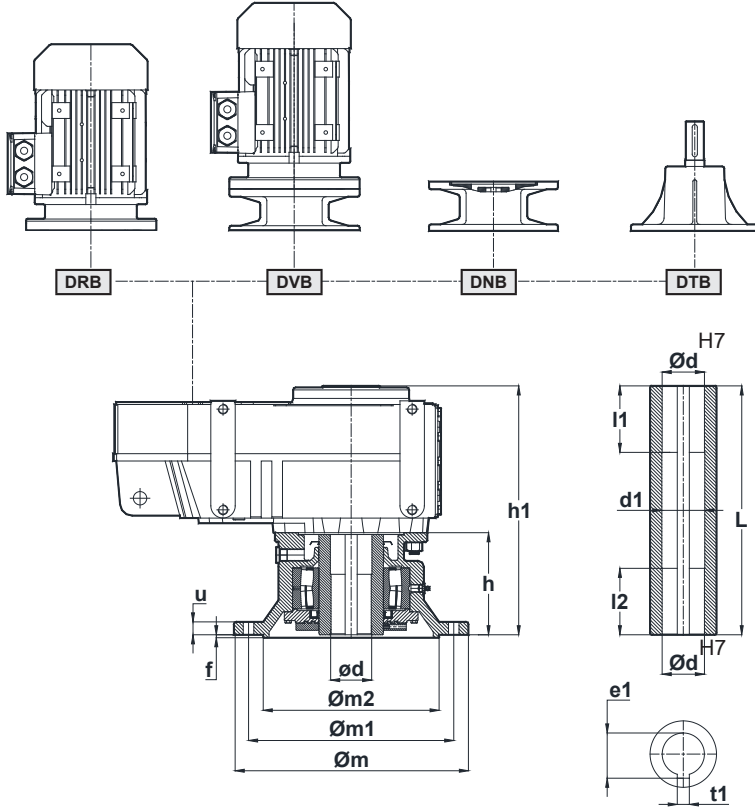

D.28 - D.67

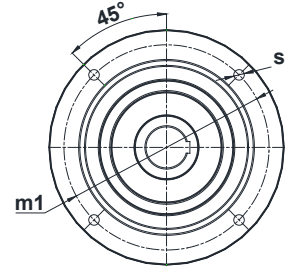

D.77 - D.97

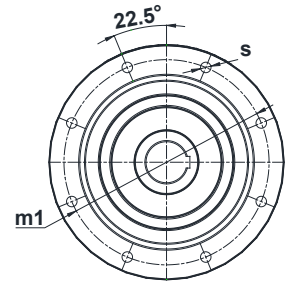

Tip Type Typ	m	m1	m2	h	h1	f	u	s	L	l1	l2	d	d1	e1	t1
D.B 28	250	215	180	96	257	4	16	13,5x4	257	60	60	40	41	43,3	12
D.B 37	250	215	180	96	275,5	4	16	13,5x4	275,5	70	70	40	41	43,3	12
D.B 47	300	265	230	100	309,5	4	20	14x4	309,5	82	82	50	51	53,8	14
D.B 57	350	300	250	124	364,5	5	20	18x4	364,5	96	96	60	61	64,4	18
D.B 67	400	350	300	174	476	5	22	18x4	476	110	110	70	71	79,9	20
D.B 77	450	400	350	194	549,5	5	24	18x8	549,5	135	135	90	91	95,4	25
D.B 87	550	500	450	210	629	5	28	18x8	629	160	160	110	111	116,4	28
D.B 97	660	600	550	227	717	6	28	22x8	722	180	180	120	121	127,4	32

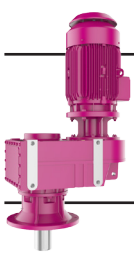

# Ölçü Sayfaları Dimension Pages Abmessungenseiten

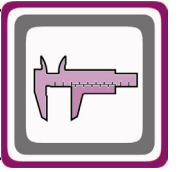

## D SERİSİ DOLU MİLLİ KARIŞTIRICI REDÜKTÖRLERİ ÖLÇÜLERİ D SERIES DRYWELL GEARBOXES WITH SOLID SHAFT DIMENSIONS D SERIEN DRYWELL GETRIEBE MIT VOLLWELLE ABMESSUNGEN

### 1A Dolu Mil Opsiyonu 1A Solid Shaft Option 1A Vollwelle-Ausführung

### Çıkış Flanşı Output Flange Abtriebsflansch

D.28 - D.67

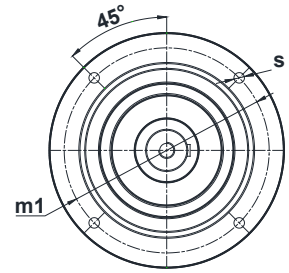

D.77 - D.97

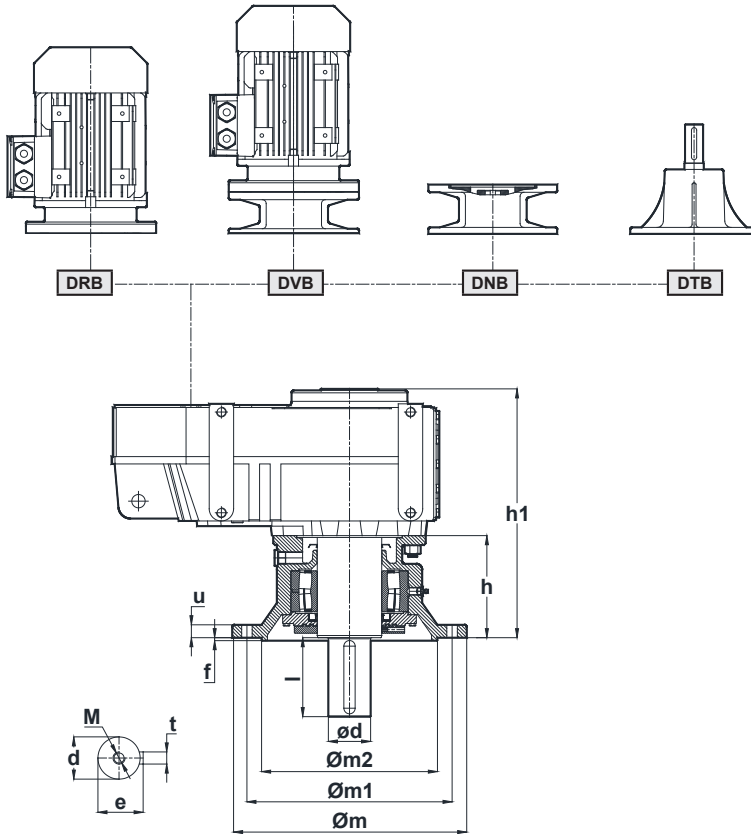
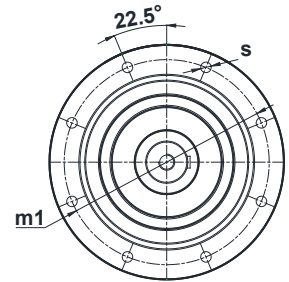

Tip Type Typ	m	m1	m2	h	h1	f	u	s	d	l	e	t	M
D.B 28	250	215	180	96	255	4	16	13,5x4	40	80	43	12	M16
D.B 37	250	215	180	96	272	4	16	13,5x4	40	80	43	12	M16
D.B 47	300	265	230	100	307	4	20	14x4	50	100	53,5	14	M16
D.B 57	350	300	250	124	362	5	20	18x4	60	120	64	18	M20
D.B 67	400	350	300	174	473	5	22	18x4	75	140	79,5	20	M20
D.B 77	450	400	350	194	545	5	24	18x8	90	170	95	25	M24
D.B 87	550	500	450	210	625	5	28	18x8	110	210	116	28	M24
D.B 97	660	600	550	227	711	6	28	22x8	120	210	127	32	M24

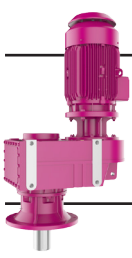

# Ölçü Sayfaları Dimension Pages Abmessungenseiten

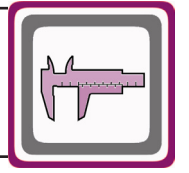

## D SERİSİ SIKMA BİLEZİKLİ KARIŞTIRICI REDÜKTÖRLERİ ÖLÇÜLERİ D SERIES DRYWELL GEARBOXES WITH SHRINK DISK DIMENSIONS D SERIEN DRYWELL GETRIEBE MIT SCHRUMPFSCHEIBE ABMESSUNGEN

### SA Sıkma Bilezik Opsiyonu SA Shrink Disk Option SA Schrumpfscheibe -Ausführung

### Çıkış Flanşı Output Flange Abtriebsflansch

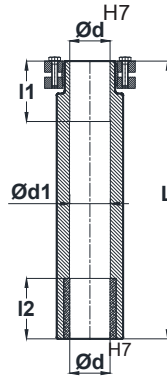
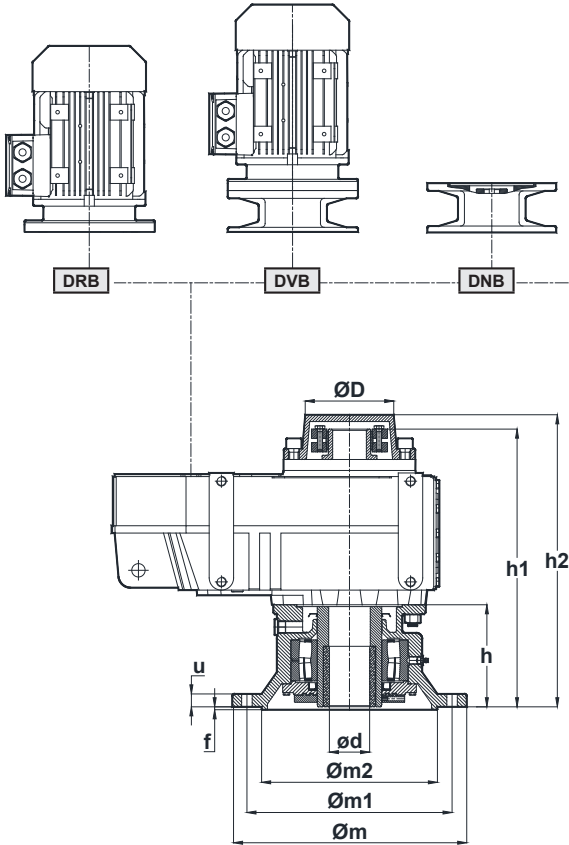

D.28 - D.67

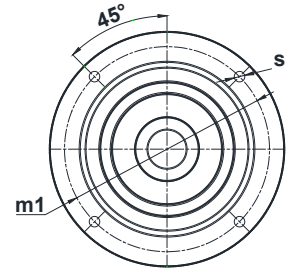

D.77 - D.97

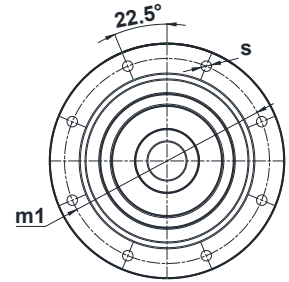

Tip Type Typ	m	m1	m2	h	h1	h2	f	u	s	L	I1	I2	D	d	d1
D.B 28	250	215	180	96	288	304	4	16	13,5x4	288	35	30	104	40	41
D.B 37	250	215	180	96	306.5	325	4	16	13,5x4	306.5	45	50	106	40	41
D.B 47	300	265	230	100	343.5	360	4	20	14x4	343.5	47.5	52.5	120	50	51
D.B 57	350	300	250	124	400.5	423	5	20	18x4	400.5	55	60	159	60	61
D.B 67	400	350	300	174	512	540	5	22	18x4	512	60	65	164	70	71
D.B 77	450	400	350	194	604.5	626	5	24	18x8	604.5	80	80	204	90	91
D.B 87	550	500	450	210	693	720	5	28	18x8	693	85	90	252	110	111
D.B 97	660	600	550	227	787	810	6	28	22x8	787	90	80	288	120	121



# Ölçü Sayfaları Dimension Pages Abmessungsseiten

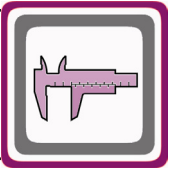

## D SERİSİ OPSİYONEL ÇIKIŞ FLANŞ ÖLÇÜLERİ OPTIONAL OUTPUT FLANGE DIMENSIONS FOR D SERIES AUSWÄHLBARE ABTRIEBSFLANGEDIMENSIONEN FÜR BAUREIHE D

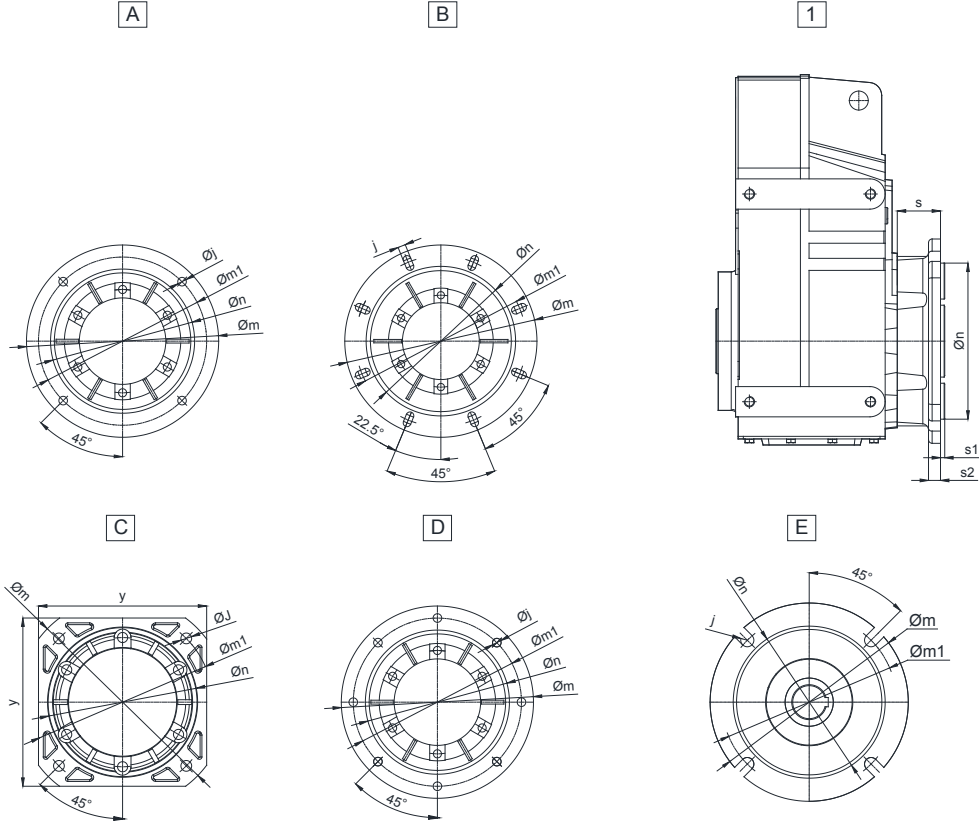

Tip Type Typ	Flanş Kodu Flange Code Flanschkode	Flanş Tipi Flange Type Flanschtyp	Montaj Ölçüleri Mounting Dimensions Montageabmessungen							
			Øm	Øm1	Øn	j	s	s1	s2	y
D073 D173	DX05.5D173-200	E1	200	165	130	14	28	3,5	12	-
D273	DX05.5D273-250	A1	250	215	180	Ø14	39,5	4	15	-
D283 D373	MX05.5K373-250X05	A1	250	215	180	Ø14	86	4	15	-
	MX05.5K373-300	C1	300	265	230	14	46	4	16	240x240
	DX05.5D283-200	A1	200	165	130	12	30	4	19	-
	DX05.5D283-250	A1	250	215	180	Ø14	40	4	15	-
D473	MX05.5K473-250	A1	250	215	180	14	28	4	16	-
	MX05.5K473-350	A1	350	300	250	Ø18	46,5	4	18	-
D573 D673	MX05.5K573X08	C1	350	300	250	Ø18	78	5	18	280x280
	MX05.5K573-300	A1	300	265	230	M12	30	4	20	-
	MX05.5K673-450	B1	450	400	350	18	62	5	22	-
	DX05.5D573-400	D1	400	350	300	Ø18	55	5	20	-
	DX05.5D673-450	D1	450	400	350	Ø18	54,5	5	20	-
D773	MX05.5K773-400	B1	400	350	300	Ø18	77	5	24	-
D873	MX05.5K873-450	B1	450	400	350	Ø18	99	5	26	-
	MX05.5K873-550X01	B1	550	500	450	18	51	5	25	-



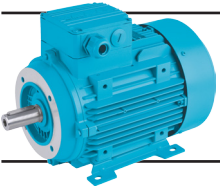

# **Elektrik Motorlarının Performans Deęerleri**

*Electric Motors  
Ratings and Performance*

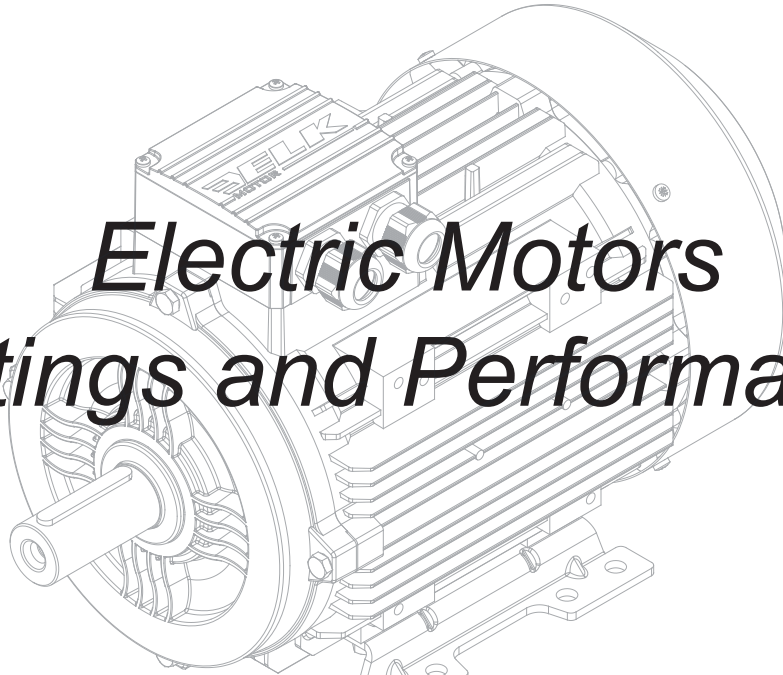

**Elektromotoren  
Leistungsdaten**

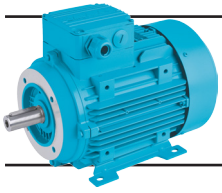

# Elektrik Motorlarının Performans Değerleri

## Electric Motors Ratings and Performance

### Elektromotoren Leistungsdaten



400V 50Hz 3000 d/d / 400V 50Hz 3000 rpm / 400V 50Hz 3000 UpM

IE3

Tip Type Typ	Tam Yük Değerleri Full-load Data Vollastdaten							Kalkış Değerleri Starting Data Startdaten			Devrilme Momenti Breakdown Torque Kippmoment	Atalet Momenti Moment of Inertia Trägheitsmoment	B3 Motor Ağırlığı B3 Motor Weight B3 Motor Gewicht	Ses Seviyesi Noise Level Geräuschpegel
	Güç Power Leistung	Devir Speed Drehzahl	Akım Current Nennstrom	Moment Torque Drehmoment	Güç Faktörü Power Factor Leistungsfaktor	Verim % $\eta$ Efficiency % $\eta$ Wirkungsgrad % $\eta$			Akım Current Nennstrom	Moment Torque Drehmoment				
	kW	d/d rpm UpM	A	Nm	cos $\phi$	4 / 4	3 / 4	1 / 2	$I_A/I_N$	$M_A/M_N$				
											$M_K/M_N$	kgm <sup>2</sup>	kg	dB(A)
3E71M/2B	0,37	2830	0,86	1,25	0,81	76,6	77,0	75,0	6,0	2,8	3,0	0,00037	6,2	53
3E71M/2C	0,55	2830	1,19	1,86	0,84	79,4	80,2	78,8	6,1	2,9	3,3	0,00046	7,2	53
3E80M/2B	0,75	2880	1,59	2,49	0,84	80,7	82,0	81,5	6,7	3,0	3,6	0,00103	9,6	54
3E80M/2C	1,1	2880	2,26	3,64	0,85	82,7	83,0	82,4	6,8	3,1	3,8	0,00124	10,9	54
3E90S/2B	1,5	2900	2,97	4,94	0,86	84,8	85,4	84,2	7,6	3,1	3,9	0,00178	15,6	59
3E90L/2C	2,2	2900	4,25	7,24	0,87	85,9	86,8	86,1	7,2	3,0	3,8	0,00221	17,0	59
3E100L/2C	3	2910	5,58	9,85	0,89	87,1	87,6	86,9	7,9	3,0	4,1	0,00450	23,3	62
3E112M/2C	4	2915	7,28	13,1	0,90	88,1	88,8	88,2	7,5	2,6	3,9	0,00620	29,1	65
3E132S/2B	5,5	2945	9,9	17,83	0,90	89,2	89,0	88,6	8,9	2,9	3,9	0,01730	44,4	67
3E132S/2C	7,5	2945	13,2	24,32	0,91	90,1	90,5	89,7	8,4	2,6	4,0	0,02100	51,5	67
3E160M/2B	11	2950	19,7	35,6	0,88	91,2	91,0	90,5	8,0	2,6	3,9	0,03320	79,7	69
3E160M/2C	15	2950	25,9	48,55	0,91	91,9	92,1	91,6	8,9	3,1	4,2	0,03910	86,0	69
3E160L/2D	18,5	2945	31,7	60	0,91	92,4	92,7	92,3	8,9	3,1	4,2	0,04410	96,7	69
3E180M/2B	22	2957	38,1	71,05	0,90	92,7	92,9	92,0	8,6	2,6	3,9	0,06300	178	70
3E200L/2B	30	2970	52	96,46	0,89	93,6	93,8	93,6	8,9	3,2	3,5	0,16200	245	72
3E200L/2C	37	2970	62,6	119	0,91	93,7	93,8	93,4	9,3	3,2	3,4	0,17500	270	72
3E225M/2C	45	2975	75,6	144,4	0,91	94,3	94,6	94,0	9,8	3,5	3,9	0,25400	335	74
3E250M/2C	55	2970	93,3	176,9	0,90	94,4	94,8	94,5	8,9	3,3	3,4	0,38000	422	75
3E280S/2B	75	2980	127	240,35	0,90	94,7	94,7	94,0	7,5	2,7	3,2	0,79000	560	76
3E280M/2C	90	2985	150	287,94	0,91	95,0	95,1	94,5	7,6	2,7	3,1	0,90000	630	76
3G315S/2	110	2985	186	352	0,90	95,2	95,2	94,0	8,0	2,5	3,0	1,20000	742	76
3G315M/2	132	2985	223	422	0,90	95,4	95,4	94,1	8,0	2,4	3,5	1,40000	812	79
3G315L/2a	160	2985	265	512	0,91	95,6	95,6	94,2	8,0	2,5	3,0	1,50000	912	79

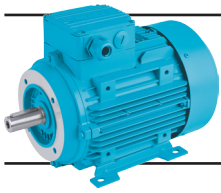

# Elektrik Motorlarının Performans Değerleri

## Electric Motors Ratings and Performance

### Elektromotoren Leistungsdaten



400V 50Hz 1500 d/d / 400V 50Hz 1500 rpm / 400V 50Hz 1500 UpM

IE3

Tip Type Typ	Tam Yük Değerleri Full-load Data Volllastdaten							Kalkış Değerleri Starting Data Startdaten			Devrilme Momenti Breakdown Torque Kippmo- ment	Atalet Momenti Moment of Inertia Trägheits- moment	B3 Motor Ağırlığı B3 Motor Weight B3 Motor Gewicht	Ses Seviyesi Noise Level Geräusch- pegel
	Güç	Devir	Akım	Moment	Güç Faktörü	Verim % $\eta$			Akım	Moment				
	Power	Speed	Current	Torque	Power Factor	Efficiency % $\eta$			Current	Torque				
	Leistung	Drehzahl	Nennstrom	Drehmoment	Leistungsfaktor	Wirkungsgrad % $\eta$			Nennstrom	Drehmoment				
	kW	d/d rpm UpM	A	Nm	cos $\phi$	4 / 4	3 / 4	1 / 2	$I_A/I_N$	$M_A/M_N$	$M_K/M_N$	kgm <sup>2</sup>	kg	dB(A)
3E71M/4C	0,25	1435	0,67	1,66	0,71	76,0	75,4	71,5	5,4	2,2	3,0	0,00082	6,8	45
3E71M/4D	0,37	1435	0,97	2,46	0,70	78,5	78,2	75,0	5,5	2,2	3,1	0,00093	7,5	45
3E80M/4C	0,55	1450	1,34	3,62	0,73	80,8	80,4	77,0	5,9	2,1	3,1	0,00200	10,5	50
3E80M/4D	0,75	1450	1,77	4,94	0,74	82,5	82,3	80,0	6,2	2,5	3,4	0,00227	11,6	50
3E90S/4C	1,1	1450	2,46	7,25	0,76	84,5	84,3	82,0	7,0	2,6	3,6	0,00355	16,3	51
3E90L/4D	1,5	1450	3,3	9,88	0,77	85,3	85,2	83,0	7,2	2,8	3,8	0,00410	18,0	51
3E100L/4C	2,2	1450	4,65	14,49	0,79	86,7	87,2	86,0	7,2	2,8	3,6	0,00780	24,4	53
3E100L/4D	3	1450	6,26	19,76	0,79	87,7	88,0	87,0	7,2	2,8	3,6	0,00890	26,7	53
3E112M/4D	4	1460	8,05	26,16	0,81	88,6	88,4	87,5	7,4	2,8	3,8	0,01430	33,9	58
3E132S/4C	5,5	1460	10,65	36	0,83	89,6	90,2	90,0	7,4	2,8	3,4	0,03060	53,4	61
3E132M/4D	7,5	1465	14,4	48,9	0,83	90,4	90,4	89,4	7,9	3,0	3,8	0,03420	59,5	61
3E160M/4C	11	1470	21	71,46	0,83	91,5	92,1	91,7	7,6	2,8	3,3	0,07010	89,2	63
3E160L/4D	15	1470	28,7	97,45	0,82	92,1	92,4	91,9	7,8	2,8	3,6	0,08600	97,5	63
3E180M/4C	18,5	1475	35	119,8	0,82	92,6	93,2	92,9	7,7	3,0	3,3	0,12900	173	64
3E180L/4D	22	1470	41,4	142,92	0,82	93,0	93,7	93,7	8,0	3,0	3,4	0,14700	187	64
3E200L/4D	30	1475	54,5	194,2	0,85	93,6	94,1	94,0	8,0	3,0	3,4	0,28400	258	65
3E225S/4C	37	1478	65,7	239	0,87	93,9	94,5	94,5	8,3	3,2	3,3	0,38200	320	66
3E225M/4D	45	1477	80	290,9	0,86	94,2	94,7	94,7	8,6	3,3	3,2	0,44100	352	67
3E250M/4D	55	1482	95,3	354,4	0,88	94,6	95,1	95,2	8,7	3,3	3,2	0,73400	470	68
3E280S/4C	75	1485	129,5	482,3	0,86	95,0	95,3	95,1	7,9	3,0	3,2	1,40000	646	69
3E280M/4D	90	1485	155,5	578,8	0,86	95,2	95,7	95,7	7,9	3,1	3,2	1,50000	670	70
3G315S/4	110	1487	194	706	0,86	95,4	95,2	95,0	7,4	2,4	3,0	2,5000	861	74
3G315M/4a	132	1488	226	847	0,88	95,6	95,4	95,3	7,4	2,4	3,0	2,8000	882	74
3G315L/4a	160	1488	275	1027	0,88	95,8	95,6	95,6	6,9	2,2	2,9	3,0000	930	74

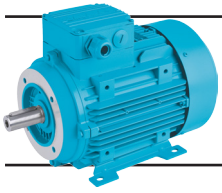

# Elektrik Motorlarının Performans Değerleri

## Electric Motors Ratings and Performance

### Elektromotoren Leistungsdaten



400V 50Hz 1000 d/d / 400V 50Hz 1000 rpm / 400V 50Hz 1000 UpM

IE3

Tip Type Typ	Tam Yük Değerleri Full-load Data Volllastdaten								Kalkış Değerleri Starting Data Startdaten		Devrilme Momenti Breakdown Torque Kippmoment	Atalet Momenti Moment of Inertia Trägheitsmoment	B3 Motor Ağırlığı B3 Motor Gewicht	Ses Seviyesi Noise Level Geräuschpegel
	Güç Power Leistung	Devir Speed Drehzahl	Akım Current Nennstrom	Moment Torque Drehmoment	Güç Faktörü Power Factor Leistungsfaktor	Verim % $\eta$ Efficiency % $\eta$ Wirkungsgrad % $\eta$			Akım Current Nennstrom	Moment Torque Drehmoment				
	kW	d/d rpm UpM	A	Nm	cos $\phi$	4 / 4	3 / 4	1 / 2	$I_A/I_N$	$M_A/M_N$				
											$M_K/M_N$	kgm <sup>2</sup>	kg	dB(A)
3E71M/6C	0,18	930	0,55	1,85	0,69	68,0	67,4	62,6	3,6	2,0	2,4	0,00096	6,7	41
3E71M/6D	0,25	930	0,77	2,57	0,67	70,0	69,7	66,0	3,6	2,2	2,5	0,00116	7,5	41
3E80M/6B	0,37	930	1,03	3,8	0,70	74,0	73,8	70,0	4,4	2,1	2,6	0,00202	9,8	43
3E80M/6C	0,55	935	1,47	5,62	0,70	77,2	77,3	74,4	4,3	2,2	2,7	0,00228	10,6	43
3E90S/6B	0,75	945	1,96	7,58	0,70	78,9	79,2	77,6	4,7	2,2	2,7	0,00354	14,6	46
3E90L/6C	1,1	940	2,75	11,2	0,71	81,0	80,8	79,4	5,0	2,2	2,7	0,00428	17,0	46
3E100L/6B	1,5	955	3,5	15	0,75	82,5	82,7	81,4	5,3	2,1	2,8	0,00820	22,5	50
3E112M/6B	2,2	960	4,95	21,9	0,76	84,3	84,5	83,5	5,5	2,2	3,0	0,01320	27,2	56
3E132S/6B	3	970	6,55	29,4	0,77	85,6	85,5	84,5	6,2	2,1	3,0	0,03050	46,5	58
3E132M/6C	4	970	8,52	39,4	0,78	86,8	87,0	85,5	6,2	2,2	3,0	0,03500	51,0	58
3E132M/6D	5,5	965	11,55	54,4	0,78	88,0	88,9	88,5	6,2	2,2	3,0	0,03940	56,0	58
3E160M/6D	7,5	972	15,55	73,8	0,78	89,1	89,4	88,4	6,3	2,6	3,0	0,07870	96,0	61
3E160L/6E	11	972	22,9	108,07	0,77	90,3	90,9	90,5	6,6	2,9	3,3	0,08580	104	62
3E180L/6E	15	975	30,80	147,92	0,77	91,2	91,6	91,0	6,7	2,9	3,1	0,15300	187	63
3E200L/6C	18,5	977	36,4	180,8	0,80	91,7	91,8	91,8	6,1	2,6	2,6	0,36100	225	64
3E200L/6D	22	978	42,5	214,8	0,81	92,2	92,9	93,0	6,2	2,6	2,7	0,39400	245	64
3E225M/6C	30	985	57,6	290,8	0,81	92,9	92,9	92,6	6,6	2,6	2,7	0,60000	326	65
3E250M/6C	37	988	68,8	357,6	0,83	93,4	93,6	93,5	6,8	2,7	2,68	0,82000	432	65
3E280S/6B	45	989	82,5	434,5	0,84	93,7	93,9	93,2	6,8	2,9	2,8	1,45000	540	65
3E280M/6C	55	989	100,4	531	0,84	94,1	94,4	93,5	6,9	2,9	2,9	1,6500	575	65
3G315S/6	75	992	140	722	0,82	94,6	94,6	94,4	7,2	2,7	3,0	2,9000	805	72
3G315M/6a	90	992	166	866	0,82	94,9	94,9	94,5	7,2	2,7	3,0	3,5000	860	72
3G315M/6b	110	992	198	1059	0,84	95,1	95,1	94,9	7,2	2,7	3,0	4,2000	980	72
3G315L/6	132	992	235	1271	0,85	95,4	95,4	95,2	7,2	2,7	3,0	4,3000	1150	72
3G355M/6a	160	993	197	1539	0,82	95,6	95,6	95,0	7,0	2,4	3,2	6,8000	1185	72

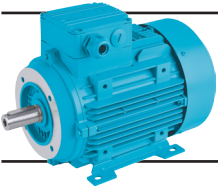

# Elektrik Motorlarının Performans Değerleri

## Electric Motors Ratings and Performance

### Elektromotoren Leistungsdaten



400V 50Hz 3000 d/d / 400V 50Hz 3000 rpm / 400V 50Hz 3000 UpM

IE2

Tip Type Typ	Tam Yük Değerleri Full-load Data Vollastdaten							Kalkış Değerleri Starting Data Startdaten			Devrilme Momenti Breakdown Torque Kippmo- ment	Atalet Momenti Moment of Inertia Trägheits- moment	B3 Motor Ağırlığı B3 Motor Weight B3 Motor Gewicht	Ses Seviyesi Noise Level Geräusch- pegel
	Güç	Devir	Akım	Moment	Güç Faktörü	Verim % $\eta$			Akım	Moment				
	Power	Speed	Current	Torque	Power Factor	Efficiency % $\eta$			Current	Torque				
	Leistung	Drehzahl	Nennstrom	Drehmoment	Leistungsfaktor	Wirkungsgrad % $\eta$			Nennstrom	Drehmoment				
	kW	d/d rpm UpM	A	Nm	cos $\phi$	4 / 4	3 / 4	1 / 2	$I_A/I_N$	$M_A/M_N$	$M_K/M_N$	kgm <sup>2</sup>	kg	dB(A)
G56/2b*	0,12	2800	0,35	0,41	0,74	64,5	64,1	56,9	4,2	2,5	2,8	0,00012	2,8	42
G63/2a*	0,18	2820	0,5	0,61	0,73	64,4	64,2	57,7	4,6	2,9	2,9	0,00011	3,6	52
G63/2b*	0,25	2840	0,67	0,84	0,63	67,3	67,1	60,9	4,5	2,5	2,9	0,00013	4,0	52
2E71M/2A	0,37	2790	0,9	1,26	0,80	74,2	74,5	72,5	5,0	2,5	2,8	0,00031	5,5	54
2E71M/2B	0,55	2790	1,27	1,88	0,82	75,8	77,0	76,0	5,0	2,8	2,9	0,00037	6,3	54

\* : IE1 Verisi / IE1 Data / IE1 Daten

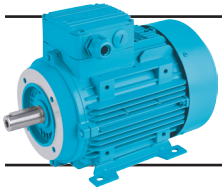

# Elektrik Motorlarının Performans Değerleri

## Electric Motors Ratings and Performance

### Elektromotoren Leistungsdaten



400V 50Hz 1500 d/d / 400V 50Hz 1500 rpm / 400V 50Hz 1500 UpM

IE2

Tip Type Typ	Tam Yük Değerleri Full-load Data Vollastdaten								Kalkış Değerleri Starting Data Startdaten		Devrilme Momenti Breakdown Torque	Atalet Momenti Moment of Inertia	B3 Motor Ağırlığı B3 Motor Weight	Ses Seviyesi Noise Level
	Güç Power Leistung	Devir Speed Drehzahl	Akım Current Nennstrom	Moment Torque Drehmoment	Güç Faktörü Power Factor Leistungsfaktor	Verim % $\eta$ Efficiency % $\eta$ Wirkungsgrad % $\eta$			Akım Current Nennstrom	Moment Torque Drehmoment	Kippmo- ment	Trägheits- moment	B3 Motor Gewicht	Geräusch- pegel
	kW	d/d rpm UpM	A	Nm	cos $\phi$	4 / 4	3 / 4	1 / 2	$I_A/I_N$	$M_A/M_N$	$M_K/M_N$	kgm <sup>2</sup>	kg	dB(A)
G63/4a*	0,12	1365	0,41	0,84	0,74	57,1	57,1	53,3	3,1	2,0	2,2	0,00017	3,4	43
G63/4b*	0,18	1340	0,6	1,28	0,73	59,7	59,7	55,8	2,9	2,0	2,0	0,00021	3,9	43
2E71M/4B	0,25	1425	0,71	1,68	0,69	74,0	73,5	70,5	4,4	2,0	3,0	0,00067	5,9	46
2E71M/4C	0,37	1425	1,0	2,47	0,70	76,1	75,5	71,5	4,6	2,0	3,0	0,00082	6,7	46
2E80M/4B	0,55	1440	1,45	3,65	0,71	77,1	76,7	75,0	5,2	2,0	3,0	0,00175	9,7	50

\* : IE1 Verisi / IE1 Data / IE1 Daten

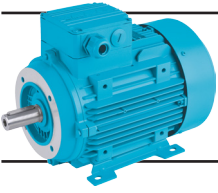

# Elektrik Motorlarının Performans Değerleri

## Electric Motors Ratings and Performance

### Elektromotoren Leistungsdaten



400V 50Hz 1000 d/d / 400V 50Hz 1000 rpm / 400V 50Hz 1000 UpM

IE2

Tip Type Typ	Tam Yük Değerleri Full-load Data Vollastdaten							Kalkış Değerleri Starting Data Startdaten			Devrilme Momenti Breakdown Torque Kippmo- ment	Atalet Momenti Moment of Inertia Trägheits- moment	B3 Motor Ağırlığı B3 Motor Weight B3 Motor Gewicht	Ses Seviyesi Noise Level Geräusch- pegel
	Güç	Devir	Akım	Moment	Güç Faktörü	Verim % $\eta$			Akım	Moment				
	Power	Speed	Current	Torque	Power Factor	Efficiency % $\eta$			Current	Torque				
	Leistung	Drehzahl	Nennstrom	Drehmoment	Leistungsfaktor	Wirkungsgrad % $\eta$			Nennstrom	Drehmoment				
kW	d/d rpm UpM	A	Nm	cos $\phi$	4 / 4	3 / 4	1 / 2	$I_A/I_N$	$M_A/M_N$	$M_K/M_N$	kgm <sup>2</sup>	kg	dB(A)	
2E71M/6B	0,18	920	0,6	1,87	0,67	64,5	63,0	57,0	3,2	1,9	2,3	0,00076	5,9	42
2E71M/6C	0,25	920	0,78	2,59	0,69	66,5	66,0	61,0	3,3	1,9	2,3	0,00096	6,6	42
2E80M/6A	0,37	925	1,08	3,82	0,69	71,4	71,5	70,0	4,0	2,0	2,6	0,00176	9,1	45
2E80M/6B	0,55	932	1,5	5,64	0,72	73,5	74,0	71,0	4,2	2,1	2,6	0,00202	9,9	45

